

CI02 Series 2.00mm(.079") Board In Connectors

- Low profile Housing
- Mate with CI02 Crimp board Terminal
- Insulator: Nylon 66 UL 94V-0, Color Nature
- Terminal: Tin plated Copper alloy

RoHS Compliant  

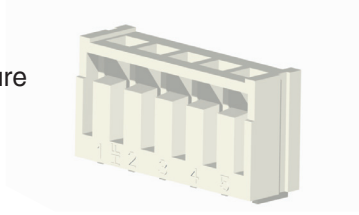

Circuits	Dimension	
	A	B
2	2.0(.079)	5.2(.205)
3	4.0(.157)	7.2(.283)
4	6.0(.236)	9.2(.362)
5	8.0(.315)	11.2(.441)
6	10.0(.394)	13.2(.520)
7	12.0(.472)	15.2(.598)
8	14.0(.551)	17.2(.677)
9	16.0(.630)	19.2(.756)
10	18.0(.709)	21.2(.835)
11	20.0(.787)	23.2(.913)
12	22.0(.866)	25.2(.992)
13	24.0(.945)	27.2(1.071)
14	26.0(1.024)	29.2(1.150)
15	28.0(1.102)	31.2(1.228)
16	30.0(1.181)	33.2(1.307)
17	32.0(1.260)	35.2(1.386)
18	34.0(1.339)	37.2(1.465)
19	36.0(1.417)	39.2(1.543)
20	38.0(1.496)	41.2(1.622)

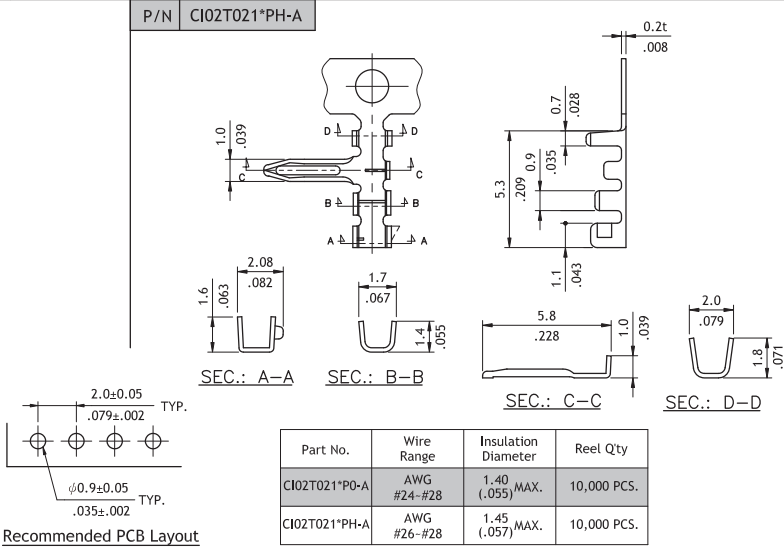
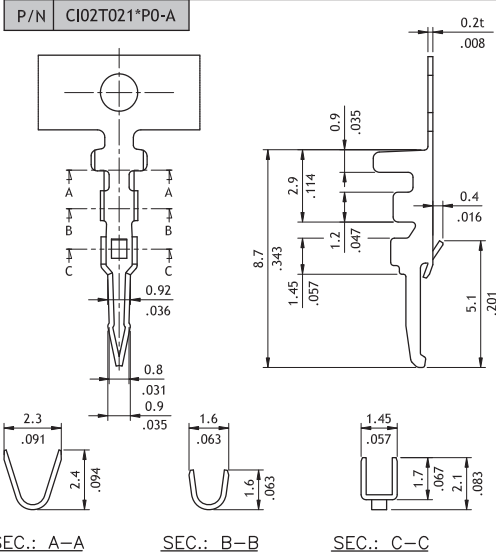
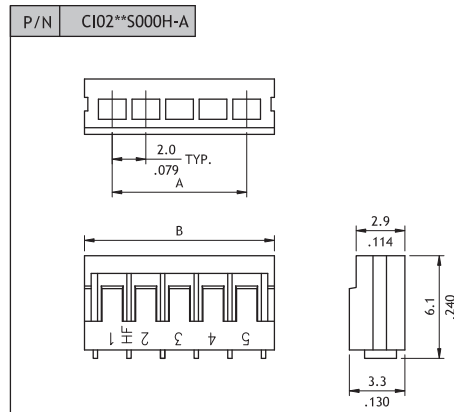
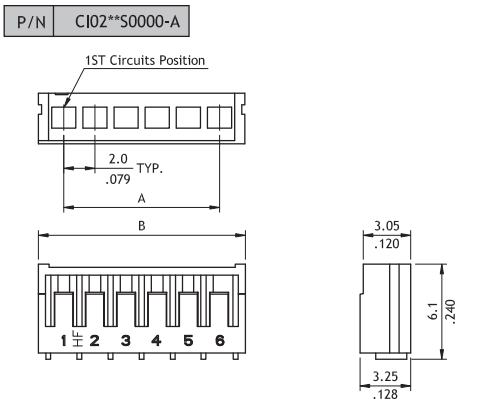

Ordering Code

① ② ③ ④  
**C I 0 2 2 0 S 0 0 0 0 - A**

- ① Series No.
- ② No. of Circuits: 02 to 20
- ③ S = Housing
- ④ Other Options:  
 0000 - A = For Straight Terminal  
 000H - A = For Right Angle Terminal  
 \*Special options consult manufacturer

① ② ③ ④ ⑤  
**C I 0 2 T 0 2 1 P P 0 - A**

- ① Series No.
- ② Type: T02 = AWG #24 ~ #28 (Straight)  
 T02 = AWG #26 ~ #28 (Right Angle)
- ③ Plating Code: 1 = Tin over Nickel plated
- ④ Material: P = Phosphor Bronze ; B = Brass
- ⑤ Terminal Style: P0 - A = Straight  
 PH - A = Right Angle