

CU02 Series USB2.0 Type-B Receptacle Connectors

- ⊙ 4-position shielded receptacle connector
- ⊙ High durability and long cycle life
- ⊙ Designed to meet the USB 2.0 specifications
- ⊙ USB 2.0 Approved Test ID: 60000738

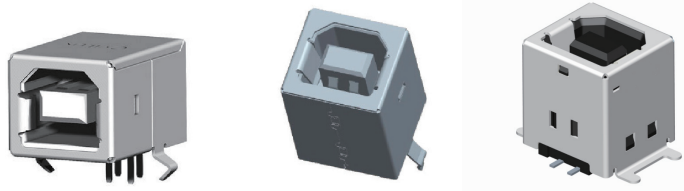

RoHS Compliant



NEW

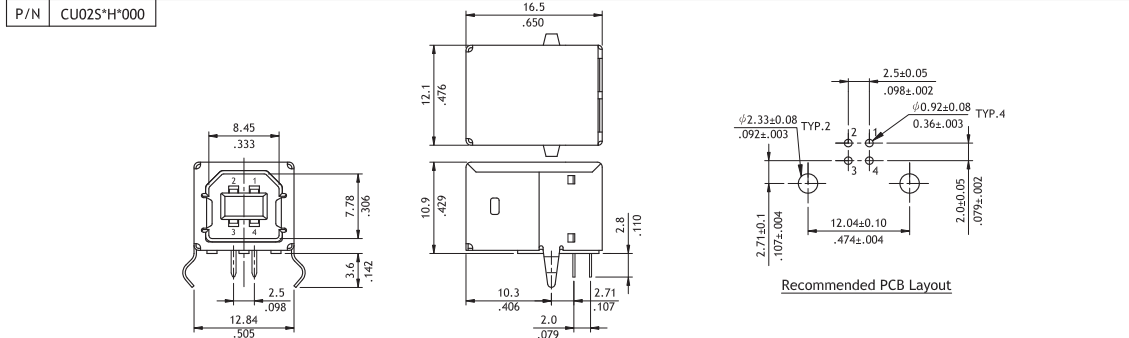
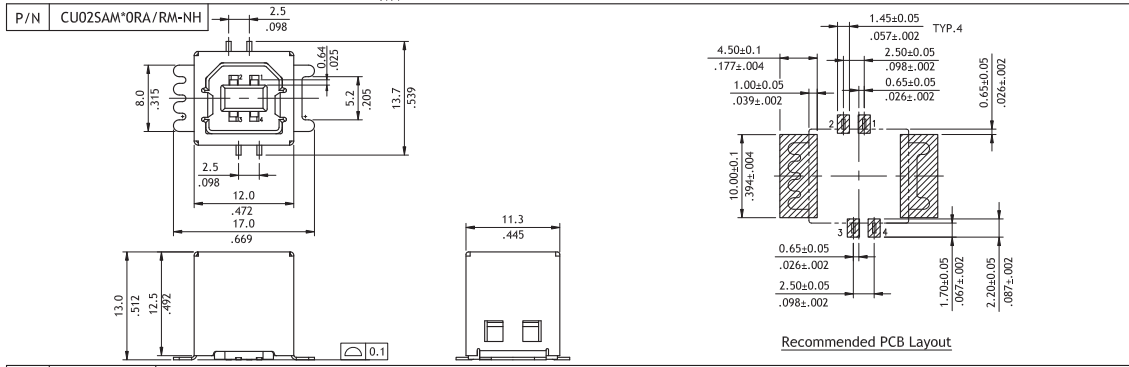
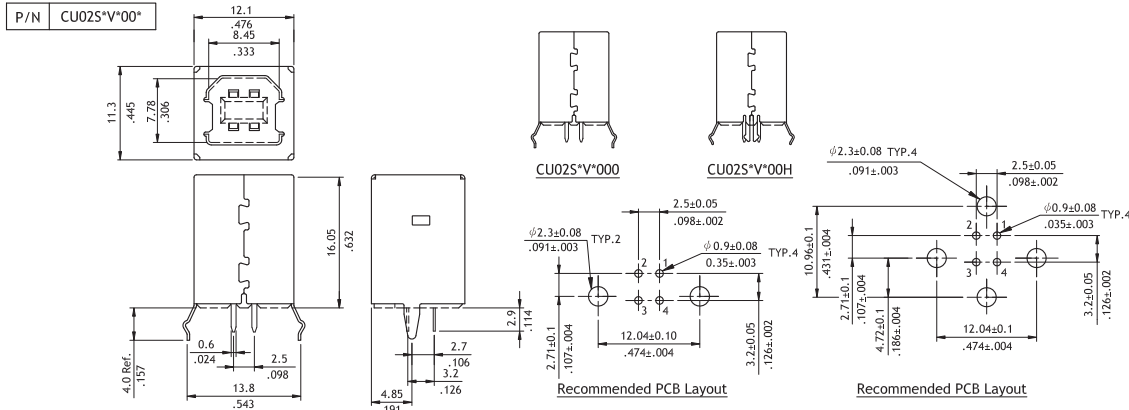

Ordering Code

① ② ③ ④ ⑤ ⑥ ⑦
CU02 S A H 0 0 00

- ① Series No.
- ② S = Socket
- ③ Plating Option:
A = Selective Gold flash plated over Nickel
- ④ Tail Type: V = Straight DIP Type
H = Right Angle DIP Type
M = SMT Type
- ⑤ Insulator Color: 1 = Black
0 = White
- ⑥ 0 = Standard
A = Standard (only for Straight DIP Type)
- ⑦ Other Options: 00 = Standard