

# 2025

Wire Connection Connector | Cable

# General Catalogue

CONNECT THE WORLD CONSERVE THE EARTH

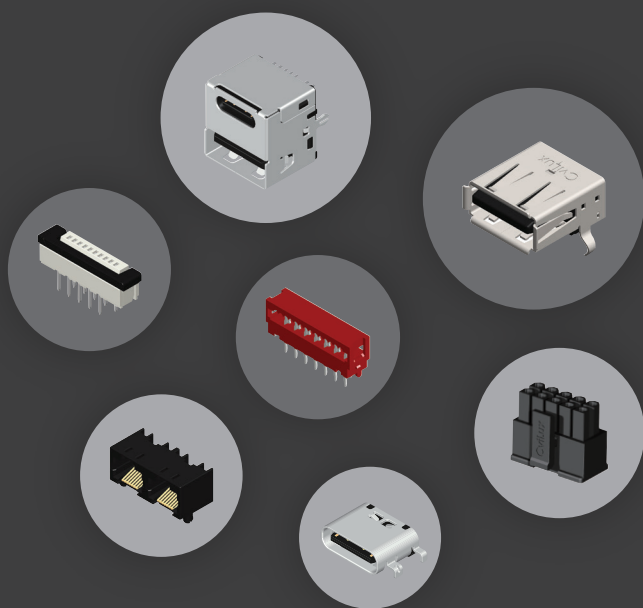

- Laptop Industry
- Networking
- Industrial Electronics
- Handheld Consumer Electronics
- Optoelectronics
- Automotive Electronics
- New Energy Industry
- Smart Home

## TERMS & CONDITIONS

### Sample Request

Samples will be dispatched out by freight collected courier against prices approved by customers.

### Tape & Reel Request

T/R available, please consult manufacturer for details.

### Quotation Validity

Quoted prices are based on current selling prices and will be valid within 6 months from issued date. CviLux reserves the right to adjust quoted prices any time in response to International raw material costs or simply error correction on typing.

### Export Payment Terms

Standard term is T/T in advance. Payment term extension application to be approved by CviLux individually.

### Minimum Package Quantity

Customer order quantity should meet our minimum package quantity for purpose of inventory control and speeding up for delivery.

### Minimum Order Quantity

To smooth production process, please place orders to meet our MOQ based on different products.

### Delivery Term

**(A)** Air shipment amount over USD 5000/ EURO 4500  
F.C.A. Taiwan/H.K./ Shanghai.

**(B)** Air shipment amount less than USD 5000 / EURO 4500:  
F.C.A. Taiwan/H.K./ Shanghai + handling charge USD 350/  
EURO 310 or EXW without handling charge.

**(C)** Sea shipment amount over USD 12000/ EURO 11000:  
F.O.B. Taiwan/H.K./ Shanghai.

**(D)** Sea shipment amount less than USD 12000/ EURO 11000:  
F.O.B. Taiwan/H.K./Shanghai + handling charge USD 350/  
EURO 310 or EXW without handling charge. CviLux reserves the right to adjust handling charge to reflect actual transportation cost and exchange rate if any necessary.

### Time of Delivery

All delivery dates quoted are estimated, are not guaranteed and do not form a term of contract, while every endeavor will be made to comply with these dates, CviLux shall have no liability for any delay in dispatch or delivery.

### Placing Orders

Please place a formal order by fax, e-mail. Verbal Phone orders will not be accepted or entered into our system. place a formal order by fax, e-mail. Verbal phone orders will not be accepted or entered into our system.

### Orders Cancellation and Changes

Customer's orders' cancellation or changes should be informed in 3 days after orders placing. Any unrecoverable manufacturing cost raised by the cancellation and changes will be charged to the customers.

### Shipping

Special shipping instruction will be followed whenever possible. If no special demand of shipping, we will deliver the shipment to you with the "best way."

### Constant Product Improvement

The products supplied may not be agreed in all details with description and illustrations. Product specifications are subject to constant improvement.

### Guarantee

All "non-customized" parts from CviLux Corporation are unconditionally guaranteed for 30 days from the date of shipment.

### Warranty

CviLux Corporation warrants the materials and workmanship of its products for 80 days from the date of shipment.

### Returned Goods

Any defects or errors for which we are responsible will be promptly rectified. Approval for return of goods must be requested by CviLux. All products returned must have been purchased from CviLux Corporation within 6 months from the date of invoice, and must be packed and shipped in clean and re-saleable condition. Credit for returned goods shall only be allowed by receiving CviLux official credit notes acer above requirements have been met

### Force Majeure

CviLux shall have no liability in respect of failure to deliver or per form or delay in delivering or performing any obligations to the customer, due to any cause of whatsoever nature outside of the reasonable control of the seller including but not limited to causes arising from acts or omissions of the customer.

### Export Control Regulations

Some or All of the goods supplied by CviLux may be subject to export control regulations. Such goods may not be exported by the customer without prior approval of the relevant authorities. It is the responsibility of the customer to obtain such approval. Under no circumstances shall the seller be liable for any loss or damages incurred by the customer as a result of customer's contravention of any export control regulations.

# Smart Home



## Wire to Board & Cable Assembly



## Power Connectors

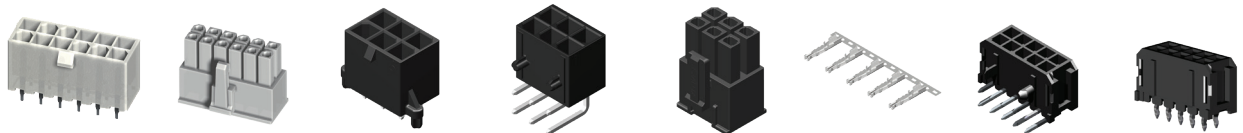

## Pin Headers

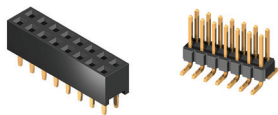

## FFC/ FPC Connectors



## RF Connectors

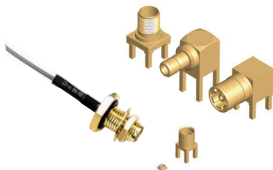

## D-SUB Connectors



## FFC



## USB Type C Connectors & Cable

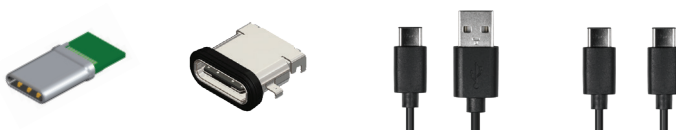

# Networking



## Wire to Board & Cable Assembly



## Pin Headers

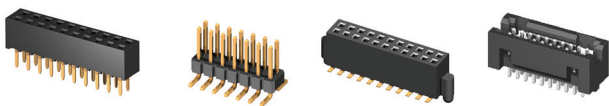

## FFC/ FPC Connectors & FFC

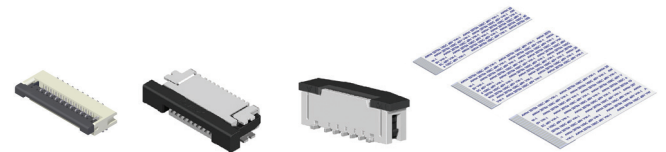

## RF Connectors

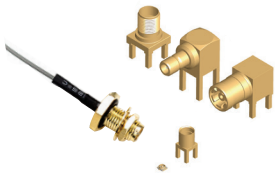

## D-SUB & Combo D-SUB



## Telephone Jacks

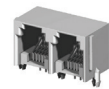

## USB Type C Connectors & Cable



## Mini PCI-E

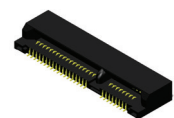



## Wire to Board Connectors & Harness Cable

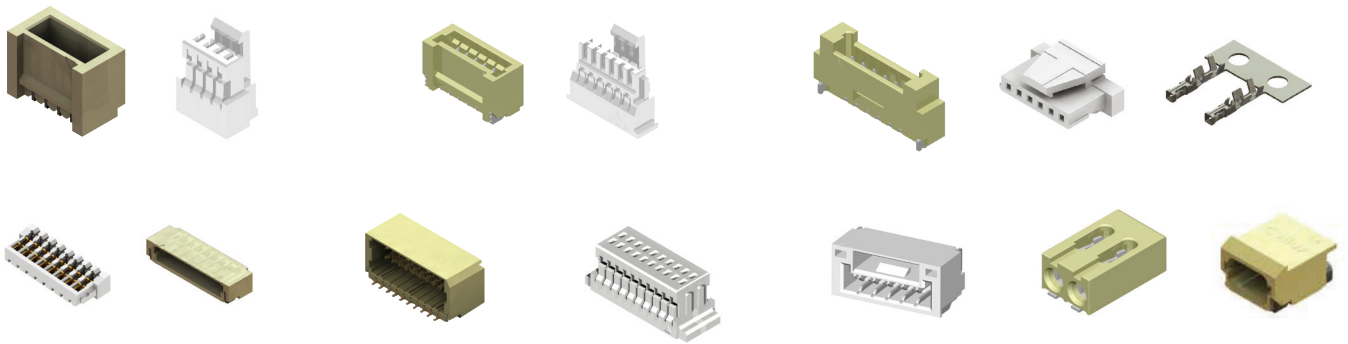

## FFC/FPC Connectors

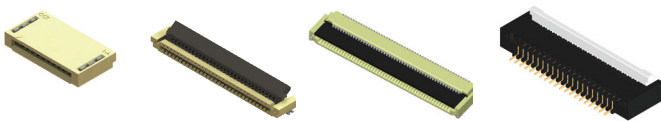

## Power Connectors



## FFC & LVDS FFC

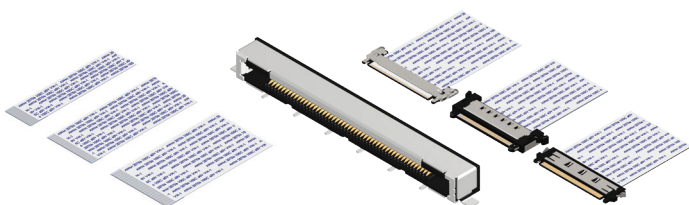

## USB Type C Connectors & Cable



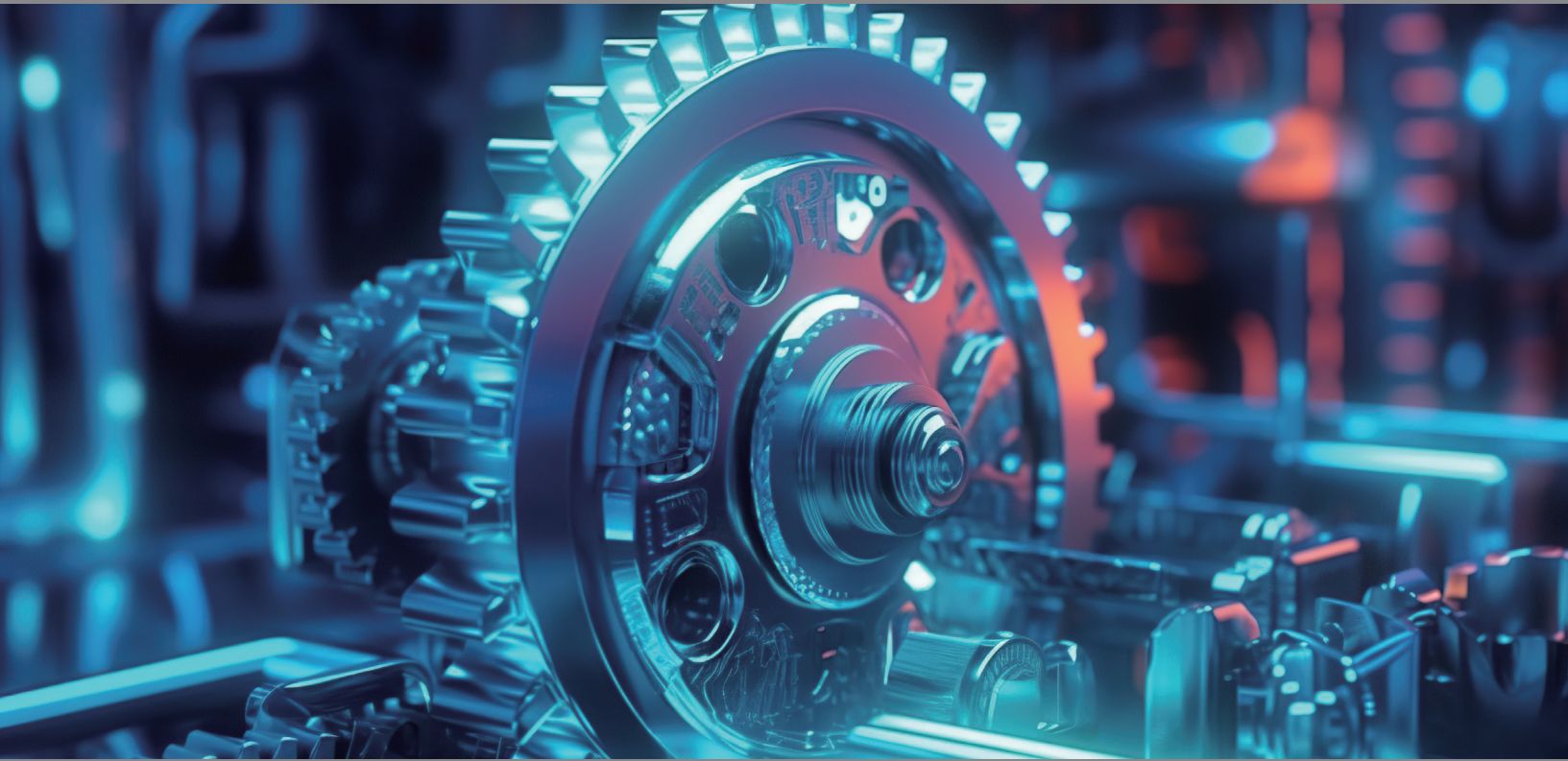

## IDC Connectors & Cable

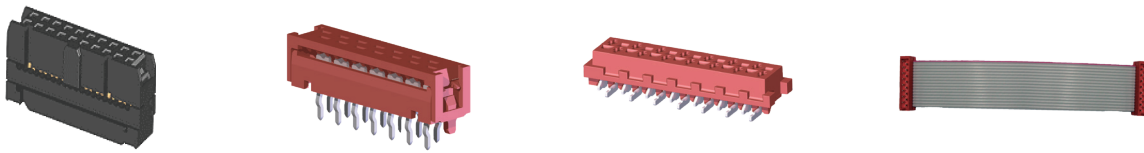

## FFC/FPC Connectors & FFC

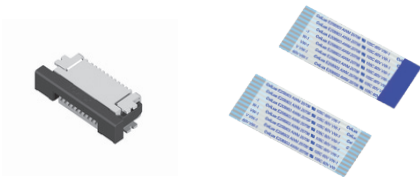

## Power Connectors



## Pin Headers

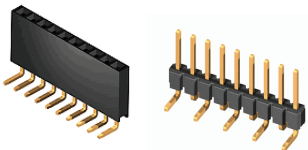

## BTB Connectors

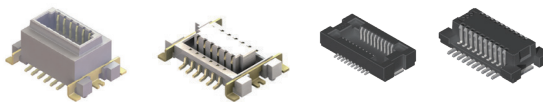

## D-SUB

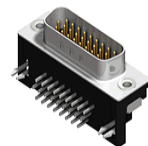

## USB Type C Connectors & Cable

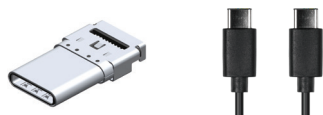

## USB



## IC socket

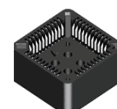

## Jumper



# Laptop Industry

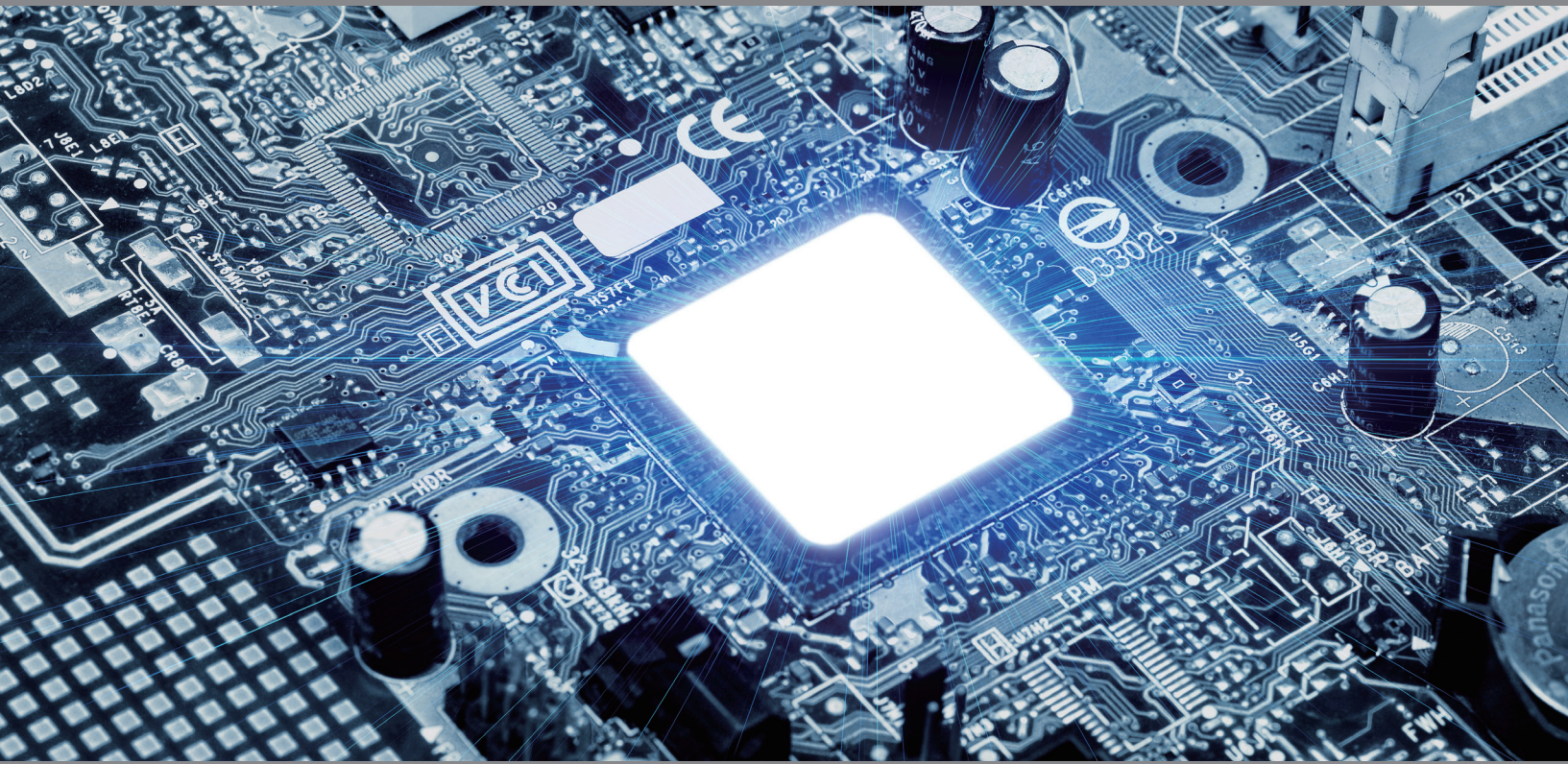

## Wire to Board Connectors

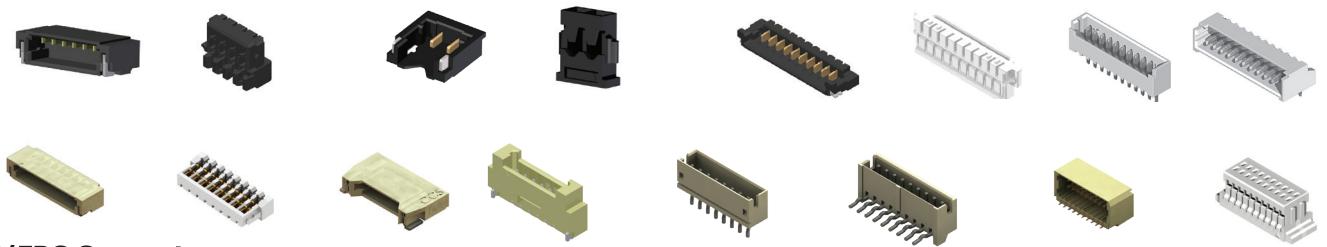

## FFC/FPC Connectors

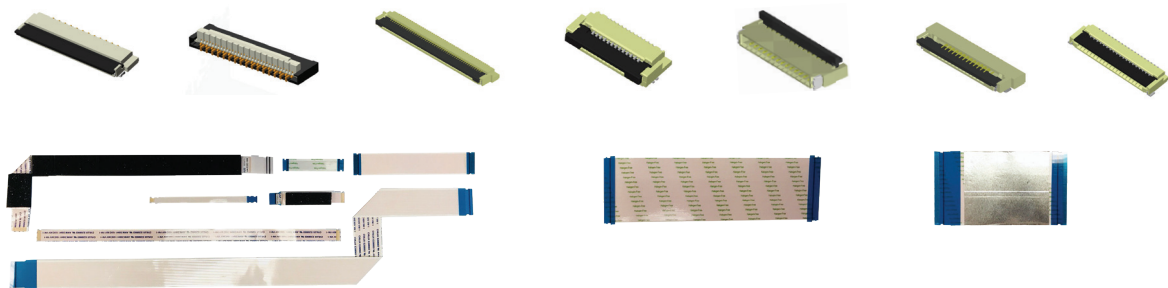

## BTB Connectors

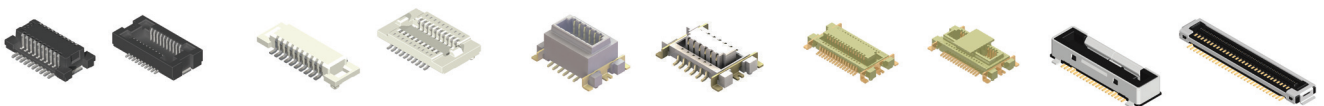

## LVDS Connectors

## USB Type C Connectors



## I/O Connectors



# New Energy Industry



## Wire to Board Connectors

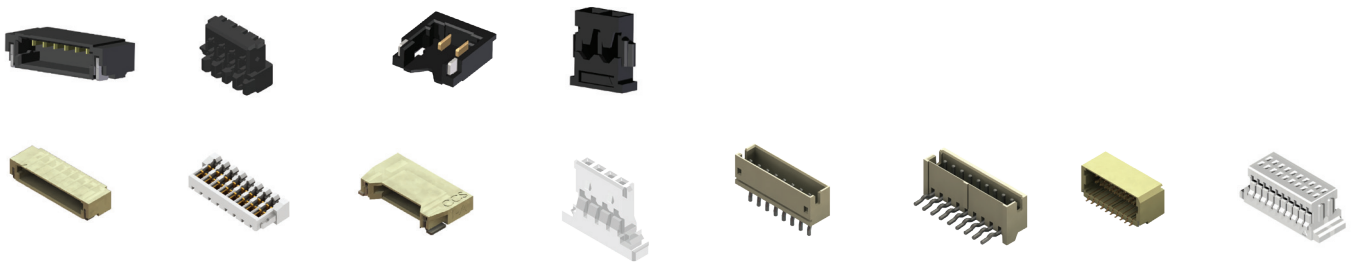

## FFC/FPC Connectors & FFC

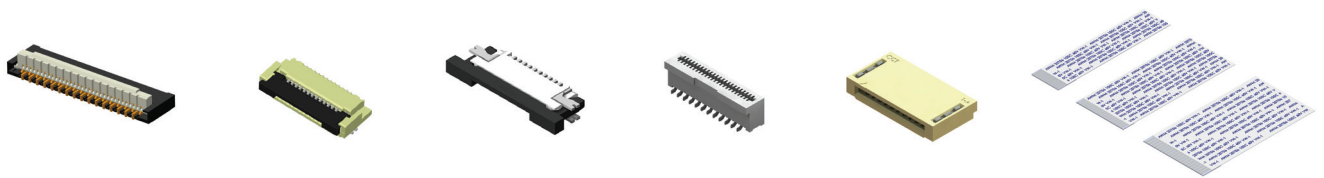

## BTB Connectors

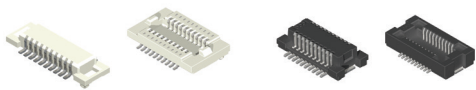

## I/O Connectors



## USB Type C Connectors



## USB Type C Cable



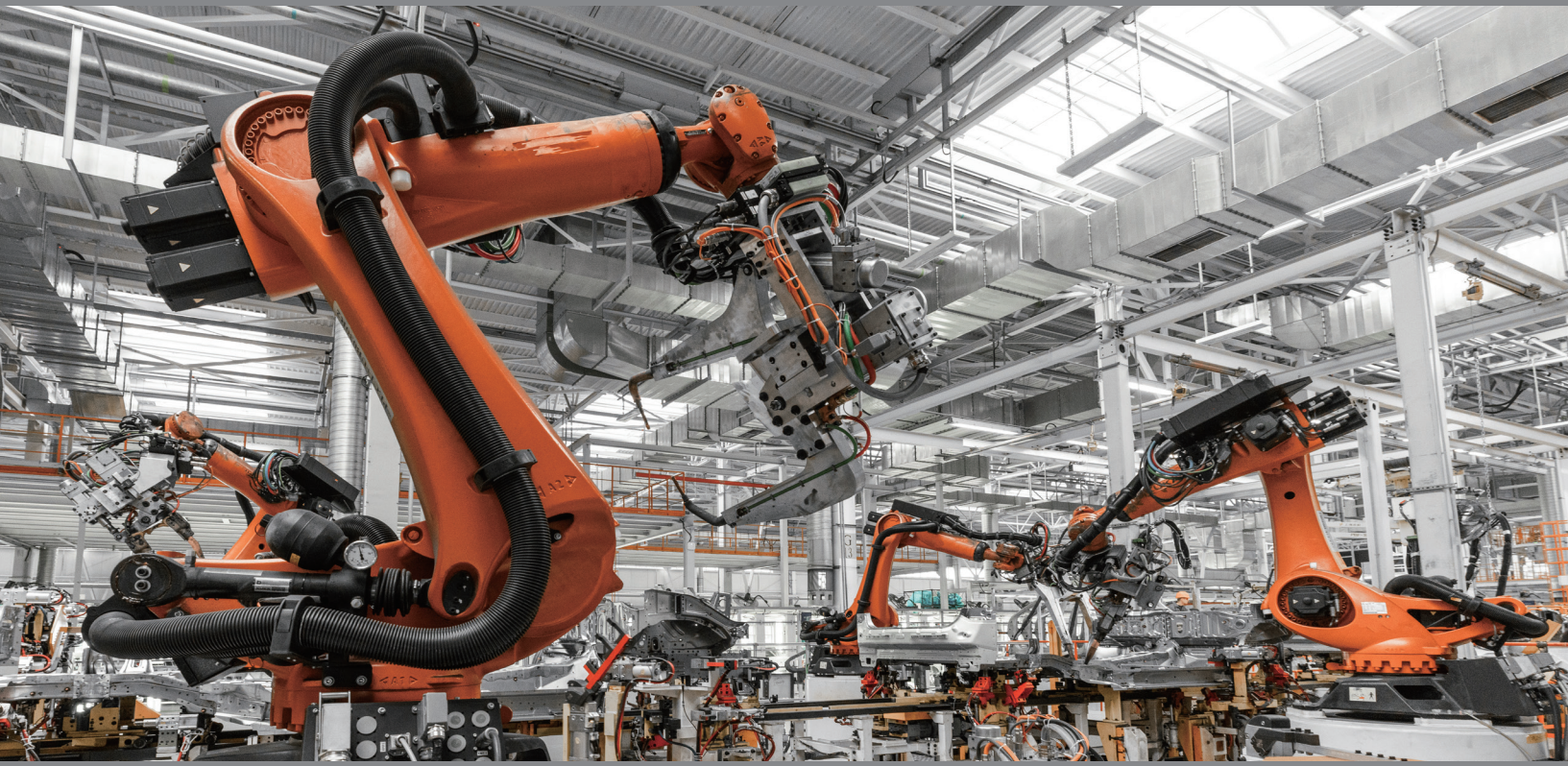

## Wire to Board Connectors

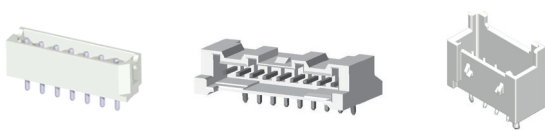

## Pin Headers

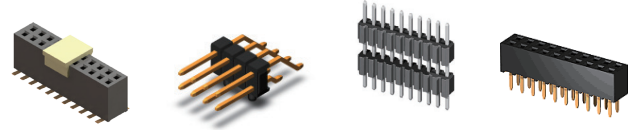

## FFC/FPC/FFCA Connectors

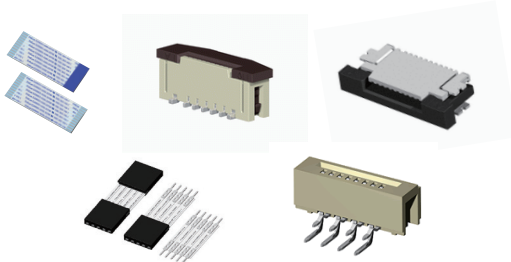

## Power Connectors

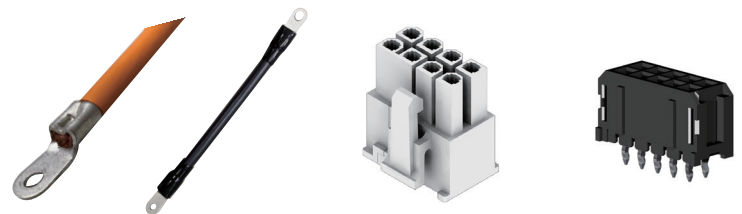

## IDC Connector



## I/O Connectors

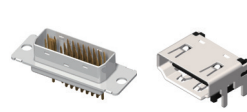

## RF Connectors

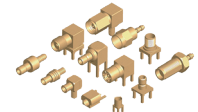

## USB Type C Connectors



## Water Proof Connector & Cable



# Handheld Consumer Electronics



## Board to Board

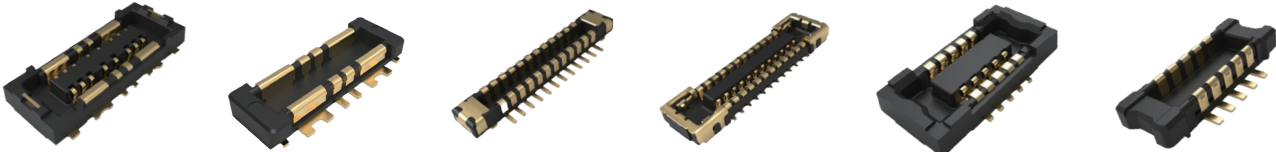

## FPC Connectors

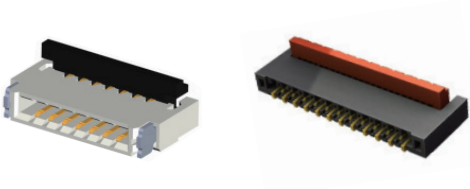

## RF Connector

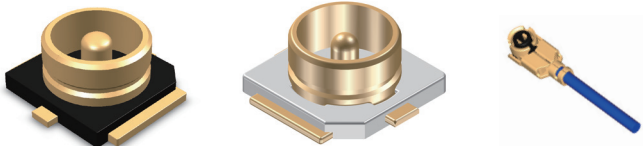

## Wire to Board Connectors

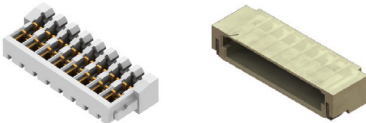

# PRODUCT CATEGORY

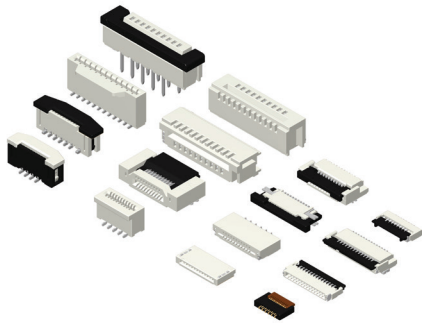

**FFC / FPC Connectors**



**FFC and LVDS Cables**

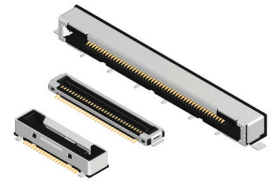

**LVDS Connectors**

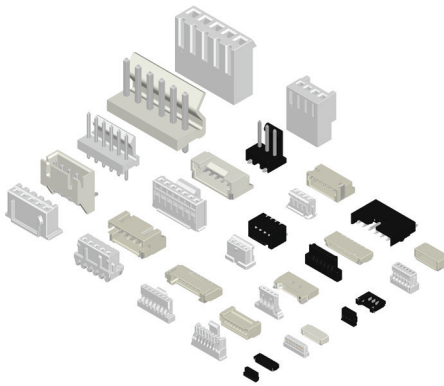

**Wire to Board Connectors**

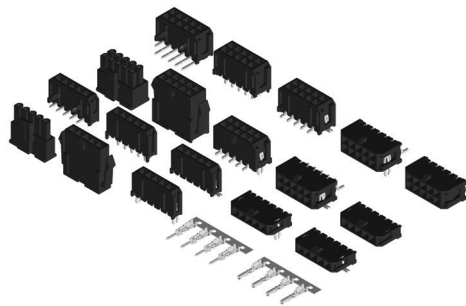

**Power Connectors**

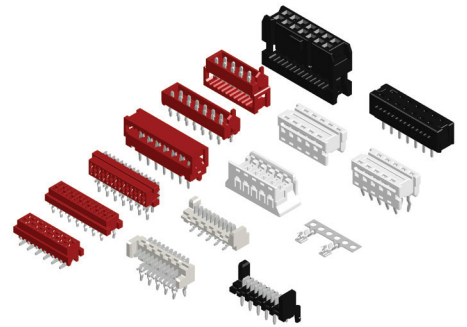

**IDC Connectors**

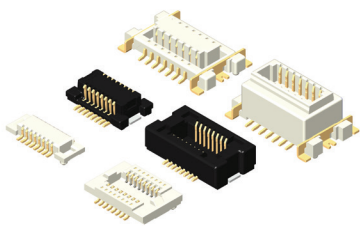

**Board to Board Connectors**

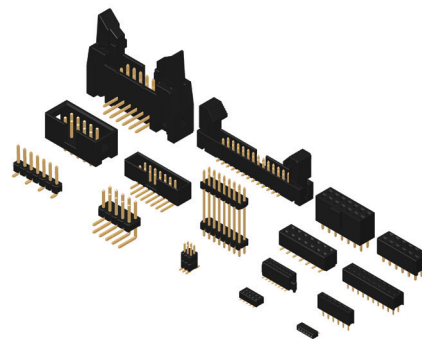

**Pin Headers**

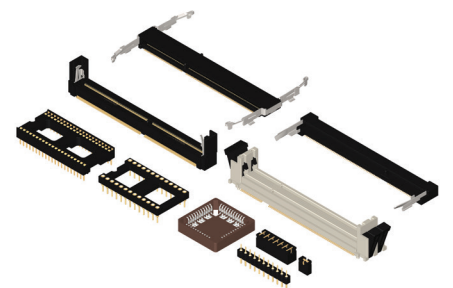

**Socket Connectors**

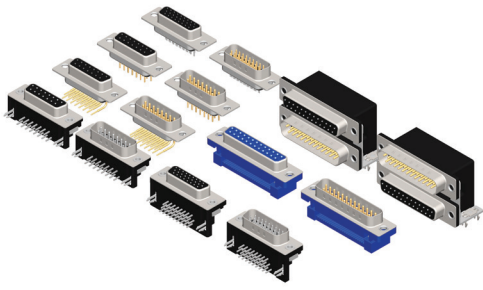

**D-SUB and  
Combo D-SUB Connectors**

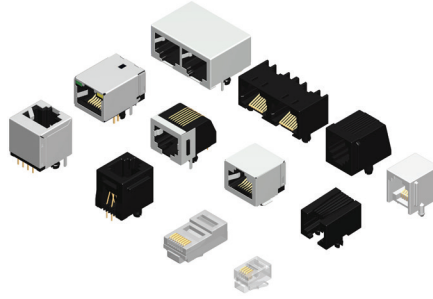

**Modular Jack Connectors**

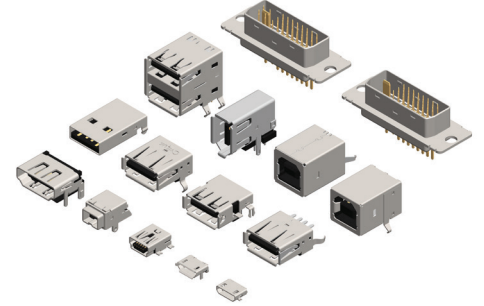

**I/O Connectors**



**USB Type C Connectors**

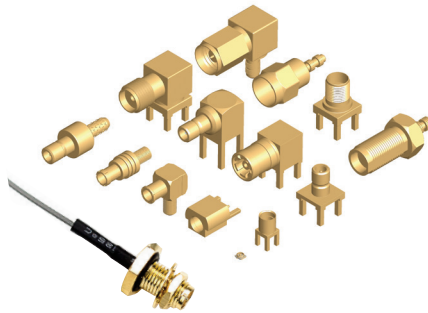

**RF Microwave  
Coaxial Connectors & Cable**



**Pogo Pin Connectors**

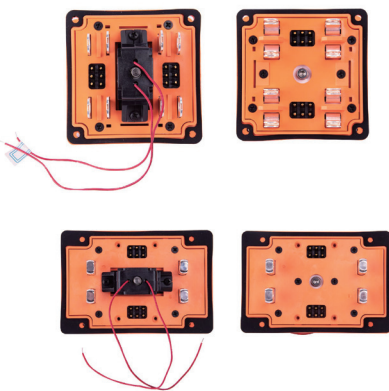

**Fiber Optical Connector  
& Cable**

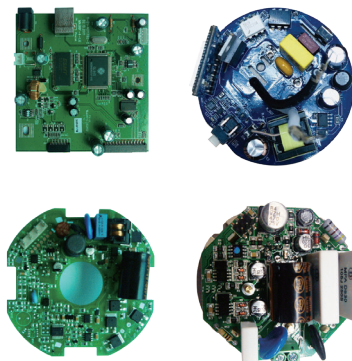

**PCBA & Module**

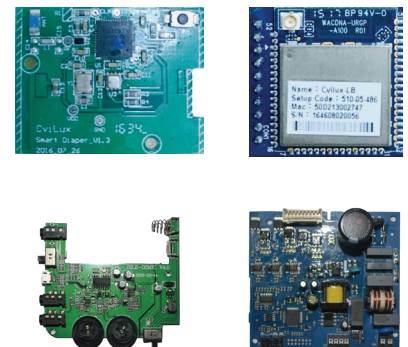

# PRODUCT CATEGORY

## PI High Temperature Film FFC & Cable with PCBA Assemblies

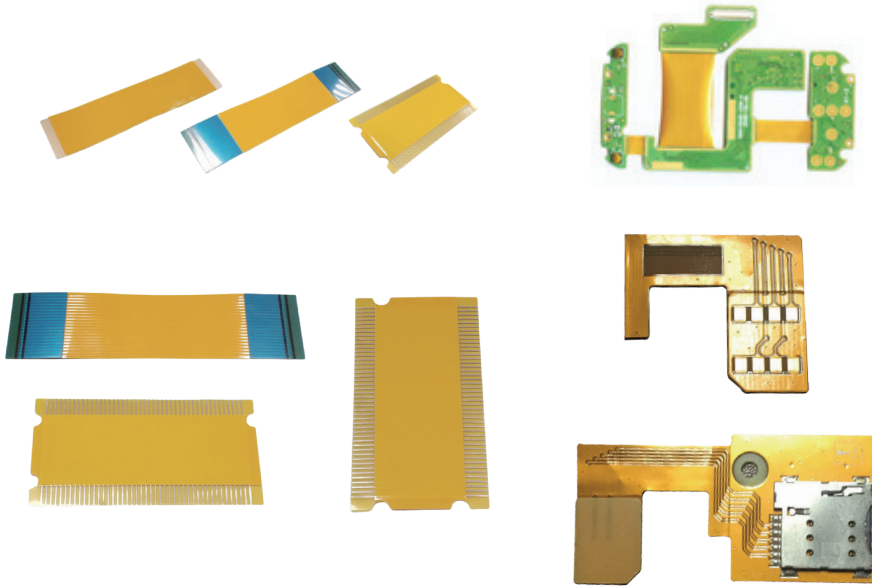

## IDC Cable Assemblies

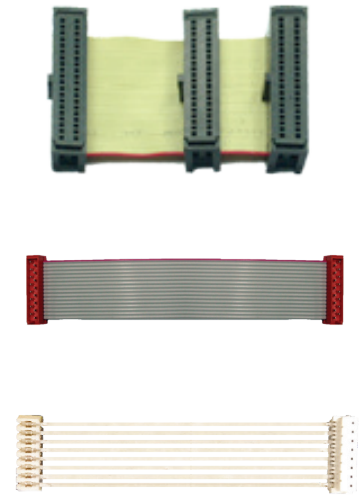

## Type C Cable & Adapter



## HDMI AOC Cable





## STATEMENT OF ENVIRONMENTAL FRIENDLY POLICY

As members of global community, we should all be aware of limited resource consumption and increasing pollution's impact to earth. Our next generation and living animals could live in a dangerous environment without our efforts. Because of this, CviLux Corporation commits to provide environmental friendly products to its clients by using less energy and efficient production. CviLux spirit is to preach such green mind to all the employees and partners who are working closely with us.

Definition:

RoHS Compliant and Lead Free Soldering Process

This letter is released to explain the difference between RoHS compliant and Lead Free Soldering Process. These terms confused R&D designers a lot when they need to select right components and processes for their designs. With this letter, we hope to minimize the confusion and clarify these terms to any one who is interested in this topic.

- RoHS compliant: Indicates raw material of product contained forbidden material within the limitation defined by RoHS directive 2011/65/EU & 2015/863/EU.

- Lead Free Soldering Process: Indicates products themselves can stand specific soldering profile such as J-STD-020C/D or SS-00254.

Currently, there are still no fixed lead free soldering process can be adopted to all kinds of components. For SMT components, the most widely used norms are J-STD-020C/D and SS-00254. As for THT components, JESD22-B106C is the most popular one. CviLux has already set these norms as the standard processes to follow. The details of related soldering temperature of above norms can be found in CviLux product specifications.

Besides, there is still one important concept- It is not a must for RoHS compliant components to adapt Lead Free soldering process. In some cases, it is possible that components are RoHS compliant but not available for lead free soldering process. On the contrary, components available for lead free soldering process are always RoHS compliant. One obvious example is that when cable assemblies can meet RoHS standard, it refers to that the raw materials are environmental friendly only but nothing related to lead free soldering process. PCB components apply the same to the above.

Halogen Free

Halogens are 5 non-metallic elements in group VIIA of the periodic table Fluorine, Chlorine, Bromine, Iodine, Astatine.

Halogens exists, at room temperature, in all three status, Solid ( Iodine, Astatine), Liquid ( Bromine) and Gas ( Fluorine, Chlorine). Currently, only 2 of these 5 elements are normative by IEC, which are Cl and Br.

Why does Halogen Free become new challenges to connector manufacturers? Because the common used connector raw materials like PA66 and PBT are without fire resistance characteristic originally, to strengthen fire resistance characteristic in connector raw materials, Brominated Flame Retardants are used as additive. However, with more and more emphasis on the importance of Halogen Free products, the use of Brominated Flame Retardants becomes more and more difficult and is restricted by content. To adapt this world wide trend, CviLux has had set its standard of Halogens Free policy according to IEC 61249-2-21 and produce the products since Jan. 2008.

- 900 ppm maximum Cl.
- 900 ppm maximum Br.
- 1500 ppm total Halogens.

Meanwhile, as the research of alternative materials/solutions for better performance plastics is progressing, CviLux will take part in this trend and provide its customers with latest technical support.

### Requirement for install

© Android 7.0 above, iOS 11.0 above.



#### Step 1. iOS/Google Play Key Word Search: CVILUX



#### Step 2. Click download on the APP

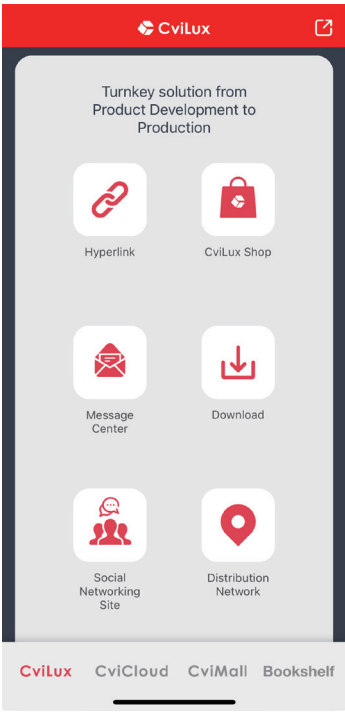

#### Step 3. Download E-Catalogue

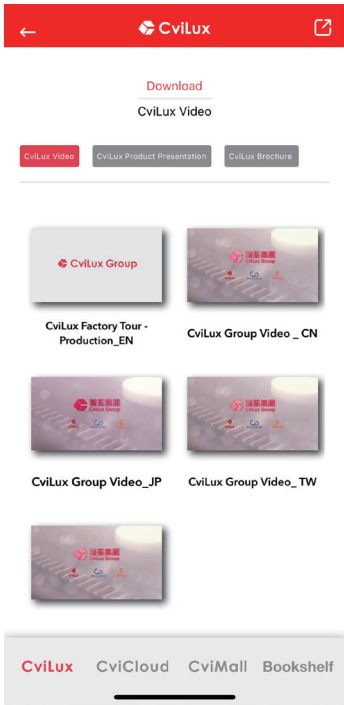

#### Step 4. General Catalogues on Bookshelf



: RoHS Compliant

: TUV Certified

: UL Certified

: Lead-Free soldering process available

: Halogen-Free

Series	Pitch(mm/inch)	Description	
<b>A. FFC / FPC Connectors</b>			
System CF		Construction of Connector	1
		Connection Combinations of Connector and FFC Cable	3
CF58	0.30(.012")	H=0.90 SMT ZIF FFC/FPC Connectors(Back Lock)	4
CF38	0.30(.012")	H=1.00 SMT ZIF One-Touch FFC/FPC Connectors	5
CF30	0.30(.012")	H=1.25 SMT ZIF One-Touch FFC/FPC Connectors	6
CF94	0.30(.013")	ZIF FPC CONN.	7
CF98	0.40()	H=1.20 ZIF FFC/FPC Connectors (Back Flip)	8
CF86	0.50(.020")	H=0.90 ZIF Side Entry SMT Type FFC/FPC Connectors	9
CF42	0.50(.020")	H=0.96 SMT ZIF One-Touch FFC/FPC Connectors (Back Flip)	11
CF35	0.50(.020")	H=0.96 SMT ZIF One-Touch FFC/FPC Connectors	14
CF87	0.50(.020")	H=0.98 ZIF Side Entry SMT Type FFC/FPC Connectors (Back Flip)	15
CF92	0.50(.020")	H=1.22 SMT ZIF One-Touch FFC/FPC Connectors	16
CF55	0.50(.020")	H=1.25 SMT ZIF One-Touch FFC/FPC Connectors	17
CF88	0.50(.020")	H=1.57 ZIF Side Entry SMT Type FFC/FPC Connectors (Back Flip)	18
CF69	0.50(.020")	H=1.75 SMT LIF One-Touch FFC/FPC Connectors	19
CF39	0.50(.020")	SMT One - Touch FFC/FPC Connectors	20
CF75	0.50(.020")	SMT One-Touch FFC/FPC Connectors	21
CF82	0.50(.020")	H=2.00 SMT ZIF One-Touch FFC/FPC Connectors	22
	1.00(.039")	H=2.00 SMT ZIF One-Touch FFC/FPC Connectors	23
CF76	0.50(.020")	H=2.10 SMT LIF FFC/FPC Connectors	24
CF85	0.50(.020")	H=2.20 SMT ZIF One-Touch FFC/FPC Connectors	25
CF90	0.50(.020")	H=2.20 ZIF FFC/FPC Connectors	26
CF50	0.50(.020")	H=1.46 SMT ZIF One-Touch FFC/FPC Connectors	29
	1.00(.039")	H=1.46 SMT ZIF One-Touch FFC/FPC Connectors	33
CF61	0.50(.020")	H=1.75 SMT ZIF One-Touch FFC/FPC Connectors	34
CF31	0.50(.020")	H=1.95 SMT ZIF One-Touch FFC/FPC Connectors	35
	1.00(.039")	H=1.95 SMT ZIF One-Touch FFC/FPC Connectors	37
CF34	0.50(.020")	H=1.95 SMT ZIF One-Touch FFC/FPC Connectors	39
CF25	0.50(.020")	H=2.20 SMT ZIF One-Touch FFC/FPC Connectors	41
	1.00(.039")	H=2.20 SMT ZIF One-Touch FFC/FPC Connectors	43
CF11	0.50(.020")	H=2.70 SMT ZIF One-Touch FFC/FPC Connectors (Back Flip)	44
	1.00(.039")	H=2.70 SMT ZIF One-Touch FFC/FPC Connectors (Back Flip)	46
CF23	0.50(.020")	H=1.20 SMT ZIF FFC/FPC Connectors	47
	1.00(.039")	H=1.20 SMT ZIF FFC/FPC Connectors	48
CF20	0.50(.020")	H=2.00 SMT ZIF FFC/FPC Connectors	50
	1.00(.039")	H=2.00 SMT ZIF FFC/FPC Connectors	51
CF27	0.50(.020")	H=1.20 SMT LIF FFC/FPC Connectors	52
	1.00(.039")	H=1.20 SMT LIF FFC/FPC Connectors	53
CF24	0.50(.020")	H=4.20 SMT LIF Vertical FFC/FPC Connectors	54
CFAB	0.50(.020")	H=1.20 ZIF One-Touch FFC/FPC Connectors	55
CF95	0.80(.031")	H=1.50 SMT ZIF FFC/FPC Connectors (Back Flip)	56
CF84	0.80(.031")	H=1.57 SMT ZIF FFC/FPC Connectors (Back Flip)	57
CF32	0.80(.031")	H=1.95 SMT ZIF One-Touch FFC/FPC Connectors	58
CF37	0.80(.031")	H=1.95 SMT ZIF One-Touch FFC/FPC Connectors	59
CF07	1.00(.039")	H=2.60 SMT ZIF FFC/FPC Connectors	60
CF08	1.00(.039")	H=2.60/3.55 SMT LIF & SMT LIF Vertical FFC/FPC Connectors	61

CF09	1.00(.039")	H=2.60/5.50 DIP LIF FFC/FPC Connectors	62
CF73	1.00(.039")	H=3.30 SMT ZIF One-Toach FFC-FPC Connectors	63
CF10	1.00(.039")	H=3.80/5.00 DIP ZIF FFC/FPC Connectors	64
		H=5.20 SMT ZIF FFC/FPC Connectors	65
CF16	1.00(.039")	H=3.80/5.00 DIP LIF FFC/FPC Connectors	66
			67
CF12	1.25(.049")	H=4.00/6.80 DIP LIF FFC/FPC Connectors	68
<b>B. Flat Flexible Cables &amp; LVDS FFC Cables</b>			
System FFC	Introduction		69
		Features & Applications & Connections	70
		Ordering Code & Terminal Types table	71
		Shape, Construction and Dimensions	72
		Feature & Caution	73
		Performance	74
<b>CFF / CFE</b>		Flat Flexible Cable Assemblies - LVDS FFC Cable	75
FFCA	2.54(.100")	Flat Flexible Cable Assemblies	76
<b>C. LVDS Connectors</b>			
CVS1	0.50(.020")	LVDS H=3.70 Socket Connectors for TV	77
CVS3	0.50(.020")	LVDS M/H=2.00 Socket Connectors for Notebook	78
CVS5	0.50(.020")	LVDS M/H=4.00 Socket Connectors for Notebook	79
<b>CVSC</b>		1.00(.039")	5
<b>D. Wire to Board Connectors</b>			
System CI		Connection Combination of Wire to Board Connectors	82
CI20	0.60(.024")	Wire to Board Connectors Housing & SMT Headers	83
CI18	0.80(.031")	Wire to Board Connectors Housing & SMT Headers	84
CI11	1.00(.039")	Single Row Wire to Board Connectors Housing & Terminal	85
		Single Row Wire to Board Connectors SMT Headers	86
		Dual Row Wire to Board Connectors Housing & Terminal	87
		Dual Row Wire to Board Connectors SMT Headers	88
CI16	1.00(.039")	Wire to Board Connectors Housing & Terminal	89
		Wire to Board Connectors SMT Headers	90
	1.00(.039")	Wire to Board Connectors Housing & Terminal	91
		Wire to Board Connectors SMT Side Entry Headers	93
		Wire to Board Connectors Housing & SMT Side/Top Entry Headers	95
CI63	1.20(.048")	Wire to Board Connectors Housing & Terminal & SMT Headers	96
	1.20(.048")	Wire to Board SMT Headers	97
CI40	1.25(.049")	Wire to Board Housing & Terminal	98
		Wire to Board SMT Headers	99
CI42	1.25(.049")	Wire to Board Housing & Terminal	100
	1.25(.049")	Wire to Board SMT Header	101
CI43	1.25(.049")	Wire to Board Connectors Housing & Terminal & SMT Headers	102
CI44	1.25(.049")	Wire to Board Connectors Housing & Terminal	103
		Wire to Board Connectors DIP Headers	104
		Wire to Board Connectors SMT Headers	105
CI45	1.25(.049")	Wire to Board Connectors Housing & SMT Headers	106
CI46	1.25(.049")	Wire to Board Connectors Housing & Terminal	107
		Wire to Board Connectors SMT Headers	108
CIDL	1.25(.049")	Wire to Board Connectors	109
CI15	1.50(.059")	Wire to Board Connectors Housing & Terminal	110
		Wire to Board Connectors DIP & SMT Headers	112
		Wire to Board Latch Type Housing & SMT Headers	113
CIFA	1.50(.059")	Wire to Board Connectors Housing	114

# TABLE OF CONTENT



CIFA	1.50(.059")	Wire to Board Connectors SMT Header	115
CI19	1.50(.059")	Wire to Board Connectors Housing & Terminal	116
		Wire to Board Connectors SMT Headers	117
CI87	1.50(.059")	Wire to Board Connectors Housing & Terminal & SMT Headers	118
CIDW	1.50(.059")	Single Row Wire to Board Housing & Terminal	119
		Wire to Board Connectors SMT Headers	120
CIEJ	1.50(.059")	Single Row Wire to Board Housing & Terminal	121
		Single Row Wire to Board SMT Headers	122
CI07	1.80(.071")	Wire to Board Connectors Housing & Terminal	123
		Wire to Board Connectors SMT Headers	124
CI01	2.00(.079")	Single Row Wire to Board IDC Housing & Terminal	125
		Single Row Wire to Board Connectors DIP & SMT Headers	128
		Single Row Wire to Board Latch Type Housing & SMT Header	129
		Dual Row Wire to Board Connectors Housing & Terminal	130
		Dual Row Wire to Board Connectors DIP Headers	131
CI02	2.00(.079")	Board In Connectors	132
CI06	2.00(.079")	Wire to Board Connectors Housing & Terminal	133
		Wire to Board Connectors DIP & SMT Headers	134
CI08	2.00(.079")	Wire to Board Connectors SMT & DIP Headers	135
CI10	2.00(.079")	Wire to Board Connectors SMT Headers	138
CIDX	2.00(.079")	Single Row Wire to Board Housing & Terminal	139
		Wire to Board Connectors SMT Headers	140
CIDY	2.00(.079")	Single Row Wire to Board Housing & Terminal	141
		Wire to Board Connectors DIP Headers	142
CID9	2.00(.079")	Single Row Wire to Board Housing & Terminal	143
		Single Row Wire to Board SMT Headers	144
CIEG	2.00(.079")	Single Row Wire to Board Housing & Terminal	146
CIE4	2.00(.079")	Daul Row Wire to Board to Board DIP Headers	148
CIEP	2.50(.098")	ST. PIN HEADER;With Kinked & Peg	150
CIEW	2.00(.079")	Daul Row Wire to Board to Board DIP Headers	152
CI21	2.50(.098")	Wire to Board Connectors Housing & Terminal	153
		Wire to Board Connectors DIP Headers	154
CI22	2.50(.098")	Wire to Board IDC Connectors Housing & Terminal	155
		Wire to Board IDC Connectors Housing & IDC Cable	156
		Wire to Board IDC Connectors Connectors DIP Header	157
CI25	2.50(.098")	Wire to Board Connectors Housing & Terminal	158
		Wire to Board Connectors DIP Headers	159
CI30	2.50(.098")	Wire to Board Connectors DIP Header	160
CI60	2.50(.098")	Wire to Board Connectors DIP Header & Housing & Terminal	161
CI4	2.50(.098")	Wire to Board Connectors SMT Headers	162
CI31	2.54(.100")	Wire to Board Connectors Housing & Terminal	163
		Wire to Board Connectors DIP Headers	164
CI39	2.54(.100")	Wire to Board Connectors SMT Headers	165
CI83	2.54(.100")	Friction Lock Breakaway Headers	166
CID2	2.54(.100")	IDC type Connectors	167
CID7	2.54(.100")	Wire to Board Housing/Terminal/Straight Headers	168
CI51	3.96(.156")	Wire to Board Connectors Housing & Terminal	169
		Wire to Board Connectors DIP Headers	170
CI52	3.96(.156")	Wire to Board Connectors Housing & Terminal	171
		Wire to Board Connectors DIP Headers	172
		7.92(.312")	Wire to Board Connectors DIP Headers
CI82	3.96(.156")	Friction Lock Breakaway Headers	174

CI77 /CI78	3.96(.156")	Breakaway Pin Headers	175
CID1	4.00(.157")	Wire to Board Connectors SMT Header	176
CI55	5.08(.200")	Wire to Board Connectors	177
<b>E. Power Connectors</b>			
System CP		Connection Combination of Power Connectors	178
CP30	1.25(.049)	Battery Male Connectors	180
CP75	1.50(.059)	Board to Board Receptacle Connector	181
		Board to Board Plug Connector	182
CP14	1.50(.059")	Single Row Side Entry SMT Headers	183
CP15	1.50(.059")	SMT Headers	186
<b>CPB1</b>		Waterproof Connectors	187
CPB2	2.00(.079")	Waterproof Connectors	191
CP25	2.50(.098")	Receptacle Connectors	192
CP35	3.00(.118")	Single Row Housing Connectors	193
		Single Row Board Mount Headers	194
		Single Row Side Entry SMT Headers	195
		Single Row Top Entry SMT Headers	196
		Dual Row Receptacle Connectors	197
		Dual Row Plug Connectors	198
		Dual Row Board Mount Headers	199
		Dual Row Side Entry SMT Headers	201
		Dual Row Top Entry SMT Headers	202
CP62	3.00(.118")	Wire to Board Connectors	204
CP-01	4.20(.165")	Power Connectors	205
CP-011	4.20(.165")	Receptacle Connectors	206
		Blind Mating Panel Mount Receptacle Connectors	207
		Receptacle Board Mount Connectors	208
		Assembly Power Connectors	209
CP-012	4.20(.165")	Plug Connectors	210
CP-013	4.20(.165")	Straight DIP Solder Headers	213
CP-014	4.20(.165")	Right Angle DIP Solder Headers	216
CP32	5.08(.200")	Power Connectors	217
CP33	5.08(.200")	IDC & Board Mount Receptacle Power Connectors	218
CP60	5.70(.224")	Dual Row Receptacle & Header	220
CP08	6.35(.250")	Single Row Power Connector	224
CPF1		High-Voltage Plug Connectors	226
CPF2		High-Voltage Plug Connectors	228
<b>F. IDC Connectors</b>			
System CA		Connection Combination of IDC Connectors	229
CA30	1.27(.050")	Male IDC & DIP Type Connectors	230
	1.27(.050")	Male IDC SMT Type Connectors	231
CA31	1.27(.050")	Flat Cable - IDC DIP Plugs	232
<b>CA30&amp;CA31</b>		Flat Cable Assemblies	233
CA32	1.27(.050")	Female DIP Type Connectors	234
	1.27(.050")	Female SMT Type Connectors	235
CA33	1.27(.050")	IDC & Crimping Type Connectors	236
CM19		Pull-off tongs for CA33	237
CA34	1.27(.050")	Flat Cable - IDC DIP Plugs	238
CA35	1.27(.050")	Male DIP Type Connectors	239
	1.27(.050")	Male SMT Type Connectors	240
	1.27(.050")	Female DIP Type Connectors	241
CW03	1.27(.050")	Flat Ribbon Cable	242

# TABLE OF CONTENT



CA11	2.00(.079")	Center Spacing Flat Cable - IDC Sockets	243
CA21	2.54(.100")	Center Spacing Flat Cable - IDC Sockets	244
CA23	2.54(.100")	Center Spacing Flat Cable - IDC DIP Plugs	245
<b>G. Board To Board Connectors</b>			
System CB		Connection Combination of Board To Board Connectors	246
		Board To Board Connectors Selection Index	249
CBRH	0.40(.016")	Board to Board Connectors	250
CBRQ	0.40(.016")	Board to Board Connectors	251
CBRB	0.50(.020")	Board To Board Connectors	253
CBRC	0.50(.020")	Board To Board Connectors	255
CBRE	0.50(.020")	Board To Board Connectors	257
CBRD	0.80(.031")	Board To Board Connectors	259
CBC3	0.80(.031")	Dual Row Female Headers	260
CB03	1.00(.039")	SMT Type Single Row Pin Headers	261
CB12	1.00(.039")	Dual Row Female Headers	261
CB01	1.27(.050")	Single Row Female Headers	262
CB50	1.27(.050")	Dual Row Female Headers	263
CBC1	1.27(.050")	Dual Row Female Headers	265
CB22	2.00(.079")	Single Row Female Headers	266
CB74	2.00(.079")	Dual Row Female Headers	267
CB76	2.00(.079")	Dual Row Female Headers	268
CB33	2.54(.100")	Single Row Dual Entry Female Headers	269
CB37	2.54(.100")	Single Row Female Headers	269
CB39	2.54(.100")	Single Row Female Headers	270
CB41	2.54(.100")	Dual Row Female Headers	271
CB83	2.54(.100")	Dual Row Female Headers	272
CB85	2.54(.100")	Dual Row Female Headers	272
CB96	2.54(.100")	Dual Row Elevated Female Headers	273
CB91	2.54(.100")	Dual Row Female Headers	274
CB94	2.54(.100")	Dual Row Female Headers	275
CB97	2.54(.100")	Dual Row Side Entry Female Headers	276
CBA7	2.00(.079")	Dual Row Female Headers	276
CGB1		Pogo Pin Connectors	278
<b>H. Pin Header Connectors</b>			
CHC3	0.80(.031")	Dual Row SMT Pin Headers	279
CH07	1.00(.039")	Single Row Board Mount Connectors	280
CH16	1.00(.039")	Dual Row Pin Headers	280
CH01	1.27(.050")	Single Row Pin Headers	281
CH02	1.27(.050")	Single Row Pin Headers	282
CH03	1.27(.050")	Single Row Dual Bodies Pin Headers	283
CH06	1.27(.050")	Straight SMT Dual Row Shrouded Headers	284
CH51	1.27(.050")	Dual Row Pin Headers	286
CH52	1.27(.050")	Dual Row Pin Headers	288
CH57	1.27(.050")	Dual Row Dual Bodies Pin Headers	289
CHC2	1.27(.050")	Dual Row Pin Headers	292
CH60	1.27*1.27mm	Right Angle Dual row board mount pin header	293
CH11	2.00(.079")	Single Row SMT Pin Headers	295
CH21	2.00(.079")	Single Row Dual Bodies Pin Headers	296
CH70	2.00(.079")	Straight SMT Dual Row Shrouded Headers	296
CH71	2.00(.079")	Dual Row SMT Pin Headers	297
	2.00(.079")	Dual Row Pin Headers	298
CH72	2.00(.079")	Dual Row Pin Headers	299

CH74	2.00(.079")	Dual Row Pin Headers	300
CH75	2.00(.079")	Dual Row Dual Bodies Pin Headers	301
CH79	2.00(.079")	Dual Row Pin Headers	303
CH34	2.54(.100")	Single Row Dual Bodies Pin Headers	304
CH31	2.54(.100")	Single Row Pin Headers	305
CH81	2.54(.100")	Dual Row SMT & DIP Pin Headers	307
CH85	2.54(.100")	Dual Row Dual Bodies Pin Headers	308
CH87	2.54(.100")	Box Headers	309
CH88	2.54(.100")	Shrouded Box Headers	310
<b>I. Sockets</b>			
CS76	0.50(.020")	NGFF Connectors	311
CS59	0.80(.031")	Mini PCI 4.0H/2.1H 52pin Connectors	312
CS78	1.27(.050")	Board to Board Right Angle DIP Connector	313
CS01	2.54(.100")	Dual Row Multiple Shunts	314
<b>CS07</b>	2.54(.100")	DIP Socket - Machined contacts	315
CS09	2.54(.100")	Single in Line Adapter Strip	316
CS10	2.54(.100")	Single in Line SIP Socket	316
CS74		PCI Express Edge Card Connector	317
CSM2		Micro SIM Card Connectors	318
<b>J. D-SUB Connectors</b>			
		D-Sub Shell Size & Printed Circuits Board Hole Patterns	319
		High density D-Sub Straight / Right Angle DIP solder PCB hole patterns	320
		D-Sub Accessories & PCB Mounting Options	321
CD01		High Density Solder D-Sub	322
CD51		Solder D-Sub	323
CD52		Crimp Clip D-Sub & Terminal	325
CD53		Straight DIP Solder D-Sub	326
<b>CD61</b>		8.10mm Footprint Right Angle DIP Solder D-Sub	327
CD62		8.10mm Footprint EMI Right Angle DIP Solder D-Sub	328
CD91		Flat Cable - IDC D-Sub	329
CD81		Stacked Right Angle DIP Solder D-Sub	331
CD71		Machined Contact Solder Cup D-Sub	333
CD72		Machined Contact Straight DIP Solder D-Sub	335
CD73		8.10mm Footprint Right Angle DIP solder D-Sub	337
COMBO D-SUB		Combo D-sub Technical Specifications	338
		Contact Arrangements/ Mounting Style options	339
		Coaxial Contact for Combination D-Sub	340
		High Power Contact for Combination D-Sub	342
		Combination D-Sub Housing	345
		Coaxial Straight DIP Combination D-Sub	348
		Coaxial Right Angle DIP Combination D-Sub	351
		20A High Power Straight DIP Solder Combination D-Sub	354
		40A High Power Straight DIP Solder Combination D-Sub	357
		20A High Power Right Angle DIP Solder Combination D-Sub	360
		40A High Power Right Angle DIP Solder Combination D-Sub	363
<b>K. Telephone / Modular Jack Connectors</b>			
CJ04		Board Mount Telephone Jacks	364
CJ07		Board Mount Telephone Jacks	365
CJ36		Board Mount Telephone Jacks	365
CJ31		Board Mount Telephone Jacks	367
CJ46		Board Mount Telephone Jacks	368
CJ47		Board Mount Telephone Jacks	368

# TABLE OF CONTENT



CJ58	Board Mount Telephone Jacks	368
CJ48	Board Mount Telephone Jacks	369
CJ59	Board Mount Telephone Jacks	370
CJ91	Board Mount Telephone Jacks	371
CJ97	Board Mount Telephone Jacks	373
CJP1	Telephone Modular Plugs	374
CJP2	Telephone Modular Plugs	375
CJB1	Telephone Modular Jack RJ45	376
CJCJ	Telephone Modular Jack RJ45	377
<b>L. I/O Connectors</b>		
CU01	USB 2.0 Type-A Board Mount Receptacle and SMT Plug Connectors	378
	USB 2.0 Type-A Receptacle Connectors	379
CU02	USB 2.0 Type-B Receptacle Connectors	380
CU04	Mini USB2.0 5 Circuits Receptacle SMT/DIP Connectors	381
CU09	Micro USB 2.0 Connectors	382
CU05	IEEE 1394 Shielded I/O Receptacle Connectors	383
CU11	HDMI Receptacle Connectors	384
USB-C	USB TYPE C Technical Specifications	386
CU30	USB 3.1 Type C Plug SMT Type Connectors (Parallel pin position)	387
<b>CU30</b>	USB 3.1 Type C Plug SMT Type Connectors	389
CU30	USB 3.1 Type C Receptacle SMT Type Connectors	391
CU31	USB3.1 Type C Plug Clamp Type Connectors	392
CU31	USB3.1 Type C Receptacle Clamp Type Connectors	393
CU32	USB Type C Receptacle SMT Type Connectors	402
CU33	USB 2.0 Type C Receptacle Vertical Type Connectors	403
CU33	USB 2.0 Type C Plug Type Connectors	404
CU34	USB 2.0 Type C Receptacle SMT Type Connectors	405
CU35	USB 2.0 Type C Receptacle Connectors	406
CU39	USB 2.0 Type C Receptacle Connectors	407
<b>M. RF / Microwave Coaxial Connectors</b>		
CRA	Micro Coaxial Connectors & Cable	408

Construction of Connector

CF

◎ Zero Insertion Force Type (ZIF)

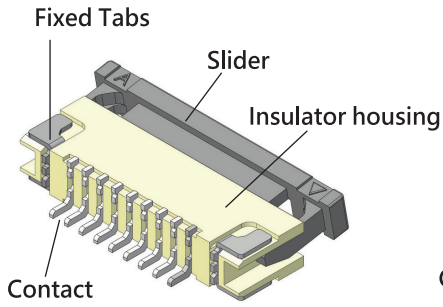

Slider Type

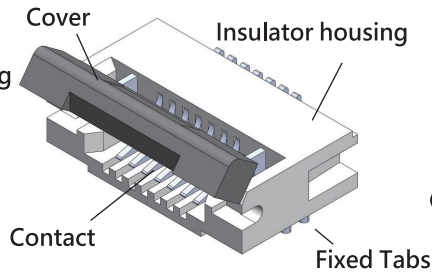

Front Flip actuator

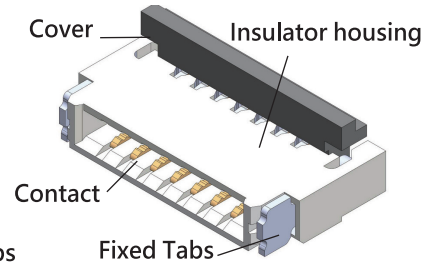

Back Flip actuator

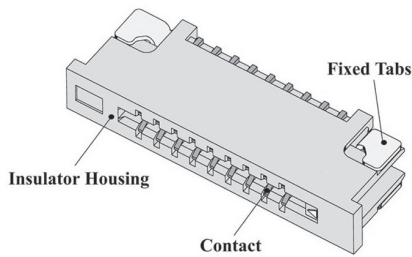

◎ Low Insertion Force Type (LIF)

Applications

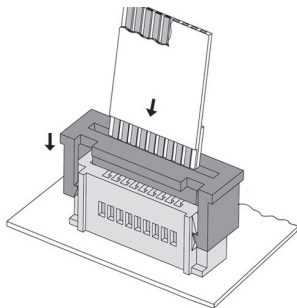

◎ Top Entry

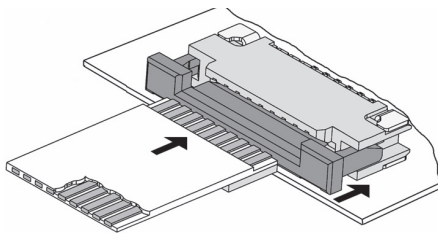

◎ Side Entry to Upside Contact Connector

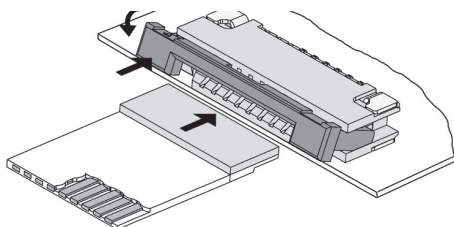

◎ Side Entry to Downside Contact Connector

Connection Combinations of Connector and FFC Cable

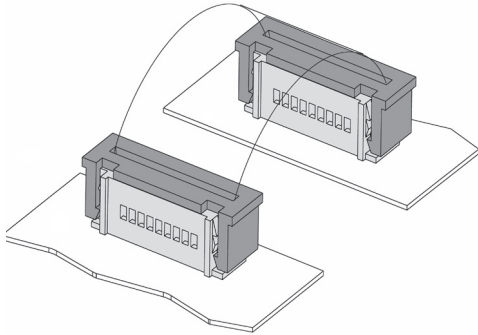

**Both Ends with Zero Insertion Force Type Connector**

- Top Entry to Top Entry

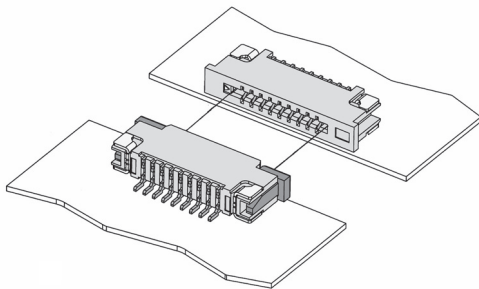

**Low Insertion Force Connector to Zero Insertion Force Connector**

- Side Entry to Side Entry

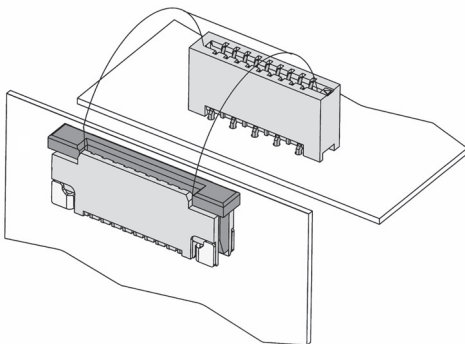

**Low Insertion Force Connector to Zero Insertion Force Connector**

- Top Entry to Side Entry

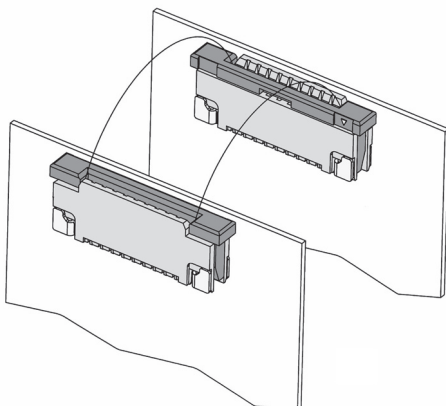

**Both Ends with Zero Insertion Force Connector**

- Side Entry to Side Entry

Connection Combinations of Connector and FFC Cable

CF

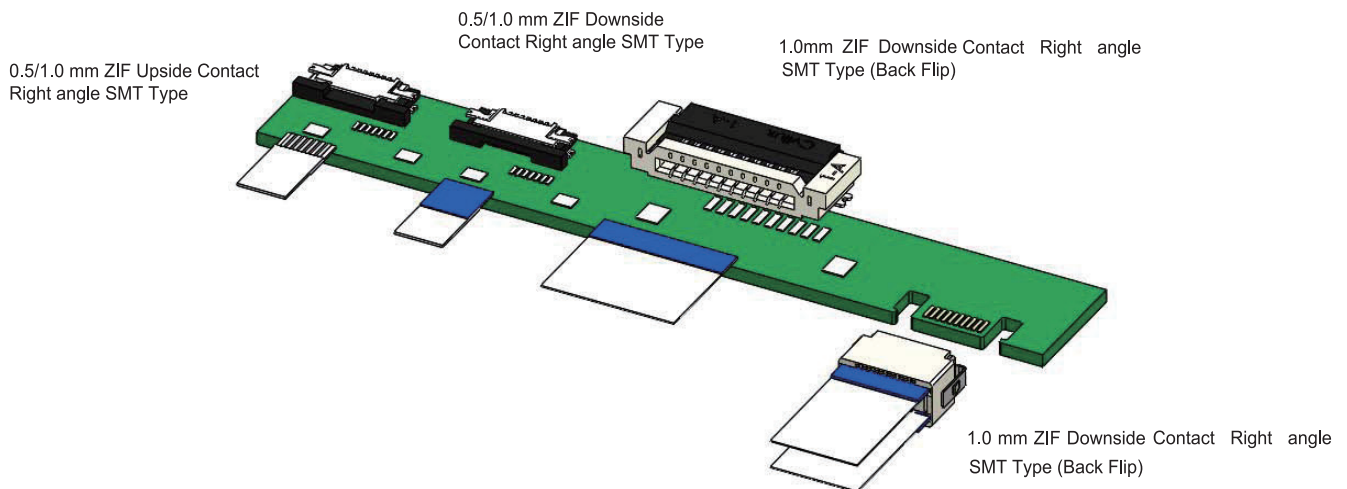
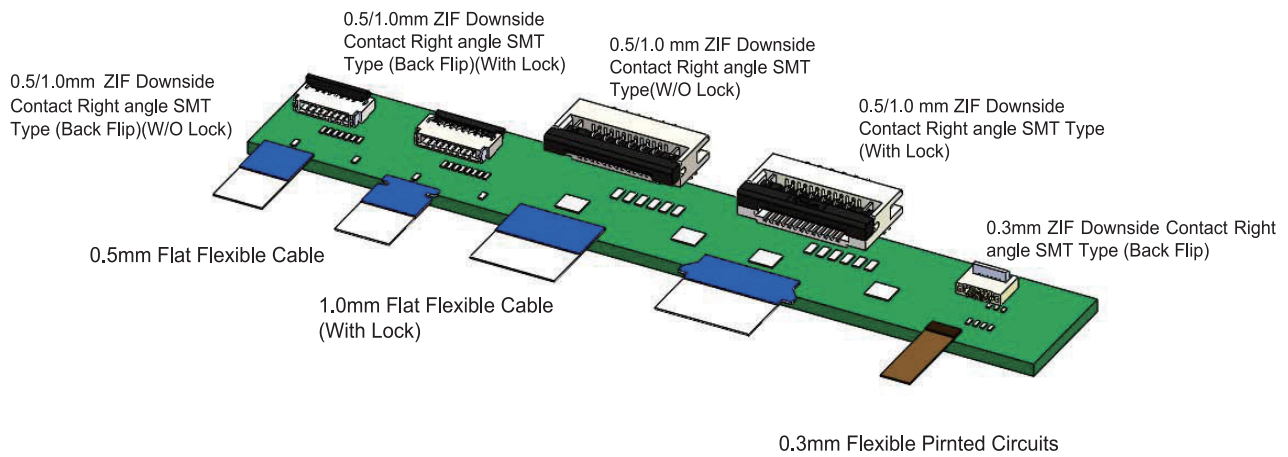
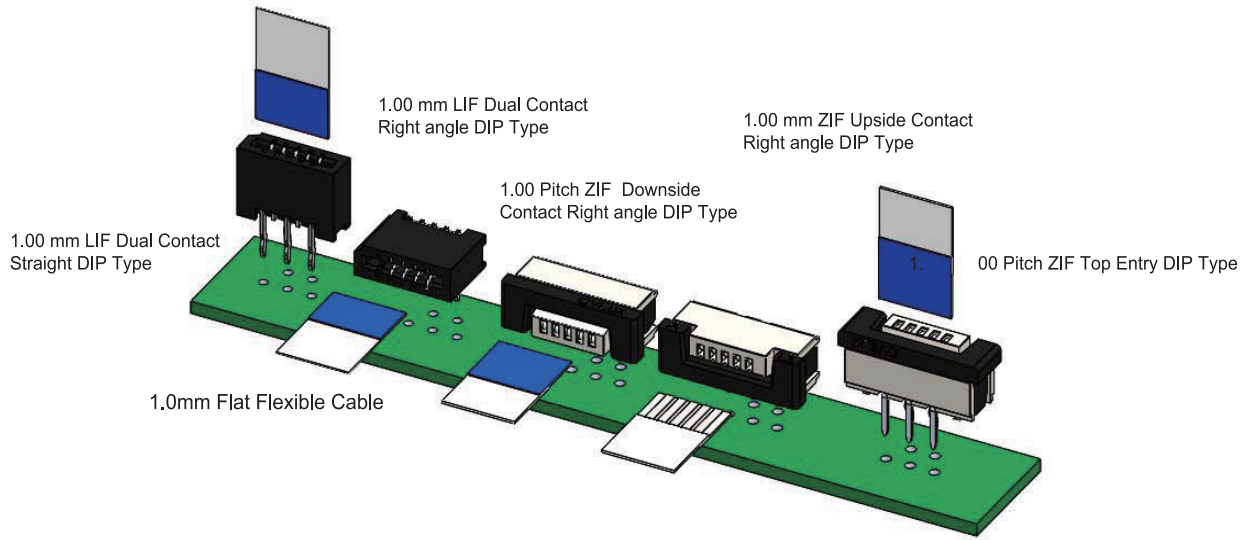

**CF58 Series 0.30mm (.012")H=0.90 SMT ZIF FFC/FPC Connectors (Back Flip actuator)**

- ⊙ 0.90mm above the board
- ⊙ Insulation: High temperature plastic UL 94V-0, Color Black
- ⊙ Cover: High temperature plastic UL 94V-0, Color Brown
- ⊙ Designed easy for FPC installation and reliable operation

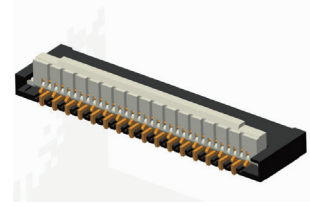

RoHS Compliant

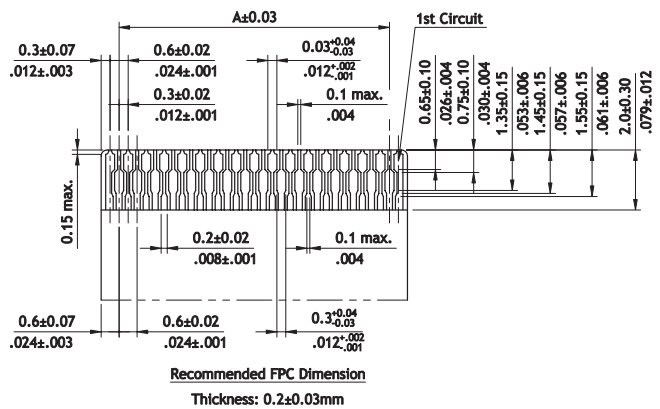
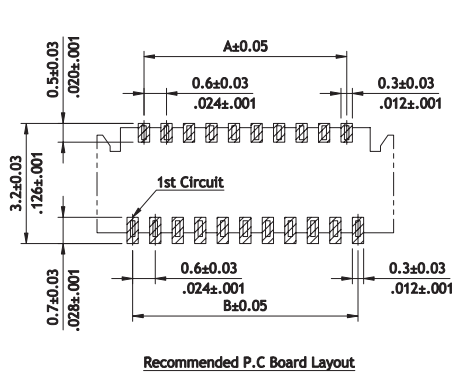
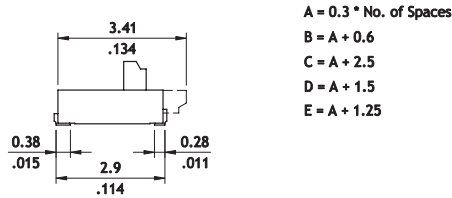
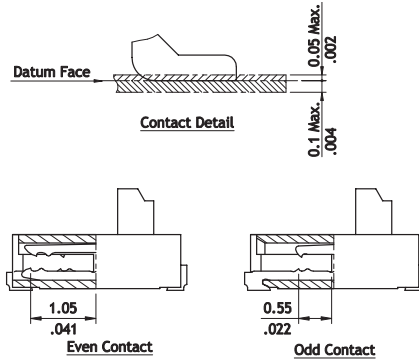
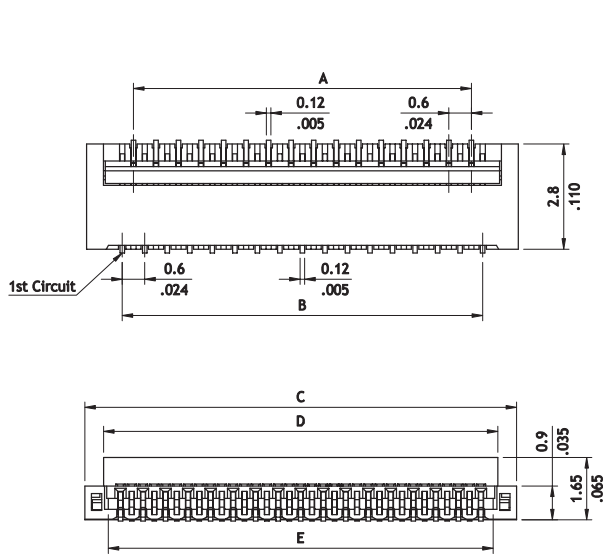

Ordering Code

① ② ③ ④ ⑤ ⑥ ⑦ ⑧  
**CF58 61 F H 1 R A - NH**

- ① Series No.
- ② No. of Circuits: 07 ~ 61 (Available: 7, 11, 23, 25, 51, 61) \*Circuits not found above please consult manufacturer\*
- ③ Plating Code: F = Selective Gold flash over Nickel
- ④ Contact Style: H = Side Entry
- ⑤ Color: 1 = Black
- ⑥ Packing: R = Tape & Reel
- ⑦ Other Options: 0 = Standard (Only for 7pin) A = Standard \*Special option consult manufacturer
- ⑧ NH = For Lead Free IR process and Halogen-Free

**CF38 Series 0.30mm(.012") H=1.00 SMT ZIF FFC/FPC Connectors (Front Flip actuator)**

CF

- ⊙ 1.0mm above the board
- ⊙ FPC zero insertion force and high retention force
- ⊙ Insulator: High temperature plastic UL 94V-0, Color Black
- ⊙ Cover: High temperature plastic UL 94V-0, Color Nature
- ⊙ Designed easy for FPC installation and reliable operation
- ⊙ With metal fixed tabs to secure connector in place

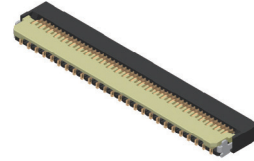

RoHS Compliant

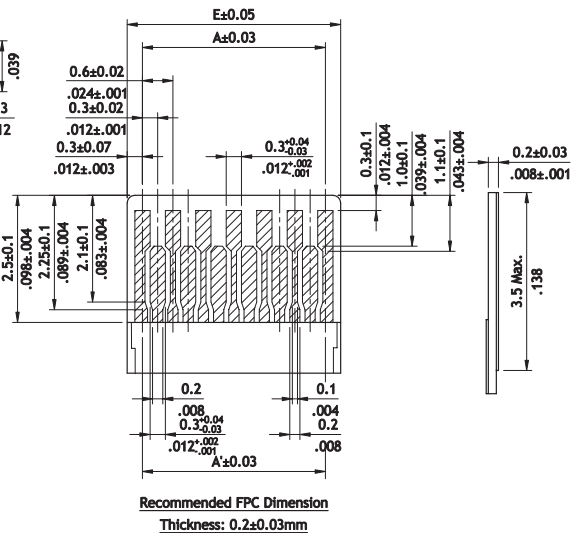
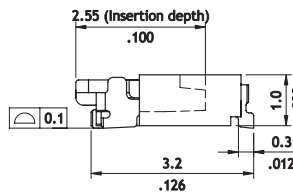
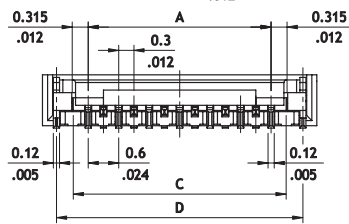
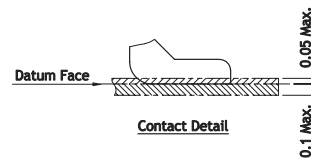
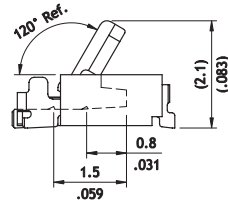
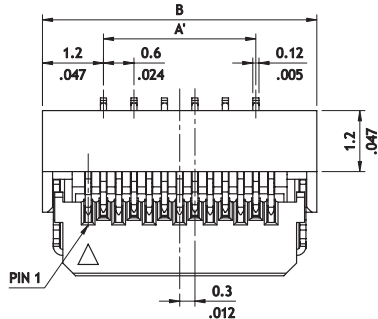

- A = 0.3 \* No. of Spaces
- A' = A - 0.6
- B = A + 1.8
- C = A + 0.63
- D = A + 1.25
- E = A + 0.6

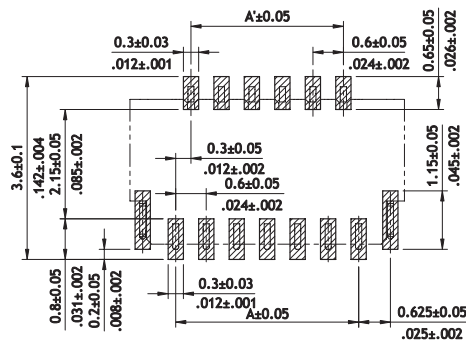

Recommended P.C. Board Layout

**Ordering Code**

① ② ③ ④ ⑤ ⑥ ⑦  
**CF38 39 2 D 1 R0 - NH**

- ① Series No.
- ② No. of Circuits: 13 ~ 71  
 (Available: 13, 15, 21, 23, 25, 31, 35, 39, 41, 45, 51, 57, 61, 71)  
 \*Circuits not found above please consult manufacturer\*

- ③ Plating Code: 2 = Gold flash over Nickel
- ④ Contact Style: D = Downside Contact
- ⑤ Color: 1 = Black
- ⑥ Packing: R0= Tape & Reel
- ⑦ NH = For Lead Free IR process and Halogen-Free

**CF30 Series 0.30mm(.012") H=1.25 SMT ZIF One-Touch FFC/FPC Connectors**

- ⊙ 1.25mm above the board
- ⊙ FPC zero insertion force and high retention force
- ⊙ Insulator: High temperature plastic UL 94V-0, Color Nature
- ⊙ Cover: High temperature plastic UL 94V-0, Color Black
- ⊙ Designed easy for FPC installation and reliable operation
- ⊙ With metal fixed tabs to secure connector in place
- ⊙ Accepts 0.2mm thickness FPC

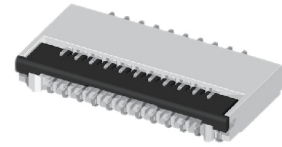

RoHS Compliant   

P/N **CF30\*\*2DORA**

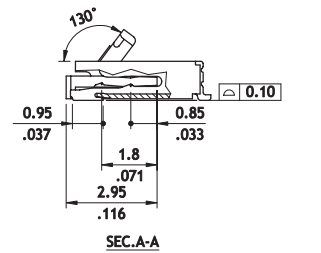
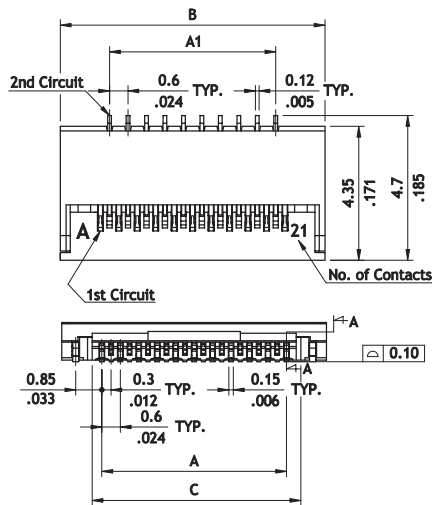

A = 0.3 \* (No. of Contacts - 1)  
 A1 = A - 0.6  
 B = A + 2.6  
 C = A + 0.63

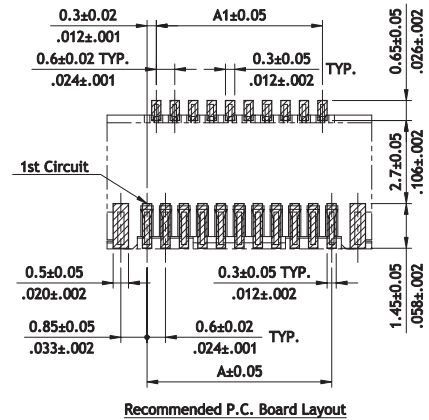

P/N **CF30\*\*2DORB**

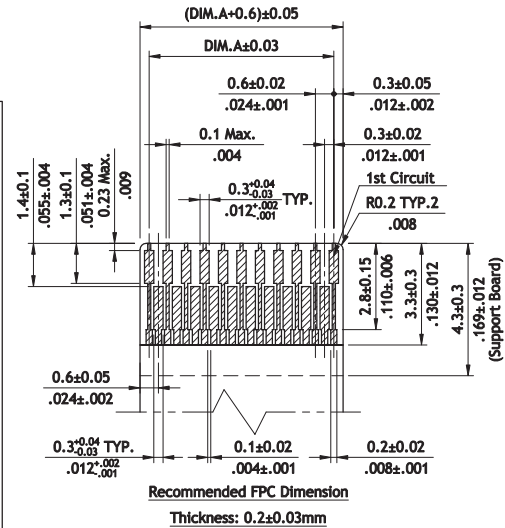
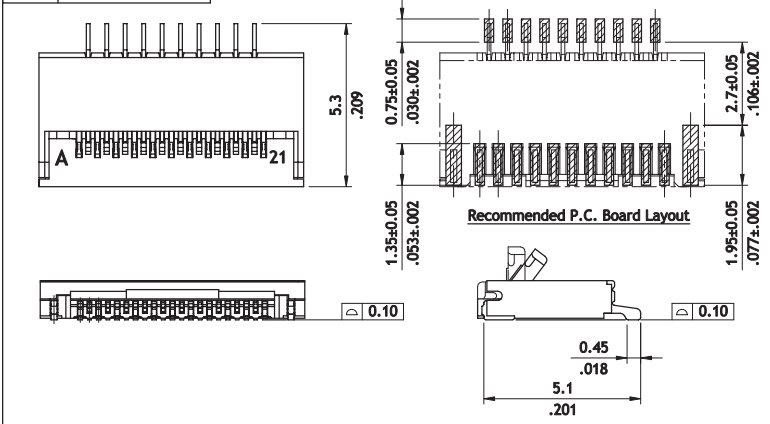

**Ordering Code**

① ② ③ ④ ⑤ ⑥ ⑦ ⑧  
**CF30 45 2 D 0 R A - NH**

- ① Series No.
- ② No. of Circuits: 11 ~ 45  
 (Available: 11,21,25,31,35,37, 39,41,45)  
 \*Circuits not found above please consult manufacturer\*

- ③ Plating Code:  
 2 = Gold flash over Nickel
- ④ Contact Style:  
 D = Downside Contact
- ⑤ Color: 0 = Nature
- ⑥ Packing: R = Tape & Reel

- ⑦ Other Options:  
 A = Lead-Less Type  
 B = Lead Type  
 \* Special options consult manufacturer
- ⑧ NH = For Lead Free IR process and Halogen-Free

**CF94 Series 0.30mm(.012") H=3.60 SMT Vertical FFC/FPC Connectors**

CF

- ⊙ 3.6mm above the board
- ⊙ FFC/FPC zero insertion force and high retention force
- ⊙ Insulator: High temperature plastic UL 94V-0, Color Nature
- ⊙ Cover: High temperature plastic UL 94V-0, Color Black
- ⊙ Designed easy for FPC installation and reliable operation
- ⊙ With metal fixed tabs to secure connector in place

**NEW**

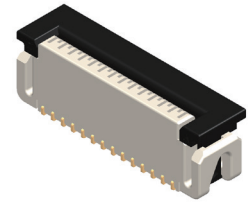

RoHS Compliant

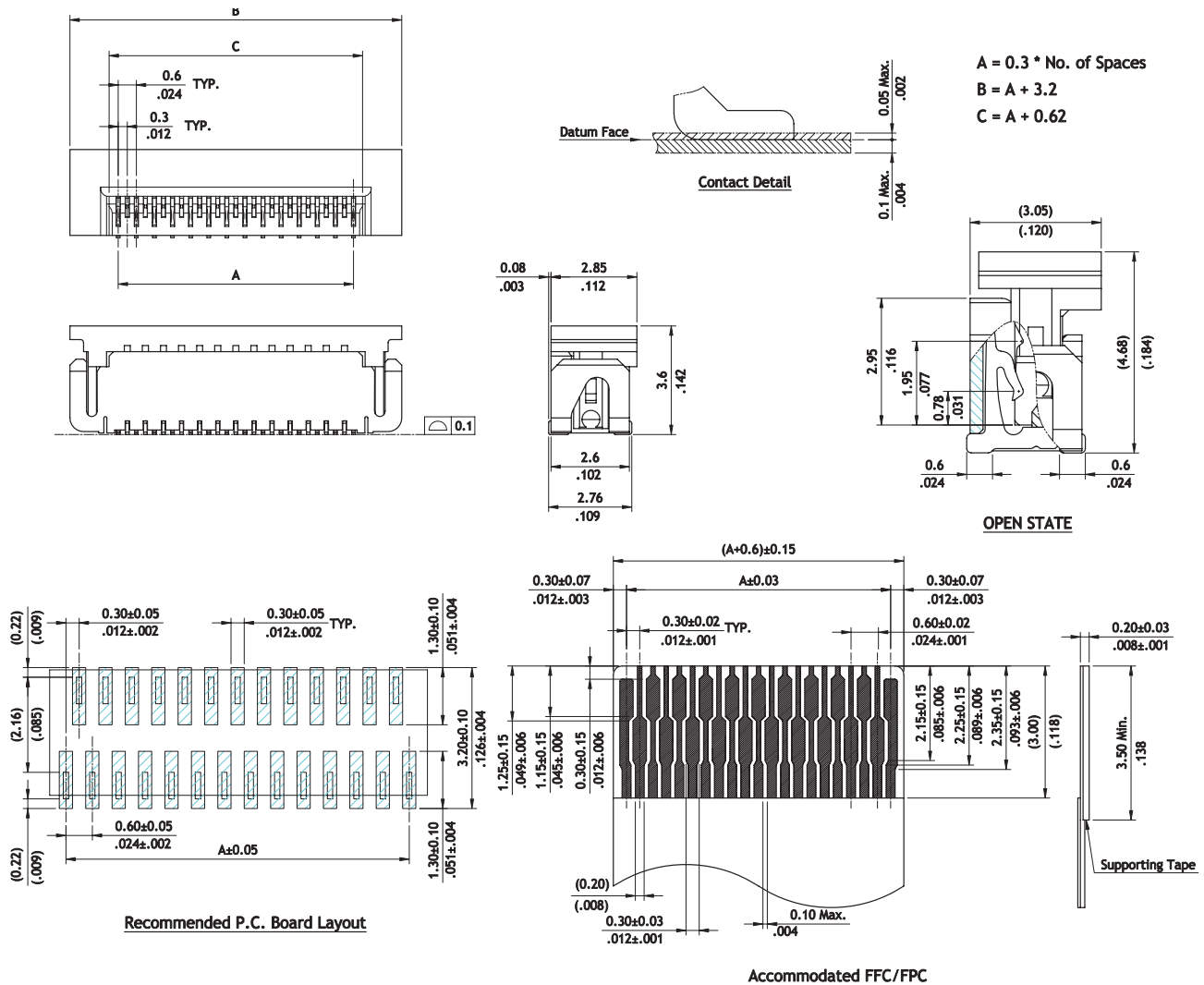

Ordering Code	①	②	③	④	⑤	⑥	⑦	⑧
	CF94	45	1	V	D	R	0	NH
① Series No.								
② No. of Circuits: 15,17,19,21,23, 25,27,29,31,33,35,37,39,41,43, 45,47,49,51								
*Circuits not found above please consult manufacturer*								
③ Plating Code:								
1 = Matte Tin over Nickel								
F = Gold flash over Nickel								
④ Contact Style:								
V = Vertical Type								
⑤ D = Double Row								
⑥ Packing: R0 = Tape & Reel								
⑦ Other Options:								
0 = Standard								
* Special options consult manufacturer								
⑧ NH = For Lead Free IR process and Halogen-Free								

FFC & FPC CONNECTOR

**CF98 Series 0.40mm(.016") H=1.20 ZIF FFC/FPC Connectors (Back Flip)**

- ⊙ 1.20mm above the board
- ⊙ FFC/FPC zero insertion force and high retention force
- ⊙ Insulator: High temperature plastic UL 94V-0, Color Nature
- ⊙ Cover: High temperature plastic UL 94V-0, Color Black
- ⊙ Designed easy for FPC installation and reliable operation
- ⊙ With metal fixed tabs to secure connector in place

**NEW**

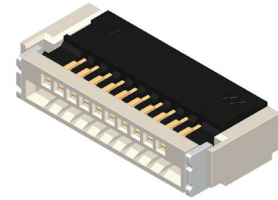

RoHS Compliant

P/N CF98\*\*\*D0R0-NH

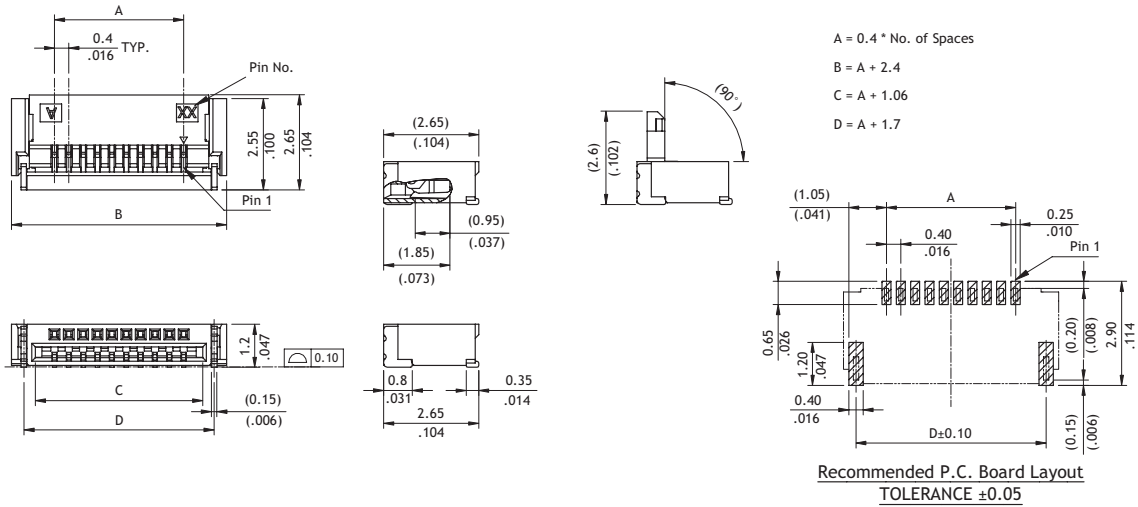

P/N CF98\*\*\*D0R0-NH

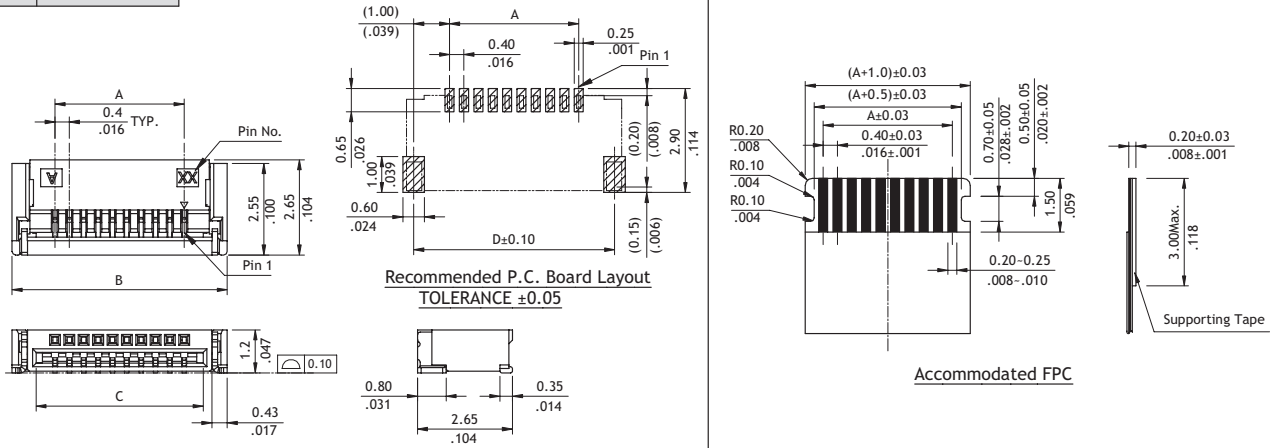

**Ordering Code**

① ② ③ ④ ⑤ ⑥ ⑦ ⑧  
**CF98 30 1 D 0 R 0 - NH**

- ① Series No.
- ② No. of Circuits: 04 ~ 30
- ③ Plating Code:  
 1 = Matte Tin over Nickel  
 F = Gold flash over Nickel
- ④ Contact style :  
 D = Downside
- ⑤ Color : 0 = Nature
- ⑥ Packing Option : R = Tape & Reel
- ⑦ Options: 0 = Standard  
 A = Larger fixed tab
- ⑧ NH = For Lead Free soldering process and Halogen-Free

**CF86 Series 0.5mm(.020") H=0.90 SMT ZIF FFC/FPC Connectors**

CF

- ⊙ 0.9mm above the board
- ⊙ Body : LCP With 30% G.F 94V-0 Color Nature
- ⊙ Contact : Copper alloy

RoHS Compliant

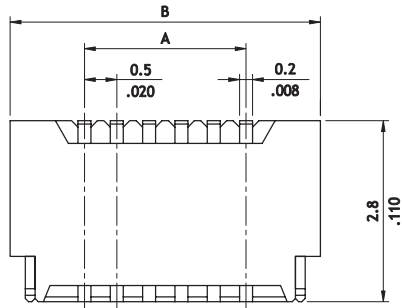
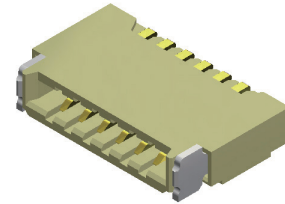

A = 0.5 x No. of Spaces  
 B = A + 2.3  
 C = A + 1.07  
 D = A + 1.68

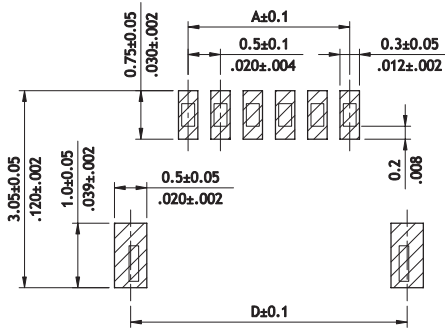
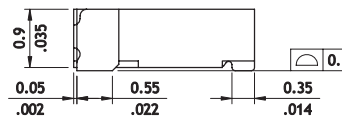
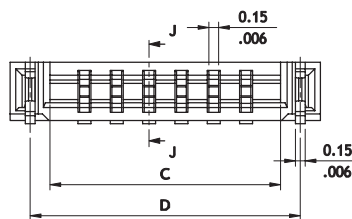
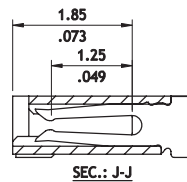

Recommended P.C Board Layout

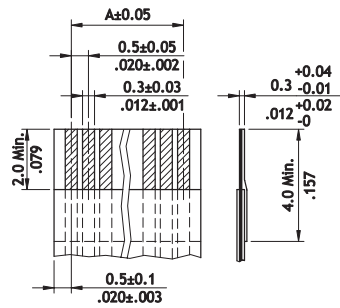

Accommodated FFC/FPC

**Ordering Code**

① ② ③ ④ ⑤ ⑥ ⑦ ⑧  
**CF86 30 2 H 0 R 0 - NH**

- ① Series No.
- ② No. of Circuits: 04 ~ 30
- ③ Plating Code:  
2 =Gold flash over Nickel plated

- ④ Contact style :  
H = Side Entry
- ⑤ Color : 0 = Nature

- ⑥ Packing Option : R = Tape & Reel
- ⑦ Options: 0 = Standard
- ⑧ NH = For Lead Free soldering process and Halogen-Free

**CF42 Series 0.50mm (.020")H=0.96 SMT ZIF FFC/FPC Connectors (Back Flip actuator)**

- ⊙ 0.96mm above the board
- ⊙ FFC/FPC zero insertion force and high retention force
- ⊙ Insulator: High temperature plastic UL 94V-0, Color Nature
- ⊙ Cover: High temperature plastic UL 94V-0, Color Black
- ⊙ Designed easy for FFC/FPC installation and reliable operation
- ⊙ With metal fixed tabs to secure connector in place

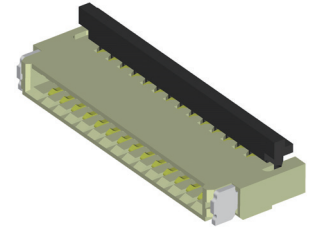

**RoHS** Compliant

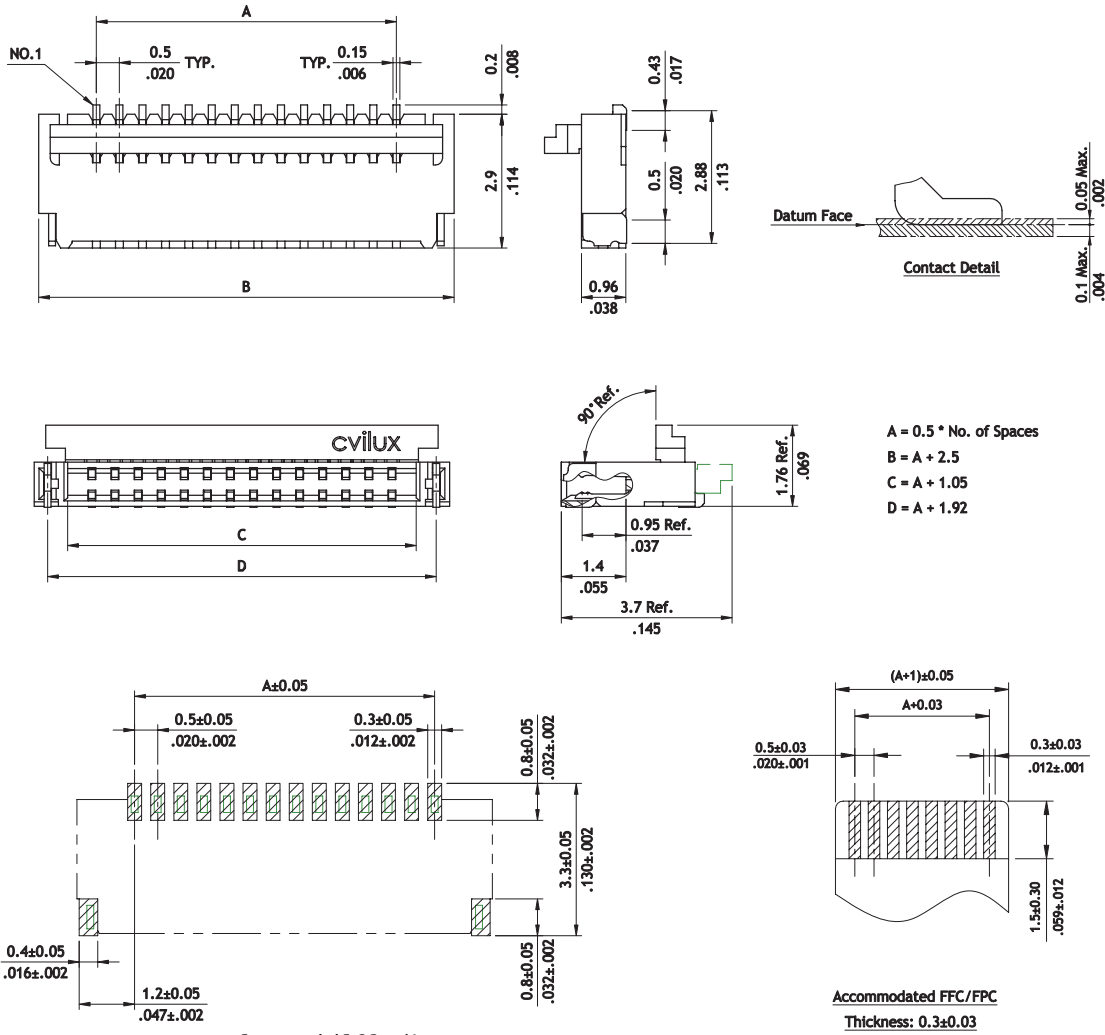

**Ordering Code**

① ② ③ ④ ⑤ ⑥ ⑦ ⑧ ⑨  
**CF42 20 F H 0 R 0 - 05 - NH**

- ① Series No.
- ② No. of Circuits: 02 ~ 50  
(Available: 2~30,34,36,40,45,50)  
\*Circuits not found above please consult manufacturer\*

- ③ Plating Code:  
1 = Matte Tin over Nickel  
F = Gold flash over Nickel
- ④ Contact Style:  
H = Dual Side
- ⑤ Color: 0 = Nature

- ⑥ Packing:  
R = Tape & Reel
- ⑦ Other Options:  
0 = Standard
- ⑧ Pitch: 05 = 0.50 mm
- ⑨ NH = For Lead Free IR process and Halogen-Free

**CF42 Series 0.50mm(.020")H=0.96 SMT ZIF FFC/FPC Connectors (Back Flip actuator)**

CF

- ⊙ 0.96mm above the board
- ⊙ FFC/FPC zero insertion force and high retention force
- ⊙ Insulator: High temperature plastic UL 94V-0, Color Nature
- ⊙ Cover: High temperature plastic UL 94V-0, Color Black
- ⊙ Designed easy for FFC/FPC installation and reliable operation
- ⊙ With metal fixed tabs to secure connector in place

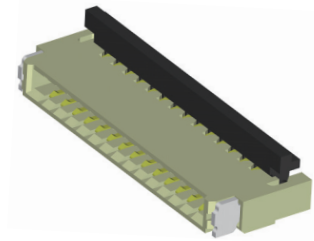

RoHS Compliant

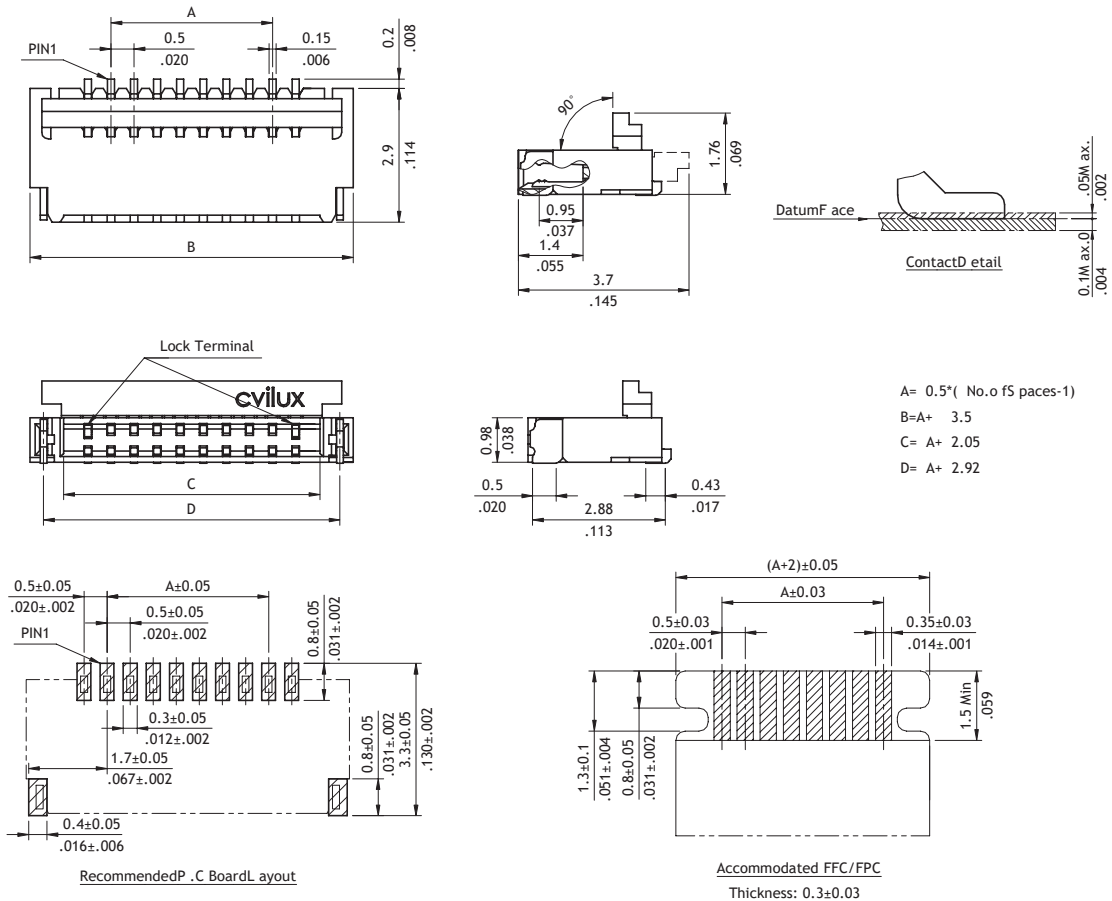

**Ordering Code**

① ② ③ ④ ⑤ ⑥ ⑦ ⑧ ⑨  
**CF42 08 F H 0 R A - 05 - NH**

- ① Series No.
- ② No. of Circuits: 04 ~ 29 (Available: 4, 6, 8, 10)  
\*Circuits not found above please consult manufacturer\*
- ③ Plating Code:  
1 = Matte Tin over Nickel  
F = Selective Gold flash over Nickel
- ④ Contact Style:  
H = Dual Side
- ⑤ Color: 0 = Nature
- ⑥ Packing : R = Tape & Reel
- ⑦ Other Options:  
A = Inner Lock Type
- ⑧ Pitch: 05 = 0.50 mm
- ⑨ NH = For Lead Free IR process and Halogen-Free

**CF35 Series 0.50mm(.020")H=0.96 SMT ZIF One-Touch FFC/FPC Connectors**

- ⊙ 0.96mm above the board
- ⊙ FFC/FPC zero insertion force and high retention force
- ⊙ Insulation: High temperature plastic UL 94V-0, Color Nature
- ⊙ Cover: High temperature plastic UL 94V-0, Color Black
- ⊙ Actuator designed easy for FFC/FPC installation and reliable operation
- ⊙ With metal fixed tabs to secure connector in place

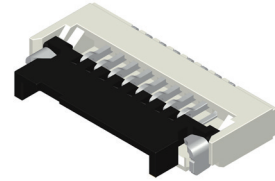

RoHS Compliant  

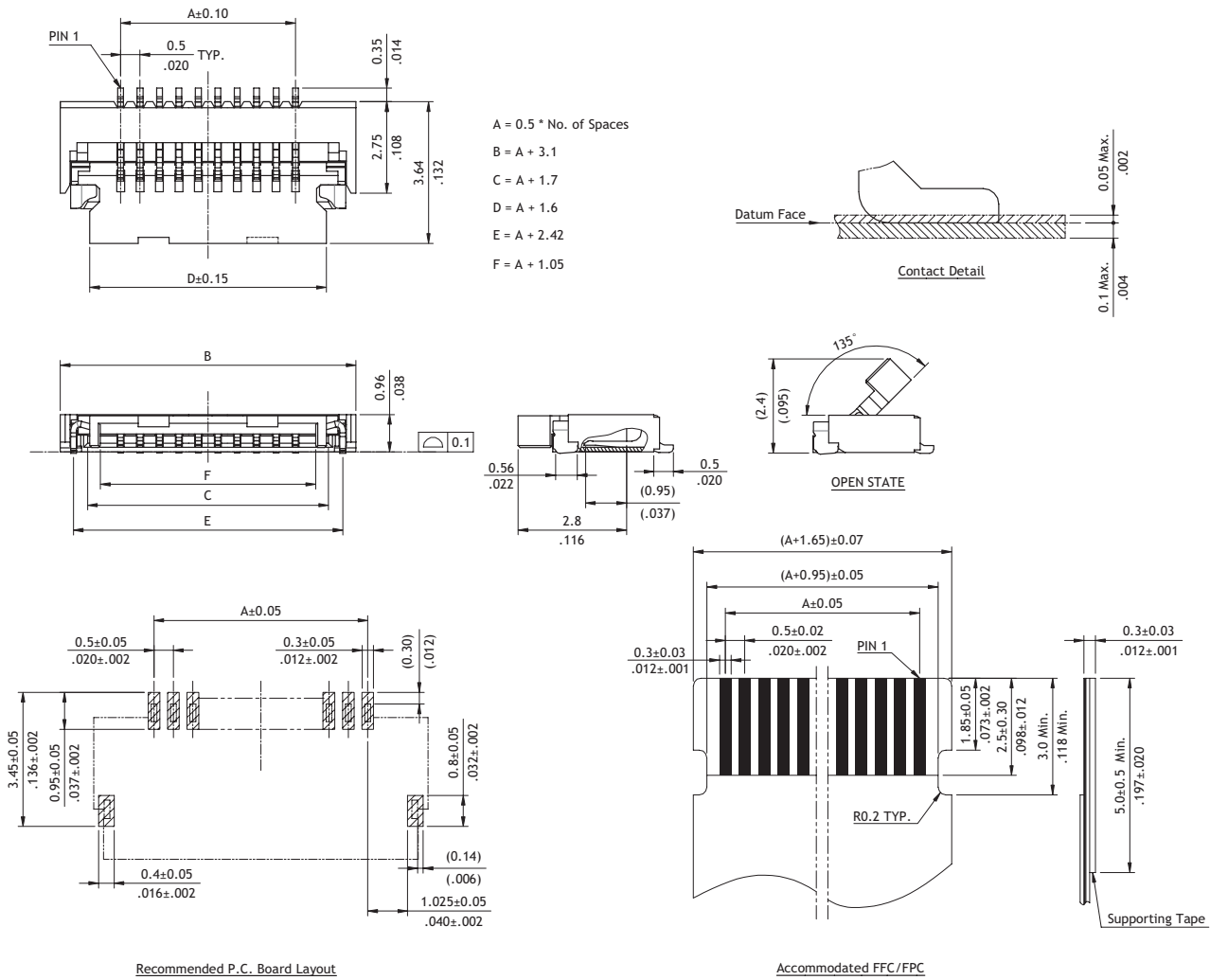

**Ordering Code**

① CF35    ② 08    ③ 2    ④ D    ⑤ 0    ⑥ RD - NH    ⑦

- ① Series No.
- ② No. of Circuits: 04 ~ 30
- ③ Plating Code:  
2 = Gold flash over Nickel

- ④ Contact Style:  
D = Downside Contact
- ⑤ Color: 0 = Nature
- ⑥ Packing : RD = Tape & Reel

⑦ NH = For Lead Free IR process and Halogen-Free

**CF35 Series 0.50mm(.020")H=0.96 SMT ZIF One-Touch FFC/FPC Connectors**

CF

- ⊙ 0.96mm above the board
- ⊙ FFC/FPC zero insertion force and high retention force
- ⊙ Insulation: High temperature plastic UL 94V-0, Color Nature
- ⊙ Cover: High temperature plastic UL 94V-0, Color Black
- ⊙ Actuator designed easy for FFC/FPC installation and reliable operation
- ⊙ With metal fixed tabs to secure connector in place

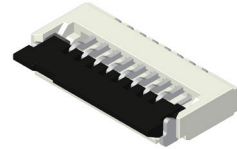

RoHS Compliant

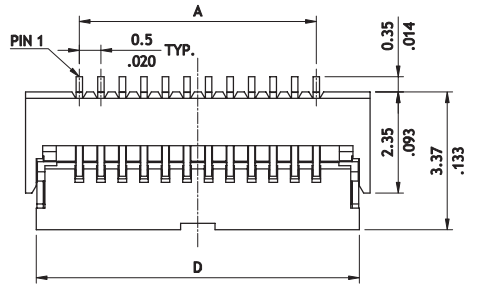

A = 0.5 \* No. of Spaces  
 B = A + 2.5  
 C = A + 1.1  
 D = A + 1.9  
 E = A + 1.82

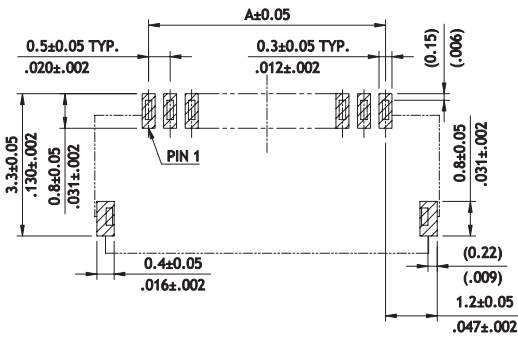
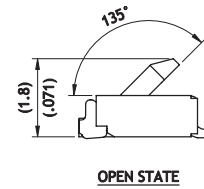
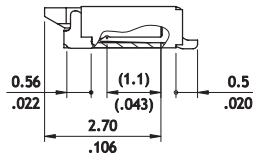
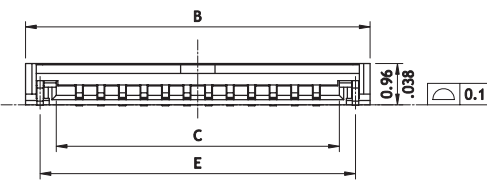
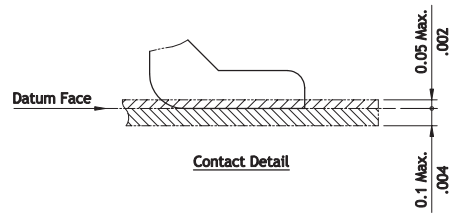

Recommended P.C. Board Layout

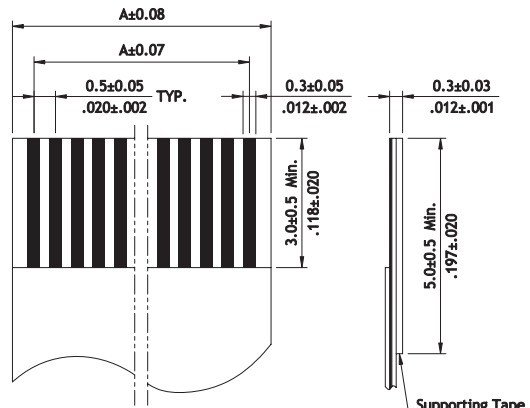

Accommodated FFC/FPC

**Ordering Code**

① ② ③ ④ ⑤ ⑥ ⑦  
**CF35 06 2 D 0 RE - NH**

- ① Series No.
- ② No. of Circuits: 04 ~ 30
- ③ Plating Code:  
2 = Gold flash over Nickel

- ④ Contact Style:  
D = Downside Contact
- ⑤ Color: 0 = Nature
- ⑥ Packing: RE = Tape & Reel

⑦ NH = For Lead Free IR process and Halogen-Free

**CF35 Series 0.50mm(.020")H=0.96 SMT ZIF One-Touch FFC/FPC Connectors**

- ⊙ 0.96mm above the board
- ⊙ FFC/FPC zero insertion force and high retention force
- ⊙ Insulation: High temperature plastic UL 94V-0, Color Nature
- ⊙ Cover: High temperature plastic UL 94V-0, Color Black
- ⊙ Actuator designed easy for FFC/FPC installation and reliable operation
- ⊙ With metal fixed tabs to secure connector in place

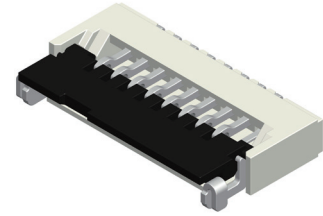

RoHS Compliant  

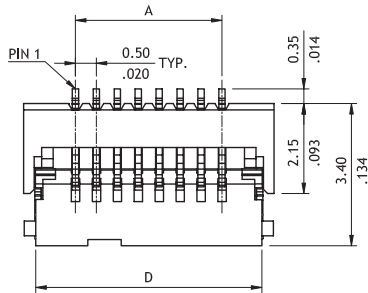

A = 0.5 \* No. of Spaces  
 B = A + 2.5  
 C = A + 1.1  
 D = A + 1.9  
 E = A + 1.80

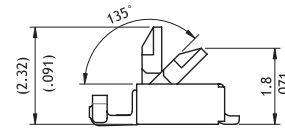
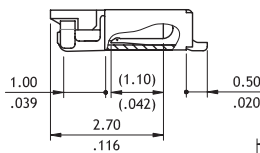
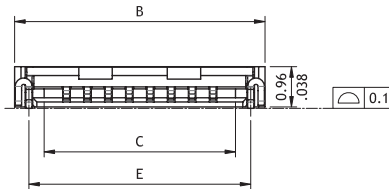
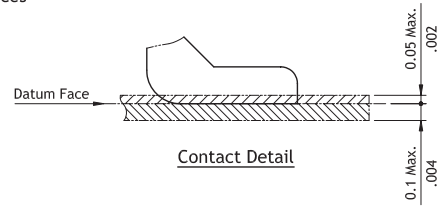

OPEN STATE

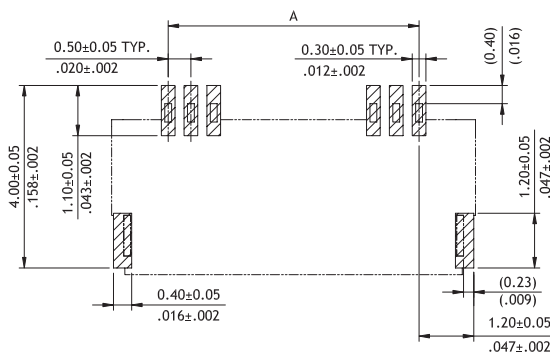

Recommended P.C. Board Layout

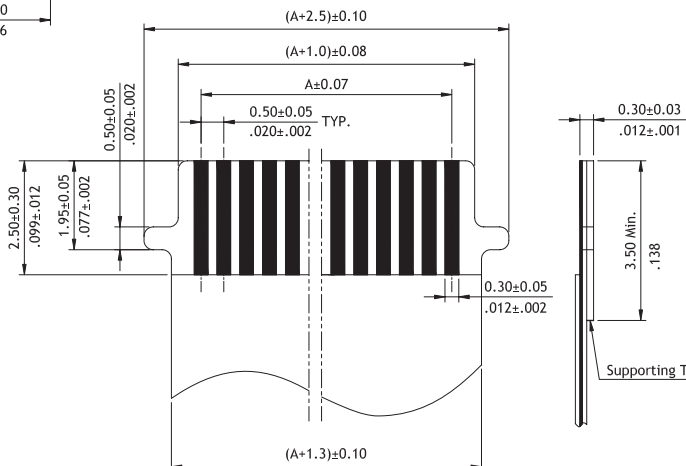

Accommodated FFC/FPC

Ordering Code

① ② ③ ④ ⑤ ⑥ ⑦  
**CF35 06 2 D 0 RM - NH**

- ① Series No.
- ② No. of Circuits: 04 ~ 30
- ③ Plating Code :  
2 = Gold flash over Nickel
- ④ Contact Style:  
D = Downside Contact
- ⑤ Color: 0 = Nature
- ⑥ Packing : RM = Tape & Reel
- ⑦ NH = For Lead Free IR process and Halogen-Free

**CF87 Series 0.5mm(.020") H=0.98 SMT ZIF FFC/FPC Connectors (Back Flip actuator)**

CF

- ⊙ 0.98mm above the board
- ⊙ FFC/FPC zero insertion force and high retention force
- ⊙ Insulator: High temperature plastic UL 94V-0, Color Nature
- ⊙ Cover : High temperature plastic UL 94V-0, Color Black
- ⊙ Actuator designed easy for FPC installation and reliable operation
- ⊙ With metal fixed tabs to secure connector in place

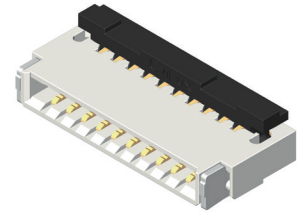

RoHS Compliant

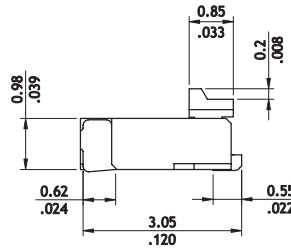
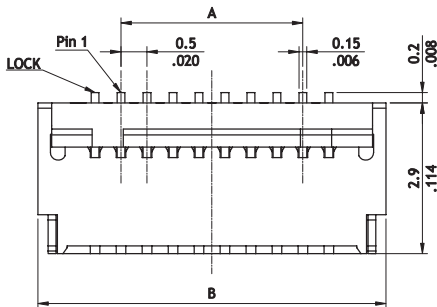

A = 0.5 \* No. of Spaces  
 B = A + 3.2  
 C = A + 2.05  
 D = A + 2.65

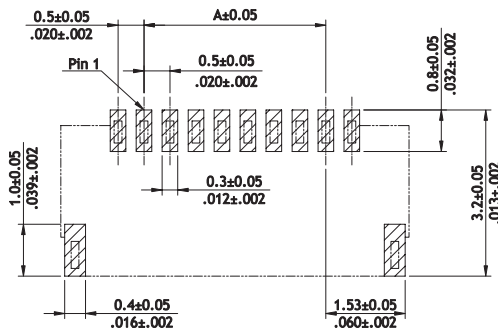
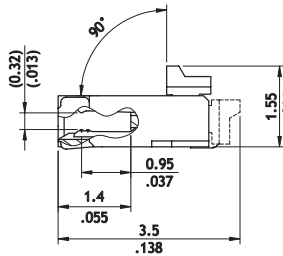
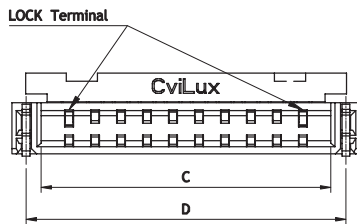

Recommended P.C. Board Layout

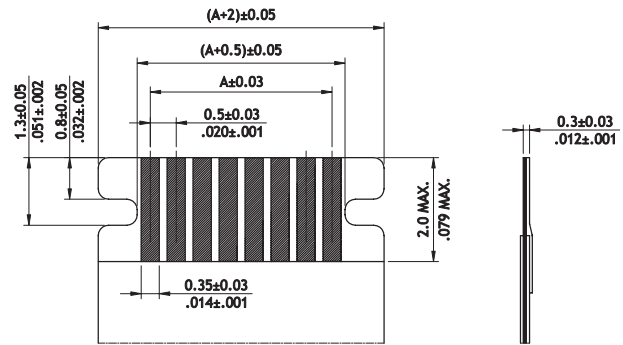

Accommodated FFC/FPC

**Ordering Code**

① ② ③ ④ ⑤ ⑥ ⑦ ⑧ ⑨  
**CF87 30 1 H 0 R 0 - 05 - NH**

- |  |   |  |
|--|---|--|
| <ul style="list-style-type: none"> <li>① Series No.</li> <li>② No. of Circuits: 04 ~ 30</li> <li>③ Plating Code:<br/>1 = Matte Tin over Nickel<br/>F = Gold flash over Nickel</li> </ul> | <ul style="list-style-type: none"> <li>④ Contact style :<br/>H = Dual Side</li> <li>⑤ Color : 0 = Nature</li> <li>⑥ Packing Option :<br/>R = Tape &amp; Reel</li> </ul> | <ul style="list-style-type: none"> <li>⑦ Options: 0 = Standard</li> <li>⑧ Pitch : 05=0.5mm</li> <li>⑨ NH = For Lead Free soldering process and Halogen-Free</li> </ul> |
|--|---|--|

**CF92 Series 0.50mm(.020") H=1.22 SMT ZIF Automatic FFC/FPC Connectors**

- ⊙ 1.22mm above the board
- ⊙ Insulator: High temperature plastic UL 94V-0, Color Nature
- ⊙ Cover : High temperature plastic UL 94V-0, Color Black
- ⊙ Actuator designed easy for FPC installation and reliable operation
- ⊙ With metal fixed tabs to secure connector in place

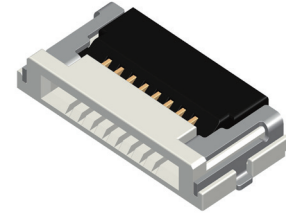

RoHS Compliant  

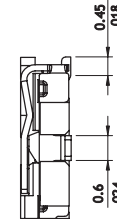
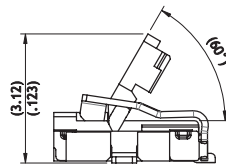
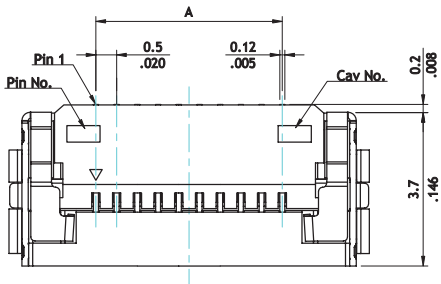

OPEN STATE

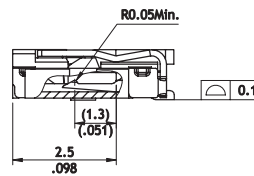
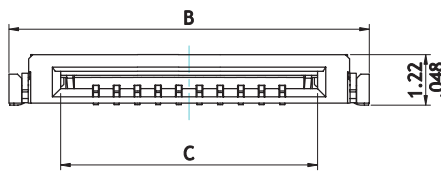

$A = (N - 1) \times 0.5$   
 $B = A + 4.2$   
 $C = A + 1.7$

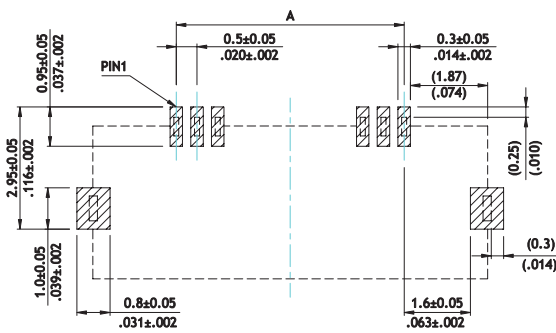

Recommended P.C. Board Layout

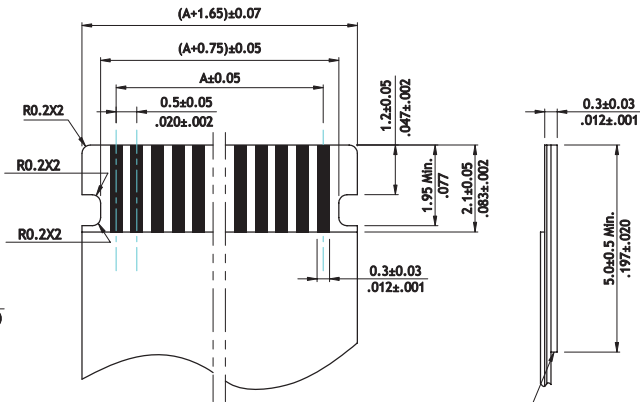

Accommodated FFC/FPC

Supporting Tape

**Ordering Code**

① ② ③ ④ ⑤ ⑥ ⑧ ⑨  
**CF92 40 1 D 0 R0 - 05 - NH**

- ① Series No.
- ② No. of Circuits: 4 , 40
- ③ Plating Code:  
 1 = Matte Tin over Nickel  
 F = Gold flash over Nickel

- ④ Contact style :  
 D = Downside Contact
- ⑤ Color : 0 = Nature

- ⑥ Packing : R0 = Tape & Reel
- ⑦ 05 = Pitch 0.50mm
- ⑧ NH = For Lead Free soldering process and Halogen-Free

**CF55 Series 0.50mm(.020")H=1.25 SMT ZIF FFC/FPC Connectors**

CF

- ⊙ 1.25mm above the board
- ⊙ FFC/FPC zero insertion force and high holding force
- ⊙ Insulation: High temperature plastic UL 94V-0, Color Nature
- ⊙ Cover: High temperature plastic UL 94V-0, Color Black
- ⊙ Actuator designed easy for FFC/FPC installation and reliable operation
- ⊙ With metal fixed tabs to secure connector in place

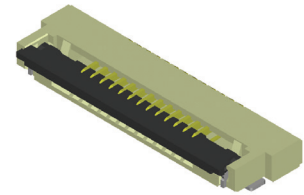

RoHS Compliant

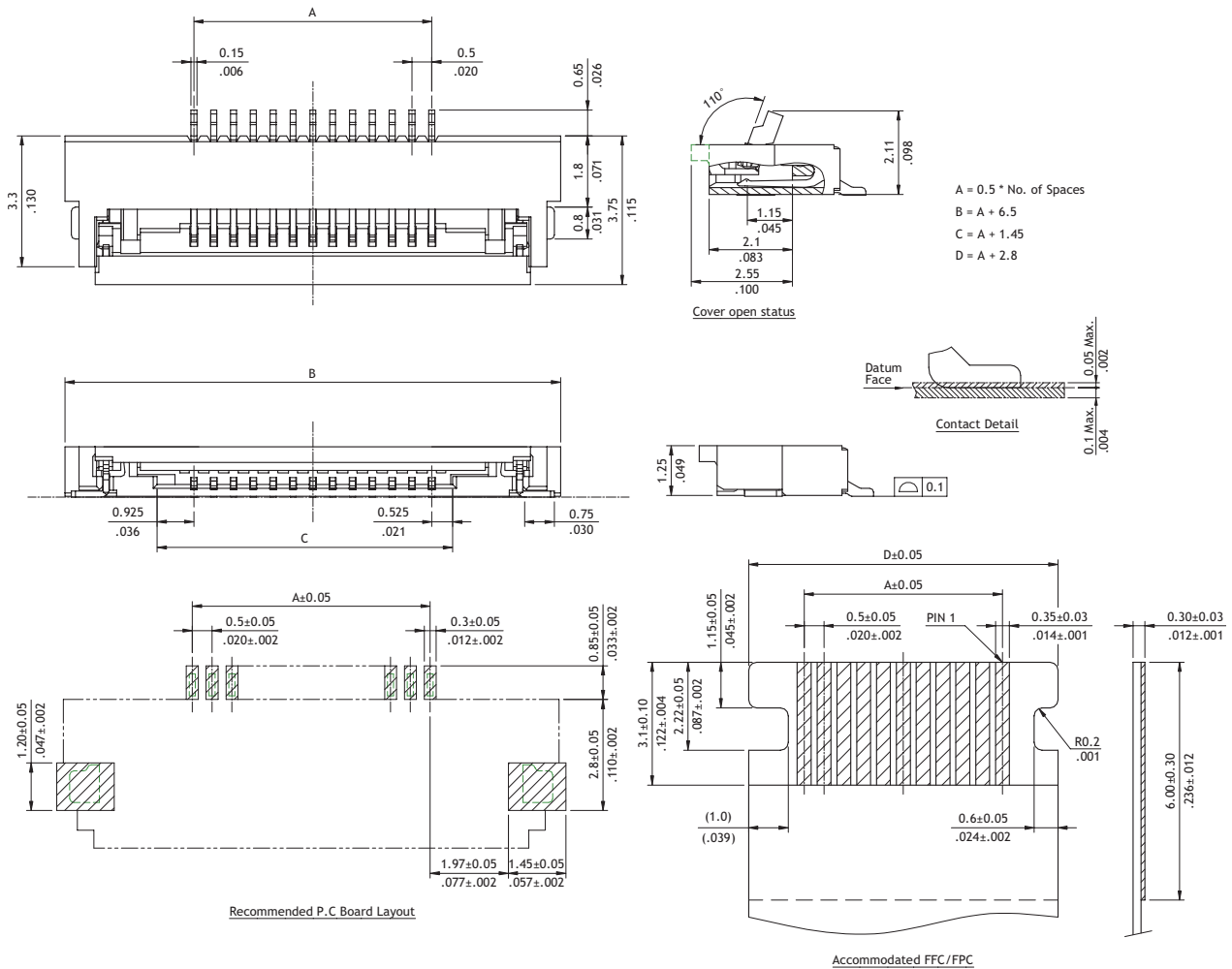

**Ordering Code**

① ② ③ ④ ⑤ ⑥ ⑦ ⑧ ⑨  
**CF55 12 F D 0 R A - 05 - NH**

- ① Series No.
- ② No. of Circuits: 6-40 (Available: 6,12)  
 \*Circuits not found above please consult manufacturer\*
- ③ Plating Code:  
 F = Selective Gold flash over Nickel
- ④ Contact Style:  
 D = Downside Contact
- ⑤ Color: 0 = Nature
- ⑥ Packing : R = Tape & Reel
- ⑦ Other Options:  
 A = Without Mylar
- ⑧ Pitch : 05 = 0.50mm
- ⑨ NH = For Lead Free IR process and Halogen-Free

**CF88 Series 0.5mm(.020") H=1.57 SMT ZIF FFC/FPC Connectors (Back Flip actuator)**

- ⊙ 1.57mm above the board
- ⊙ FFC/FPC zero insertion force and high retention force
- ⊙ Insulator: High temperature plastic UL 94V-0, Color Nature
- ⊙ Cover : High temperature plastic UL 94V-0, Color Black
- ⊙ Actuator designed easy for FPC installation and reliable operation
- ⊙ With metal fixed tabs to secure connector in place

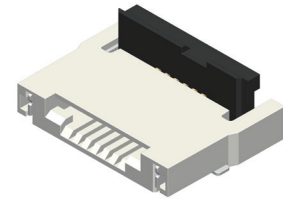

RoHS Compliant  

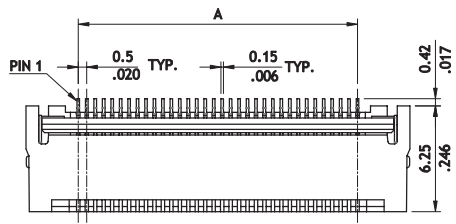

A = 0.5 \* No. of Spaces  
 B = A + 6.2  
 C = A + 2.75  
 D = A + 1.1

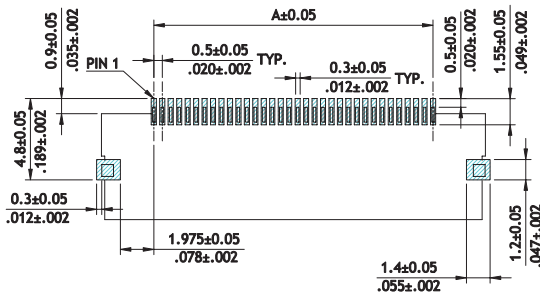
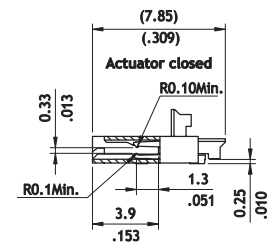
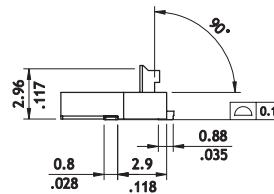
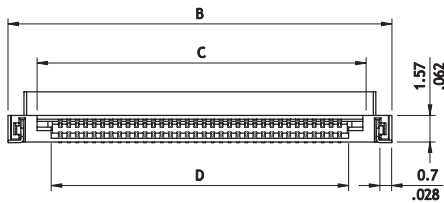
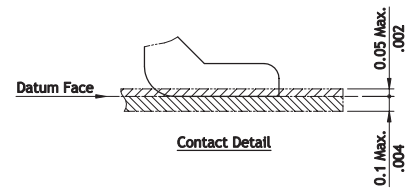

Recommended P.C. Board Layout

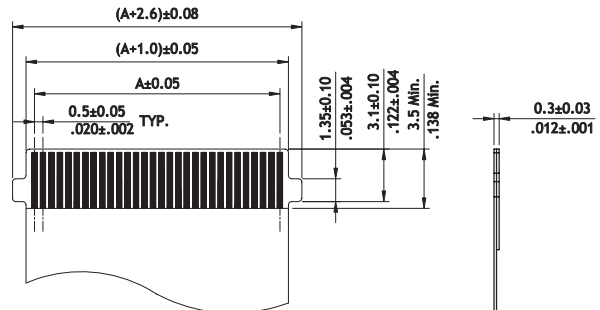

Accommodated FFC/FPC

**Ordering Code**

① ② ③ ④ ⑤ ⑥ ⑦ ⑧  
**CF88 30 1 H 0 R0 - 05 - NH**

- ① Series No.
- ② No. of Circuits: 04 ~ 30
- ③ Plating Code:  
 1 = Matte Tin over Nickel  
 F = Gold flash over Nickel
- ④ Contact style : H = Dual Side
- ⑤ Color : 0 = Nature
- ⑥ Packing Option :  
 RD = Tape & Reel
- ⑦ Pitch : 05=0.5mm
- ⑧ NH = For Lead Free soldering process and Halogen-Free

**CF69 Series 0.50mm(.020") H=1.75 SMT LIF One-Touch FFC/FPC Connectors**

CF

- ⊙ 1.75mm above the board
- ⊙ FFC/FPC low insertion force and high retention force
- ⊙ Insulator: High temperature plastic UL 94V-0, Color Nature
- ⊙ Cover: High temperature plastic UL 94V-0, Color Black
- ⊙ Actuator designed easy for FPC installation and reliable operation
- ⊙ With metal fixed tabs to secure connector in place

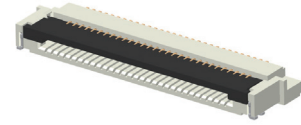

RoHS Compliant

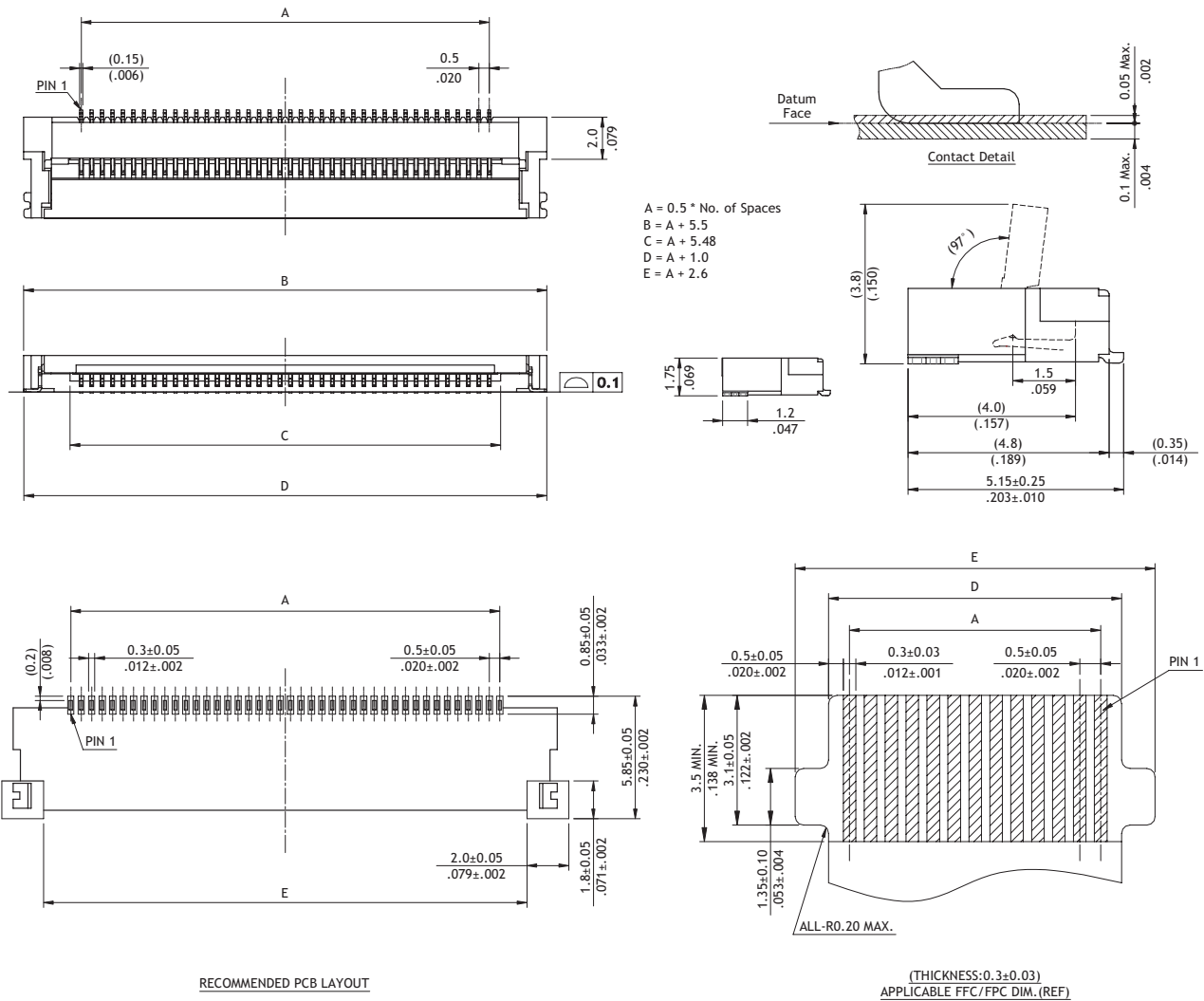

**Ordering Code**

① ② ③ ④ ⑤ ⑥ ⑦ ⑧ ⑨  
**CF69 50 2 D 0 R 0 - 05 - NH**

- ① Series No.
- ② No. of Circuits: 40 , 44 , 50  
\*Circuits not found above please consult manufacturer\*
- ③ Plating Code:  
1 = Matte Tin over Nickel  
2 = Gold flash over Nickel
- ④ Contact Style:  
D= Downside Contact
- ⑤ Color: 0 = Nature
- ⑥ Packing: R = Tape & Reel  
T = Tube Packing
- ⑦ Other Options: 0 = Standard  
\*Special option consult manufacturer
- ⑧ Pitch: 05= 0.50 mm
- ⑨ NH = For Lead Free IR process and Halogen-Free

**CF39 Series 0.50mm(.020") SMT One - Touch FFC/FPC Connectors**

- ⊙ 1.00mm above the board
- ⊙ Insulator: High temperature plastic UL 94V-0, Color Nature
- ⊙ Cover : High temperature plastic UL 94V-0, Color Black
- ⊙ Actuator designed easy for FPC installation and reliable operation
- ⊙ With metal fixed tabs to secure connector in place

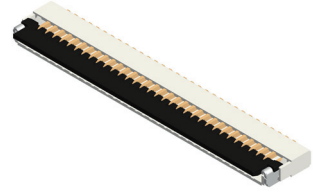

RoHS Compliant  

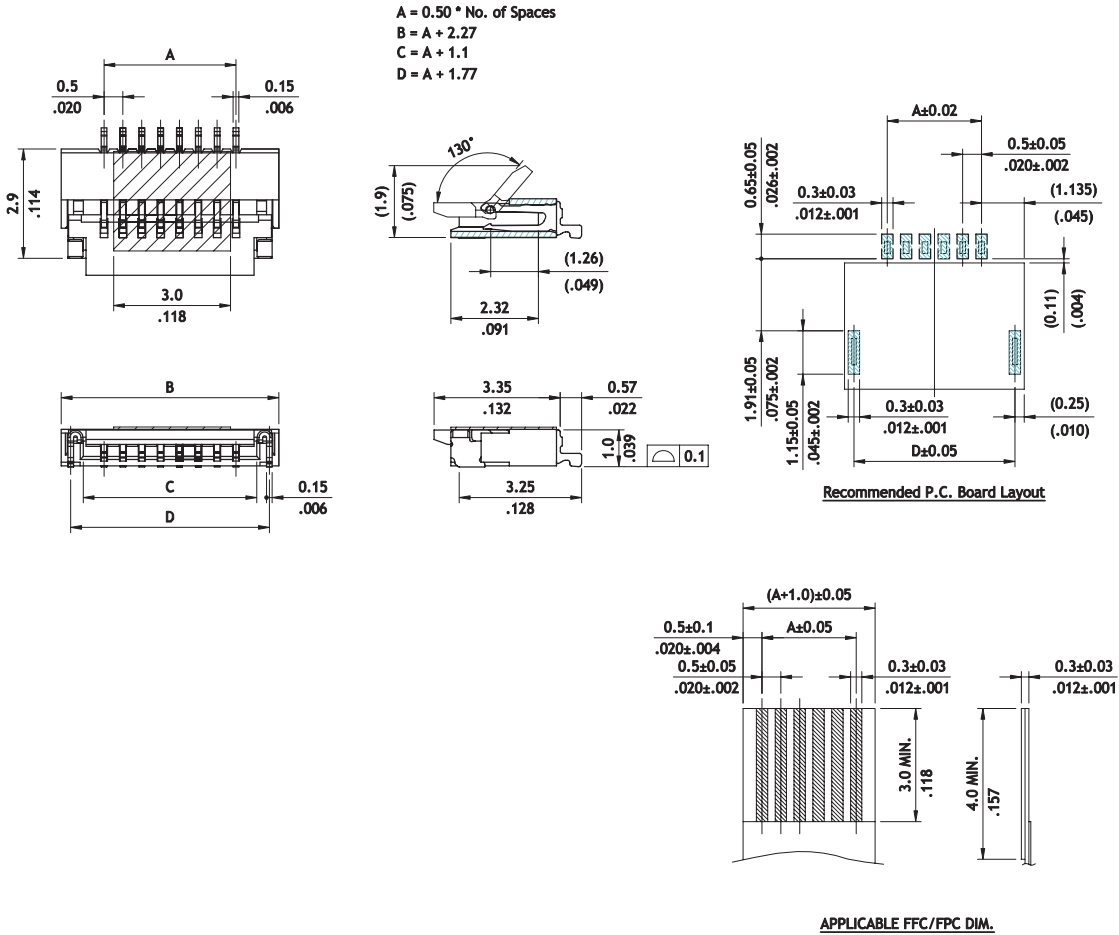

**Ordering Code**

① ② ③ ④ ⑤ ⑥ ⑦  
**CF39 40 2 D 0 R0 - NH**

- |   |  |   |
|---|--|---|
| <p>① Series No.</p> <p>② No. of Circuits:<br/>                 04 ,06,08,10,12,15,16, 18,<br/>                 20, 22, 24, 28, 30, 32, 40</p> | <p>③ Plating Code:<br/>                 2 =Gold flash over Nickel</p> <p>④ Contact style :<br/>                 D = Downside contact</p> <p>⑤ 0 = Color Nature</p> | <p>⑥ Packing:<br/>                 R0 = Tape &amp; Reel (Without Mylar)<br/>                 RM = Tape &amp; Reel(With Mylar)</p> <p>⑦ NH = For Lead Free soldering<br/>                 process and Halogen-Free</p> |
|---|--|---|

**CF75 Series 0.50mm(.020") SMT One-Touch FFC/FPC Connectors**

CF

- ⊙ 1.78mm above the board
- ⊙ Insulator: High temperature plastic UL 94V-0, Color Nature
- ⊙ Cover : High temperature plastic UL 94V-0, Color Black
- ⊙ Actuator designed easy for FPC installation and reliable operation
- ⊙ With metal fixed tabs to secure connector in place

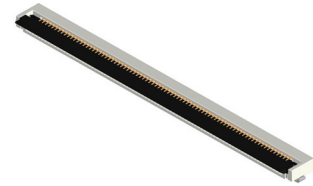

RoHS Compliant

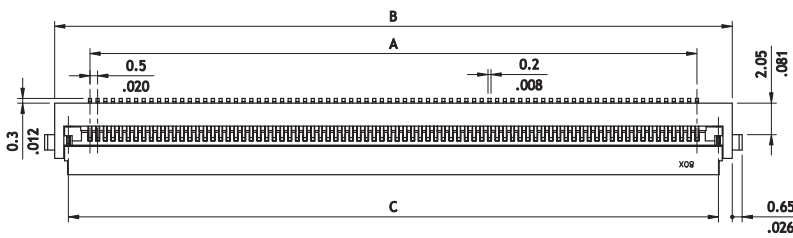

Circuits	Dimension			
	A	B	C	D
60	29.5(1.161)	34.10(1.342)	32.3(1.272)	30.60(1.205)
80	39.5(1.555)	44.10(1.736)	42.3(1.665)	40.60(1.598)

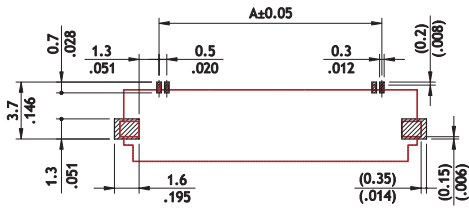
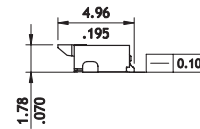
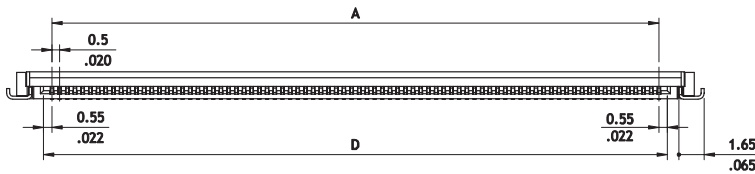

Recommended P.C. Board Layout

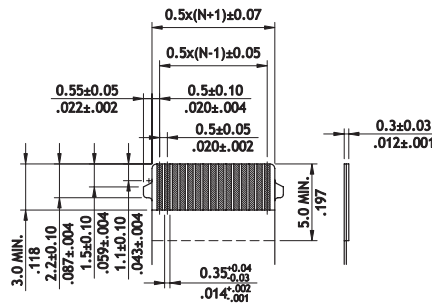

RECOMMENDED FPC DIM.  
THICKNESS:0.3±0.03

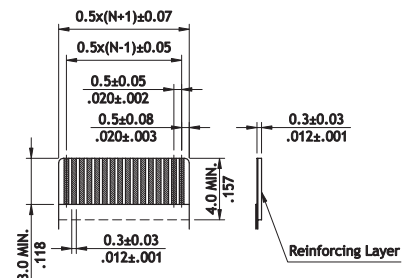

RECOMMENDED FFC DIM  
THICKNESS:0.3±0.03

**Ordering Code**

① ② ③ ④ ⑤ ⑥ ⑦  
**CF75 80 2 D 0 R0 - NH**

- ① Series No.
- ② No. of Circuits: 60 , 80
- ③ Plating Code:  
2 =Gold flash over Nickel

- ④ Contact style :  
D = Downside contact
- ⑤ Color : 0 = Nature

- ⑥ Packing : R0 = Tape & Reel
- ⑦ NH = For Lead Free soldering process and Halogen-Free

**CF82 Series 0.50mm(.020") H=2.00 SMT ZIF One-Touch FFC/FPC Connectors**

- ⊙ 2.00mm above the board
- ⊙ FFC/FPC zero insertion force and high retention force
- ⊙ Insulator: High temperature plastic UL 94V-0, Color Nature
- ⊙ Cover : High temperature plastic UL 94V-0, Color Black
- ⊙ With metal fixed tabs to secure connector in place

RoHS Compliant 

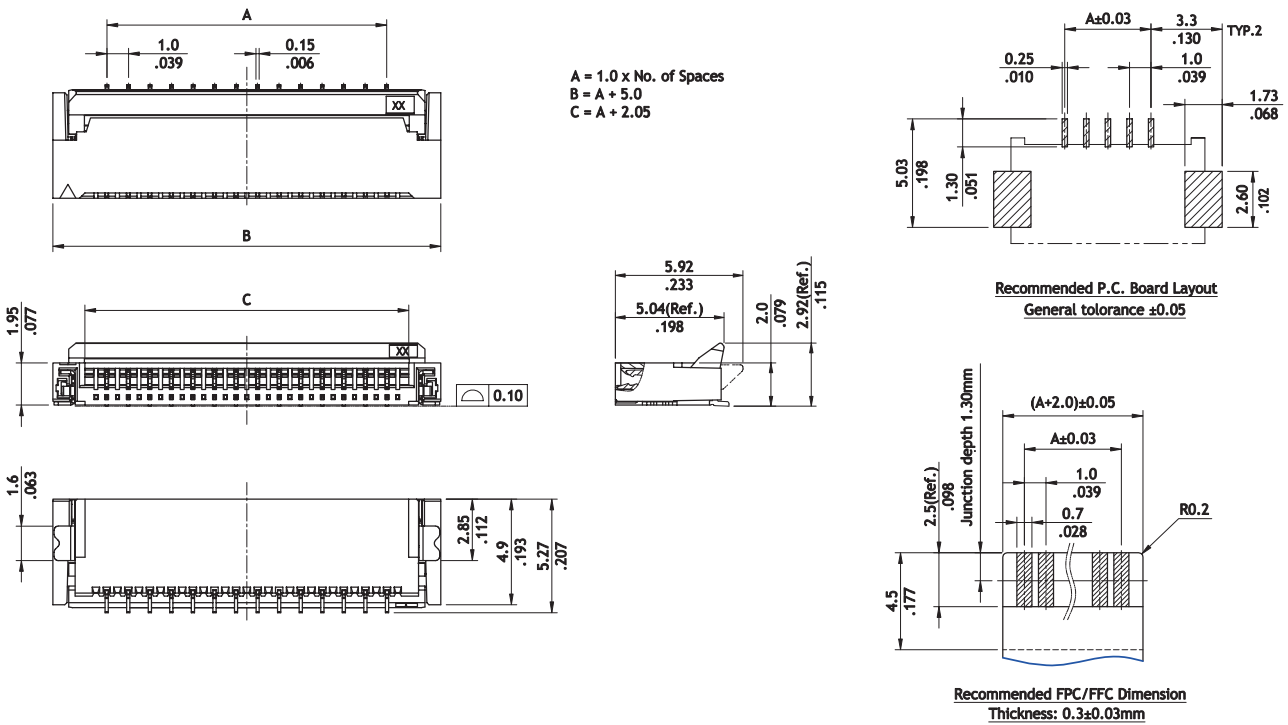
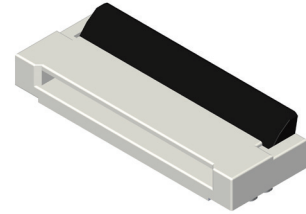

**Ordering Code**

① ② ③ ④ ⑤ ⑥ ⑦ ⑧  
**CF82 60 2 H 0 R0 - 05 - NH**

- |   |   |   |
|---|---|---|
| <p>① Series No.<br/>                 ② No. of Circuits:<br/>                 4,5,6,8,9,10,12~16,18,20,24,25,<br/>                 28,30,32,34,36,40,45,50,54,60<br/>                 ③ Plating Code:<br/>                 2 =Gold flash over Nickel</p> | <p>④ Contact style :<br/>                 H = Dual side contact<br/>                 ⑤ Color : 0 = Nature</p> | <p>⑥ Packing : R0 = Tape &amp; Reel<br/>                 ⑦ 05 = Pitch 0.5mm<br/>                 ⑧ NH = For Lead Free soldering<br/>                 process and Halogen-Free</p> |
|---|---|---|

**CF82 Series 1.00mm(.039") H=2.00 SMT ZIF One-Touch FFC/FPC Connectors**

CF

- ⊙ 2.00mm above the board
- ⊙ FFC/FPC zero insertion force and high retention force
- ⊙ Insulator: High temperature plastic UL 94V-0, Color Nature
- ⊙ Cover : High temperature plastic UL 94V-0, Color Black
- ⊙ With metal fixed tabs to secure connector in place

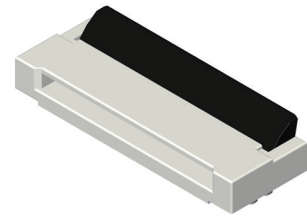

RoHS Compliant

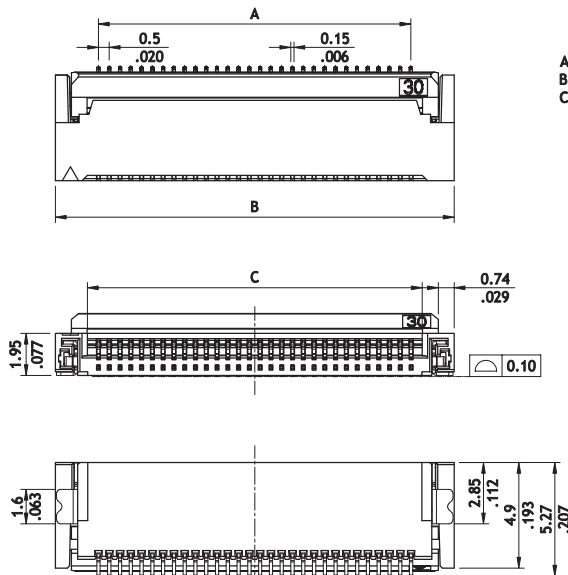

A = 0.50 x No. of Spaces  
 B = A + 4.0  
 C = A + 1.05

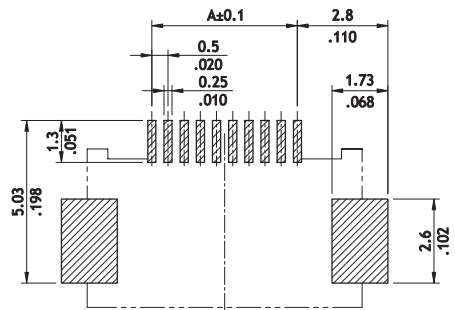
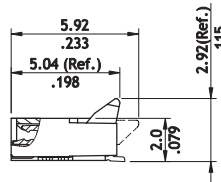

Recommended P.C. Board Layout  
 General tolerance ±0.05

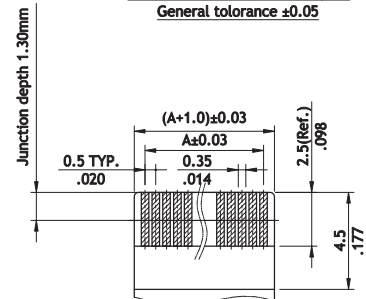

Recommended FPC/FFC Dimension  
 Thickness: 0.3±0.03mm

Ordering Code		①	②	③	④	⑤	⑥	⑦	⑧
		CF82	04	2	H	0	R0	10	NH
① Series No.	④ Contact style :	⑥ Packing : R0 = Tape & Reel		⑦ 10 = Pitch 1.00mm		⑧ NH = For Lead Free soldering process and Halogen-Free			
② No. of Circuits: 4,6,8,9,12,20,22	H = Dual side contact								
③ Plating Code: 2 =Gold flash over Nickel	⑤ Color : 0 = Nature								

FFC & FPC CONNECTOR

**CF76 Series 0.50mm(.020") H=2.10 SMT LIF FFC/FPC Connectors**

- ⊙ 2.1mm above the board
- ⊙ Copper alloy dual contacts
- ⊙ Insulation: High temperature plastic UL94V-0 , Color Nature
- ⊙ with metal fixed tabs to secure connector in place

RoHS Compliant

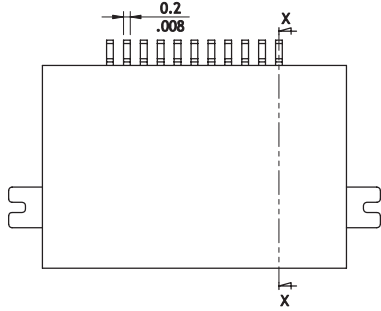
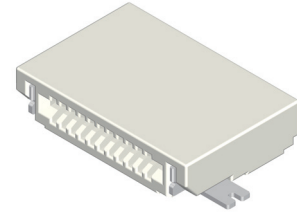

DIM. A = 0.5 x No. of Spaces  
 DIM. B = DIM. A + 4.0  
 DIM. C = DIM. A + 1.1  
 \*Available in 10 through 50 circuits

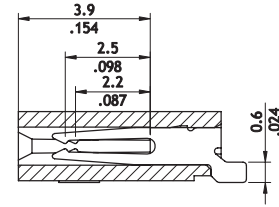
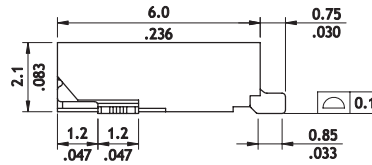
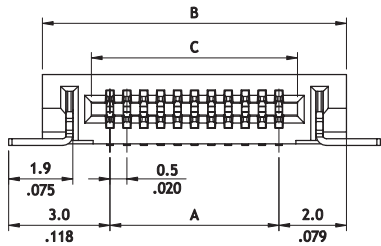

SEC.: X-X

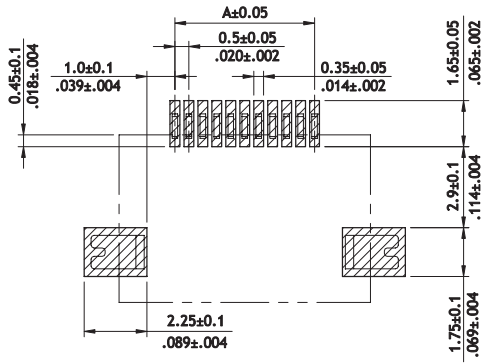

Recommended P.C.B Layout

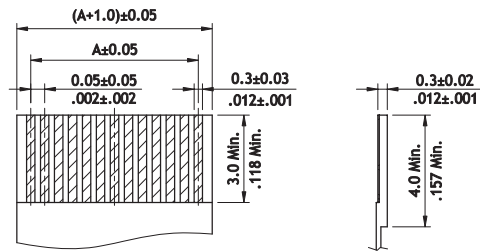

Accommodated FFC/FPC

**Ordering Code**

① ② ③ ④ ⑤ ⑥ ⑦ ⑧ ⑨  
**CF76 50 M 2 H R 0 - 05 - NH**

- ① Series No.
- ② No. of Circuits: 10 ~ 50
- ③ Contact Style: M= SMT Type
- ④ Plating: 2=Gold flash over 50u" min Nickel
- ⑤ Type : H = Side Entry
- ⑥ Packing : R = Tape & Reel
- ⑦ Other Options: 0 = Standard
- ⑧ Pitch: 05 = 0.50 mm
- ⑨ NH = For Lead Free IR process and Halogen-Free

CF85 Series 0.50mm(.020") H=2.20 SMT ZIF One-Touch FFC/FPC Connectors

CF

- ⊙ 2.20mm above the board
- ⊙ Insulator: High temperature plastic UL 94V-0, Color Nature
- ⊙ Cover : High temperature plastic UL 94V-0, Color Black
- ⊙ With metal fixed tabs to secure connector in place



RoHS Compliant  

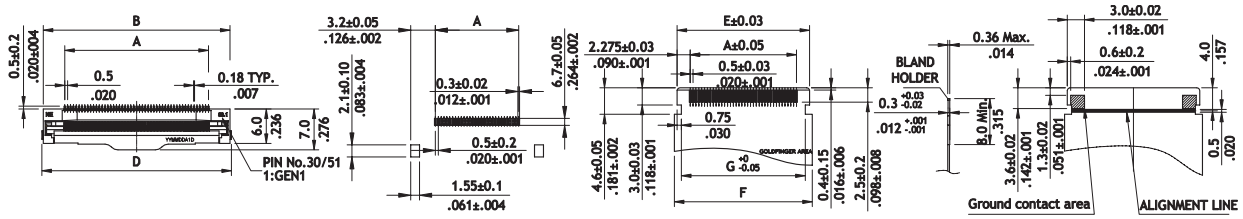

Recommended P.C. Board Layout (FOR 30/51)

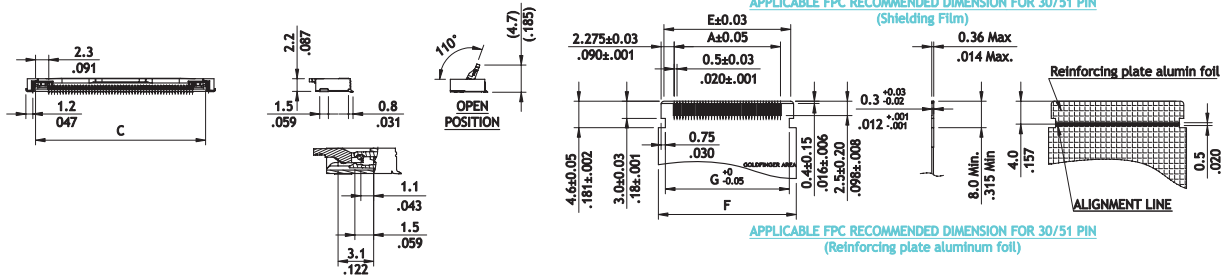

APPLICABLE FPC RECOMMENDED DIMENSION FOR 30/51 PIN (Shielding Film)

APPLICABLE FPC RECOMMENDED DIMENSION FOR 30/51 PIN (Reinforcing plate aluminum foil)

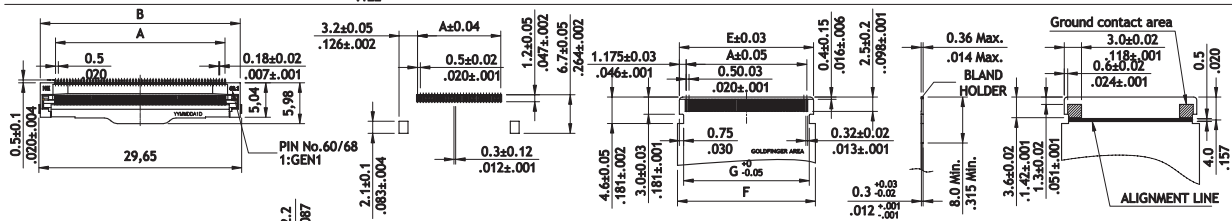

Recommended P.C. Board Layout (FOR 60/68)

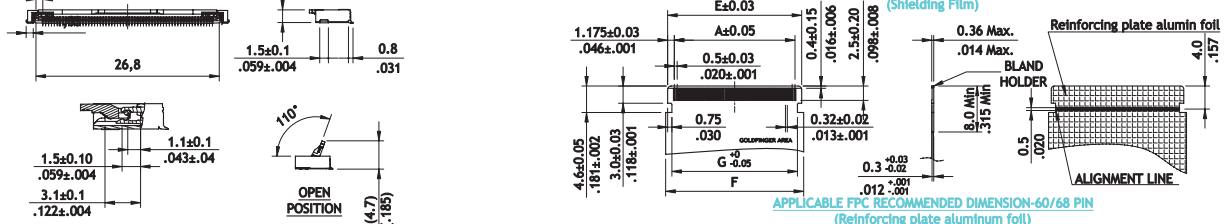

APPLICABLE FPC RECOMMENDED DIMENSION FOR 60/68 PIN (Shielding Film)

APPLICABLE FPC RECOMMENDED DIMENSION-60/68 PIN (Reinforcing plate aluminum foil)

Circuits	Dimension							Circuits	Dimension						
	A	B	C	D	E	F	G		A	B	C	D	E	F	G
60	29.5(1.161)	34.8(1.370)	31.9(1.256)	35.3(1.390)	31.85(1.254)	32.5(1.280)	30.35(1.195)	30	14.5(.571)	22.0(.866)	19.1(.752)	22.5(.886)	19.05(.750)	19.5(.768)	17.55(.691)
68	33.5(1.319)	38.8(1.528)	35.9(1.413)	39.3(1.547)	35.85(1.411)	36.5(1.437)	34.35(1.352)	51	25.0(.984)	32.5(1.280)	29.60(1.165)	33.0(1.299)	29.55(1.163)	30.0(1.181)	28.05(1.104)

Ordering Code

① ② ③ ④ ⑤ ⑥ ⑦ ⑧  
**CF85 60 A D 0 R0 - 05 - NH**

- ① Series No.
- ② No. of Circuits: 51 , 60 , 68
- ③ Plating Code:  
A = Selective Gold flash over Nickel

- ④ Contact style :  
D = Down side
- ⑤ Color : 0 = Nature

- ⑥ Packing : R0 = Tape & Reel
- ⑦ 05 = Pitch 0.50mm
- ⑧ NH = For Lead Free soldering process and Halogen-Free

**CF90 Series 0.5mm(.020") H=2.20 SMT ZIF One-Touch FFC/FPC Connectors**

- ⊙ 2.20mm above the board
- ⊙ FFC/FPC zero insertion force and high retention force
- ⊙ Insulator: High temperature plastic UL 94V-0, Color Nature
- ⊙ Cover : High temperature plastic UL 94V-0, Color Black
- ⊙ Actuator designed easy for FPC installation and reliable operation
- ⊙ With metal fixed tabs to secure connector in place

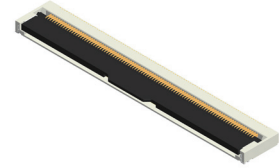

RoHS Compliant  

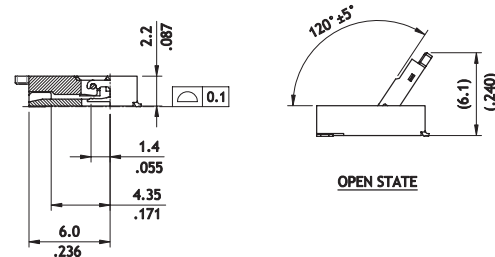
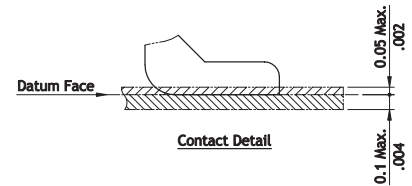
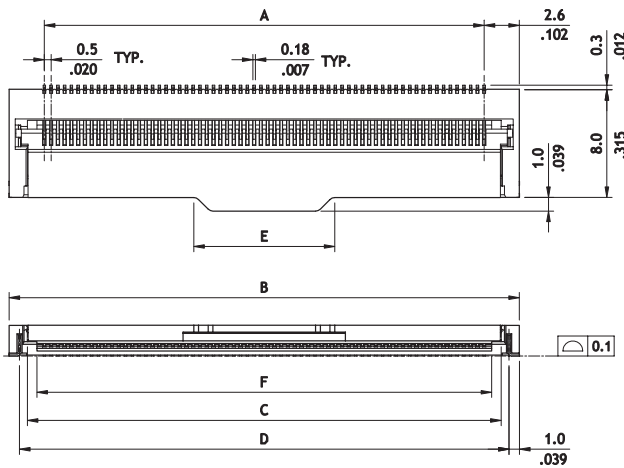

Circuits	Dimension					
	A	B	C	D	E	F
96	47.5(1.870)	52.7(2.075)	50.0(1.969)	51.2(2.016)	10.0(.394)	48.6(1.913)

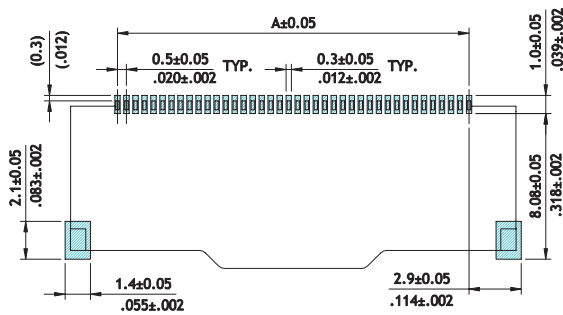

Recommended P.C. Board Layout

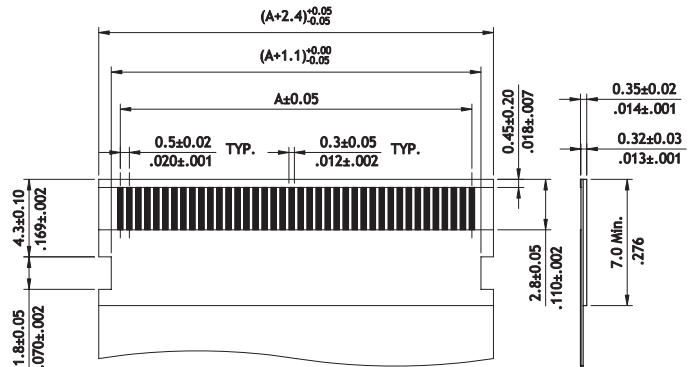

Accommodated FFC/FPC

**Ordering Code**

① ② ③ ④ ⑤ ⑥ ⑦ ⑧  
**CF90 96 1 D 0 R0 - 05 - NH**

- ① Series No.
- ② No. of Circuits: 96
- ③ Plating Code:  
1 = Matte Tin over Nickel  
F = Gold flash over Nickel

- ④ Contact style :  
D = Downside contact
- ⑤ Color : 0 = Nature
- ⑥ Packing : R0 = Tape & Reel

- ⑦ Pitch : 05=0.5mm
- ⑧ NH = For Lead Free soldering process and Halogen-Free

**CF50 Series 0.50mm(.020")H=1.46 SMT ZIF One-Touch FFC/FPC Connectors**

CF

- ⊙ 1.46mm above the board
- ⊙ FFC/FPC zero insertion force and high retention force
- ⊙ Insulation: High temperature plastic UL 94V-0, Color Nature
- ⊙ Cover: High temperature plastic UL 94V-0, Color Black
- ⊙ Actuator designed easy for FFC/FPC installation and reliable operation
- ⊙ With metal fixed tabs to secure connector in place

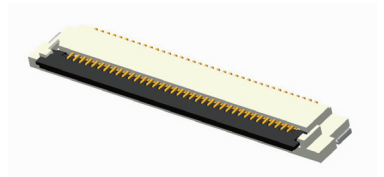

RoHS Compliant

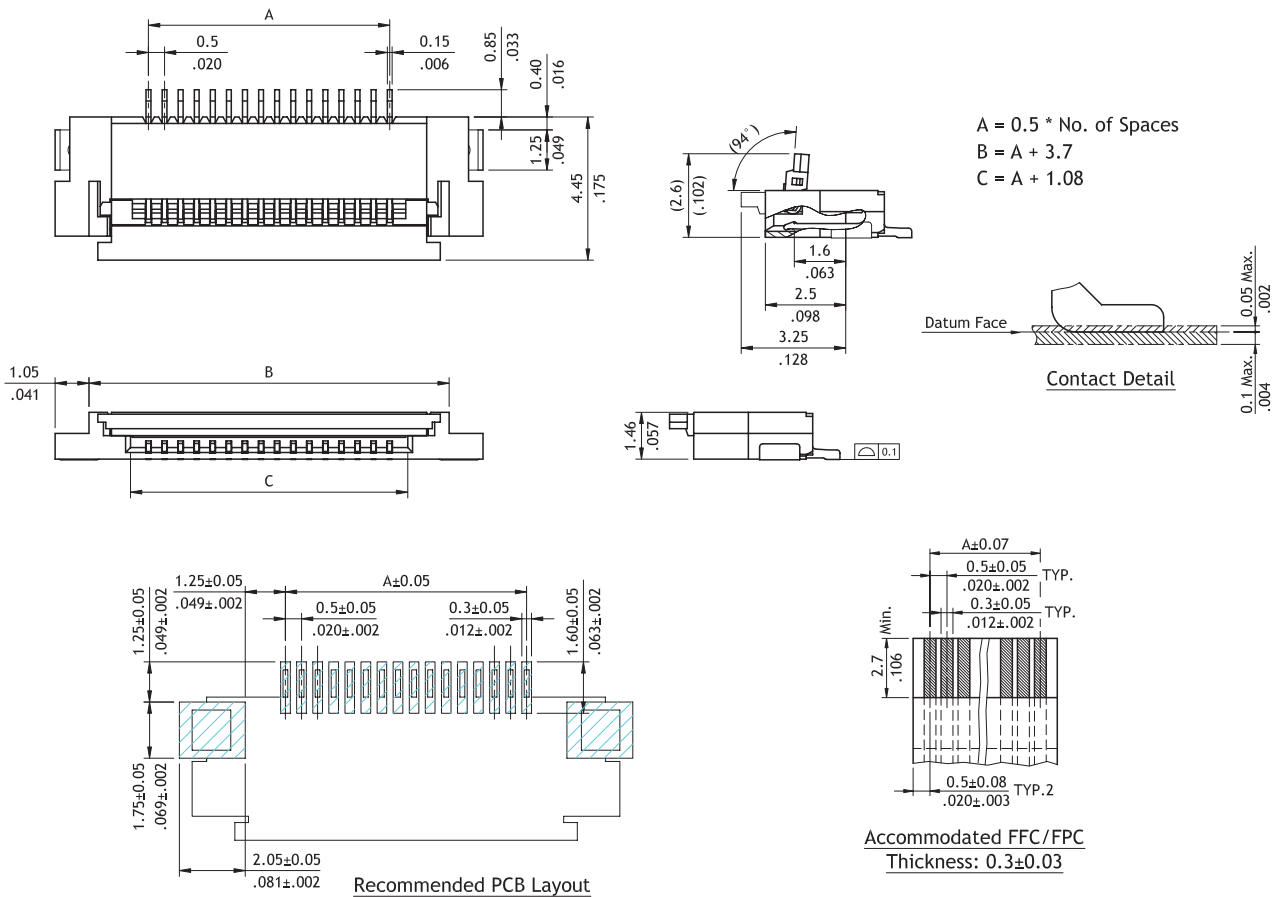

**Ordering Code**

① ② ③ ④ ⑤ ⑥ ⑦ ⑧  
**CF50 08 F D 0 RC - 05 - NH**

- ① Series No.
- ② No. of Circuits: 6, 8  
\*Circuits not found above please consult manufacturer\*
- ③ Plating Code:  
F = Gold flash over Nickel
- ④ Contact Style:  
D = Downside Contact
- ⑤ Color: 0 = Nature
- ⑥ Packing:  
RC = Tape & Reel
- ⑦ Pitch: 05 = 0.50 mm
- ⑧ NH = For Lead Free IR process and Halogen-Free

**CF50 Series 0.50mm(.020")H=1.46 SMT ZIF One-Touch FFC/FPC Connectors**

- ⊙ 1.46mm above the board
- ⊙ FFC/FPC zero insertion force and high retention force
- ⊙ Insulation: High temperature plastic UL 94V-0, Color Nature
- ⊙ Cover: High temperature plastic UL 94V-0, Color Black
- ⊙ Actuator designed easy for FFC/FPC installation and reliable operation
- ⊙ With metal fixed tabs to secure connector in place

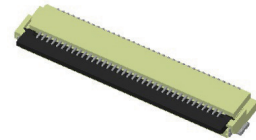

RoHS Compliant  

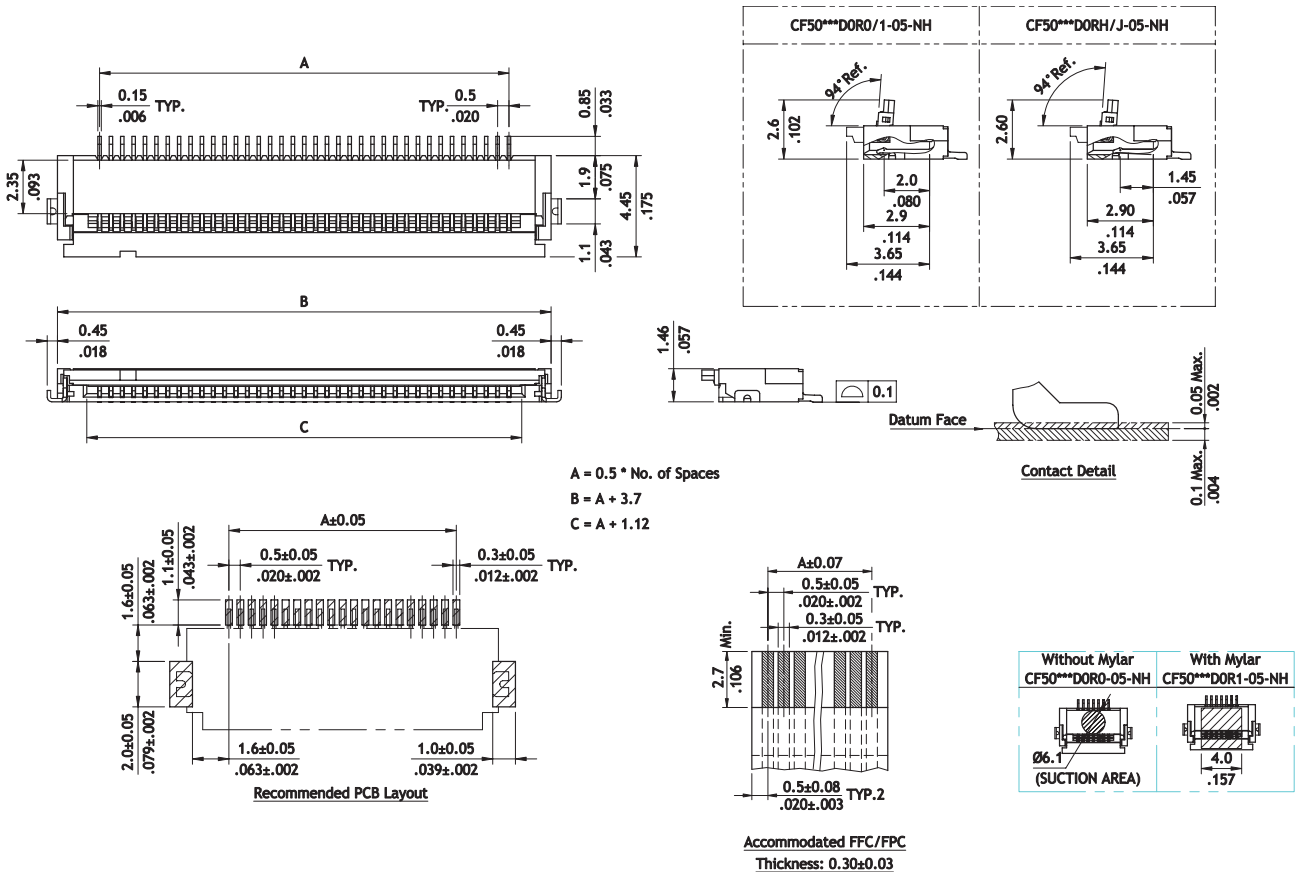

- ① Series No.
- ② No. of Circuits: 4 ~ 61
- ③ Plating Code:  
1 = Matte Tin over Nickel  
F = Gold flash over Nickel
- ④ Contact Style :  
D = Downside Contact

- ⑤ Color: 0 = Nature
- ⑥ Packing:  
R0 = Tape & Reel without Mylar  
R1 = Tape & Reel with Mylar  
RH = Tape & Reel without Mylar  
RJ = Tape & Reel with Mylar
- ⑦ Pitch: 05 = 0.50 mm
- ⑧ NH = For Lead Free IR process and Halogen-Free

**CF50 Series 0.50mm(.020")H=1.46 SMT ZIF One-Touch FFC/FPC Connectors**

CF

- ⊙ 1.46mm above the board
- ⊙ FFC/FPC zero insertion force and high retention force
- ⊙ Insulation: High temperature plastic UL 94V-0, Color Nature
- ⊙ Cover: High temperature plastic UL 94V-0, Color Black
- ⊙ Actuator designed easy for FFC/FPC installation and reliable operation
- ⊙ With metal fixed tabs to secure connector in place

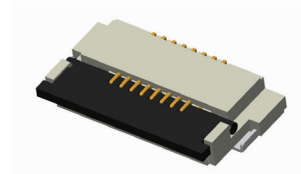

RoHS Compliant

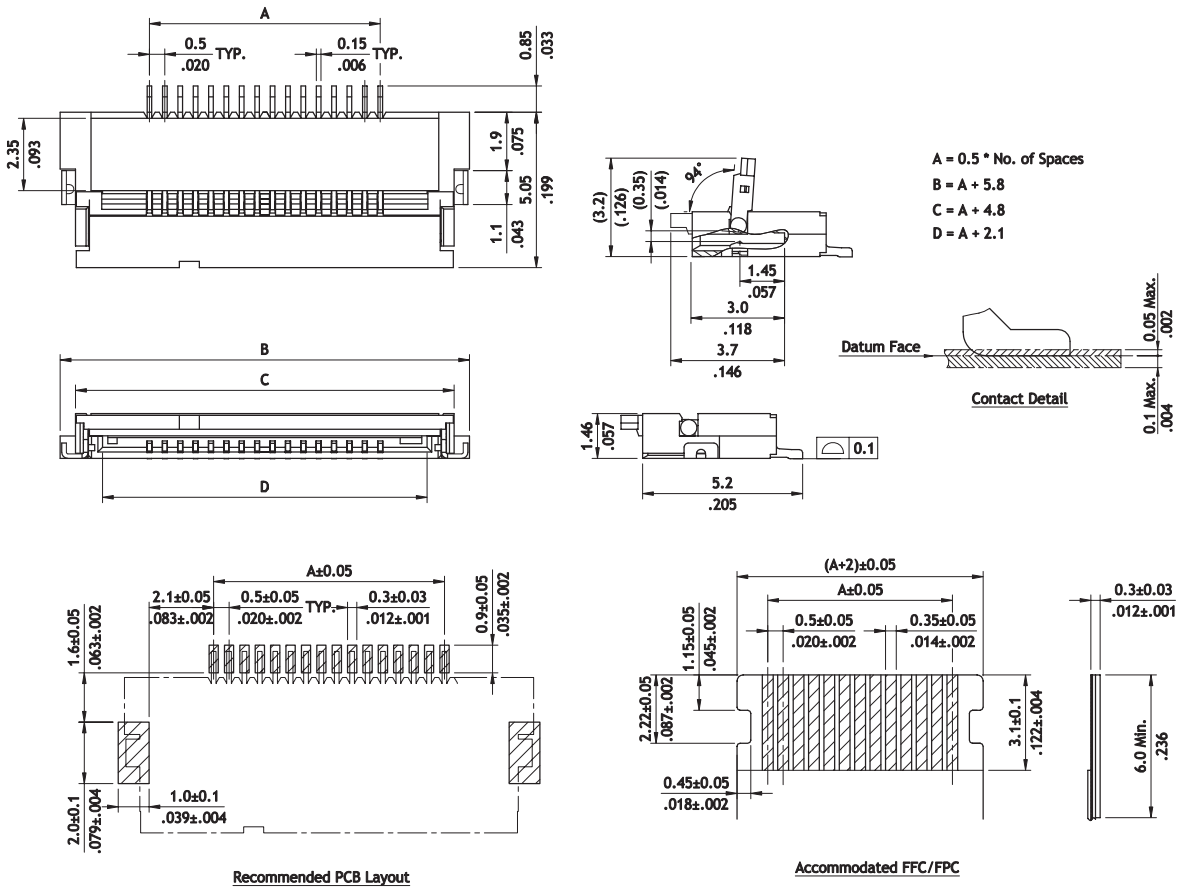

**Ordering Code**

① ② ③ ④ ⑤ ⑥ ⑦ ⑧  
**CF50 23 F D 0 RG - 05 - NH**

- ① Series No.
- ② No. of Circuits: 8, 23  
\*Circuits not found above please consult manufacturer\*
- ③ Plating Code:  
F = Gold flash over Nickel
- ④ Contact Style:  
D = Downside Contact
- ⑤ Color: 0 = Nature
- ⑥ Packing:  
RG = Tape & Reel
- ⑦ Pitch: 05 = 0.50 mm
- ⑧ NH = For Lead Free IR process and Halogen-Free

**CF50 Series 1.00mm(.039")H=1.46 SMT ZIF One-Touch FFC/FPC Connectors**

- ⊙ 1.46mm above the board
- ⊙ FFC/FPC zero insertion force and high retention force
- ⊙ Insulation: High temperature plastic UL 94V-0, Color Nature
- ⊙ Cover: High temperature plastic UL 94V-0, Color Black
- ⊙ Actuator designed easy for FFC/FPC installation and reliable operation
- ⊙ With metal fixed tabs to secure connector in place

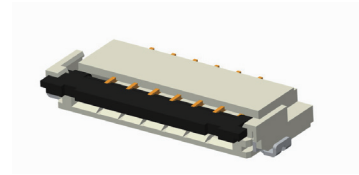

RoHS Compliant

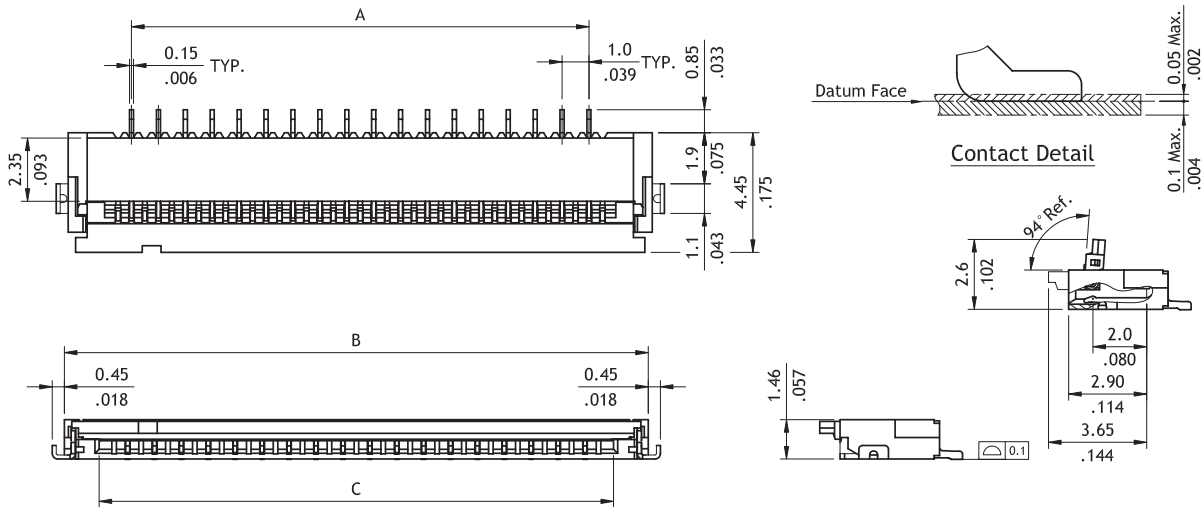

A = 1.0 \* No. of Spaces  
 B = A + 4.7  
 C = A + 2.12

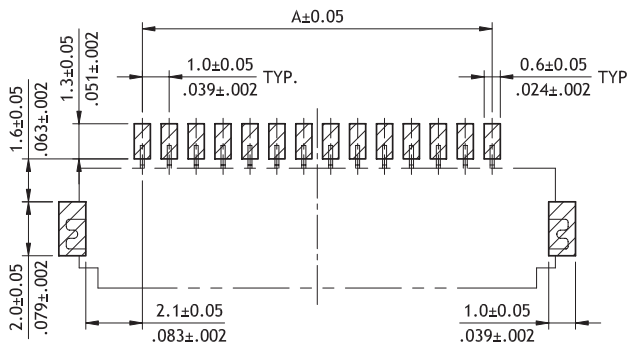

Recommended PCB Layout

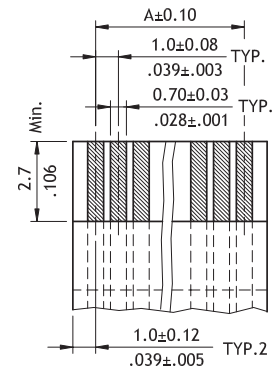

Accommodated FFC/FPC Thickness: 0.3±0.03

**Ordering Code**

① ② ③ ④ ⑤ ⑥ ⑦ ⑧  
**CF50 24 1 D 0 R0 - 10 - NH**

- ① Series No.
- ② No. of Circuits: 04 ~ 30  
(Available: 4,6,8,10,12,18,24,26,30)  
\*Circuits not found above please consult manufacturer\*

- ③ Plating Code:  
1 = Matte Tin over Nickel  
F = Gold flash over Nickel
- ④ Contact Style:  
D = Downside Contact
- ⑤ Color: 0 = Nature

- ⑥ Packing:  
R0 = Tape & Reel without Mylar  
R1 = Tape & Reel with Mylar
- ⑦ Pitch: 10 = 1.00 mm
- ⑧ NH = For Lead Free IR process and Halogen-Free

**CF50 Series 1.00mm(.039")H=1.46 SMT ZIF One-Touch FFC/FPC Connectors**

CF

- ⊙ 1.46mm above the board
- ⊙ FFC/FPC zero insertion force and high retention force
- ⊙ Insulation: High temperature plastic UL 94V-0, Color Nature
- ⊙ Cover: High temperature plastic UL 94V-0, Color Black
- ⊙ Actuator designed easy for FFC/FPC installation and reliable operation
- ⊙ With metal fixed tabs to secure connector in place

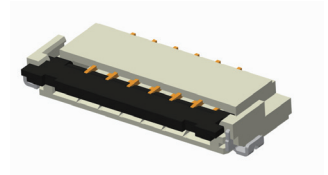

RoHS Compliant

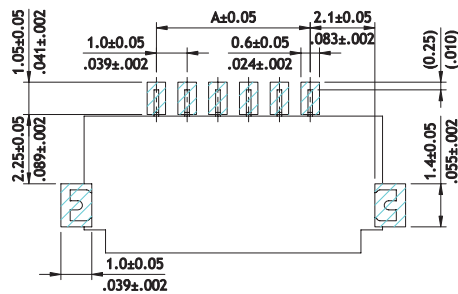
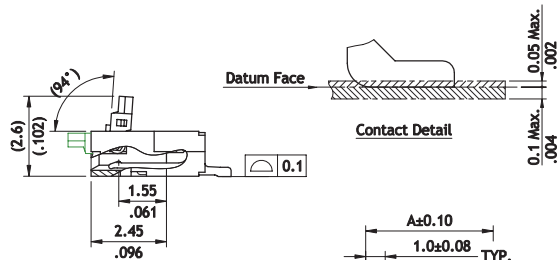
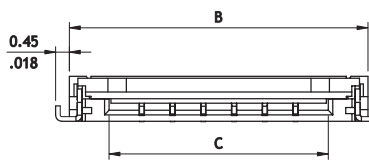
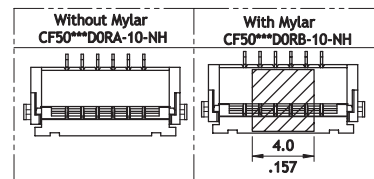
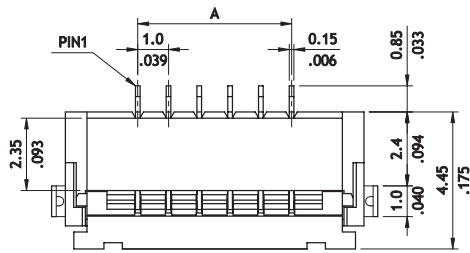

Recommended PCB Layout

A = 1.0 \* No. of Spaces  
 B = A + 4.7  
 C = A + 2.12

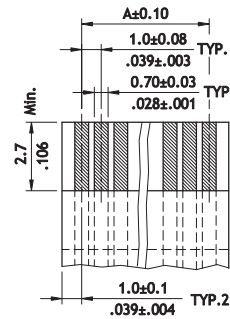

Accommodated FFC/FPC  
 Thickness: 0.3±0.03

**Ordering Code**

① ② ③ ④ ⑤ ⑥ ⑦ ⑧  
**CF50 08 1 D 0 RA - 10 - NH**

- ① Series No.
- ② No. of Circuits: 4, 6, 8, 10  
 \*Circuits not found above please consult manufacturer\*

- ③ Plating Code:  
 1 = Matte Tin over Nickel  
 F = Gold flash over Nickel
- ④ Contact Style:  
 D = Downside Contact
- ⑤ Color: 0 = Nature

- ⑥ Packing:  
 RA = Tape & Reel without Mylar  
 RB = Tape & Reel with Mylar
- ⑦ Pitch: 10 = 1.00 mm
- ⑧ NH = For Lead Free IR process and Halogen-Free

**CF50 Series 1.00mm(.039")H=1.46 SMT ZIF One-Touch FFC/FPC Connectors**

- ⊙ 1.46mm above the board
- ⊙ FFC/FPC zero insertion force and high retention force
- ⊙ Insulation: High temperature plastic UL 94V-0, Color Nature
- ⊙ Cover: High temperature plastic UL 94V-0, Color Black
- ⊙ Actuator designed easy for FFC/FPC installation and reliable operation
- ⊙ With metal fixed tabs to secure connector in place

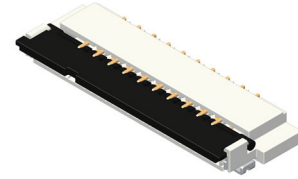

RoHS Compliant  

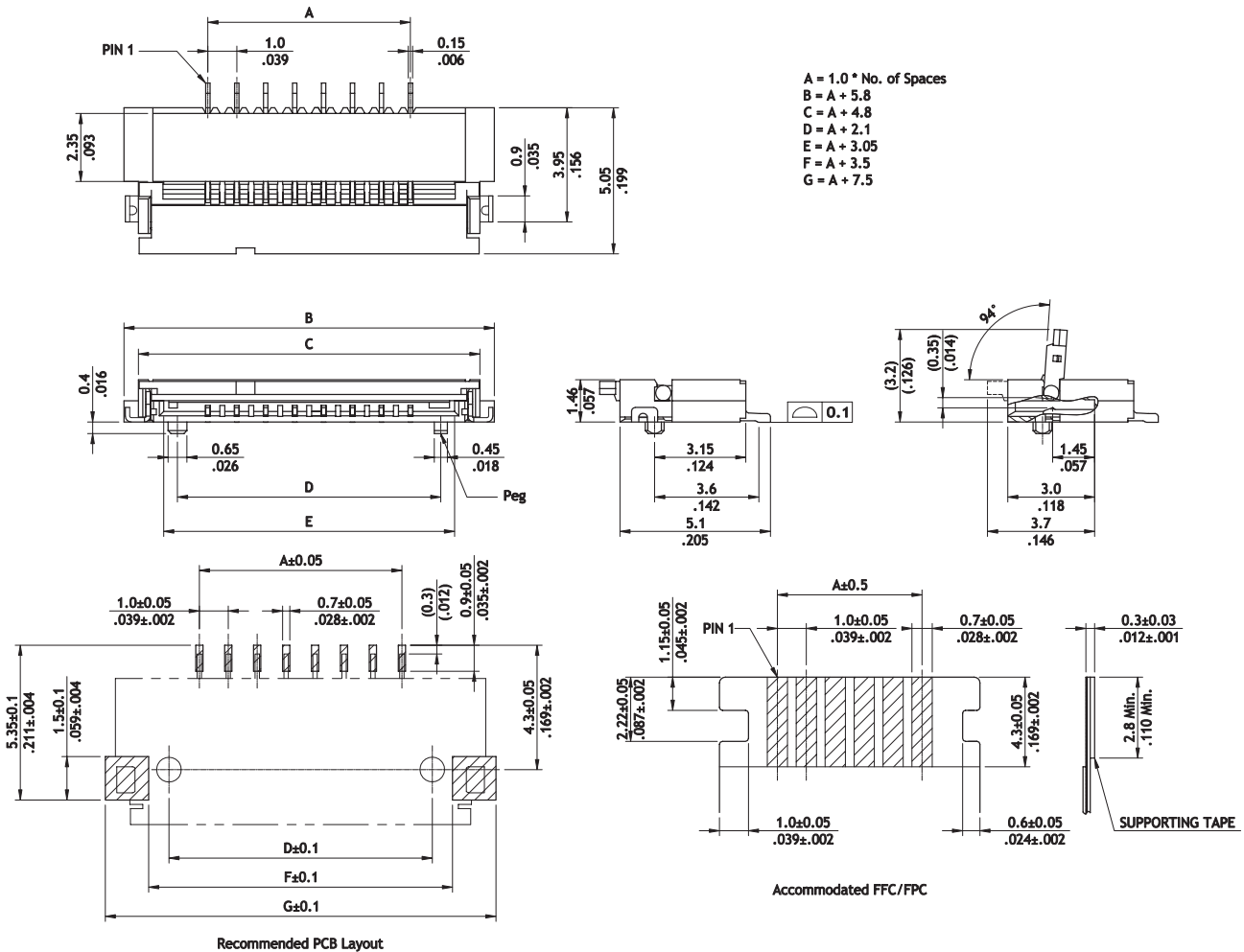

**Ordering Code**

① ② ③ ④ ⑤ ⑥ ⑦ ⑧  
**CF50 12 1 D 0 RE - 10 - NH**

① Series No.

② No. of Circuits: 4,12

\*Circuits not found above please consult manufacturer\*

③ Plating Code:

1 = Matte Tin over Nickel

F = Gold flash over Nickel

④ Contact Style:

D = Downside Contact

⑤ Color: 0 = Nature

⑥ Packing:

RE = Tape & Reel with Pegs

RD = Tape & Reel without Pegs

⑦ Pitch: 10 = 1.00 mm

⑧ NH = For Lead Free IR process and Halogen-Free

**CF50 Series 0.50/1.00mm (.020"/.039")H=1.5 SMT ZIF One-Touch FFC/FPC Connectors**

CF

- ⊙ 1.50mm above the board
- ⊙ FFC/FPC zero insertion force and high retention force
- ⊙ Insulation: High temperature plastic UL 94V-0, Color Nature
- ⊙ Cover: High temperature plastic UL 94V-0, Color Black
- ⊙ Actuator designed easy for FFC/FPC installation and reliable operation
- ⊙ With metal fixed tabs to secure connector in place

RoHS Compliant

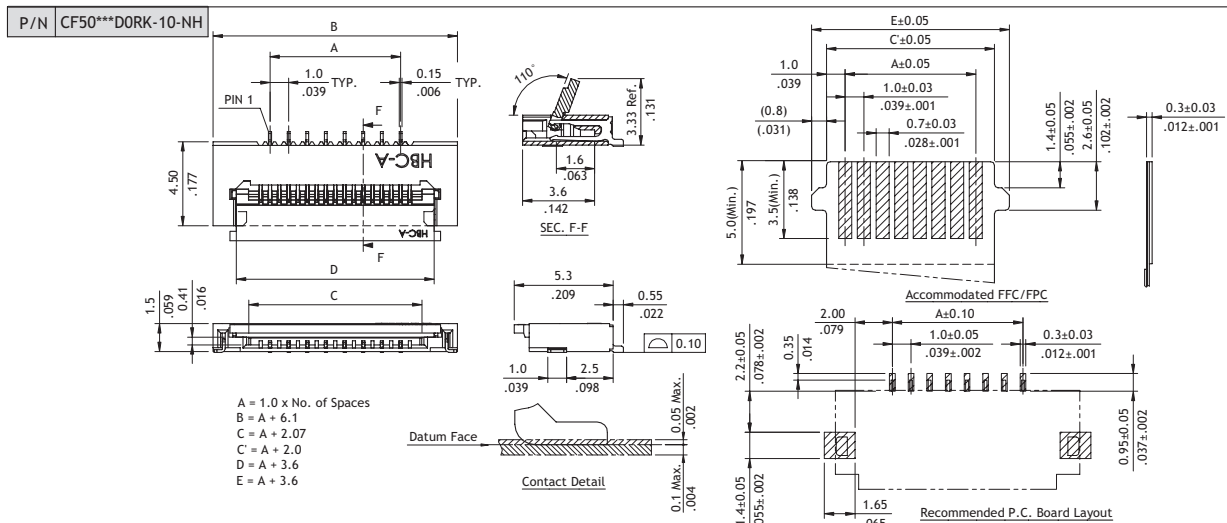
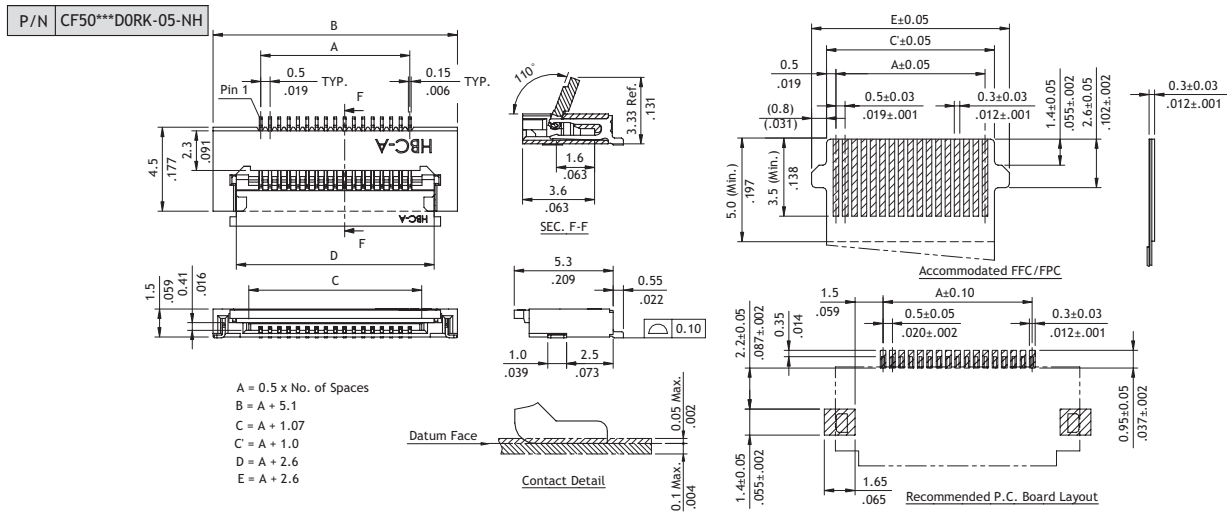
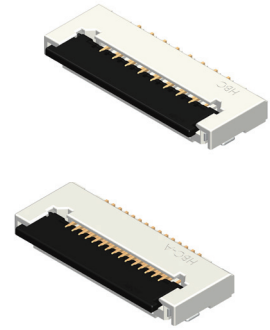

**Ordering Code**

①
②
③
④
⑤
⑥
⑦
⑧  
CF50
10
1
D
0
RK
-10-
NH

- ① Series No.
- ② No. of Circuits:  
0.5 pitch: 12, 20, 22, 26  
1.0 pitch: 10

- ③ Plating Code:  
1 = Matte Tin over Nickel  
F = Gold flash over Nickel
- ④ Contact Style:  
D = Downside Contact
- ⑤ Color: 0 = Nature

- ⑥ Packing: RK = Tape & Reel without Mylar
- ⑦ Pitch: 10 = 1.00 mm  
05 = 0.50 mm
- ⑧ NH = For Lead Free IR process and Halogen-Free

**CF61 Series 0.50mm(.020")H=1.75 SMT ZIF One-Touch FFC/FPC Connectors**

- ⊙ 1.75mm above the board
- ⊙ FFC/FPC zero insertion force and high retention force
- ⊙ Insulation: High temperature plastic UL 94V-0, Color Nature
- ⊙ Cover: High temperature plastic UL 94V-0, Color Black
- ⊙ Actuator designed easy for FFC/FPC installation and reliable operation
- ⊙ With metal fixed tabs to secure connector in place

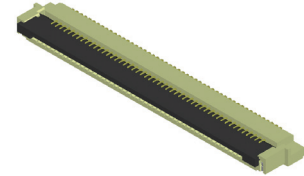

RoHS Compliant  

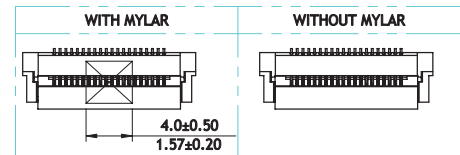
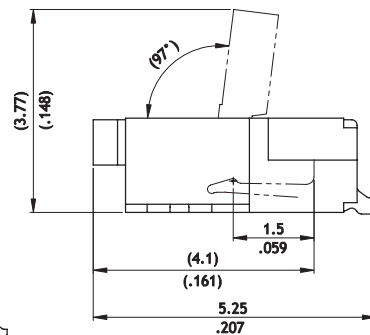
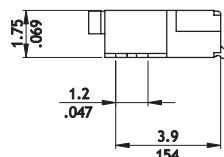
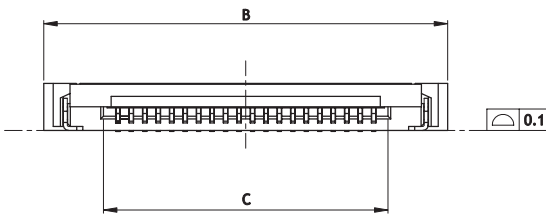
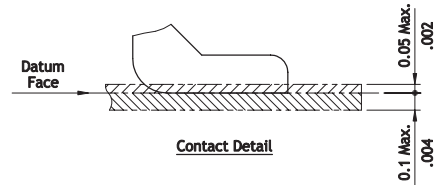
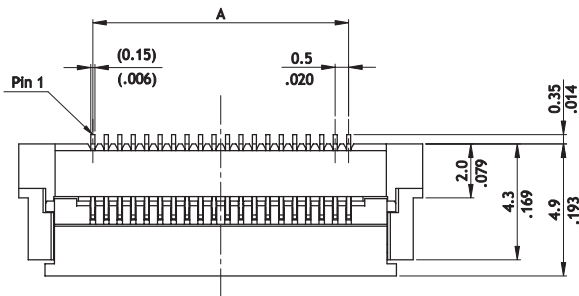

- A = 0.5 \* No. of Spaces
- B = A + 5.5
- C = A + 1.07
- D = A + 1.0
- E = A + 2.6

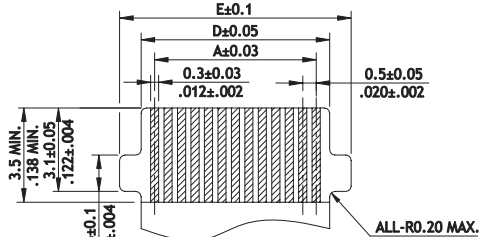
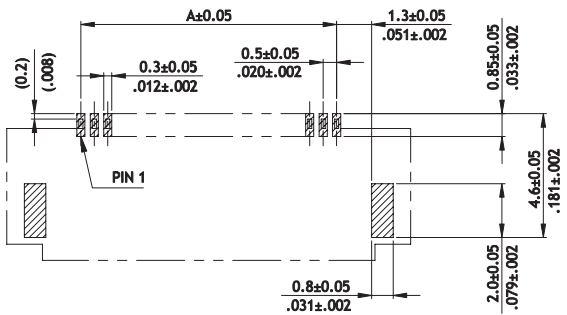

(THICKNESS: 0.3±0.03)  
APPLICABLE FFC/FPC DIM. (REF)

**Ordering Code**

① ② ③ ④ ⑤ ⑥ ⑦ ⑧ ⑨  
**CF61 40 1 D 0 R 0 - 05 - NH**

- ① Series No.
- ② No. of Circuits: 04 ~ 60  
(Available : 4~10 , 12, 14, 16, 17, 20,26, 30, 40, 44, 50, 60)  
\*Circuits not found above please consult manufacturer\*

- ③ Plating Code:  
1 = Matte Tin over Nickel  
2 = Gold flash over Nickel
- ④ Contact Style:  
D = Downside Contact
- ⑤ Color: 0 = Nature
- ⑥ Packing: R = Tape & Reel  
T = Tube

- ⑦ Other Options:  
0 = Without Mylar  
M = With Mylar
- ⑧ Pitch: 05 = 0.50 mm
- ⑨ NH = For Lead Free IR process and Halogen-Free

**CF31 Series 0.50mm(.020")H=1.95 SMT ZIF One-Touch FFC/FPC Connectors**

CF

- ⊙ 1.95mm above the board
- ⊙ FFC/FPC zero insertion force and high retention force
- ⊙ Insulation: High temperature plastic UL 94V-0, Color Nature
- ⊙ Cover: High temperature plastic UL 94V-0, Color Black
- ⊙ Actuator designed easy for FFC/FPC installation and reliable operation
- ⊙ With metal fixed tabs to secure connector in place

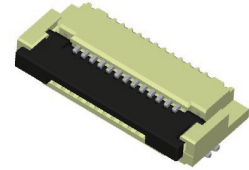

RoHS Compliant

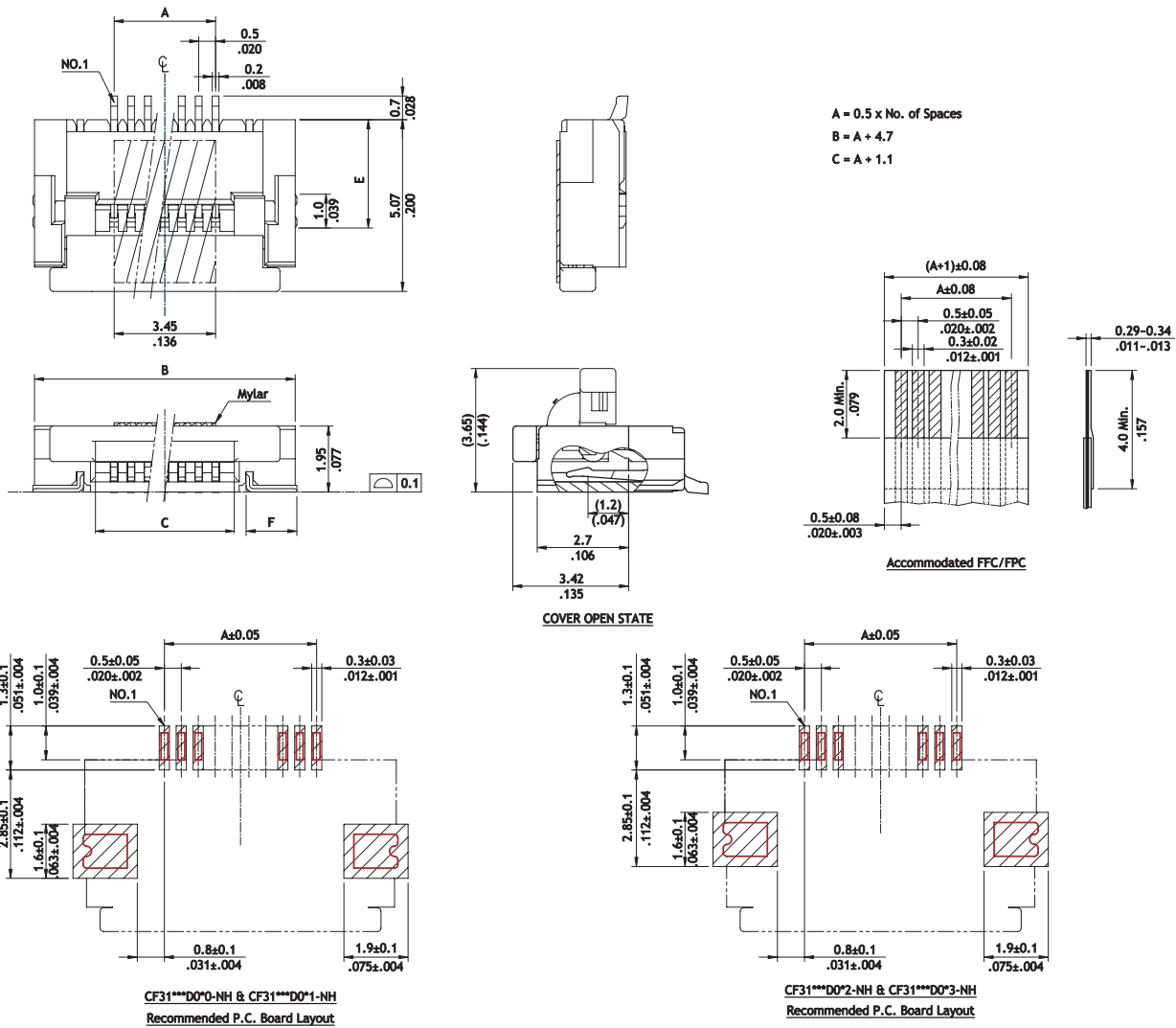

**Ordering Code**

① ② ③ ④ ⑤ ⑥ ⑦ ⑧ ⑨  
**CF31 61 1 D 0 R 0 - 05 - NH**

- ① Series No.
- ② No. of Circuits: 04 ~ 61  
\*Circuits not found above please consult manufacturer\*
- ③ Plating Code:  
1 = Matte Tin over Nickel  
2 = Selective Gold flash over Nickel
- ④ Contact Style:  
D = Downside Contact
- ⑤ Color: 0 = Nature
- ⑥ Packing: R = Tape & Reel
- ⑦ Other Options:  
0 = Without Mylar, E=3.20mm ,F=1.40  
1=With Mylar, E=3.20mm ,F=1.40  
2 =Without Mylar, E=2.85mm,F=1.50  
3=With Mylar, E=2.85mm,F=1.50
- ⑧ Pitch: 05 = 0.50 mm
- ⑨ NH = For Lead Free IR process and Halogen-Free

**CF31 Series 1.00mm(.039")H=1.95 SMT ZIF One-Touch FFC/FPC Connectors**

- ⊙ 1.95mm above the board
- ⊙ FFC/FPC zero insertion force and high retention force
- ⊙ Insulator: High temperature plastic UL 94V-0, Color Nature
- ⊙ Cover: High temperature plastic UL 94V-0, Color Black
- ⊙ Designed easy for FFC/FPC installation and reliable operation
- ⊙ With metal fixed tabs to secure connector in place

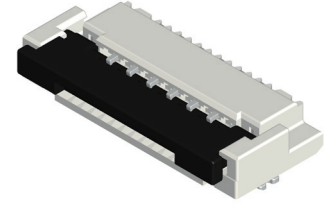

RoHS Compliant  

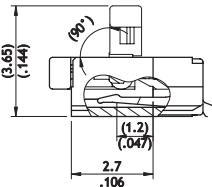
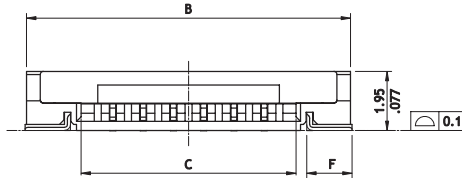
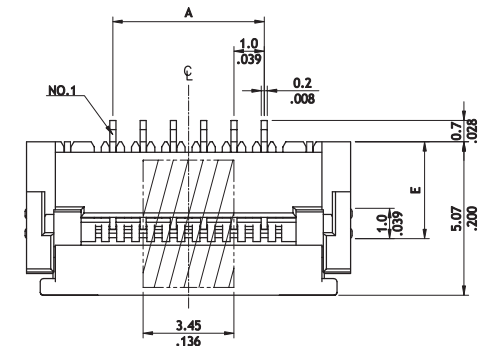

COVER OPEN STATE

- A = 1.0 x No. of Spaces
- B = A + 5.7
- C = A + 2.1
- D = A + 2.1

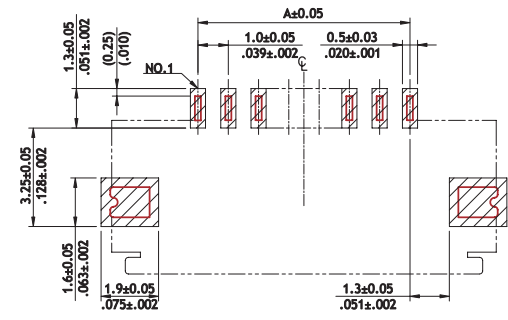

CF31\*\*\*D0\*0-10-NH & CF31\*\*\*D0\*1-10-NH  
Recommended P.C. Board Layout

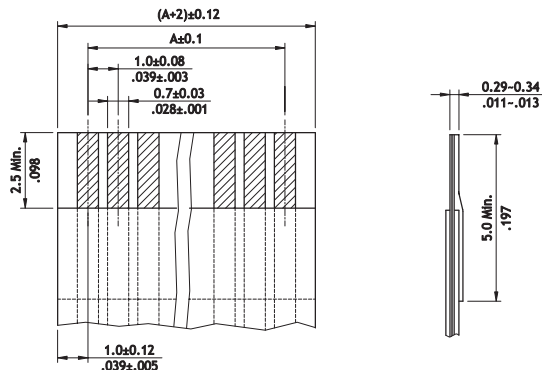

Accommodated FFC/FPC

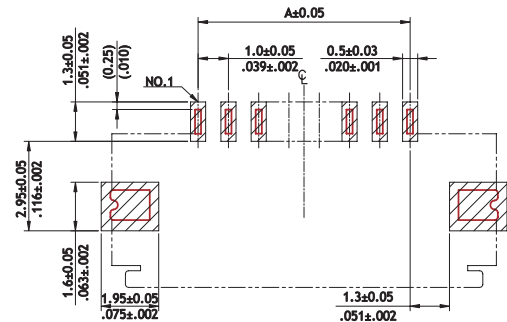

CF31\*\*\*D0\*2-10-NH & CF31\*\*\*D0\*3-10-NH  
Recommended P.C. Board Layout

**Ordering Code**

① ② ③ ④ ⑤ ⑥ ⑦ ⑧ ⑨  
**CF31 30 1 D 0 R 0 - 10 - NH**

- ① Series No.
- ② No. of Circuits: 04 ~ 30  
\*Circuits not found above please consult manufacturer\*
- ③ Plating Code:  
1 = Matte Tin over Nickel  
2 = Gold flash over Nickel
- ⑤ Color: 0 = Nature
- ⑥ Packing: R = Tape & Reel

- ⑦ Other Options:  
0= Without Mylar  
E=3.20mm,F=1.40  
1=With Mylar,  
E=3.20mm,F=1.40  
2=Without Mylar,  
E=2.85mm,F=1.50  
3=With Mylar,  
E=2.85mm,F=1.50

- ⑧ Pitch: 10 = 1.00 mm
- ⑨ NH = For Lead Free IR process and Halogen-Free

**CF31 Series 1.00mm(.039")H=2.00 SMT ZIF One-Touch FFC/FPC Connectors**

CF

- ⊙ 2.00 mm above the board
- ⊙ FFC/FPC zero insertion force and high retention force
- ⊙ Insulator: High temperature plastic UL 94V-0, Color Nature
- ⊙ Cover: High temperature plastic UL 94V-0, Color Black
- ⊙ Designed easy for FFC/FPC installation and reliable operation
- ⊙ With metal fixed tabs to secure connector in place

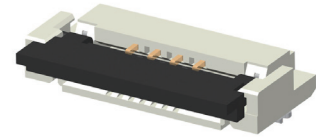

**RoHS** Compliant

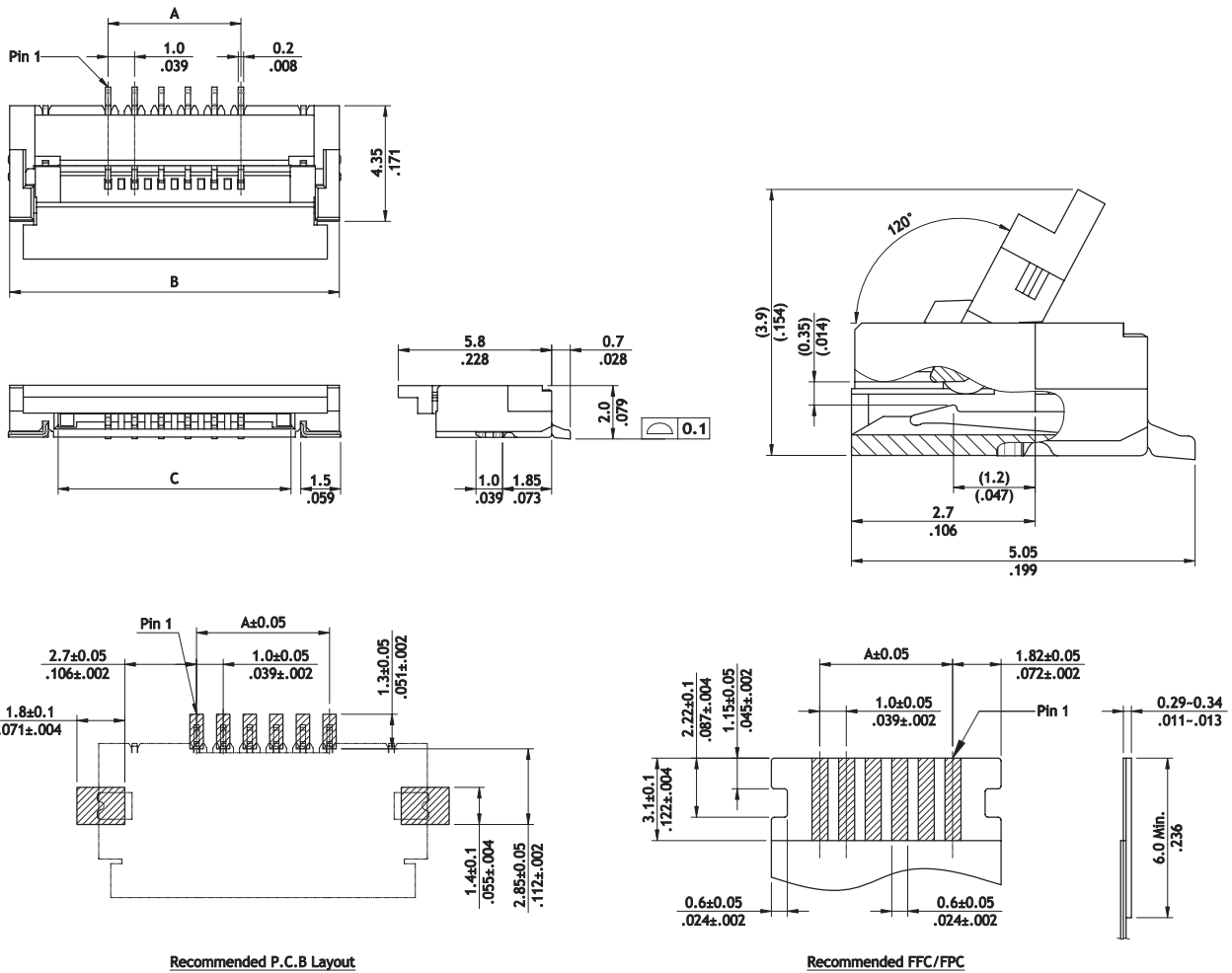

**Ordering Code**

① ② ③ ④ ⑤ ⑥ ⑦ ⑧ ⑨  
**CF31 04 1 D 0 R J - 10 - NH**

- ① Series No.
- ② No. of Circuits: 04 ~ 31  
(Available: 4, 6, 12)  
\*Circuits not found above please consult manufacturer\*
- ③ Plating Code:  
2 = Gold flash over Nickel
- ④ Contact Style:  
D = Downside Contact
- ⑤ Color: 0 = Nature
- ⑥ Packing: R = Tape & Reel
- ⑦ Other Options:  
J = With Inner Lock
- ⑧ Pitch: 10 = 1.00 mm
- ⑨ NH = For Lead Free IR process and Halogen-Free

**CF34 Series 0.50mm(.020")H=1.95 SMT ZIF One-Touch FFC/FPC Connectors**

- ⊙ 1.95mm above the board
- ⊙ FFC/FPC zero insertion force and high holding force
- ⊙ Insulation: High temperature plastic UL 94V-0, Color Nature
- ⊙ Cover: High temperature plastic UL 94V-0, Color Black
- ⊙ Actuator designed easy for FFC/FPC installation and reliable operation
- ⊙ With metal fixed tabs to secure connector in place

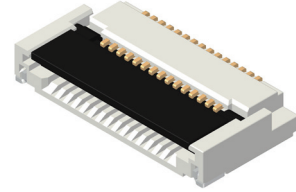

**RoHS** Compliant  

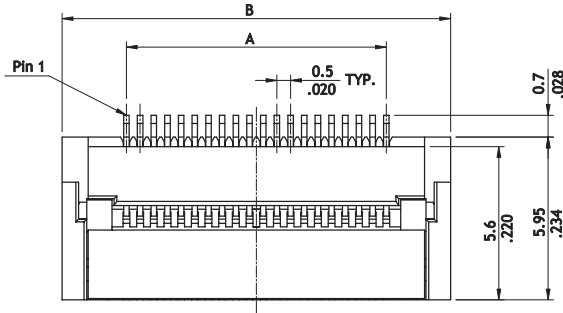

A = 0.5 x No. of Spaces  
 B = A + 4.7  
 C = A + 1.06

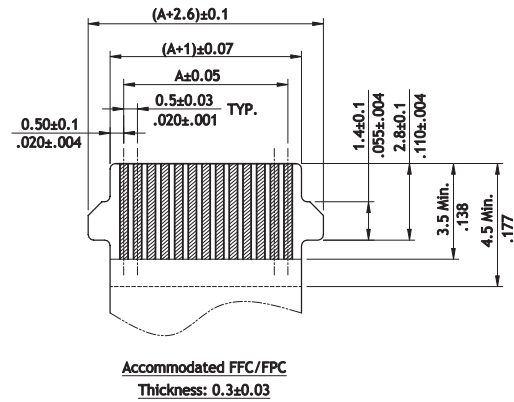
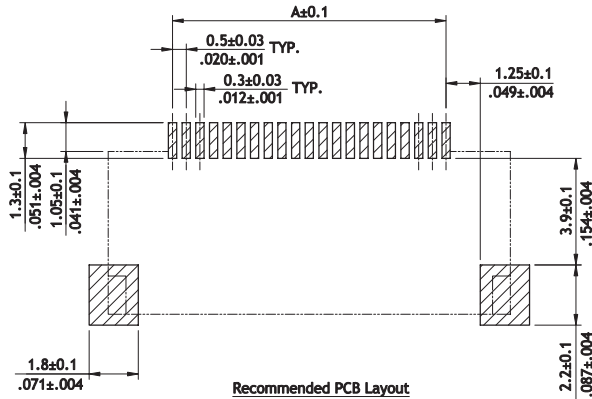
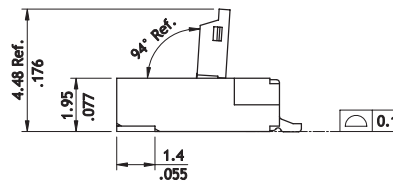
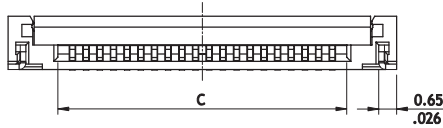
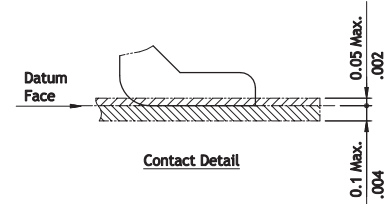

**Ordering Code**

① ② ③ ④ ⑤ ⑥ ⑦ ⑧ ⑨  
**CF34 06 1 D 0 R 0 - 05 - NH**

- ① Series No.
- ② No. of Circuits: 04 ~ 60  
(Available: 6, 18, 54)  
\*Circuits not found above please consult manufacturer\*
- ③ Plating Code:  
1 = Matte Tin over Nickel  
2 = Gold flash over Nickel
- ④ Contact Style:  
D = Downside Contact
- ⑤ Color: 0 = Nature
- ⑥ Packing: R = Tape & Reel
- ⑦ Other Options:  
0 = Without Mylar (Standard)  
\*Special options consult manufacturer
- ⑧ Pitch: 05 = 0.50 mm
- ⑨ NH = For Lead Free IR process and Halogen-Free

**CF34 Series 1.00mm(.039")H=1.95 SMT ZIF One-Touch FFC/FPC Connectors**

CF

- ⊙ 1.95mm above the board
- ⊙ FFC/FPC zero insertion force and high holding force
- ⊙ Insulation: High temperature plastic UL 94V-0, Color Nature
- ⊙ Cover: High temperature plastic UL 94V-0, Color Black
- ⊙ Actuator designed easy for FFC/FPC installation and reliable operation
- ⊙ With metal fixed tabs to secure connector in place

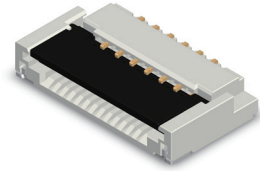

RoHS Compliant

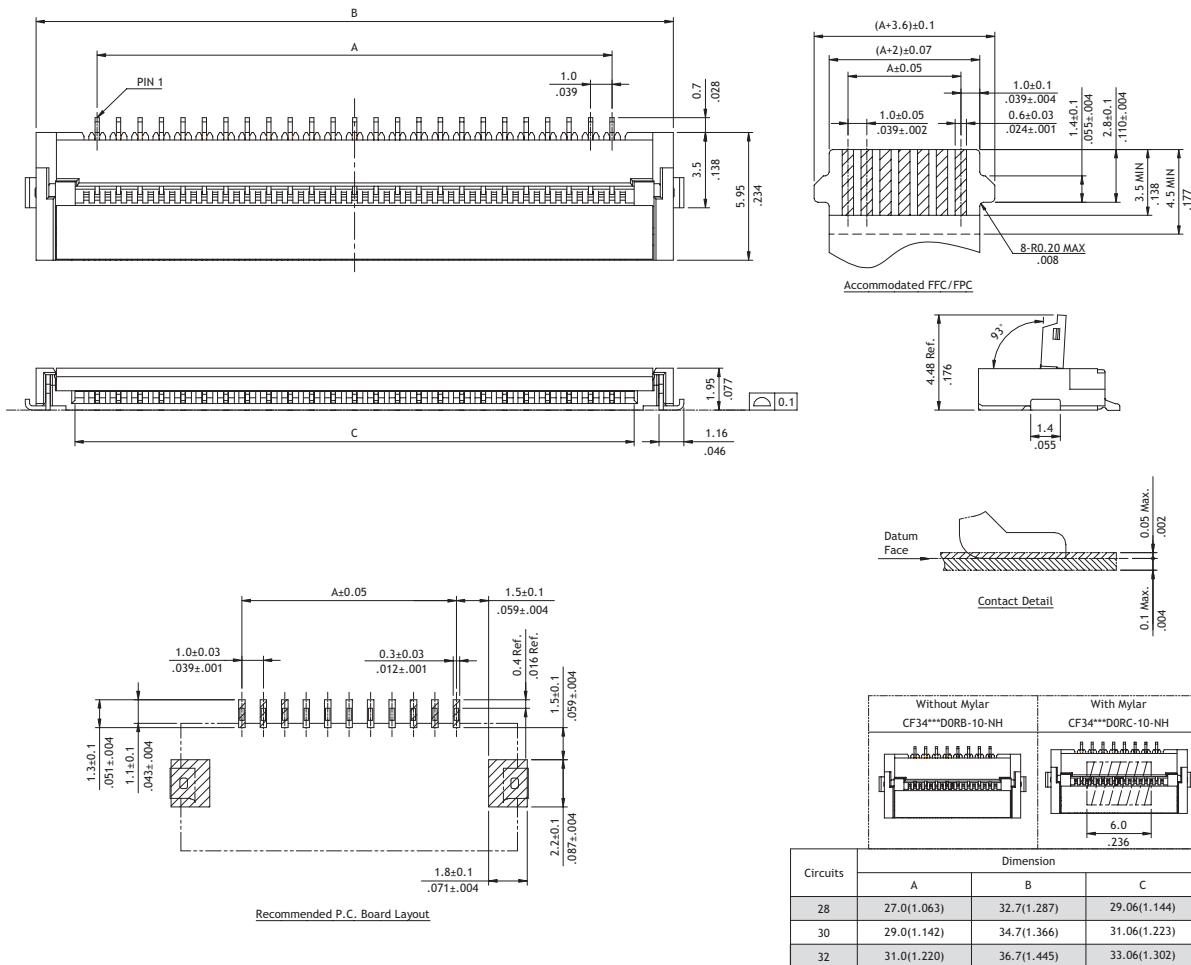

**Ordering Code**

① ② ③ ④ ⑤ ⑥ ⑦ ⑧ ⑨  
**CF34 30 1 D 0 R B - 10 - NH**

- ① Series No.
- ② No. of Circuits: 04 ~ 60  
(Available: 28,30,32)  
\*Circuits not found above please consult manufacturer\*
- ③ Plating Code:  
1 = Matte Tin over Nickel  
F = 0.8μ"Gold flash over Nickel

- ④ Contact Style:  
D = Downside Contact
- ⑤ Color: 0 = Nature
- ⑥ Packing: R = Tape & Reel

- ⑦ Other Options:  
B = Without Mylar (Standard)  
\*Special options consult manufacturer
- ⑧ Pitch: 10 = 1.00 mm
- ⑨ NH = For Lead Free IR process and Halogen-Free

**CF25 Series 0.50mm(.020")H=2.20 SMT ZIF One-Touch FFC/FPC Connectors**

- ⊙ 2.2mm above the board
- ⊙ FFC/FPC zero insertion force and high retention force
- ⊙ Insulator: High temperature plastic UL 94V-0, Color Nature
- ⊙ Cover: High temperature plastic UL 94V-0, Color Black
- ⊙ Designed easy for FFC/FPC installation and reliable operation
- ⊙ With metal fixed tabs to secure connector in place

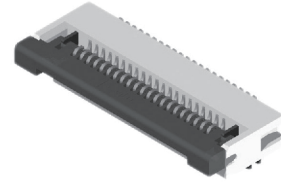

RoHS Compliant

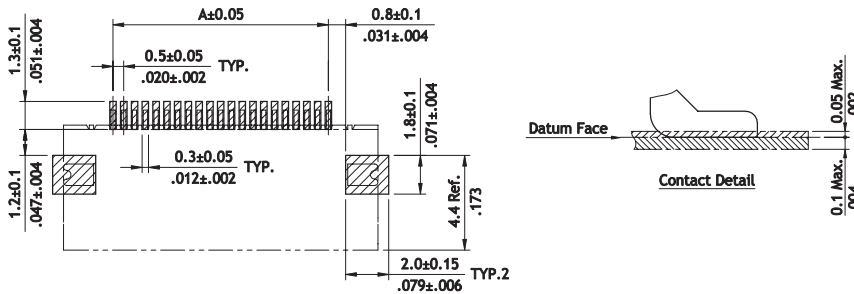
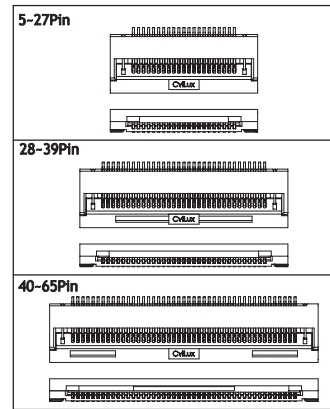
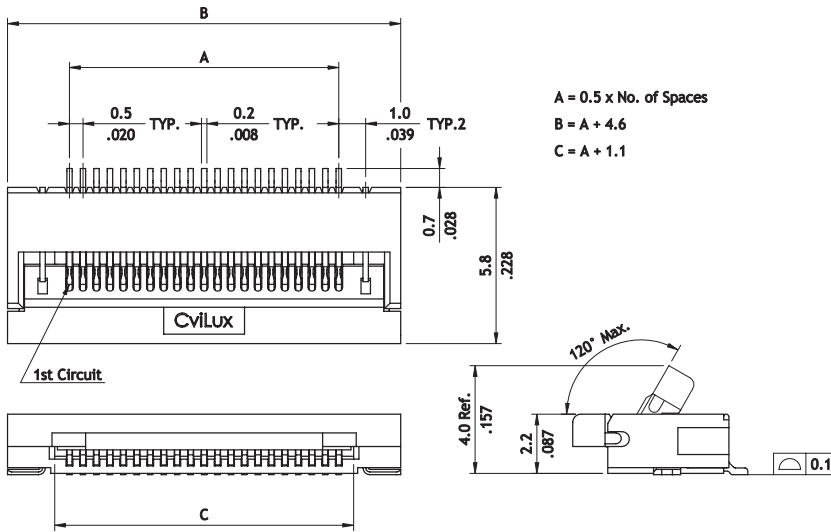

Recommended PCB Layout

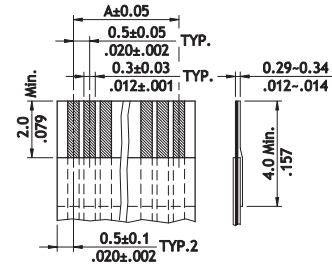
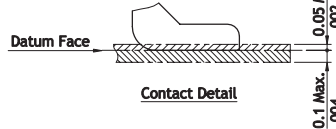

Accommodated FFC/FPC

**Ordering Code**

① ② ③ ④ ⑤ ⑥ ⑦ ⑧ ⑨  
**CF25 65 1 D 0 R 0 - 05 - NH**

- ① Series No.
- ② No. of Circuits: 05 ~ 65  
\*Circuits not found above please consult manufacturer\*
- ③ Plating Code:  
1 = Matte Tin over Nickel  
F = Selective Gold flash over Nickel

- ④ Contact Style:  
D = Downside Contact
- ⑤ Color: 0 = Nature
- ⑥ Packing : R = Tape & Reel  
T = Tube

- ⑦ Other Options: 0 = Standard  
\*Special option consult manufacturer
- ⑧ Pitch: 05 = 0.50 mm
- ⑨ NH = For Lead Free IR process and Halogen-Free

**CF25 Series 0.50mm(.020")H=2.20 SMT ZIF One-Touch FFC/FPC Connectors**

CF

- ⊙ 2.2mm above the board
- ⊙ FFC/FPC zero insertion force and high retention force
- ⊙ Insulator: High temperature plastic UL 94V-0, Color Nature
- ⊙ Cover: High temperature plastic UL 94V-0, Color Black
- ⊙ Designed easy for FFC/FPC installation and reliable operation
- ⊙ With metal fixed tabs to secure connector in place

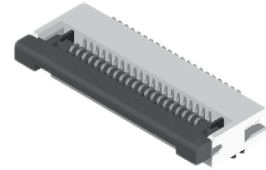

RoHS Compliant

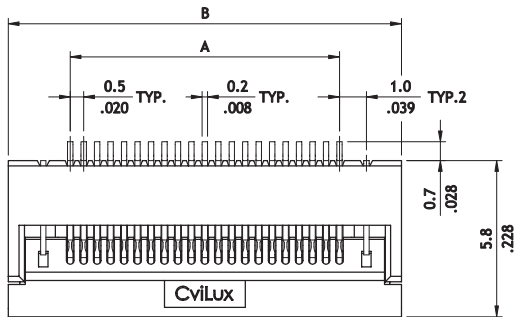

- A = 0.5 x No. of Spaces
- B = A + 4.6
- C = A + 1.1
- D = A + 1.0
- E = A + 2.6
- F = A + 2.1

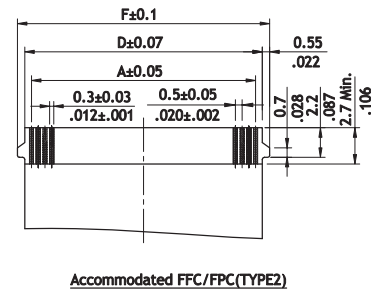
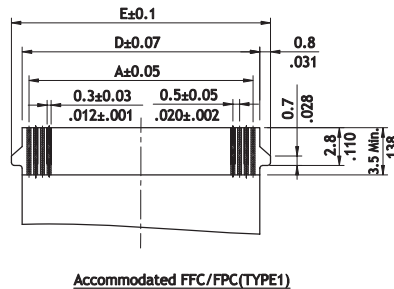
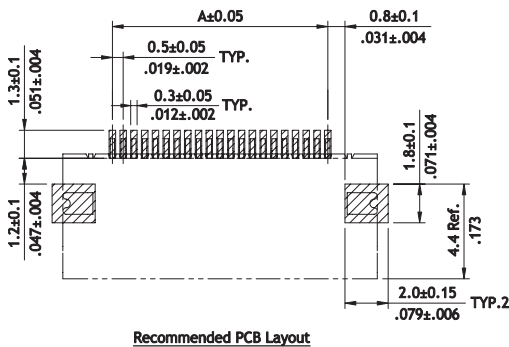
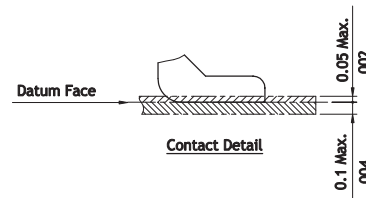
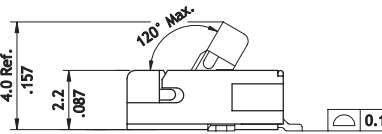
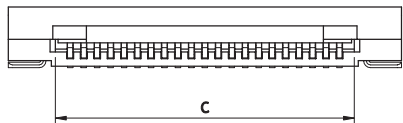

**Ordering Code**

① ② ③ ④ ⑤ ⑥ ⑦ ⑧ ⑨  
**CF25 65 1 D 0 R E - 05 - NH**

- ① Series No.
- ② No. of Circuits: 05 ~ 65  
\*Circuits not found above please consult manufacturer\*
- ③ Plating Code:  
1 = Matte Tin over Nickel  
F = Selective Gold flash over Nickel
- ④ Contact Style:  
D = Downside Contact
- ⑤ Color: 0 = Nature
- ⑥ Packing :  
R = Tape & Reel  
T = Tube
- ⑦ Other Options:  
D : Accommodated FFC/FPC (Type 1)  
E : Accommodated FFC/FPC (Type 2)
- ⑧ Pitch: 05 = 0.50 mm
- ⑨ NH = For Lead Free IR process and Halogen-Free

**CF25 Series 1.00mm(.039")H=2.20 SMT ZIF One-Touch FFC/FPC Connectors**

- ⊙ 2.2mm above the board
- ⊙ FFC/FPC zero insertion force and high retention force
- ⊙ Insulator: High temperature plastic UL 94V-0, Color Nature
- ⊙ Cover: High temperature plastic UL 94V-0, Color Black
- ⊙ Actuator designed easy for FFC/FPC installation and reliable operation
- ⊙ With metal fixed tabs to secure connector in place

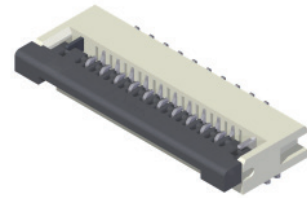

RoHS Compliant  

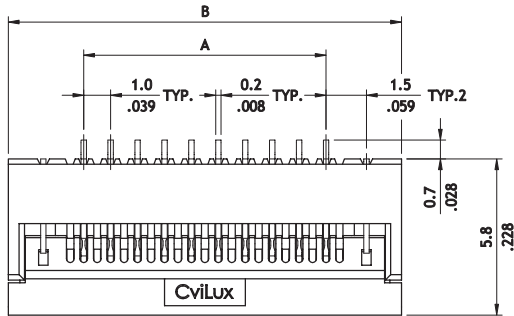

- A = 1.0 x No. of Spaces
- B = A + 5.6
- C = A + 2.1
- D = A + 2.0
- E = A + 3.6
- F = A + 3.1

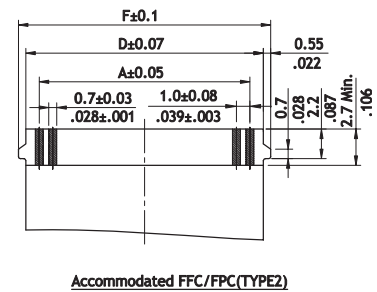
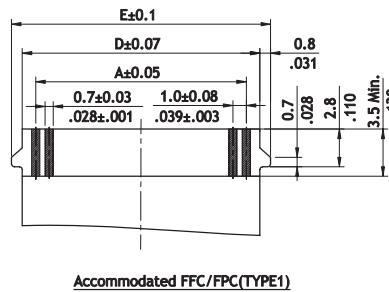
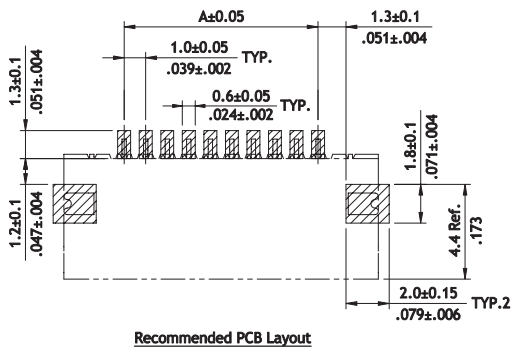
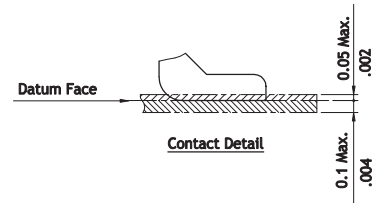
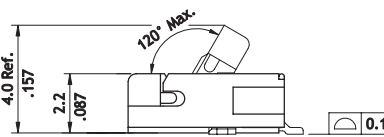
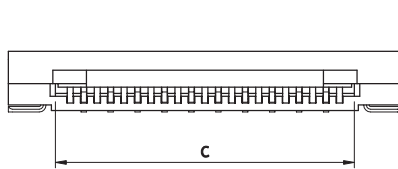

**Ordering Code**

① ② ③ ④ ⑤ ⑥ ⑦ ⑧ ⑨  
**CF25 32 1 D 0 R D - 10 - NH**

- ① Series No.
- ② No. of Circuits: 04 ~32  
\*Circuits not found above please consult manufacturer\*
- ③ Plating Code:  
1 = Matte Tin over Nickel  
F = Selective Gold flash over Nickel
- ④ Contact Style:  
D = Downside Contact
- ⑤ Color: 0 = Nature
- ⑥ Packing:  
R = Tape & Reel  
T = Tube
- ⑦ Other Options:  
D = Accommodated FFC/FPC (Type 1)  
E = Accommodated FFC/FPC (Type 2)
- ⑧ Pitch: 10 = 1.00 mm
- ⑨ NH = For Lead Free IR process and Halogen-Free

**CF25 Series 1.00mm(.039")H=2.40 DIP ZIF One-Touch FFC/FPC Connectors**

CF

- ⊙ 2.4mm above the board
- ⊙ FFC/FPC zero insertion force and high retention force
- ⊙ Insulator: High temperature plastic UL 94V-0, Color Nature
- ⊙ Cover: High temperature plastic UL 94V-0, Color Black
- ⊙ With metal Pegs

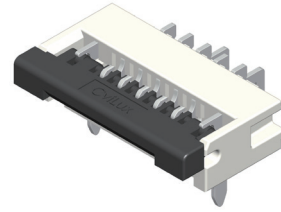

**RoHS** Compliant

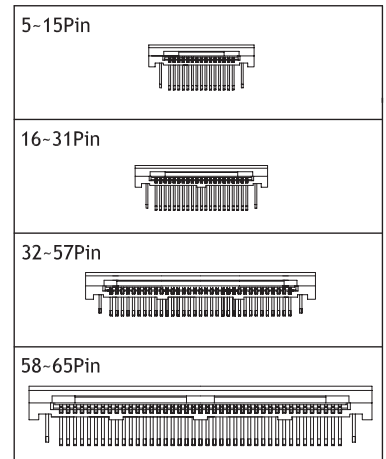
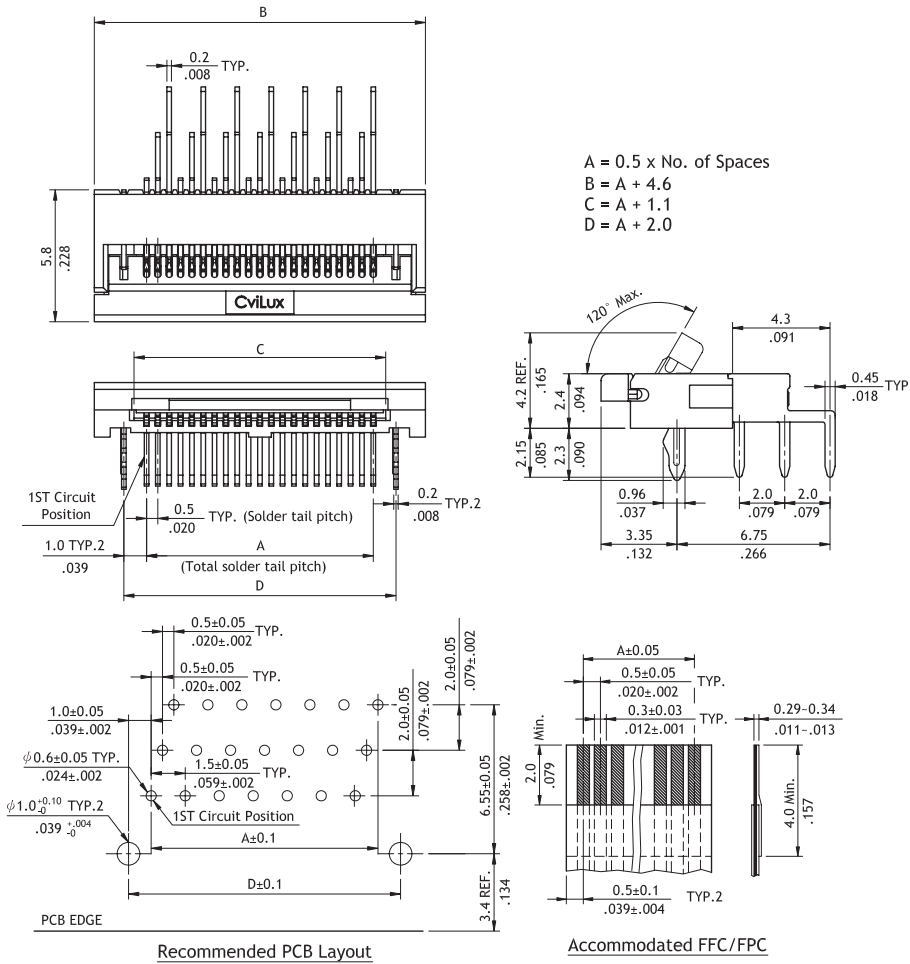

Ordering Code		①	②	③	④	⑤	⑥	⑦	⑧	⑨
		CF25	32	1	H	0	T	0	- 10 -	NH
① Series No.	② No. of Circuits: 04 ~ 32 *Circuits not found above please consult manufacturer*	③ Plating Code: 1 = Matte Tin over Nickel 2 = Gold flash over Nickel	④ Contact Style: H = Right Angle DIP Type (Downside Contact)	⑤ Color: 0 = Nature	⑥ Packing : T = Tube	⑦ Other Options: 0 = Standard *Special option consult manufacturer	⑧ Pitch: 10 = 1.00 mm	⑨ NH = For Lead Free IR process and Halogen-Free		

**CF11 Series 0.50mm(.039")H=2.70 SMT ZIF FFC/FPC Connectors (Back Flip actuator)**

- ⊙ 2.7mm above the board
- ⊙ Copper alloy dual contacts
- ⊙ Insulator: High temperature plastic UL 94V-0, Color Black
- ⊙ Cover: High temperature plastic UL 94V-0, Color Black
- ⊙ With metal fixed tabs to secure connector in place

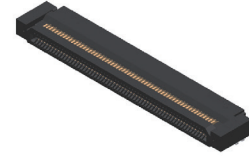

RoHS Compliant

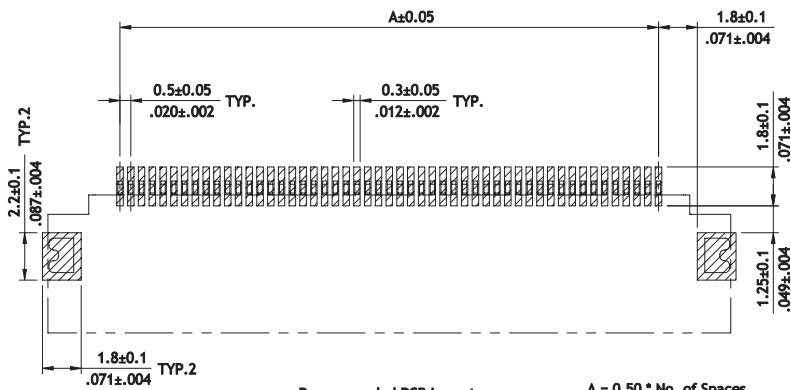
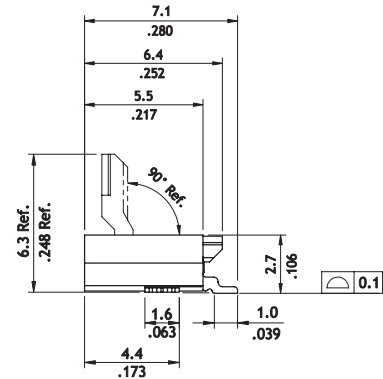
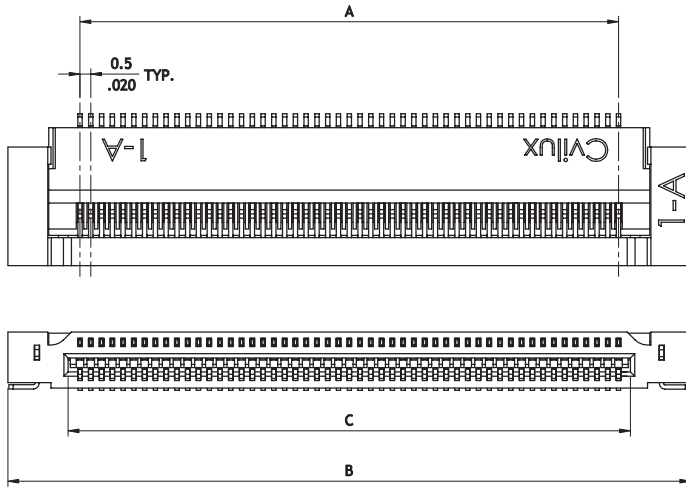

Recommended PCB Layout

A = 0.50 \* No. of Spaces  
 B = A + 6.7  
 C = A + 1.1

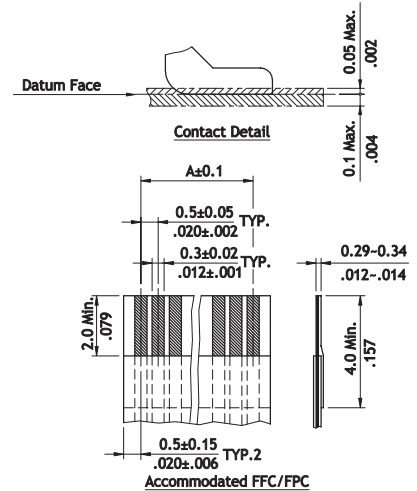

**Ordering Code**

① ② ③ ④ ⑤ ⑥ ⑦ ⑧ ⑨  
**C F 1 1   5 1   2   D   1   R   A   -   0 5   -   N H**

- ① Series No.
- ② No. of Circuits: 04 ~ 60  
 (Available: 5,8,20,26, 41,45,50,51)  
 \*Circuits not found above please consult manufacturer\*

- ③ Plating Code:  
 2 = Gold flash over Nickel
- ④ Contact Style:  
 D = Downside Contact
- ⑤ Color: 1 = Black
- ⑥ Packing: R = Tape & Reel  
 T = Tube

- ⑦ Other Options: A = Standard
- ⑧ Pitch: 05 = 0.50 mm
- ⑨ NH = For Lead Free IR process and Halogen-Free

**CF11 Series 1.00mm(.039")H=2.70 SMT ZIF FFC/FPC Connectors (Back Flip actuator)**

CF

- ⊙ 2.7mm above the board
- ⊙ Copper alloy dual contacts
- ⊙ Insulator: High temperature plastic UL 94V-0, Color Nature
- ⊙ Cover: High temperature plastic UL 94V-0, Color Black
- ⊙ With metal fixed tabs to secure connector in place

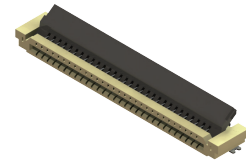

RoHS Compliant

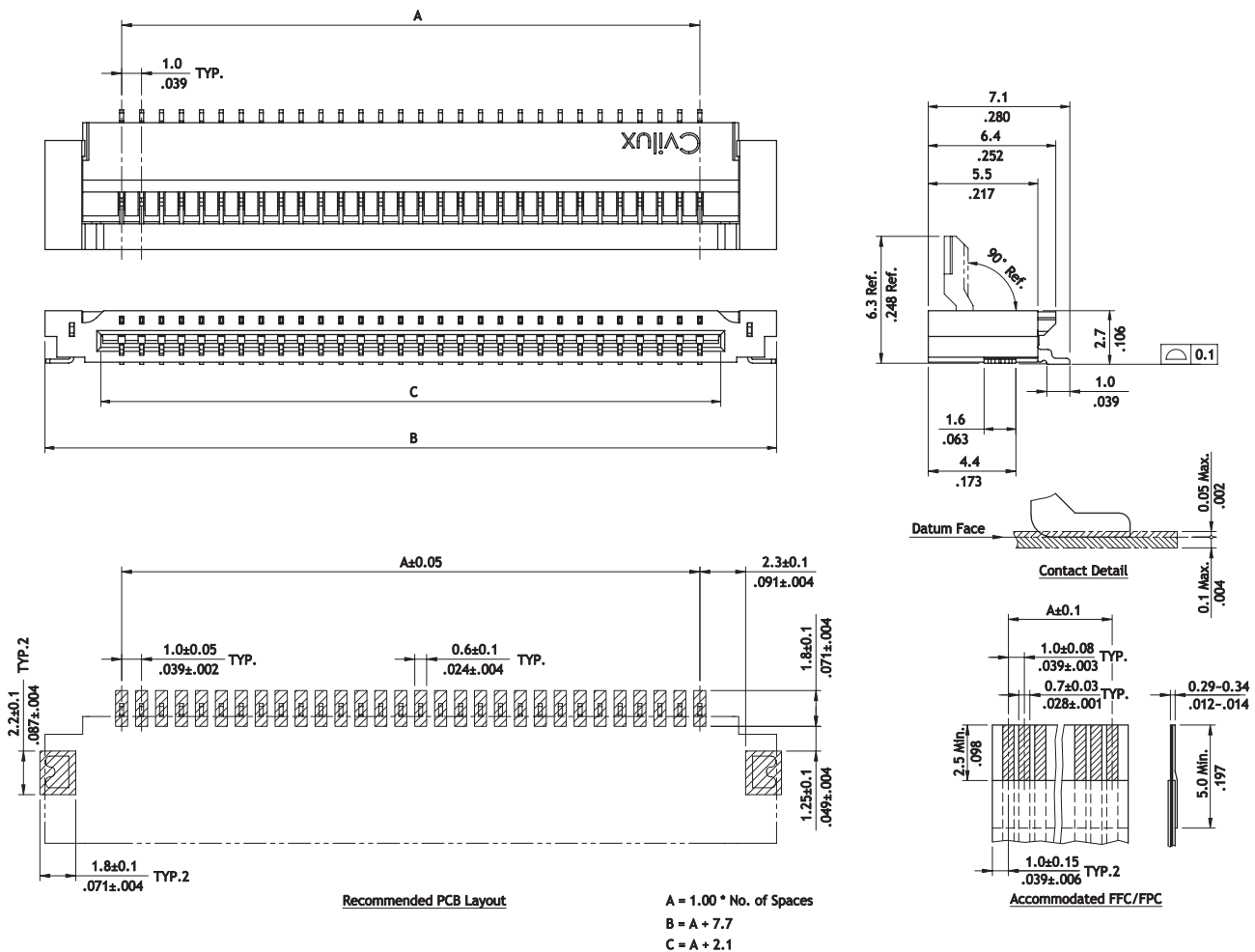

**Ordering Code**

① ② ③ ④ ⑤ ⑥ ⑦ ⑧ ⑨  
**CF11 30 2 D 0 R A - 10 - NH**

① Series No.  
 ② No. of Circuits: 04 ~ 30  
 (Available: 8,30)  
 \*Circuits not found above please consult manufacturer\*

③ Plating Code:  
 2 = Gold flash over Nickel  
 ④ Contact Style:  
 D = Downside Contact  
 ⑤ Color: 0 = Nature  
 ⑥ Packing: R = Tape & Reel  
 T = Tube

⑦ Other Options: A = Standard  
 ⑧ Pitch: 10 = 1.00 mm  
 ⑨ NH = For Lead Free IR process and Halogen-Free

**CF11 Series 1.00mm(.039")H=2.70 SMT ZIF FFC/FPC Connectors (Back Flip actuator)**

- ⊙ 2.7mm above the board
- ⊙ Copper alloy dual contacts
- ⊙ Insulator: High temperature plastic UL 94V-0, Color Nature
- ⊙ Cover: High temperature plastic UL 94V-0, Color Black
- ⊙ With metal fixed tabs to secure connector in place

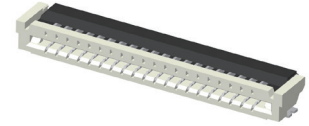

RoHS Compliant  

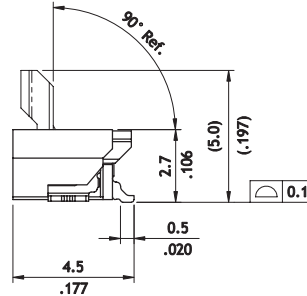
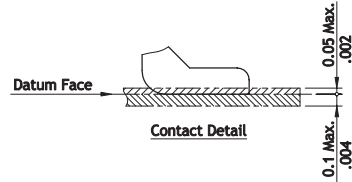
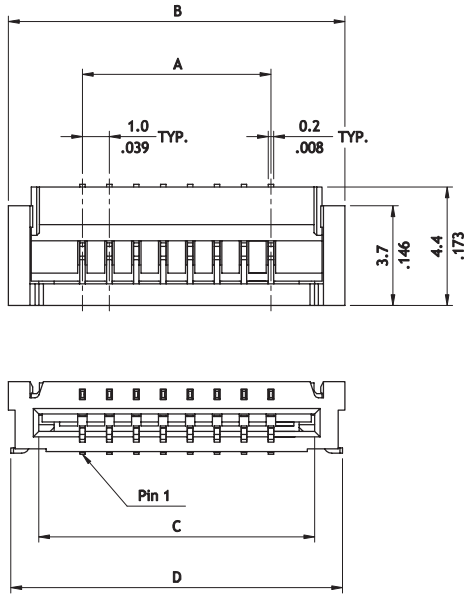

A = 1.0 \* No. of Spaces  
 B = A + 5.5  
 C = A + 3.25  
 D = A + 5.3

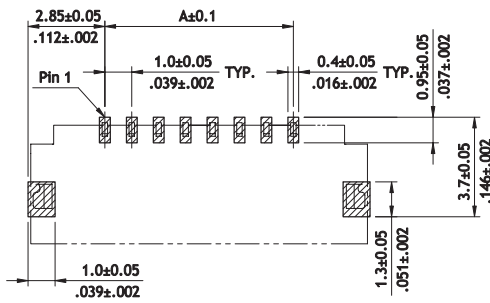

Recommended PCB Layout

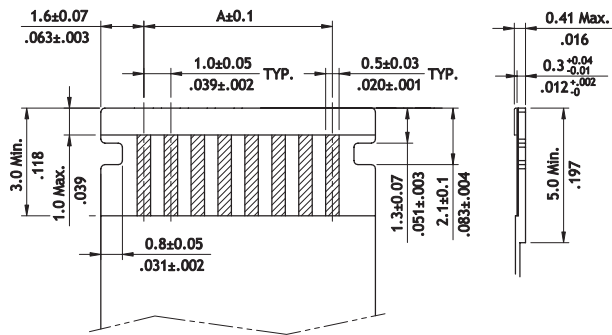

Accommodated FFC/FPC

**Ordering Code**

① ② ③ ④ ⑤ ⑥ ⑦ ⑧ ⑨  
**CF11 08 1 D 0 R C - 10 - NH**

- ① Series No.
- ② No. of Circuits: 04 ~ 20 (Available: 8/10/15)  
\*Circuits not found above please consult manufacturer\*

- ③ Plating Code:  
1= Matte Tin over Nickel
- ④ Contact Style: D = Downside Contact
- ⑤ Color: 0 = Nature
- ⑥ Packing: R = Tape & Reel  
T = Tube

- ⑦ Other Options: C = Type C  
\*Special option consult manufacturer
- ⑧ Pitch: 10 = 1.00 mm
- ⑨ NH = For Lead Free IR process and Halogen-Free

**CF23 Series 0.50mm(.020") H=1.20 SMT ZIF FFC/FPC Connectors**

CF

- ⊙ 1.2mm above the board
- ⊙ Insulator: High temperature plastic UL 94V-0, Color Nature
- ⊙ Slider: High temperature plastic UL 94V-0, Color Black
- ⊙ Fully checked by CCD and Hi-Pot test
- ⊙ With metal fixed tabs to secure connector in place

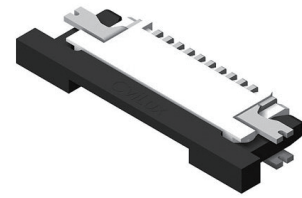

RoHS Compliant

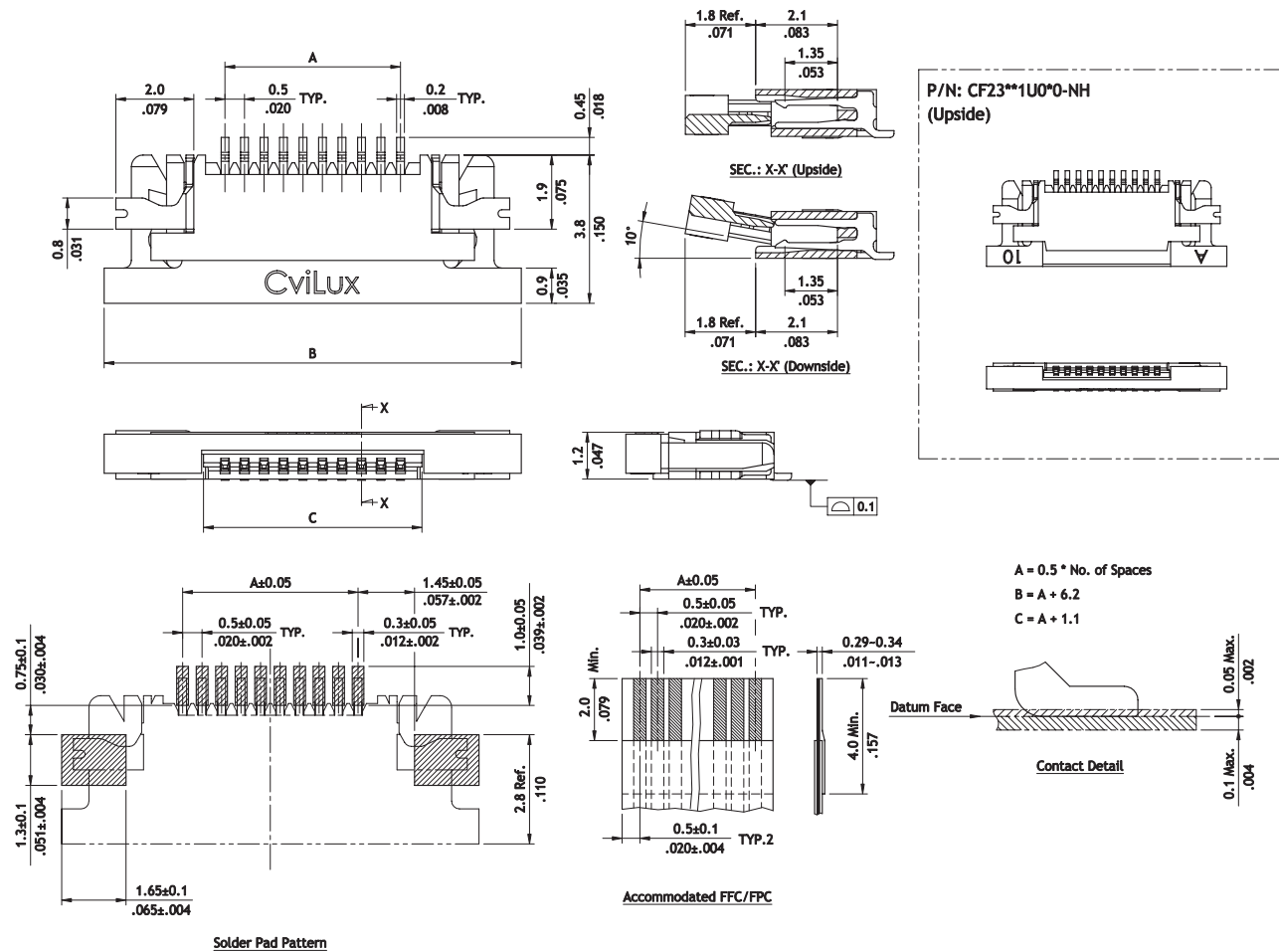

Ordering Code	①	②	③	④	⑤	⑥	⑦	⑧
	CF23	40	1	U	0	R	0	-NH
① Series No.								
② No. of Circuits: 04 ~ 40 (Available: 4~40) *Circuits not found above please consult manufacturer*								
③ Plating Code: 1 = Matte Tin over Nickel								
④ Contact Style: U = Upside Contact D = Downside Contact								
⑤ Color: 0 = Nature								
⑥ Packing: R = Tape & Reel T = Tube								
⑦ Other Options: 0 = Standard * Special options consult manufacturer								
⑧ NH = For Lead Free IR process and Halogen-Free								

FFC & FPC CONNECTOR

**CF23 Series 1.00mm(.039") H=1.20 SMT ZIF FFC/FPC Connectors**

- ⊙ 1.2mm above the board
- ⊙ Insulator: High temperature plastic UL 94V-0, Color Nature
- ⊙ Slider: High temperature plastic UL 94V-0, Color Black
- ⊙ Fully checked by CCD and Hi-Pot test
- ⊙ With metal fixed tabs to secure connector in place

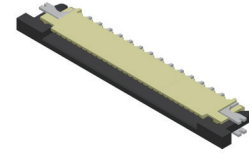

RoHS Compliant

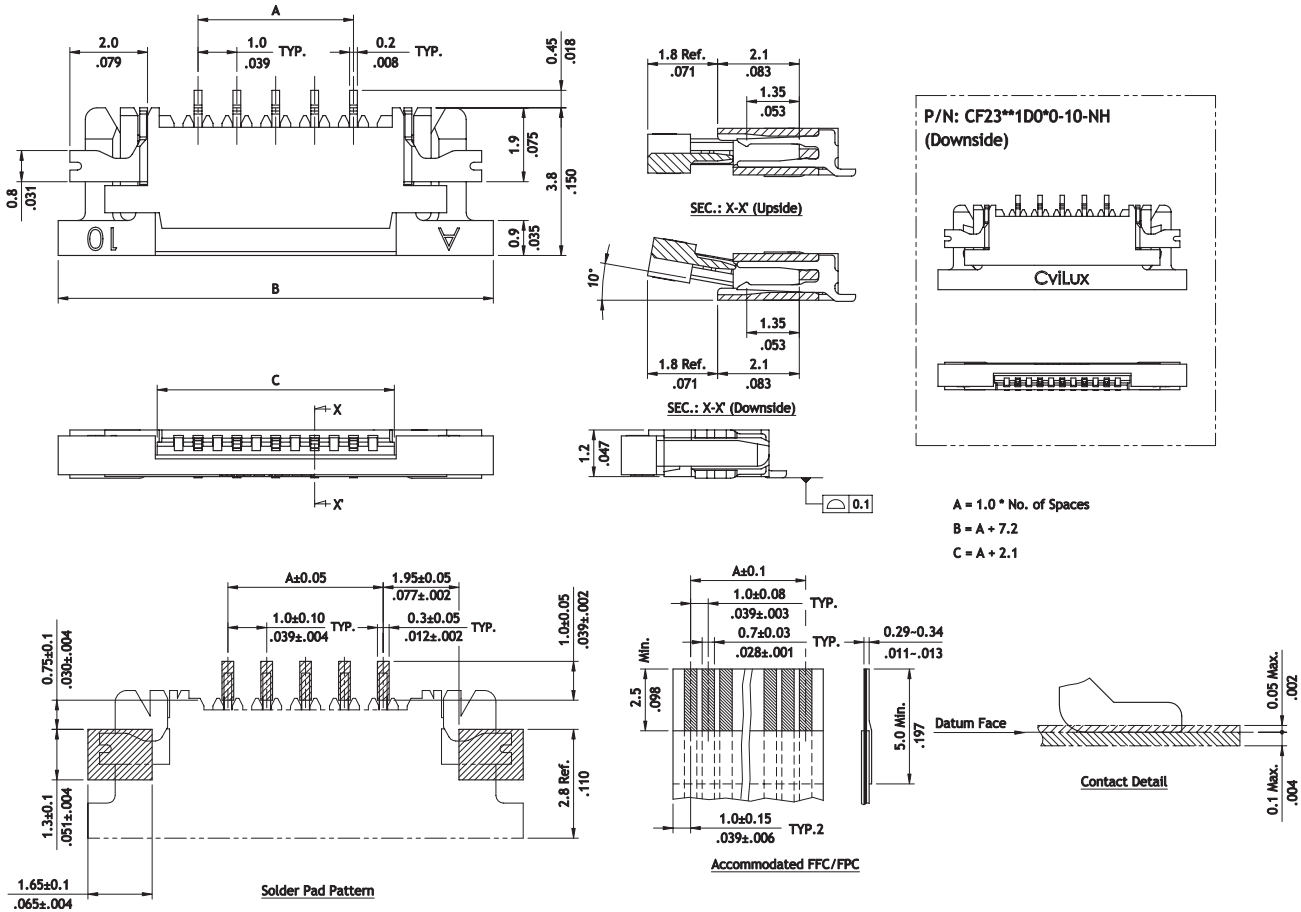

**Ordering Code**

① ② ③ ④ ⑤ ⑥ ⑦ ⑧ ⑨  
**CF23 19 1 U 0 R 0 - 10 - NH**

① Series No.  
 ② No. of Circuits: 03 ~ 19  
 \*Circuits not found above please consult manufacturer\*

③ Plating Code:  
 1 = Matte Tin over Nickel  
 ④ Contact Style:  
 U = Upside Contact  
 D = Downside Contact  
 ⑤ Color: 0 = Nature  
 ⑥ Packing: R = Tape & Reel  
 T = Tube

⑦ Other Options: 0 = Standard  
 \*Special option consult manufacturer  
 ⑧ Pitch: 10 = 1.00 mm  
 ⑨ NH = For Lead Free IR process and Halogen-Free

**CF20 Series 0.50mm(.020") H=2.00 SMT ZIF FFC/FPC Connectors**

CF

- ⊙ 2.00 mm above the board
- ⊙ Insulator: High temperature plastic UL 94V-0, Color Nature
- ⊙ Slider: High temperature plastic UL 94V-0, Color Black
- ⊙ With metal fixed tabs to secure connector in place

RoHS Compliant

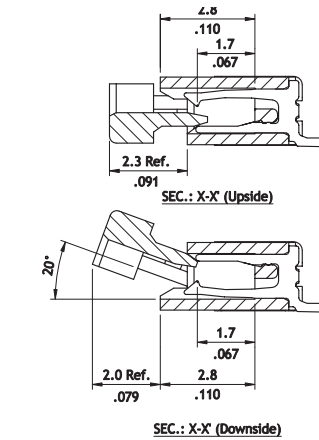
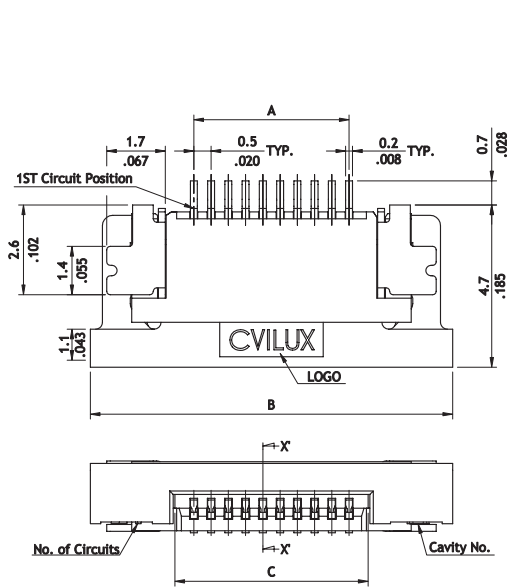
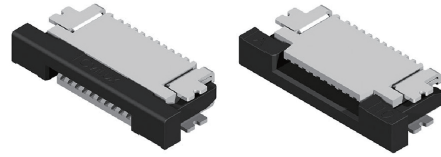

A = 0.5 \* No. of Spaces  
B = A + 6.0  
C = A + 1.1

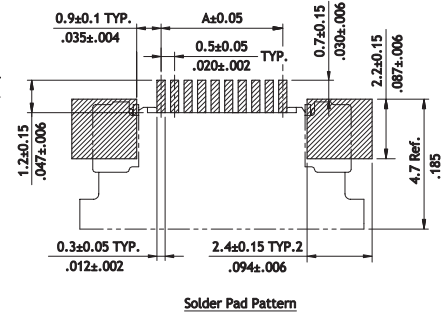
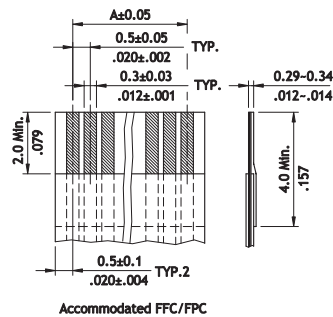
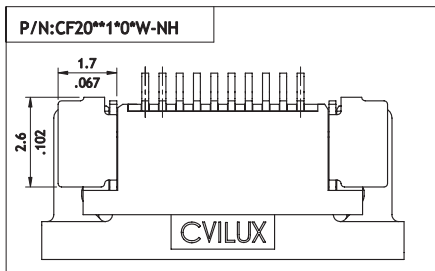
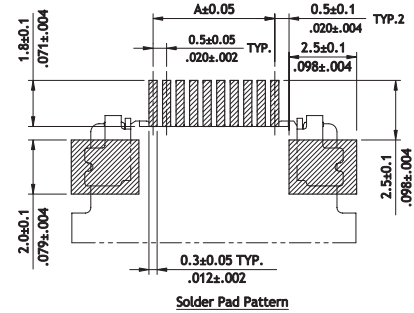

**Ordering Code**

① ② ③ ④ ⑤ ⑥ ⑦ ⑧  
**CF20 55 1 D 0 R 0 - NH**

- ① Series No.
- ② No. of Circuits: 04 ~ 55
- ③ Plating Code:  
1 = Matte Tin over Nickel  
2 = Gold flash over Nickel
- ④ Contact Style:  
U = Upside Contact  
D = Downside Contact
- ⑤ Color: 0 = Nature
- ⑥ Packing: R = Tape & Reel  
T = Tube
- ⑦ Other Options:  
0 = Standard  
W = Wide tabs  
\* Special options consult manufacturer
- ⑧ NH = For Lead Free IR process and Halogen-Free

CF20 Series 0.50mm(.020") H=3.90 SMT ZIF Vertical FFC/FPC Connectors

- ⊙ 3.9mm above the board
- ⊙ Insulator: High temperature plastic UL 94V-0, Color Nature
- ⊙ Slider: High temperature plastic UL 94V-0, Color Black
- ⊙ With metal fixed tabs to secure connector in place

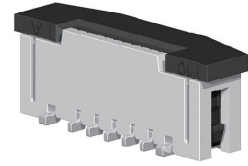

RoHS Compliant

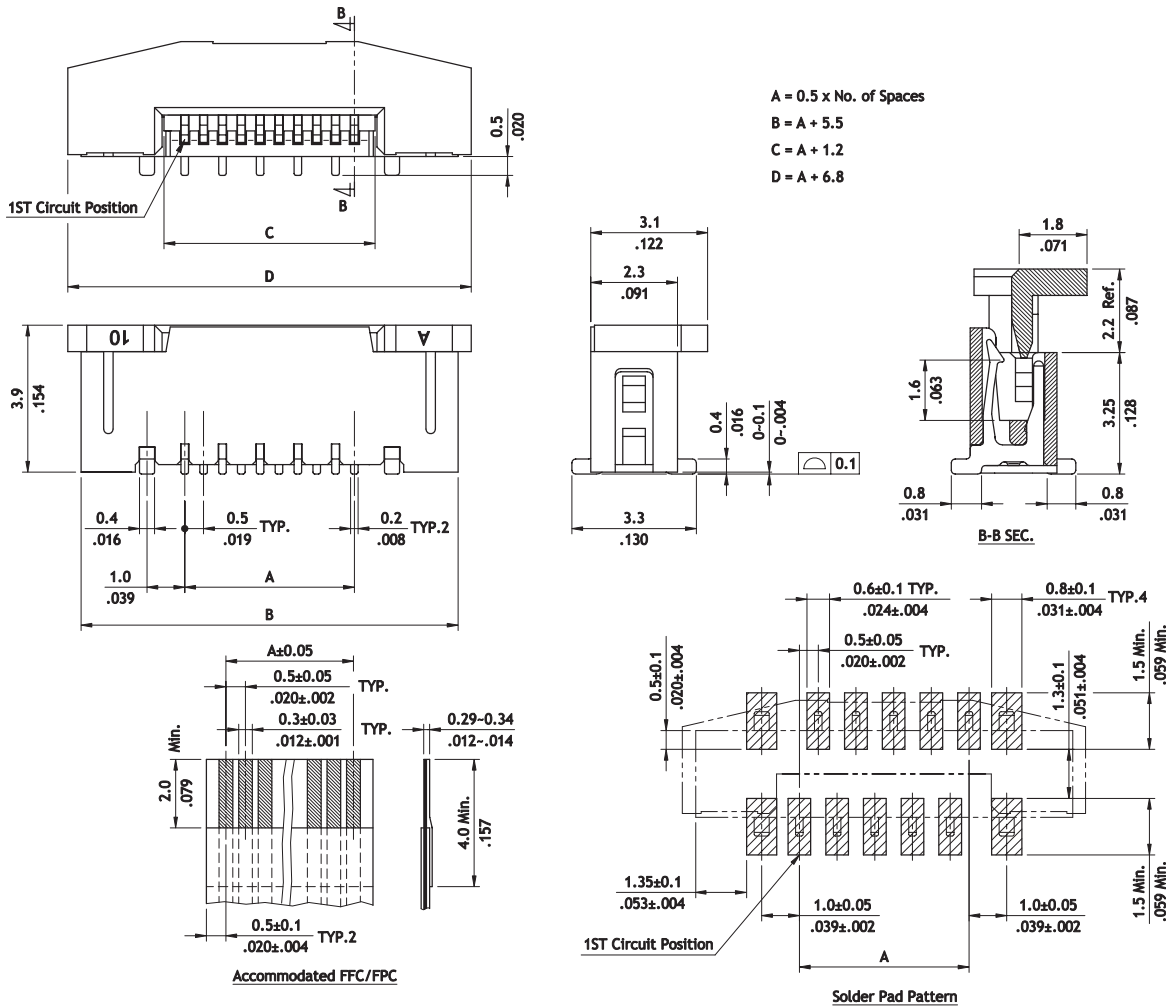

Ordering Code

① ② ③ ④ ⑤ ⑥ ⑦ ⑧  
**CF20 55 1 V 0 R 0 - NH**

- ① Series No.
- ② No. of Circuits: 04 ~ 55
- ③ Plating Code:  
1 = Matte Tin over Nickel  
2 = Gold flash over Nickel
- ④ Contact Style:  
V = Vertical Type
- ⑤ Color: 0 = Nature
- ⑥ Packing: R = Tape & Reel  
T = Tube
- ⑦ Other Options: 0 = Standard  
\* Special options consult manufacturer
- ⑧ NH = For Lead Free IR process  
and Halogen-Free

**CF20 Series 1.00mm(.039") H=2.00 SMT ZIF FFC/FPC Connectors**

CF

- ⊙ Insulator: High temperature plastic UL 94V-0, Color Nature
- ⊙ Slider: High temperature plastic UL 94V-0, Color Black
- ⊙ With metal fixed tabs to secure connector in place

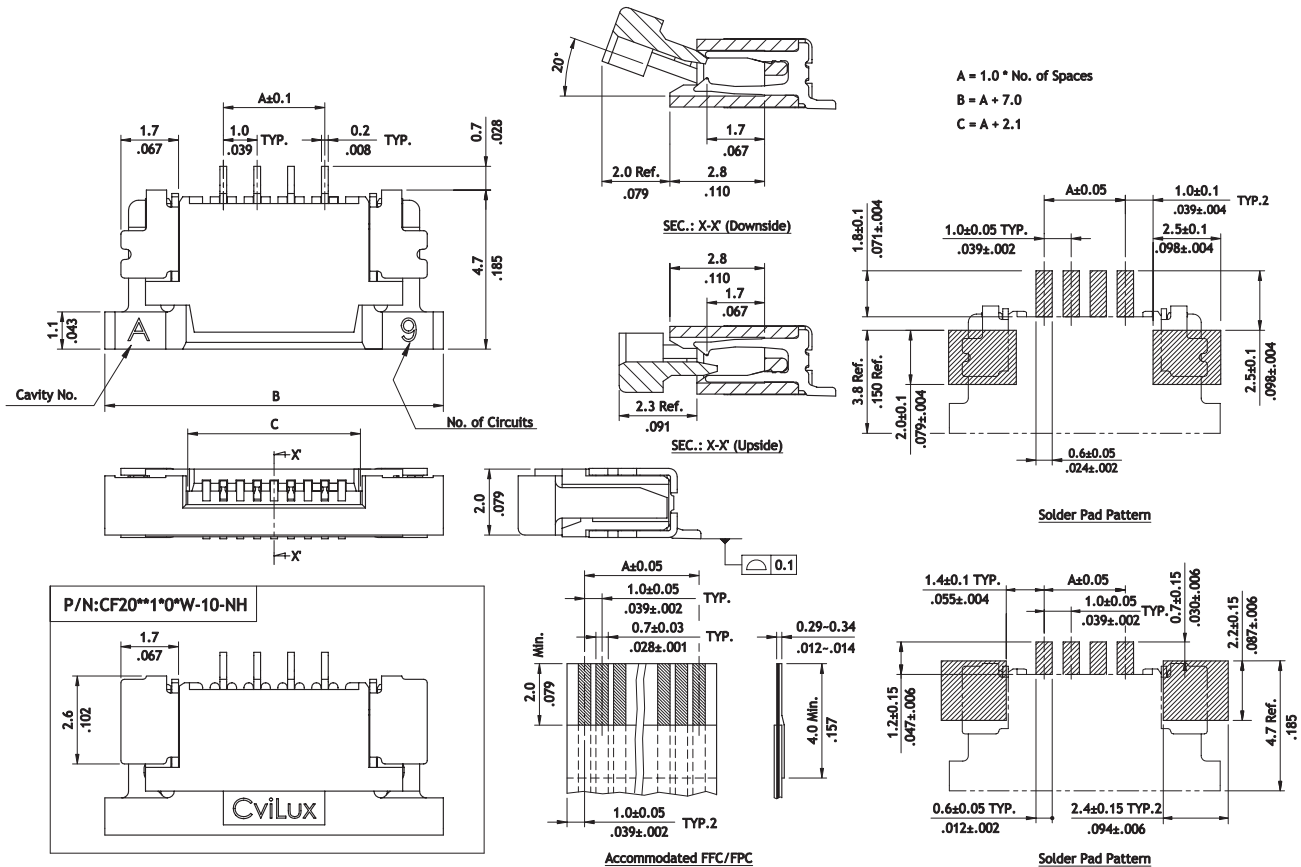
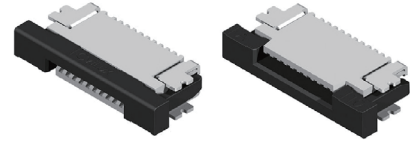

**Ordering Code**

① ② ③ ④ ⑤ ⑥ ⑦ ⑧ ⑨  
**CF20 27 1 U 0 R 0 - 10 - NH**

- ① Series No.
- ② No. of Circuits: 04 ~ 27
- ③ Plating Code:  
 1 = Matte Tin over Nickel  
 2 = Gold flash over Nickel
- ④ Contact Style:  
 U = Upside Contact  
 D = Downside Contact
- ⑤ Color: 0 = Nature
- ⑥ Packing: R = Tape & Reel  
 T = Tube
- ⑦ Other Options:  
 0 = Standar  
 W = Wide Tabs  
 \*Special option consult manufacturer
- ⑧ Pitch: 10 = 1.00 mm
- ⑨ NH = For Lead Free IR process and Halogen-Free

CF27 Series 0.50mm(.020") H=1.20 SMT LIF FFC/FPC Connectors

- ⊙ 1.2mm above the board
- ⊙ Copper alloy dual contacts
- ⊙ Insulator: High temperature plastic UL 94V-0, Color Nature
- ⊙ With metal fixed tabs to secure connector in place

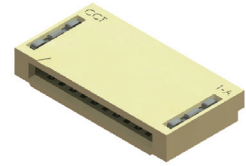

RoHS Compliant

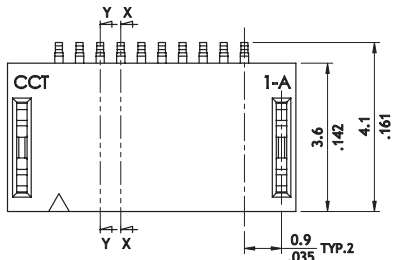

A = 0.5 x No. of Spaces  
 B = A + 2.5  
 C = A + 1.0  
 D = A + 4.5

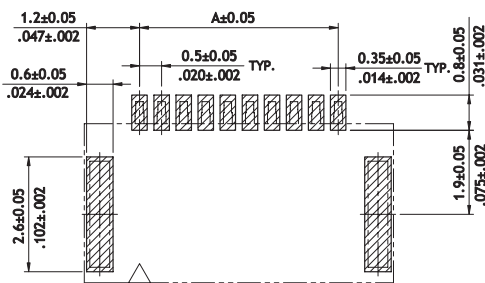
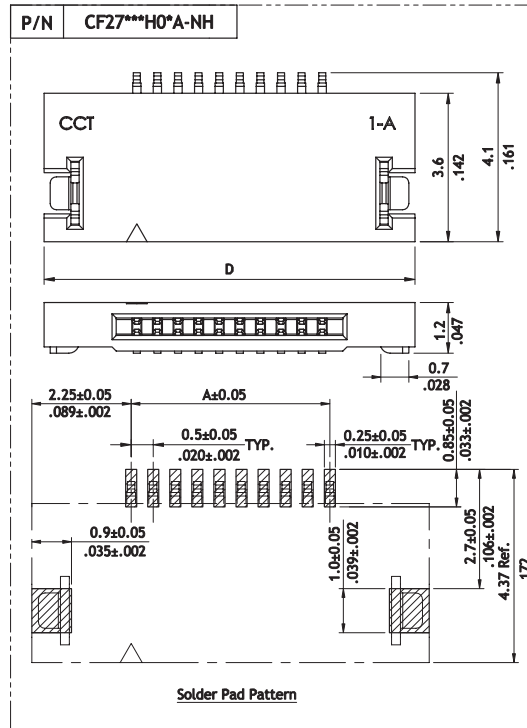
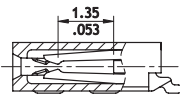
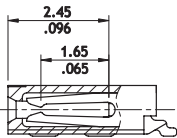
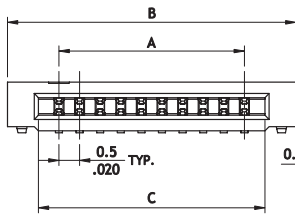

Solder Pad Pattern

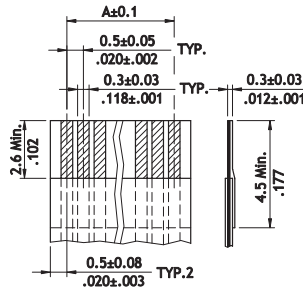

Accommodated FFC

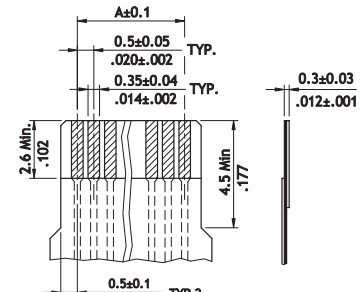

Accommodated FPC

Ordering Code

① ② ③ ④ ⑤ ⑥ ⑦ ⑧  
**CF27 20 1 H 0 R 0 - NH**

- ① Series No.
- ② No. of Circuits: 04 ~ 20
- ③ Plating Code:  
 1 = Matte Tin over Nickel  
 2 = Gold flash over Nickel

- ④ Contact Style:  
 H = Side Entry
- ⑤ Color: 0 = Nature
- ⑥ Packing: R = Tape & Reel  
 T = Tube

- ⑦ Other Options:  
 0 = Standard  
 A = Base of Wide size
- ⑧ NH = For Lead Free IR process and Halogen-Free

**CF27 Series 1.00mm(.039") H=1.20 SMT LIF FFC/FPC Connectors**

CF

- ⊙ 1.2mm above the board
- ⊙ Copper alloy dual contacts
- ⊙ Insulator: High temperature plastic UL 94V-0, Color Nature
- ⊙ With metal fixed tabs to secure connector in place

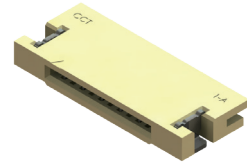

RoHS Compliant

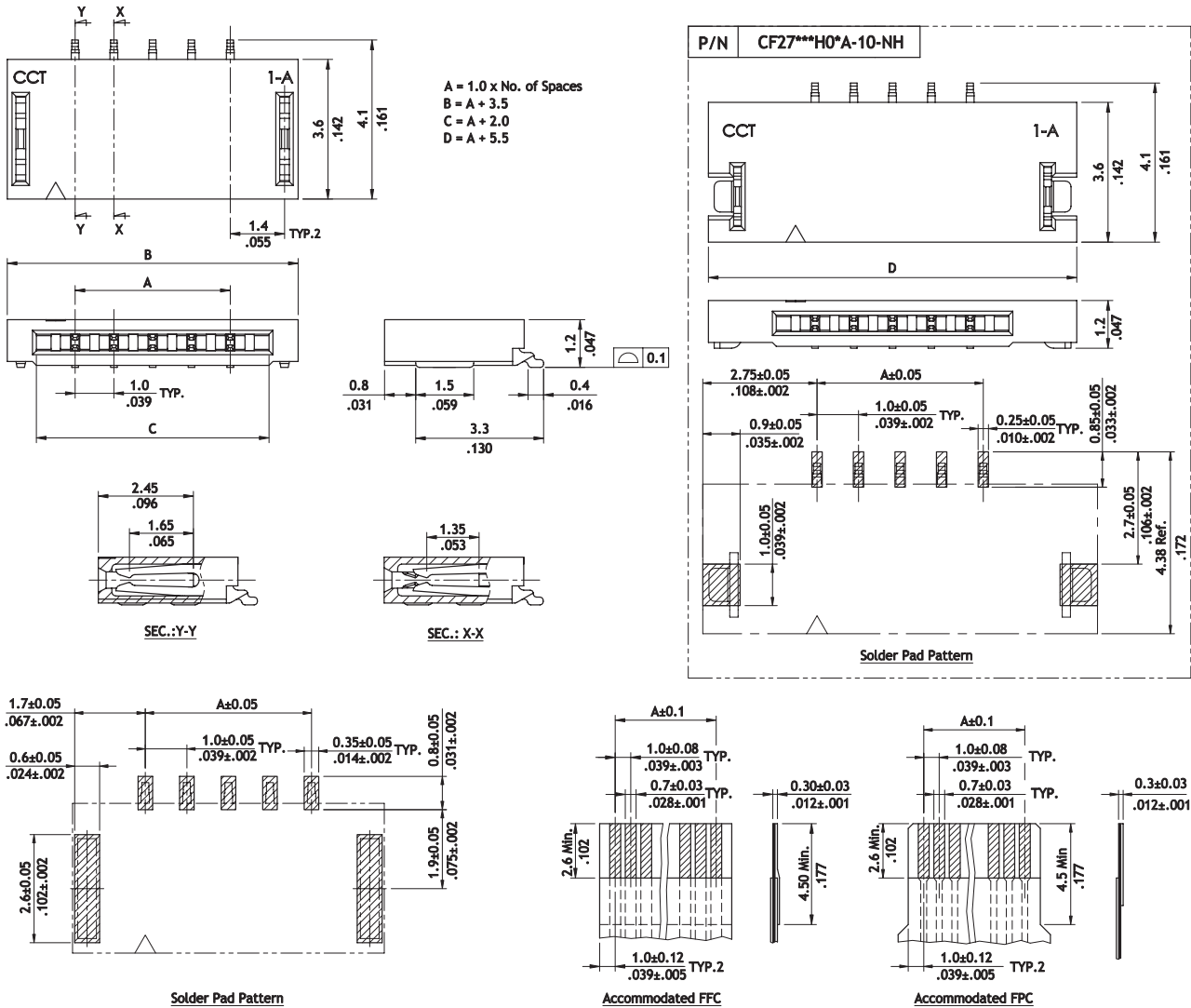

**Ordering Code**

① ② ③ ④ ⑤ ⑥ ⑦ ⑧ ⑨  
**CF27 10 1 H 0 R 0 - 10 - NH**

- ① Series No.
- ② No. of Circuits: 04 ~ 10
- ③ Plating Code:  
 1 = Matte Tin over Nickel  
 2 = Gold flash over Nickel
- ④ Contact Style: H = Side Entry
- ⑤ Color: 0 = Nature
- ⑥ Packing: R = Tape & Reel  
 T = Tube
- ⑦ Other Options:  
 0 = Standard  
 A = Base of Wide size
- ⑧ Pitch: 10 = 1.00 mm
- ⑨ NH = For Lead Free IR process and Halogen-Free

FFC & FPC CONNECTOR

**CF24 Series 0.50mm(.020") H=4.20 SMT LIF Vertical FFC/FPC Connectors**

- ⊙ Tin plated over copper alloy dual contacts
- ⊙ Insulator: High temperature plastic UL 94V-0, Color Nature
- ⊙ Low insertion force

RoHS Compliant 

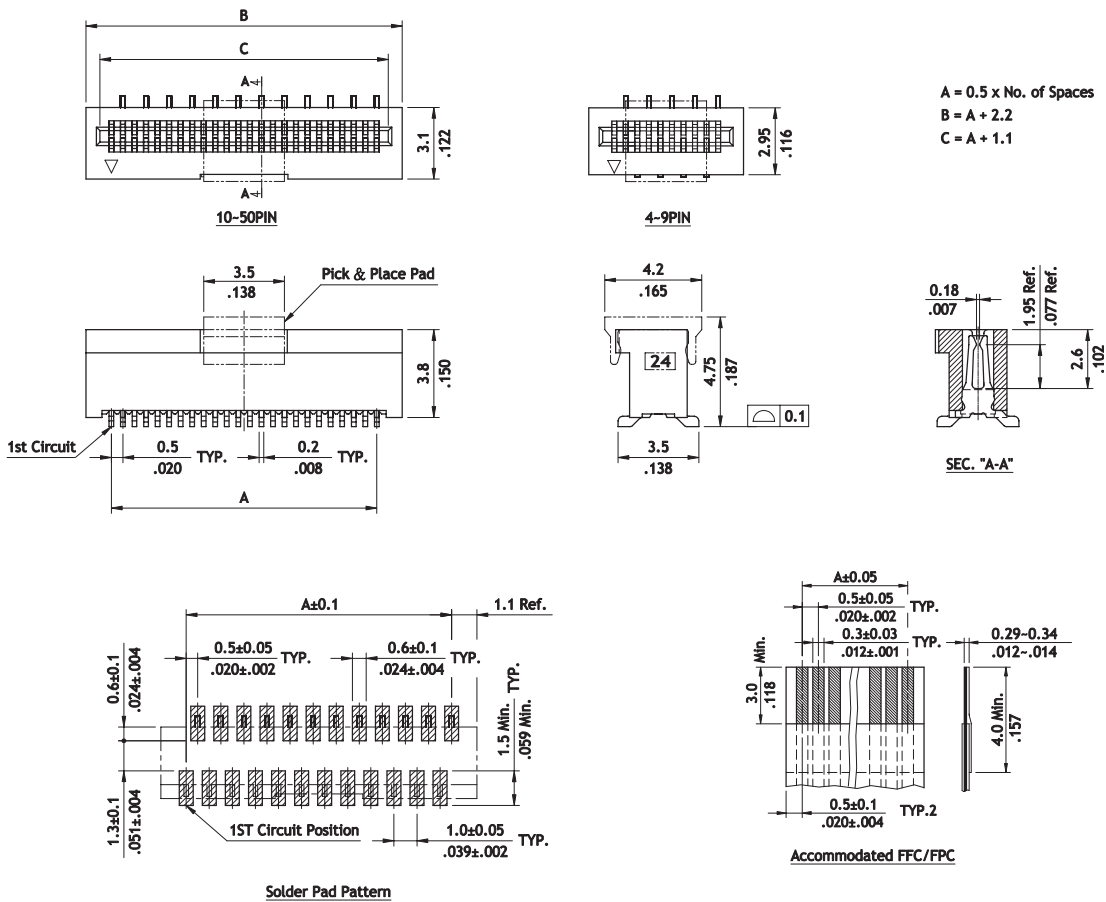
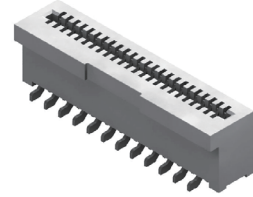

A = 0.5 x No. of Spaces  
 B = A + 2.2  
 C = A + 1.1

**Ordering Code**

① ② ③ ④ ⑤ ⑥ ⑦ ⑧  
**CF24 50 1 V 0 R 0 - NH**

- ① Series No.
- ② No. of Circuits: 04 ~50
- ③ Plating Code:  
1 = Matte Tin over Nickel
- ④ Contact Style:  
V = Vertical Type
- ⑤ Color: 0 = Nature
- ⑥ Packing:  
R = Tape & Reel  
T = Tube
- ⑦ Other Options:  
0 = With pick & place pad (Standard)  
N = Without pick & place pad  
\*Special options consult manufacturer
- ⑧ NH = For Lead Free IR process and Halogen-Free

**CFAB Series 0.50mm(.019") H=1.20 SMT ZIF FFC/FPC Connectors**

CF

- ⊙ 3.60mm above the board
- ⊙ FFC/FPC zero insertion force and high retention force
- ⊙ Insulator: High temperature plastic UL 94V-0, Color Nature
- ⊙ Cover : High temperature plastic UL 94V-0, Color Black
- ⊙ Actuator designed easy for FPC installation and reliable operation
- ⊙ With metal fixed tabs to secure connector in place

**NEW**

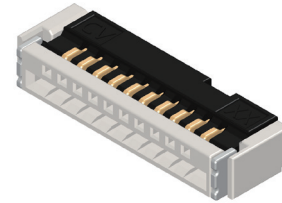

RoHS Compliant

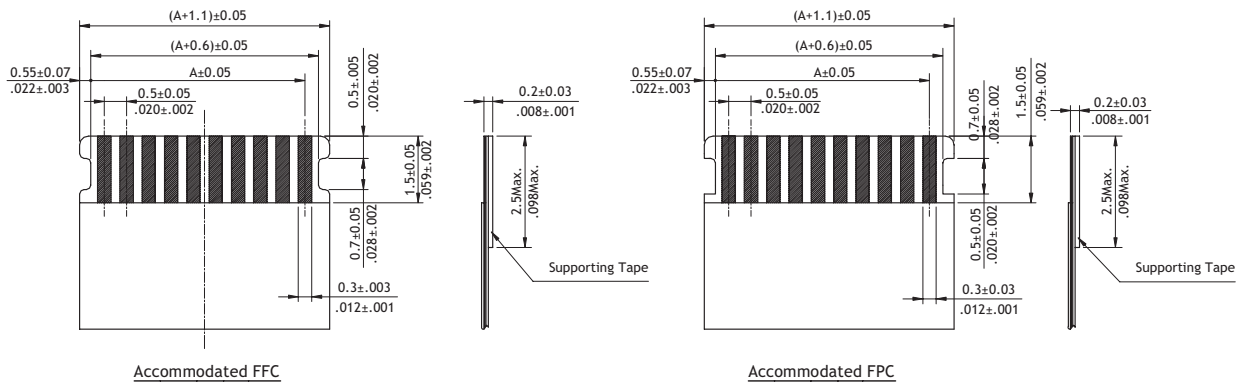
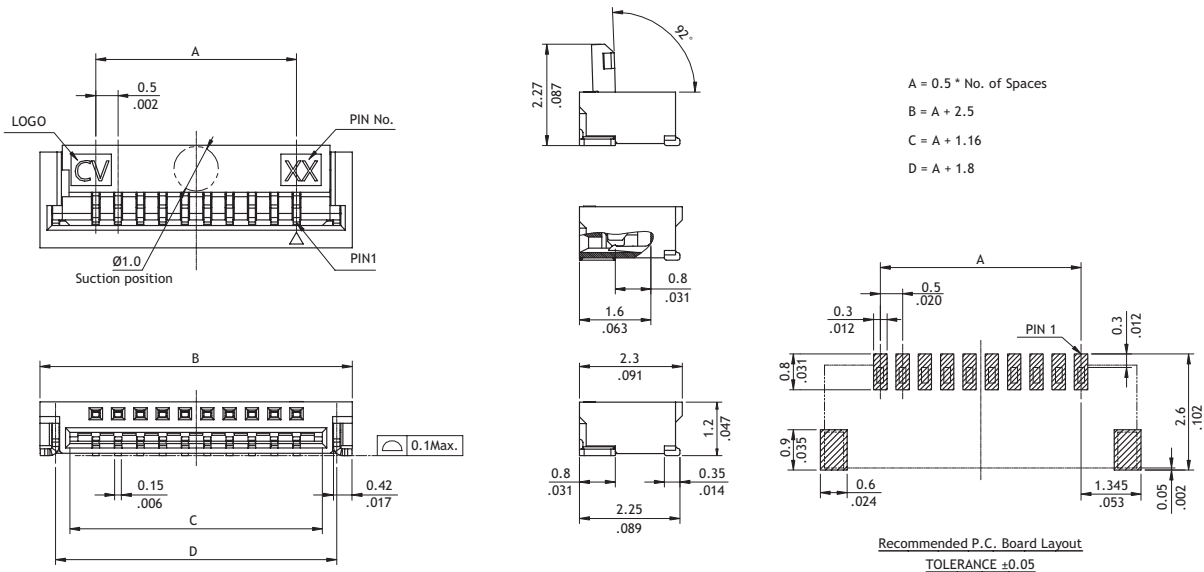

**Ordering Code**

① ② ③ ④ ⑤ ⑥ ⑦ ⑧ ⑨  
**CFAB 20 1 D 0 R 0 - 05 - NH**

- |   |   |   |
|---|---|---|
| <p>① Series No</p> <p>② No. of Circuits: 04 ~ 30<br/>*Circuits not found above please consult manufacturer*</p> <p>③ Plating Code:<br/>1 = Matte Tin over Nickel<br/>F = Gold flash over Nickel</p> | <p>④ Contact Style:<br/>D = Downside Contact</p> <p>⑤ Color: 0 = Nature</p> <p>⑥ Packing: R = Tape &amp; Reel</p> | <p>⑦ Other Options:<br/>0 = Standard</p> <p>⑧ Pitch: 05 = 0.50 mm</p> <p>⑨ NH = For Lead Free IR process and Halogen-Free</p> |
|---|---|---|

**CF95 Series 0.8mm(.031") H=1.50 SMT ZIF FFC/FPC Connectors (Back Flip actuator)**

- ⊙ 1.50mm above the board
- ⊙ FFC/FPC zero insertion force and high retention force
- ⊙ Insulator: High temperature plastic UL 94V-0, Color Nature
- ⊙ Cover : High temperature plastic UL 94V-0, Color Black
- ⊙ Actuator designed easy for FPC installation and reliable operation
- ⊙ With metal fixed tabs to secure connector in place



RoHS Compliant

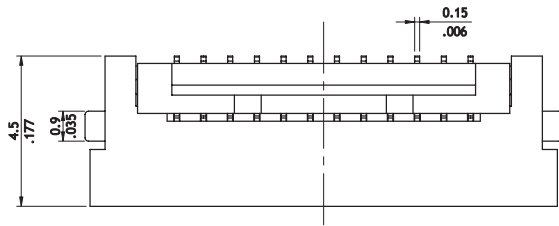

A = 0.8 \* No. of Spaces  
 B = A + 5.2  
 C = A + 2.45

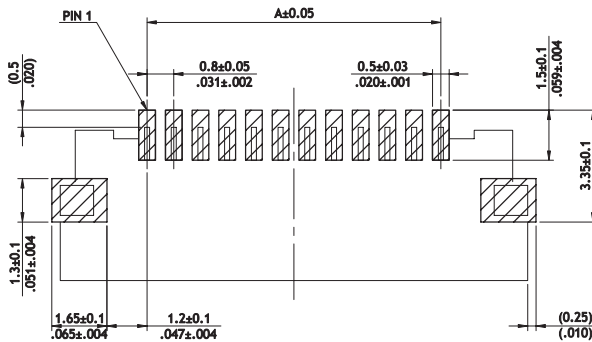
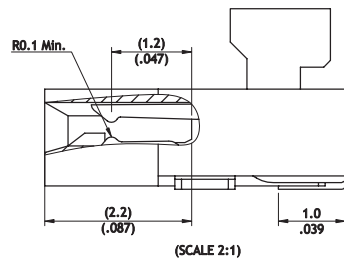
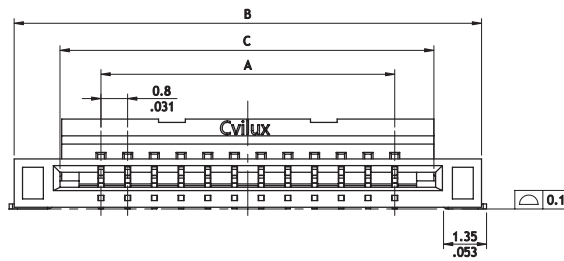
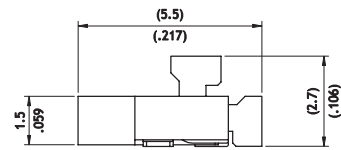

Recommended P.C. Board Layout

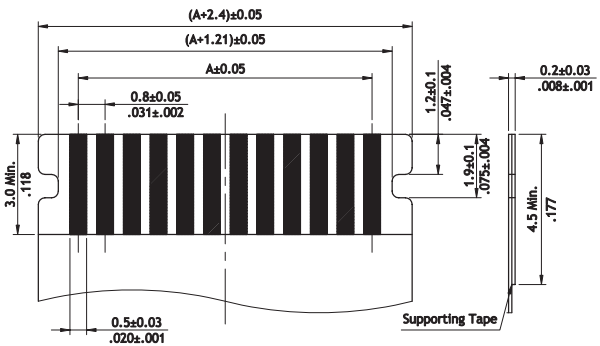

Accommodated FFC/FPC

**Ordering Code**

① ② ③ ④ ⑤ ⑥ ⑦ ⑧  
**CF95 30 1 H 0 R 0 - NH**

- ① Series No.
- ② No. of Circuits: 04 ~ 30
- ③ Plating Code:  
 1 = Matte Tin over Nickel  
 F = Gold flash over Nickel

- ④ Contact style :  
 H = Dual Side
- ⑤ Color : 0 = Nature

- ⑥ Packing : R = Tape & Reel
- ⑦ Options: 0 = Standard
- ⑧ NH = For Lead Free soldering process and Halogen-Free

**CF84 Series 0.8mm(.031") H=1.57 SMT ZIF FFC/FPC Connectors (Back Flip actuator)**

CF

- ⊙ 1.57mm above the board
- ⊙ FFC/FPC zero insertion force and high retention force
- ⊙ Insulator: High temperature plastic UL 94V-0, Color Nature
- ⊙ Cover : High temperature plastic UL 94V-0, Color Black
- ⊙ Actuator designed easy for FPC installation and reliable operation
- ⊙ With metal fixed tabs to secure connector in place

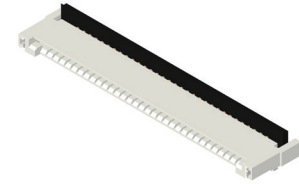

RoHS Compliant

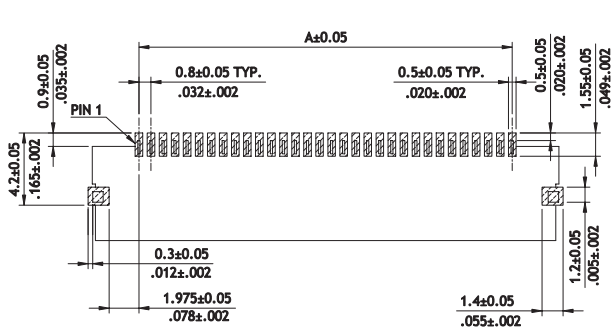
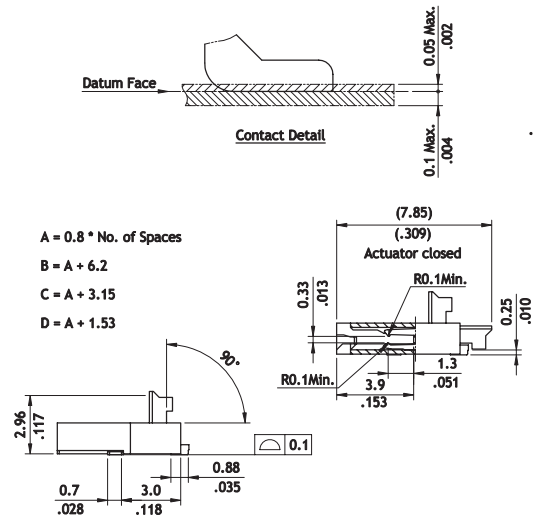
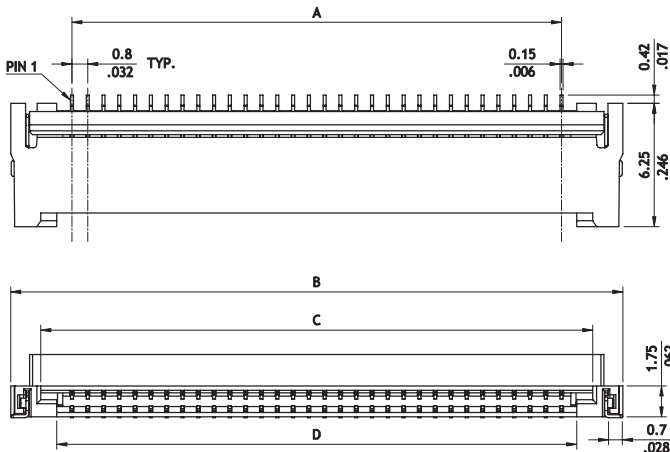

Recommended P.C. Board Layout

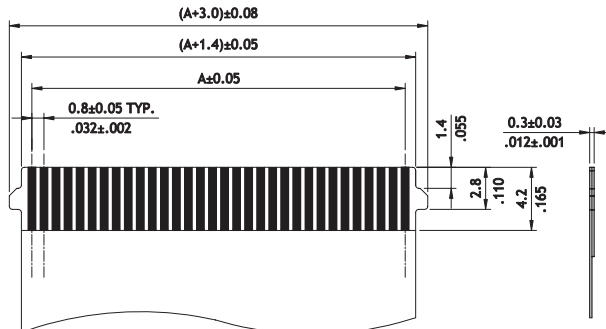

Accommodated FFC/FPC

**Ordering Code**

① ② ③ ④ ⑤ ⑥ ⑦  
**CF84 50 1 H 0 RA - NH**

- ① Series No.
- ② No. of Circuits: 04 ~ 50
- ③ Plating Code:  
1 = Matte Tin over Nickel  
F = Gold flash over Nickel
- ④ Contact style :  
H = Dual Side
- ⑤ Color : 0 = Nature
- ⑥ Packing : RA = Tape & Reel
- ⑦ NH = For Lead Free soldering process and Halogen-Free

**CF32 Series 0.80mm(.031")H=1.95 SMT ZIF One-Touch FFC/FPC Connectors**

- ⊙ 1.95mm above the board
- ⊙ FFC/FPC zero insertion force and high retention force
- ⊙ Insulation: High temperature plastic UL 94V-0, Color Nature
- ⊙ Cover: High temperature plastic UL 94V-0, Color Black
- ⊙ Actuator designed easy for FFC/FPC installation and reliable operation
- ⊙ With metal fixed tabs to secure connector in place

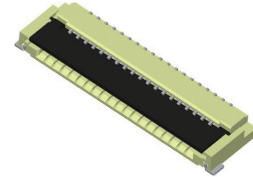

RoHS Compliant  

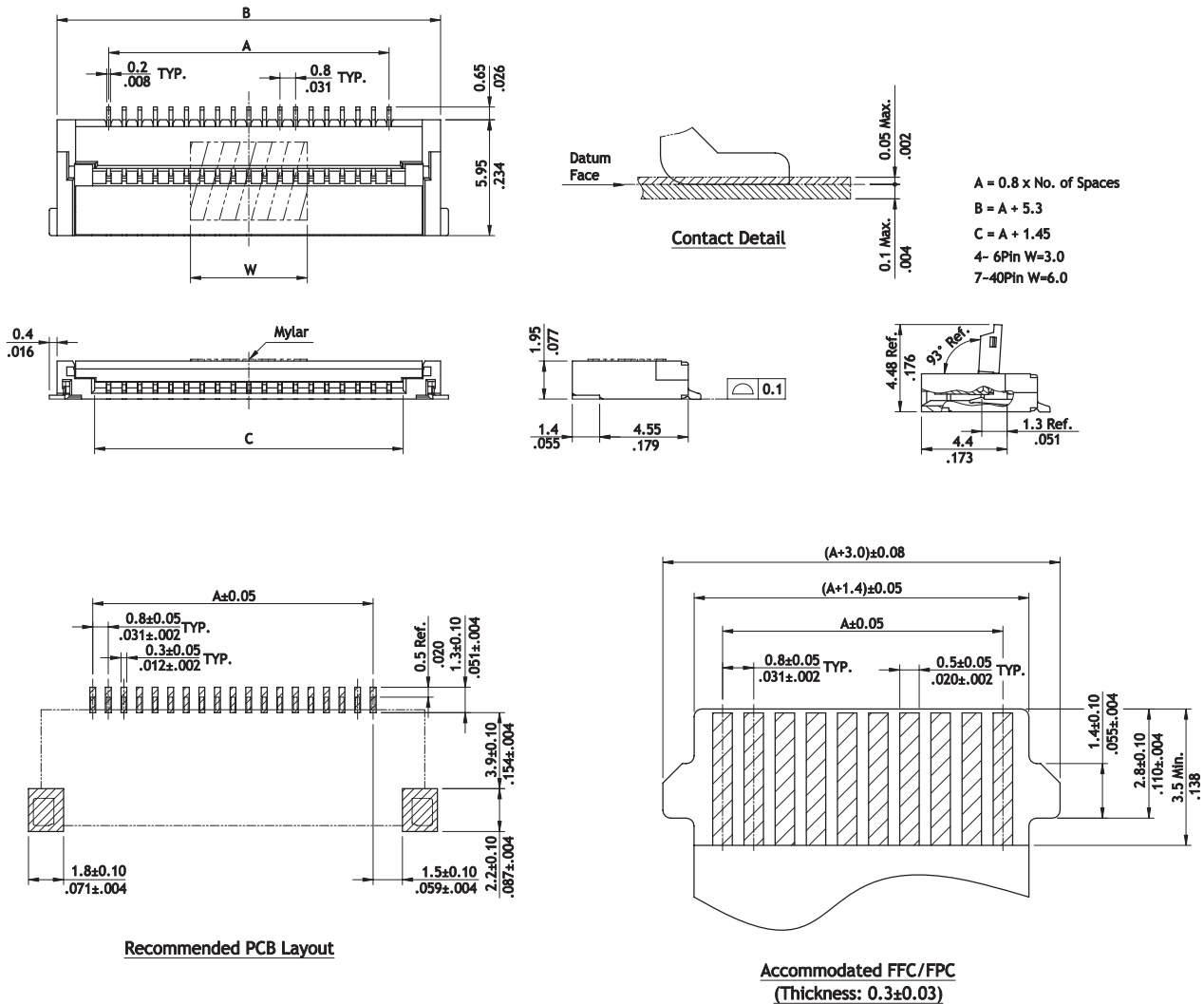

**Ordering Code**

① ② ③ ④ ⑤ ⑥ ⑦ ⑧  
**CF32 32 1 D 0 R 0 - NH**

- ① Series No.
- ② No. of Circuits: 04 ~ 40 (Available: 30,32)  
 \*Circuits not found above please consult manufacturer\*

- ③ Plating Code:  
 1 = Matte Tin over Nickel  
 2 = Gold flash over Nickel
- ④ Contact Style:  
 D = Downside contact
- ⑤ Color: 0 = Nature
- ⑥ Packing: R = Tape & Reel

- ⑦ Other Options:  
 0 = Without Mylar (Standard)  
 M = With Mylar  
 \*Special options consult manufacturer
- ⑧ NH = For Lead Free IR process and Halogen-Free

**CF37 Series 0.80mm(.031")H=1.95 SMT ZIF One-Touch FFC/FPC Connectors**

CF

- ⊙ 1.95mm above the board
- ⊙ FFC/FPC zero insertion force and high retention force
- ⊙ Insulation: High temperature plastic UL 94V-0, Color Nature
- ⊙ Cover: High temperature plastic UL 94V-0, Color Black
- ⊙ Actuator designed easy for FFC/FPC installation and reliable operation
- ⊙ With metal fixed tabs to secure connector in place

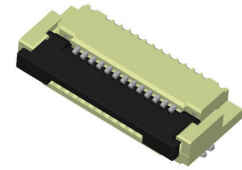

RoHS Compliant

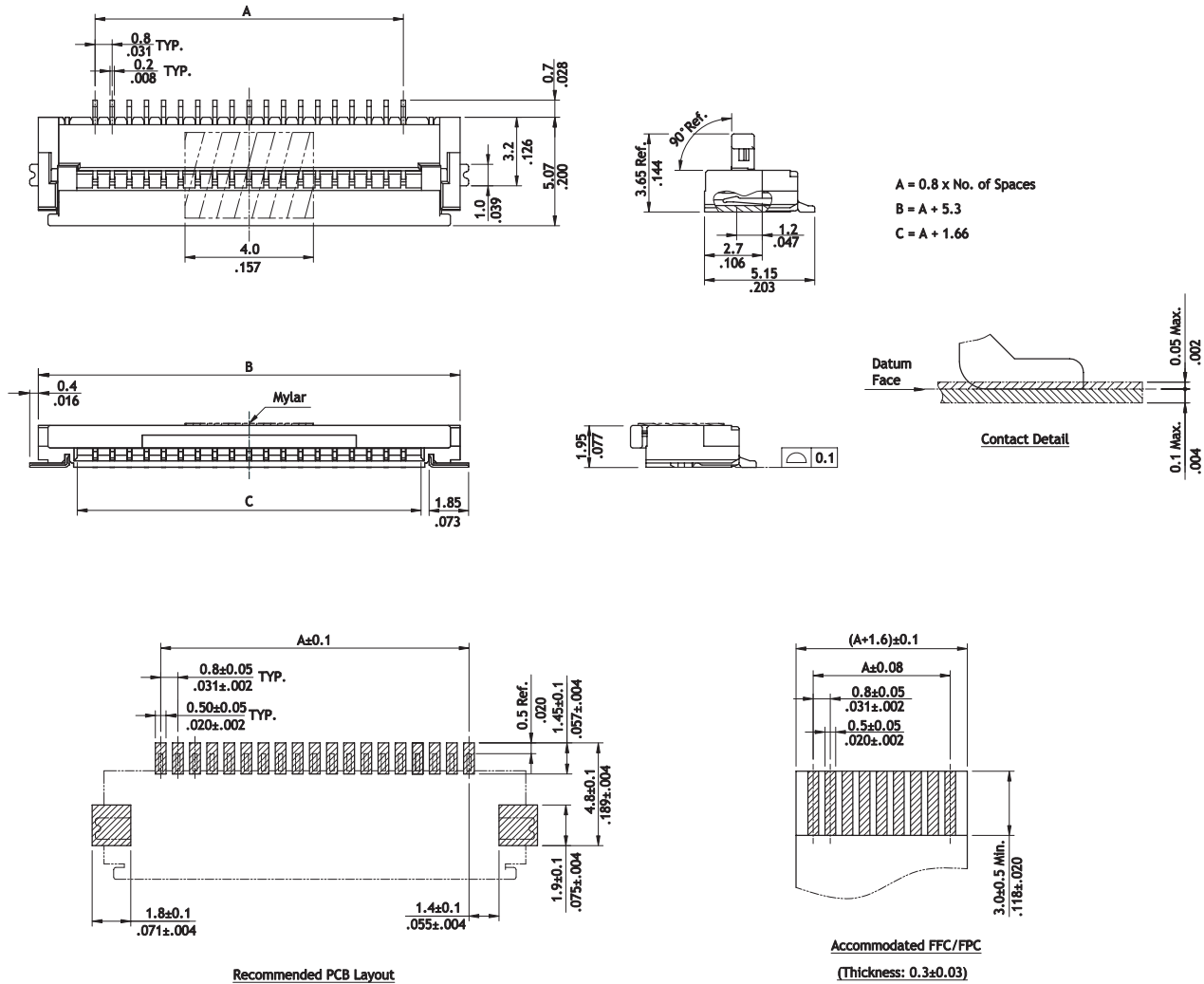

Ordering Code	①	②	③	④	⑤	⑥	⑦	⑧
	CF37	34	2	D	0	R	0	NH
① Series No.								
② No. of Circuits: 04 ~ 40 (Available: 26,34) *Circuits not found above please consult manufacturer*								
③ Plating Code: 1 = Matte Tin over Nickel 2 = Gold flash over Nickel								
④ Contact Style: D = Downside contact								
⑤ Color: 0 = Nature								
⑥ Packing: R = Tape & Reel								
⑦ Other Options: 0 = Without Mylar (Standard) M = With Mylar *Special options consult manufacturer								
⑧ NH = For Lead Free IR process and Halogen-Free								

**CF07 Series 1.00mm(.039") H=2.6 SMT ZIF FFC/FPC Connectors**

- ⊙ Insulator: High temperature plastic UL 94V-0, Color Nature
- ⊙ Cover : High temperature plastic UL 94V-0, Color Black
- ⊙ With metal fixed tabs to secure connector in place

RoHS Compliant

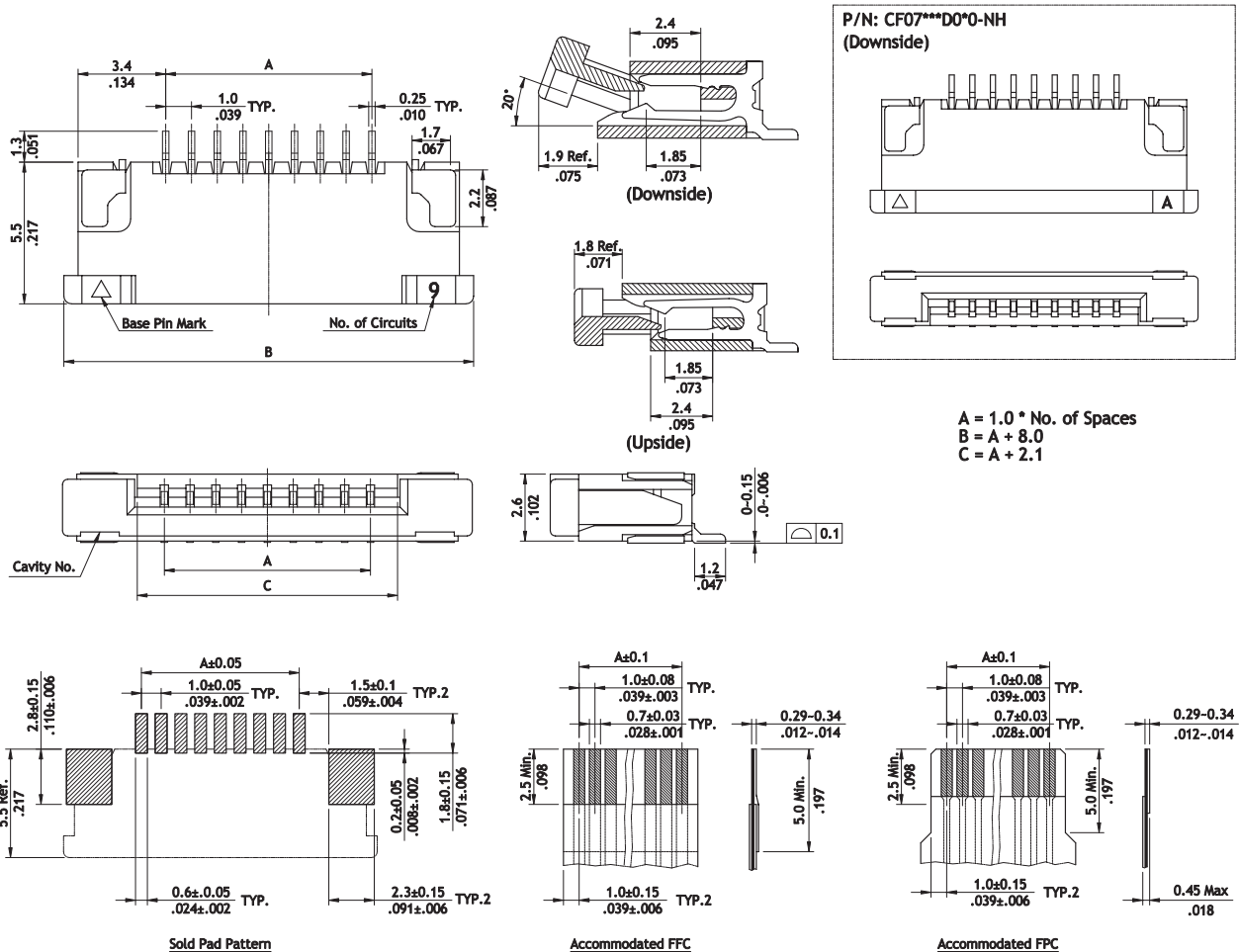
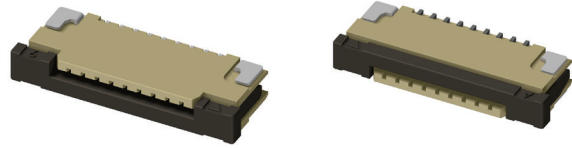

**Ordering Code**

① ② ③ ④ ⑤ ⑥ ⑦ ⑧  
**CF07 30 1 D 0 R 0 - NH**

- ① Series No.
- ② No. of Circuits: 04 ~ 32
- ③ Plating Code:  
 1 = Matte Tin over Nickel  
 2 = Gold flash over Nickel
- ④ Contact style :  
 D = Downside contact  
 U = Upside contact
- ⑤ Color : 0 = Nature
- ⑥ Packing : R = Tape & Reel
- ⑦ Options: 0 = Standard
- ⑧ NH = For Lead Free soldering process and Halogen-Free

**CF08 Series 1.00mm(.039")H=2.60/3.55 SMT LIF & SMT LIF Vertical FFC/FPC**

CF

- ⊙ Tin over copper alloy dual contacts
- ⊙ Insulator: High temperature plastic UL 94V-0
- ⊙ With metal fixed tabs to secure connector in place

RoHS Compliant

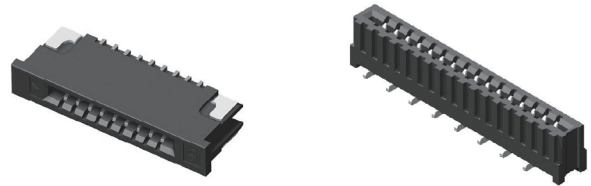

P/N CF08\*\*1H1\*0-NH

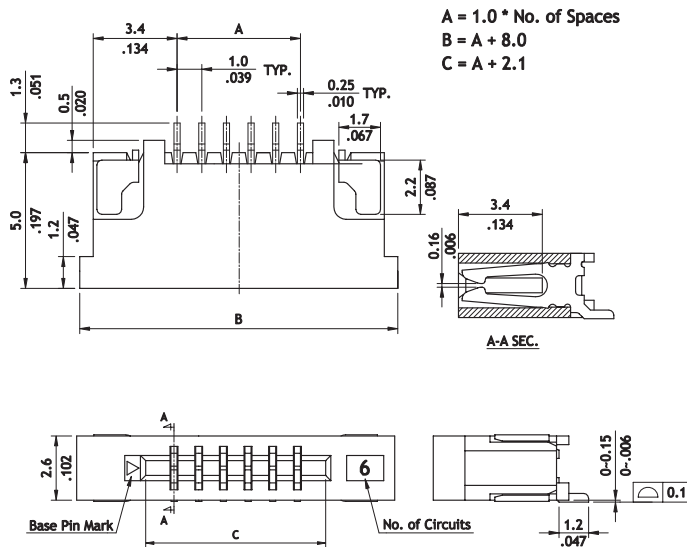

P/N CF08\*\*1M1\*0-NH

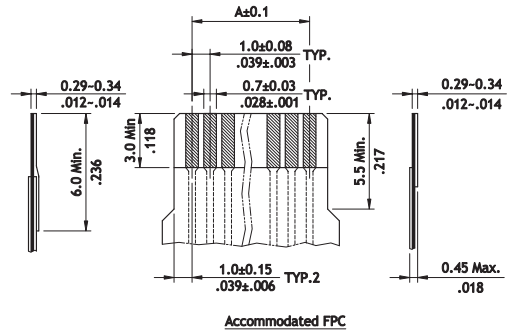
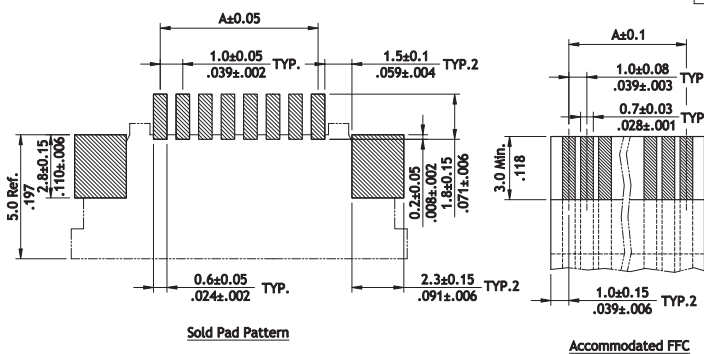
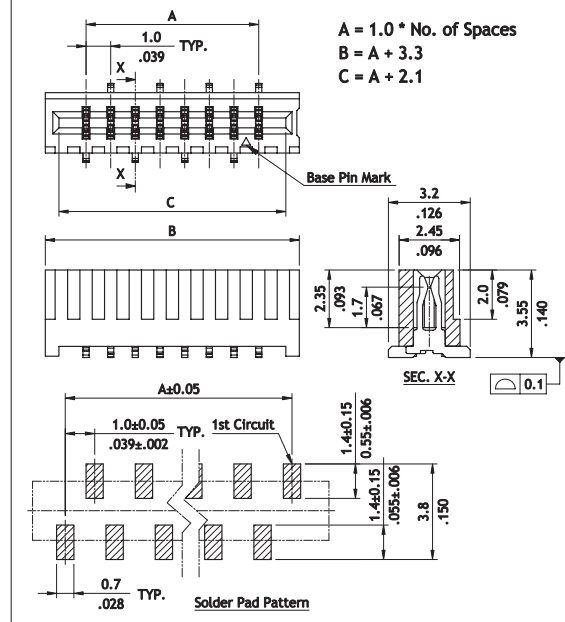

**Ordering Code**

① ② ③ ④ ⑤ ⑥ ⑦ ⑧  
**CF08 32 1 H 2 R 0 - NH**

① Series No.

② No. of Circuits: 04 ~ 32

③ Plating Code:

1 = Matte Tin over Nickel

④ Contact Style:

H = SMT Side Entry

M = SMT Top Entry

⑤ Color: 1 = Black (Top Entry)

2 = Brown (Side Entry)

⑥ Packing: R = Tape & Reel

T = Tube

⑦ Other Options: 0 = Standard

\*Special options consult manufacturer

⑧ NH = For Lead Free IR process and Halogen-Free

**CF09 Series 1.00mm(.039")H=2.60/5.50 DIP LIF FFC/FPC Connectors**

- ⊙ Tin over copper alloy dual contacts
- ⊙ Insulator: High temperature plastic UL 94V-0
- ⊙ Low Insertion Force

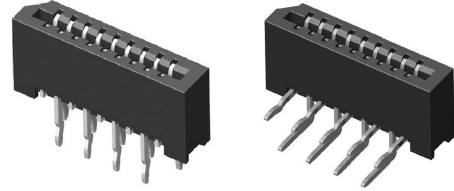

P/N CF09\*\*1V100-NH

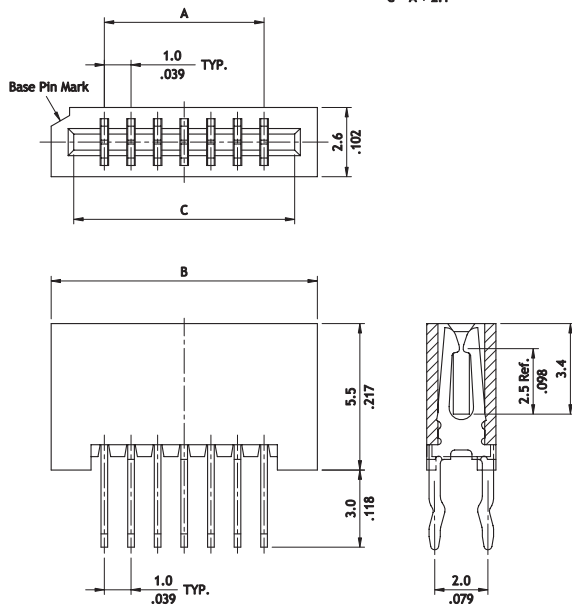

P/N CF09\*\*1H100-NH

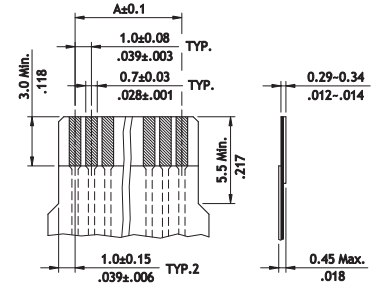
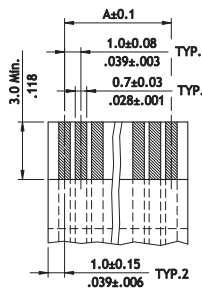
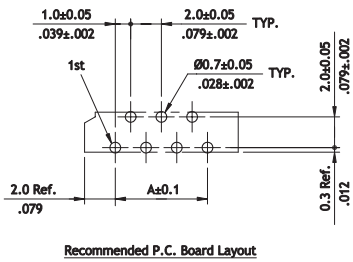
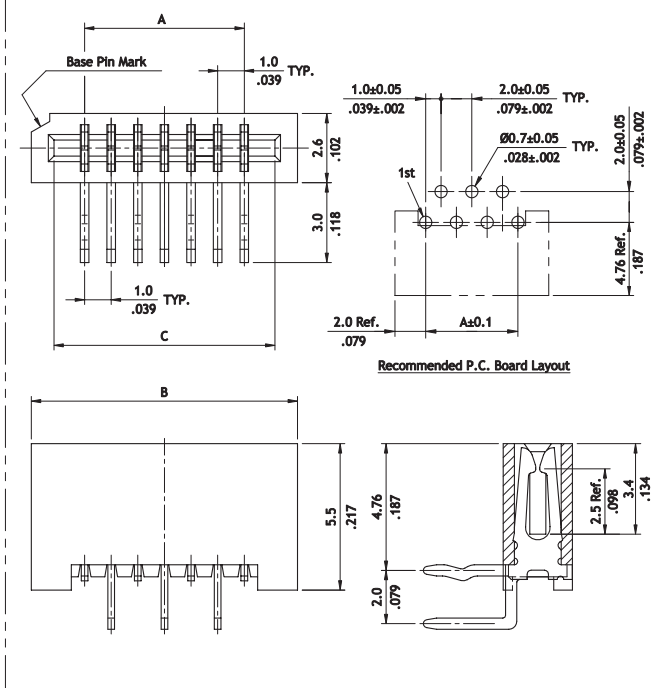

**Ordering Code**

① ② ③ ④ ⑤ ⑥ ⑦  
**CF09 32 1 H 1 00 - NH**

- ① Series No.
- ② No. of Circuits: 04~ 32
- ③ Plating Code:  
1 = Matte Tin over Nickel

- ④ Contact Style:  
V = Top Entry  
H = Side Entry
- ⑤ Color: 1 = Black

- ⑥ Other Options: 00 = Standard  
\*Special options consult manufacturer
- ⑦ NH = For Lead Free Soldering process and Halogen-Free

**CF73 Series 1.00mm(.039") H=3.30 SMT ZIF One-Touch FFC/FPC Connectors**

CF

- ⊙ FFC/FPC zero insertion force and high retention force
- ⊙ Insulator : High temperature plastic UL 94V-0, Color Black
- ⊙ Cover : High temperature plastic UL 94V-0, Color Nature
- ⊙ Actuator designed easy for FPC installation and reliable operation

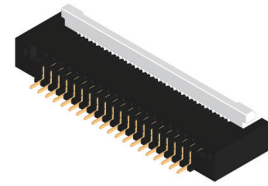

RoHS Compliant

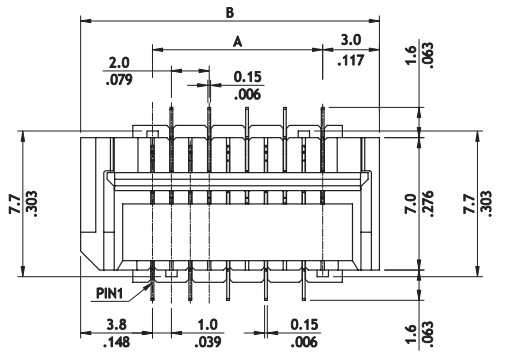

DIM.A = 1.0 x No. of Spaces

DIM.B = DIM.A + 6.8

DIM.C = DIM.A + 3.15

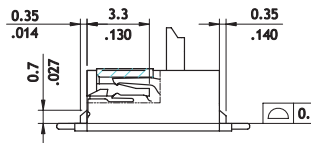

(Length to Contact Point)

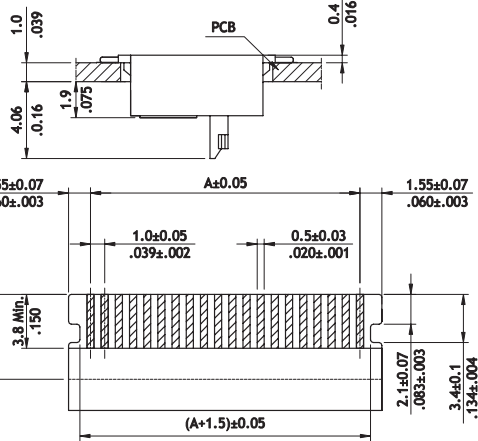
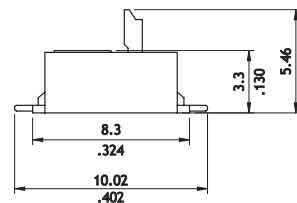
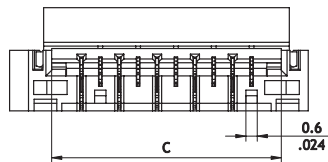

Accommodated FFC/FPC  
Thickness= 0.30±0.03mm

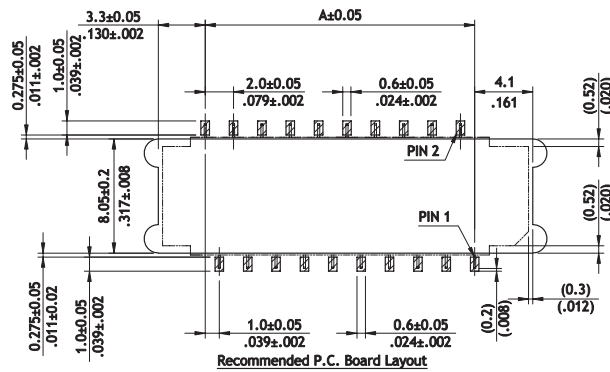

**Ordering Code**

① ② ③ ④ ⑤ ⑥ ⑦ ⑧  
**CF73 10 1 B 1 R0 - 10 - NH**

- ① Series No.
- ② No. of Circuits: 10
- ③ Plating Code:  
F= Gold flash over Nickel  
1= Matte Tin over Nickel
- ④ Type : B = Middle Mount Type
- ⑤ Color: 1 = Black
- ⑥ Packing: R0 = Reel packing
- ⑦ Pitch = 1.00 mm
- ⑧ NH = For Lead Free soldering process and Halogen-Free

CF10 Series 1.00mm(.039")H=3.80/5.00 DIP ZIF FFC/FPC Connectors

- ⊙ Tin contacts with kinked tail
- ⊙ Insulator: High temperature plastic UL 94V-0, Color Nature
- ⊙ Slider: High temperature plastic UL 94V-0, Color Brown / Black

RoHS Compliant 

P/N CF10\*\*1U0T0-NH

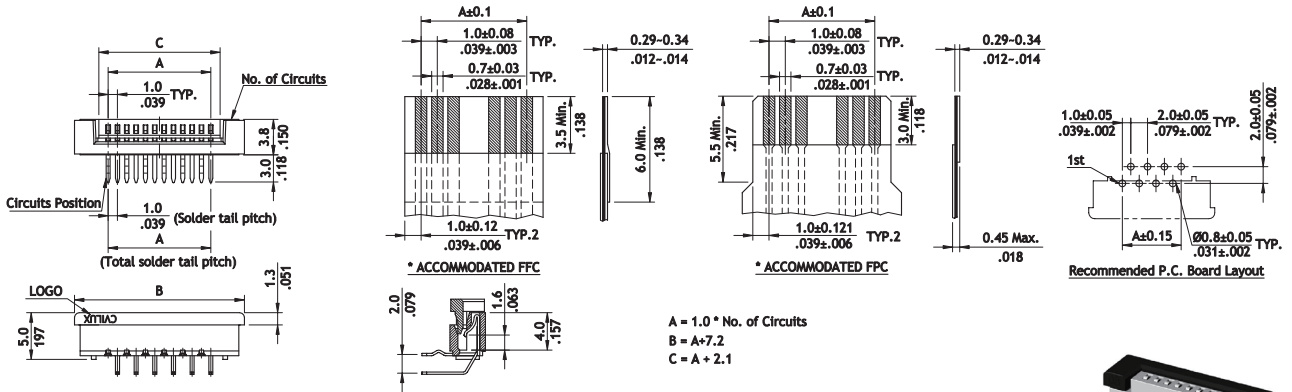

P/N CF10\*\*1D0T0-NH

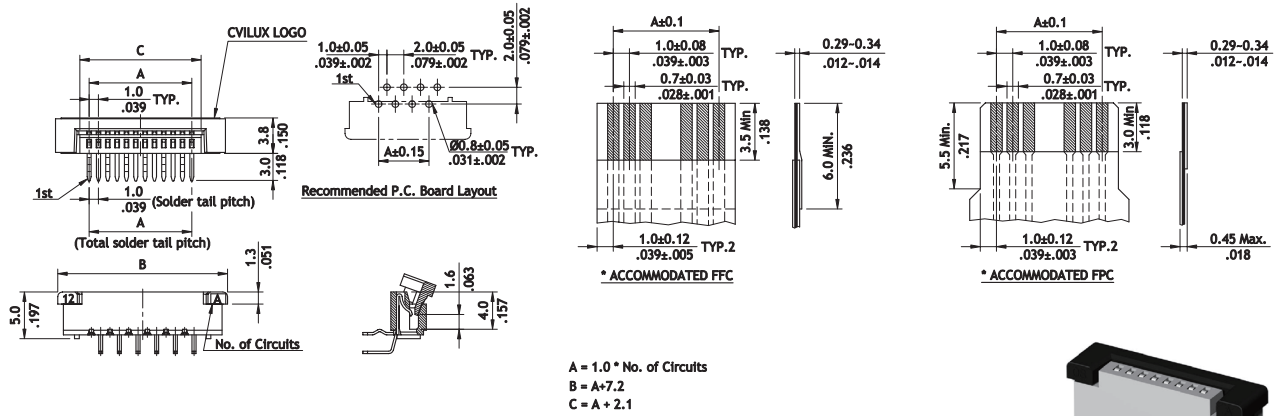

P/N CF10\*\*1V0T0-NH

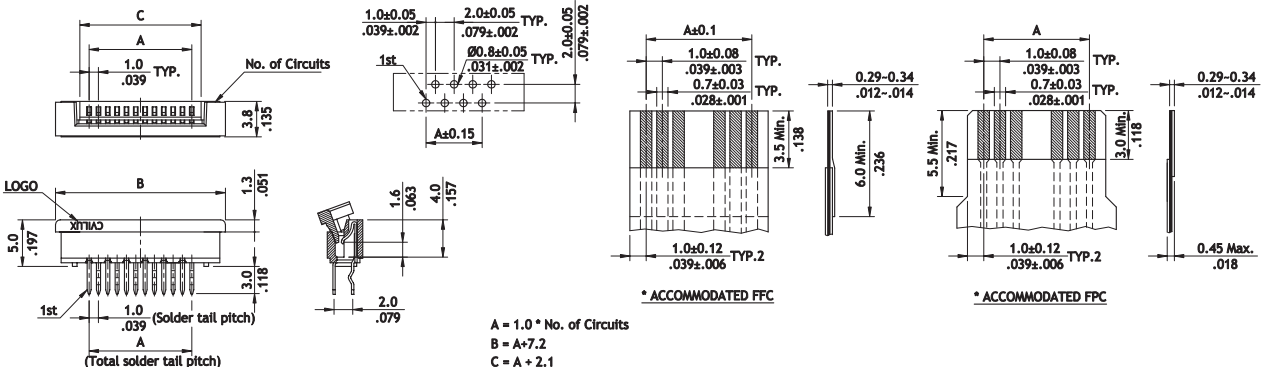

**CF10 Series 1.00mm(.039")H=5.20 SMT ZIF FFC/FPC Connectors**

CF

- ⊙ Insulator: High temperature plastic UL 94V-0, Color Nature
- ⊙ Slider: High temperature plastic UL 94V-0, Color Black

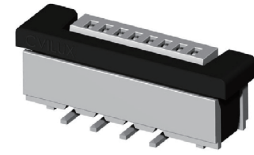

RoHS Compliant

P/N CF10\*\*1M0\*0-\*\*

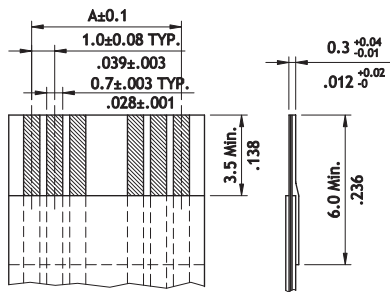
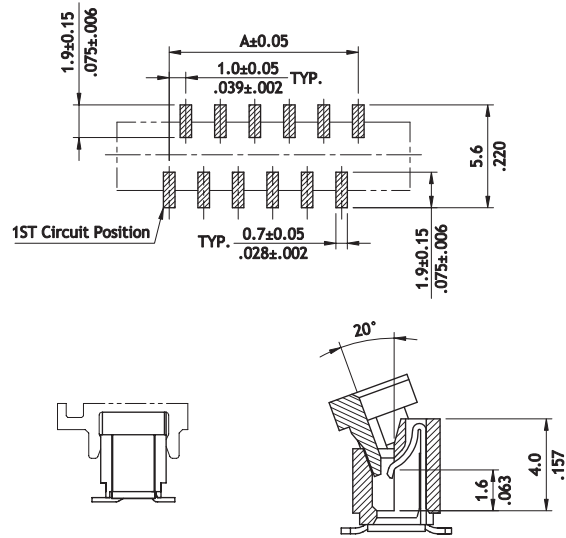
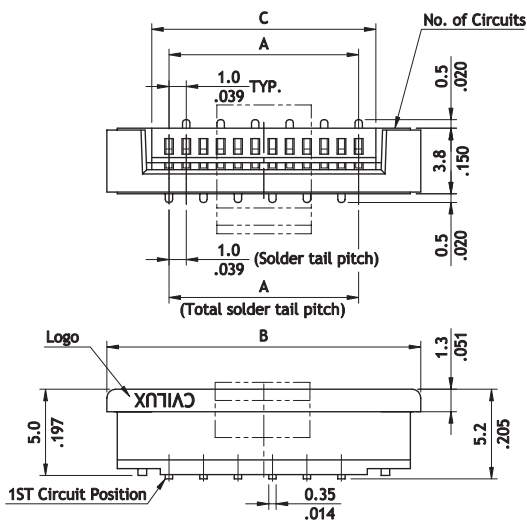

Accommodated FFC

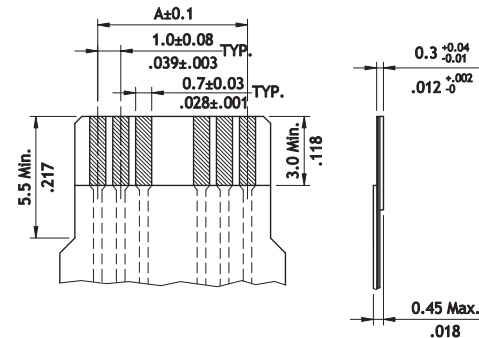

Accommodated FPC

**Ordering Code**

① ② ③ ④ ⑤ ⑥ ⑦ ⑧  
**CF10 32 1 V 0 T 0 - NH**

① Series No.

② No. of Circuits: 04 ~32

③ Plating Code:

1 = Matte Tin over Nickel

④ Contact Style:

U = Upside Contact (DIP)

D = Downside Contact (DIP)

V = Vertical Type (DIP)

M = Top entry Type (SMT)

⑤ Color: 0 = Nature

⑥ Packing: R = Tape & Reel

T = Tube

⑦ Other Options: 0 = Standard

\*Special options consult manufacturer

⑧ NH = For Lead Free IR process and Halogen-Free

CF16 Series 1.00mm(.039")H=3.80/5.00 DIP LIF FFC/FPC Connectors

- ⊙ Tinned contacts with kinked tail
- ⊙ Insulator: High temperature plastic UL 94V-0

RoHS Compliant

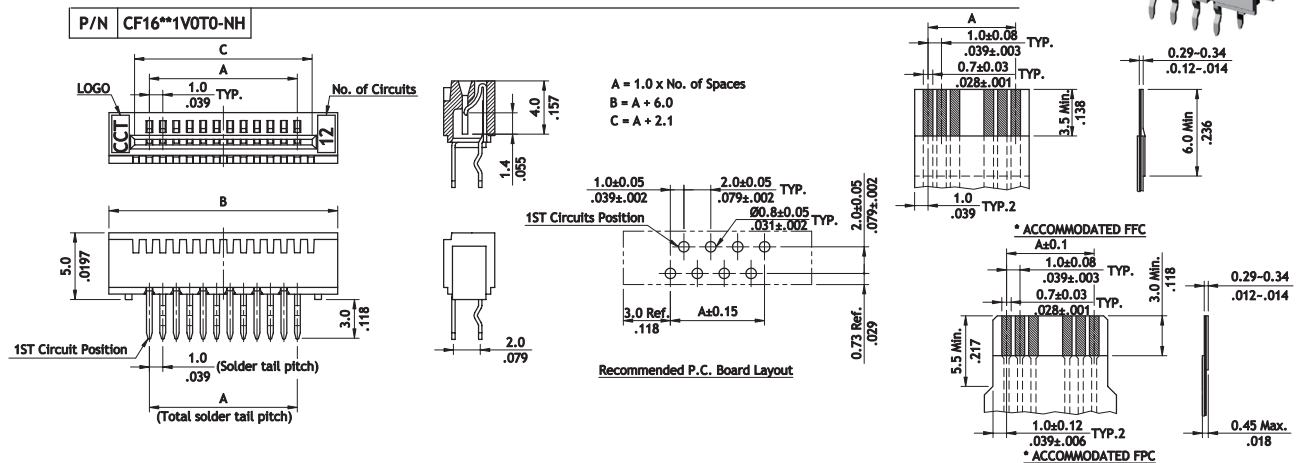
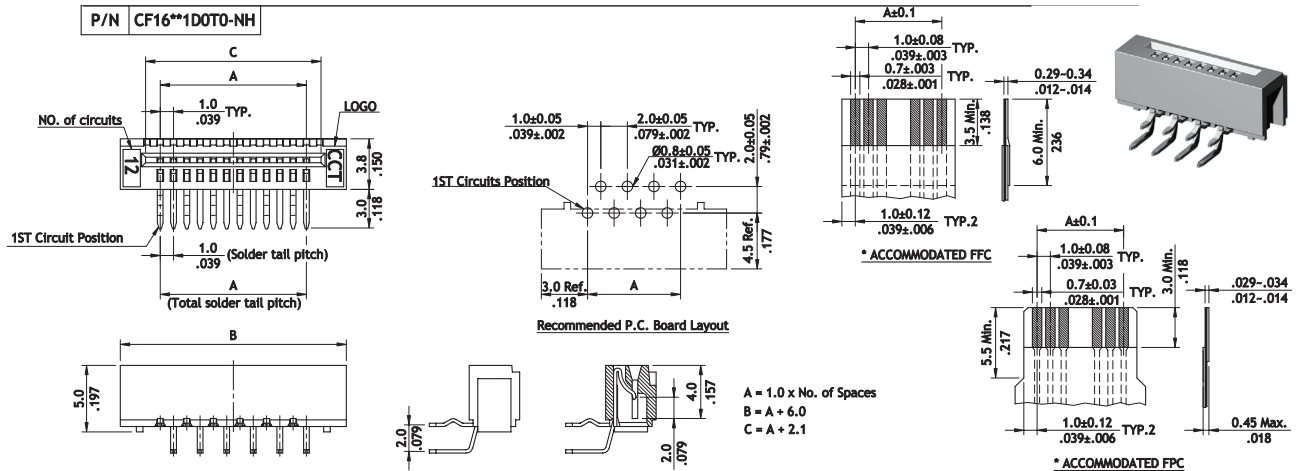
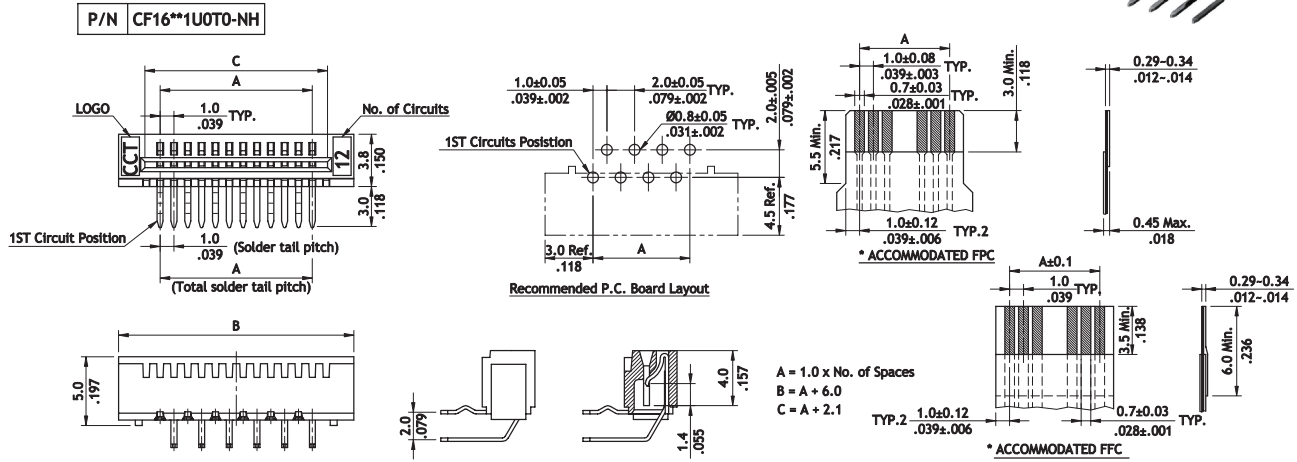
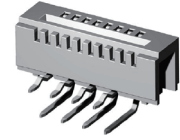

**CF16 Series 1.00mm(.039")H=3.80/5.20 SMT LIF FFC/FPC Connectors**

CF

- ⊙ Insulator: High temperature plastic UL 94V-0, Color Nature
- ⊙ With metal fixed tabs to secure connector in place

RoHS Compliant

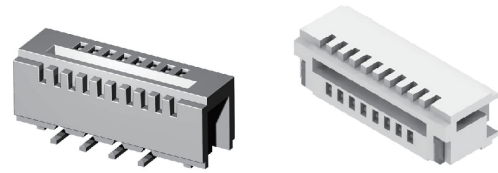

P/N CF16\*\*1M0\*0-NH

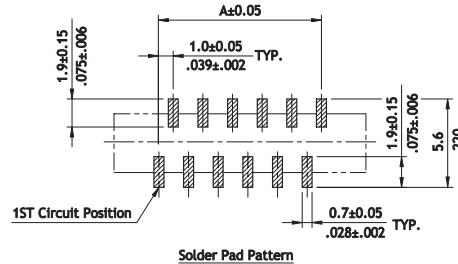
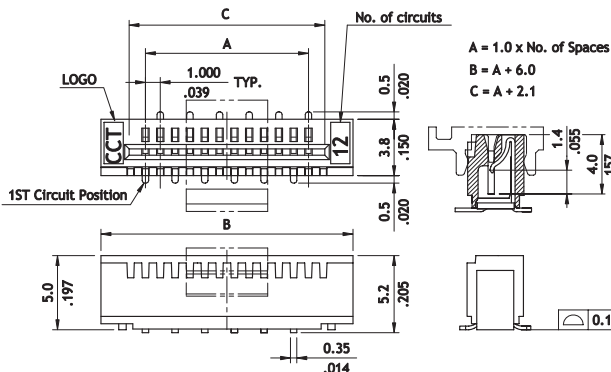

P/N CF16\*\*1S0\*0-NH

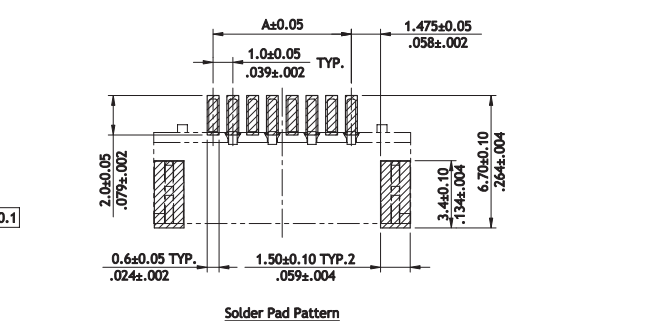
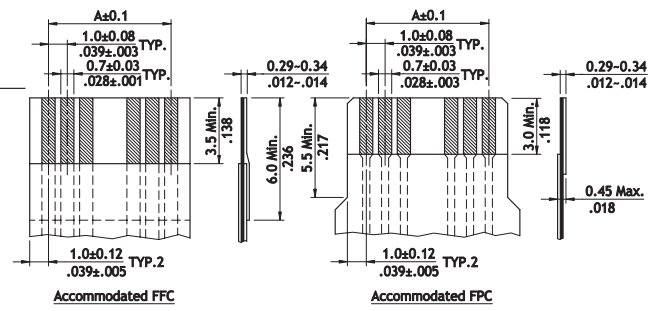
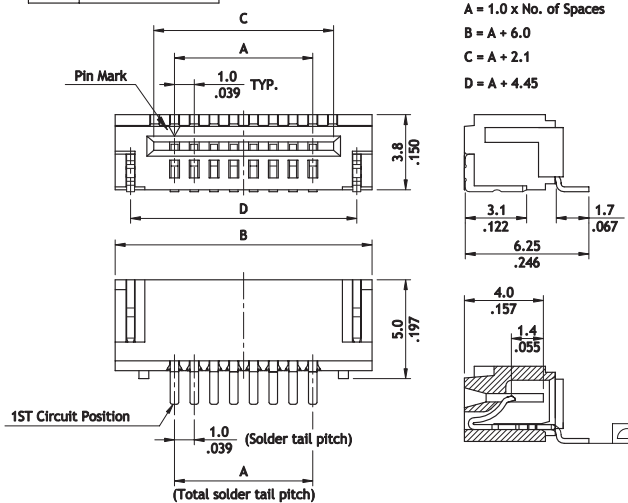

Ordering Code	①	②	③	④	⑤	⑥	⑦	⑧
	CF	16	32	1	V	0	T	0 - NH

① Series No.  
 ② No. of Circuits: 03 ~ 32  
 ③ Plating Code:  
 1 = Matte Tin over Nickel  
 ④ Contact Style: U= Upside Contact (DIP)  
 D= Downside Contact (DIP)  
 V= Vertical Type (DIP)  
 M= Top entry Type (SMT)  
 S= Side entry Type (SMT)  
 ⑤ Color: 0 = Nature  
 ⑥ Packing: T = Tube packing without Pad (DIP or SMT)  
 R = Reel packing (SMT)  
 ⑦ Other Options: 0 = Standard  
 \*Special options consult manufacturer  
 ⑧ NH = For Lead Free soldering process and Halogen-Free

CF12 Series 1.25mm(.049")H=4.00/6.80 DIP LIF FFC/FPC Connectors

- ☉ Tin plated contacts with kinked tail
- ☉ Insulator: High temperature plastic UL 94V-0, Color Black

RoHS Compliant

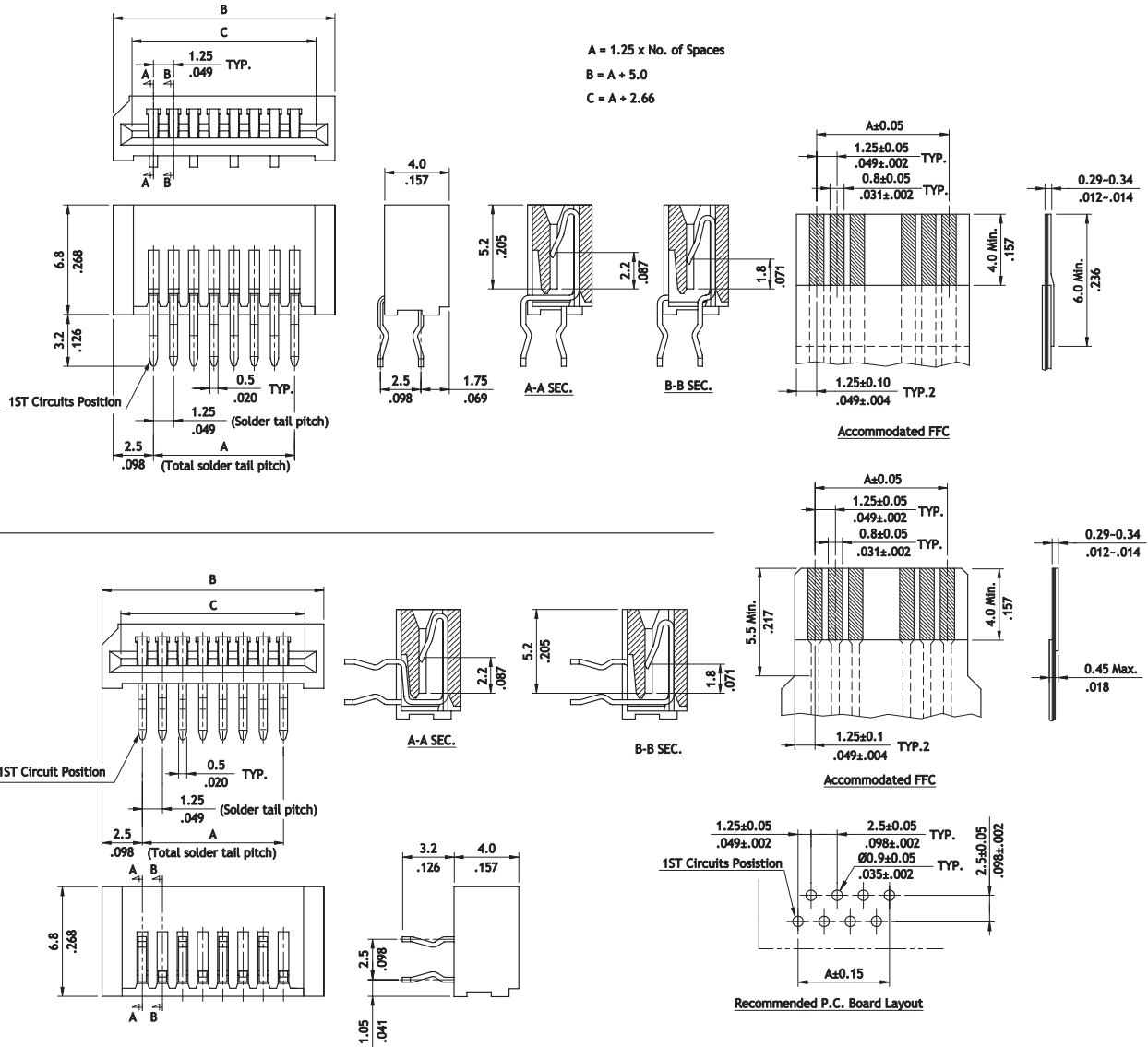
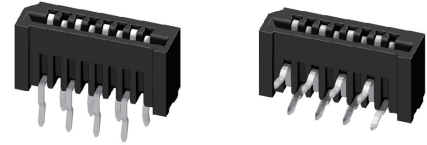

Ordering Code

① ② ③ ④ ⑤ ⑥ ⑦  
**CF12 36 1 V0 T 0 - NH**

- ① Series No.
- ② No. of Circuits: 03 ~ 36
- ③ Plating Code:  
1 = Matte Tin over Nickel
- ④ Entry Options:  
V0 = Straight  
H0 = Right Angle
- ⑤ Packing: T=Tube
- ⑥ Other Options: 0 = Standard  
\*Special options consult manufacturer
- ⑦ NH = For Lead Free soldering process and Halogen-Free

## Introduction

To meet the demands of miniaturizing electronic products, to solve critical size requirement problem, CviLux now provides you low cost multiple pitches flat flexible cables in 0.5mm, 1.0mm, 1.25mm, and 2.54mm pitch per your requirements.

The insulation of Flat Flexible Cables is made of PET, there are options with variety of terminal types in both cable ends per your requirements. They are small, light weight, thin, flexible and easy to connect with CviLux CF series FFC connectors.

Our Flat Flexible Cable can be used several laminated copper wire, please refer to our product specification for detailed information. Customized FFC available, please consult sales person.

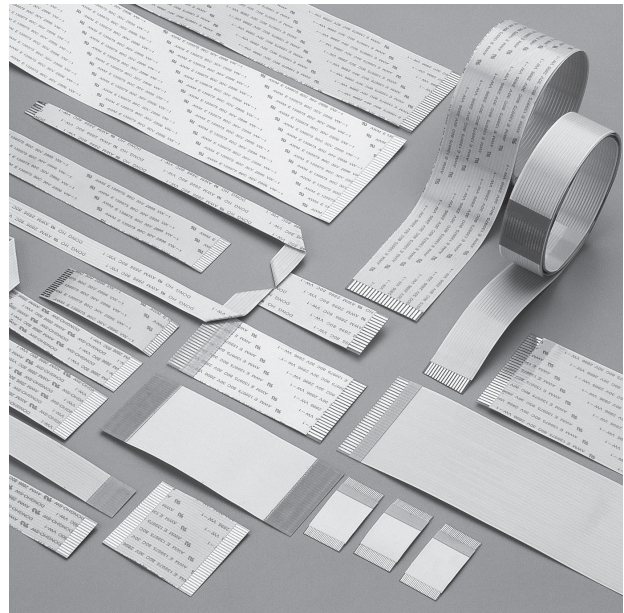

FFC

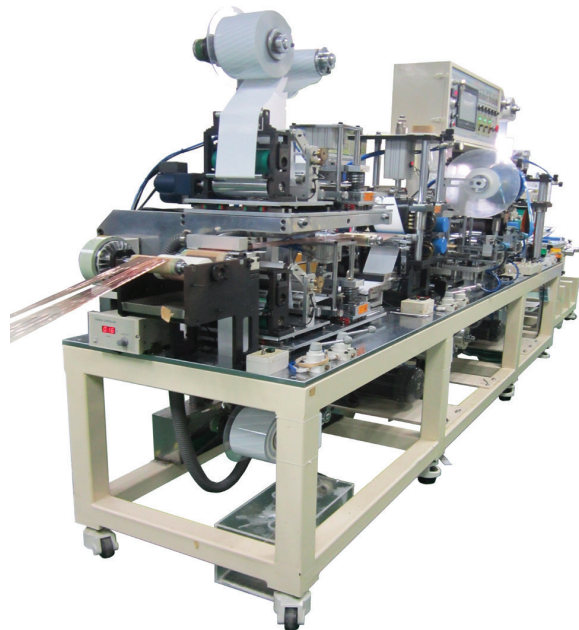
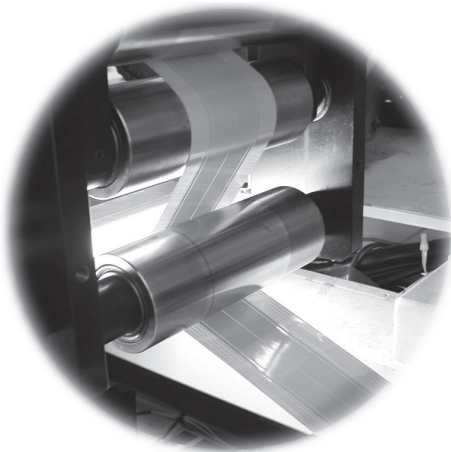
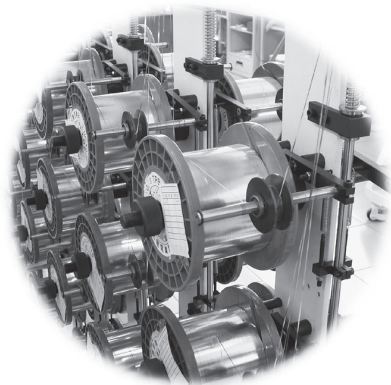
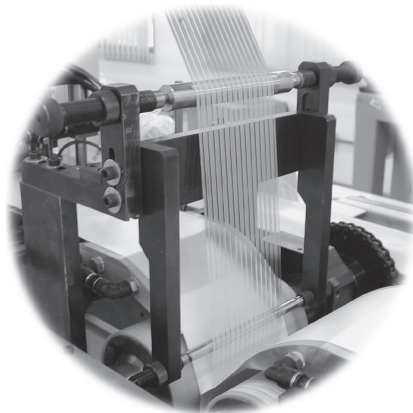

FLAT FLEXIBLE CABLE

**Features/Advantages/Materials/Rating**

RoHS Compliant 

**Features & Advantages**

- ⊙ Light weight and flexible
- ⊙ Compactness of electronic products
- ⊙ Easy assembling and low production cost
- ⊙ Simple and clean internal design

**Materials**

- ⊙ Conductor : See ordering code
- ⊙ Insulation : Polyester (PET)
- ⊙ Adhesive layer : Flame retardant Polyvinyl chloride (PVC) or Polyester adhesive layer
- ⊙ Color : White or Black
- ⊙ Support Tape : Polyester (PET)
- ⊙ Adhesive layer : Polyester adhesive layer
- ⊙ Color : Blue

**Rating**

⊙ UL File No. : E208903

UL Style	Temp.	Volt.
2896	80°C	30V
20624	80°C	60V
20696	80°C	30V
20706	105°C	60V
20798	80°C	60V
20861	105°C	60V
20941	105°C	90V
20960	105°C	300V

\*Standard Products: UL20706

\*Other UL type required, please consult sale person.

**Applications**

- ⊙ Audio, Video, Scanner, Cordless Phone, Fax, Notebook, P.C., Monitor, Pad, Car audio, TV, Security equipment, Micro-motors, Home Appliance...etc.
- ⊙ Shield Type : EMI Application



Notebook P.C



PAD



Smart Phone



Digital Camera



Mobile



MFP



Monitor



TV

**Connectors**

⊙ PLUG IN

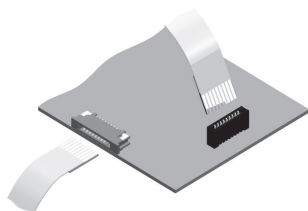

⊙ SOLDERING

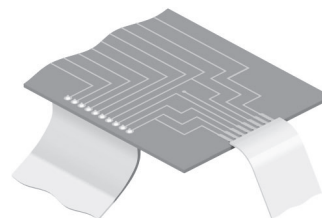

**Ordering Code**

1 **F F C**
2 **C**
3 **1 2**
4 **0 4**
5 **T**
6 **1**
7 **0 6 0**
8 **0**
9 **0**
10 **- 3**
11 **0 0**

FFC

**1** Series No.

**2** Conductor Pitch:

Code	Pitch(mm)
A	2.54
B	1.25
C	1.00
E	0.50

**3** Number of Conductors

**4** Material : Copper Conductor Size

Code	Size		Applying Pitch(mm)
	Thickness	Width	
01	0.10	1.27	2.54
02	0.10	0.80	1.25
03	0.05	0.80	
10	0.035	0.80	
04	0.10	0.70	1.00
05	0.05	0.70	
06	0.035	0.70	
14	0.05	0.65	
15	0.10	0.65	0.50
08	0.05	0.30	
09	0.035	0.30	

**5** Plating code: T= Sn, Y=Gold flsch over Nickel

B=Gold plated 3µ" over bare copper

**6** Terminal Types: See below Terminal Types table

Sn plated conductor use T1, T2,

T7, T9. Gold conductor use G1/B1 and G2/B2

**7** Overall Length

**8** Strip Length: 0 = Standard

**a** When the conductor pitch is 0.5mm;

Standard strip length = 4.0mm

**b** When the conductor pitch is 1.0, 1.25 and 2.54mm;

Standard strip length = 5.0mm

**c** Other length options available

**9** Support Tape Length: 0 = Standard

**a** When the conductor pitch is 0.5mm;

Standard length = 8.0mm

**b** When the conductor pitch is 1.0, 1.25 and 2.54mm;

Standard length = 10.0mm

**c** Other length options available

**d** Max. Support Tape length: 20.0mm

**10** UL Style No.

-N = Non printing(Standard)





-3 = UL 20706(Standard) H=UL 20706(Halogen Free)

**11** Other Option:

00 = Standard

**Terminal Type Table**

**Sn Plated:**

Code	Type	Code	Type
T1		T7	
T2		T9	

**Gold Plated:**

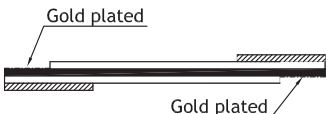
Code	Type	Code	Type
Y1/B1		Y2/B2	

Shape, Construction and Dimensions

Unit:mm

No.	ITEM	Abbr.	FORMULATION	TOLERANCE			
				P=0.50	P=1.00	P=1.25	P=2.54
1.	Pitch	P	Typical	±0.05	±0.08	±0.10	±0.15
2.	Total pitch	Pt	$Pt=(n-1) \times P$	±0.08	±0.10	±0.15	±0.20
3.	Width	W	$W=(n+1) \times P$	±0.08	±0.10	±0.20	±0.20
4.	Margin	M	$M=(W-Pt)/2$	±0.08	±0.12	±0.15	±0.20
5.	Insulation length	$\ell$	$\ell = L - (S_1 + S_2)$	(30-100)±3, (101-300)±5, (301-600)±10, (Length more than 601mm)±15mm			
6.	Total (Cable) length	L	$L = \ell + (S_1 + S_2)$				
7.	Strip length	S	When the terminal type is T1, T2 ; $S_1 = S_2$	4±1	5±1		
8.	Support tape length	d	$d = S \times 2$	8±2	10±2		
9.	Conductor width	Cw	Various	0.3±0.02	0.7±0.03	0.8±0.03	1.27±0.04
10.	Conductor thickness	Ct	Various	N/A	0.10±0.01		
				0.05±0.01			
				0.035±0.01			
11.	Terminal thickness	t	Typical	0.29~0.34			

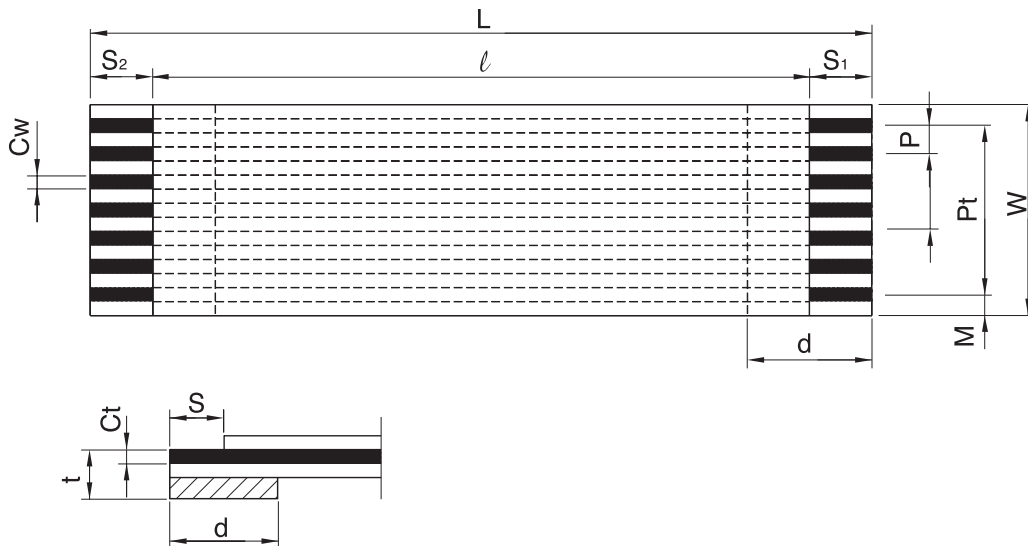

## Feature & Caution

This product is economic interconnect configurations including jumpers, formed, shielded, terminated and assembled cables, characterized by its excellent flexibility, space saving, light weight and easy assembly. It can be easily inserted or pulled out from the connector or directly soldered onto the PCB. We offer flexibility in design, where the number of conductors, pitch and length can be freely selected to meet any assembly requirements. This design partnership enables our customers to produce quality products at competitive costs.

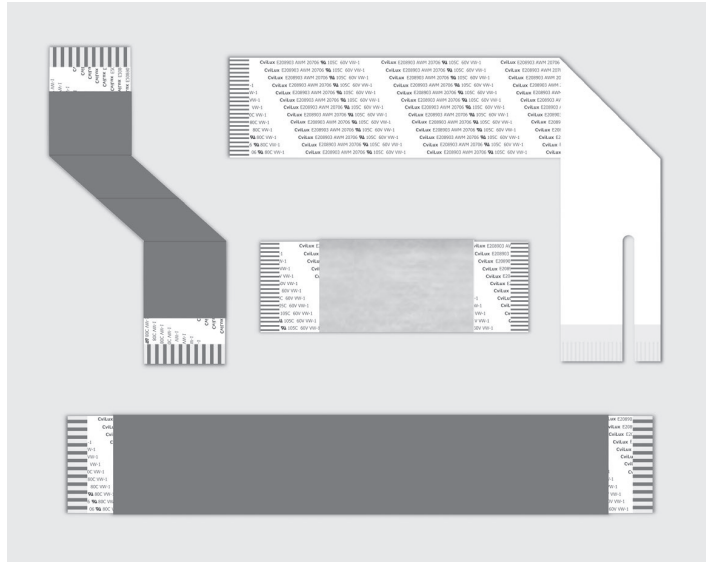

FFC

## CAUTION

- ⦿ Please aware minimum order US\$1300 per item in requiring for FFC
- ⦿ Please fill up below form for standard configuration and indicate the quantities you will need for your order.
- ⦿ Formed, shielded, terminated and assembled cables, please submit drawing or sketch for quotation.

## TYPE -

⦿ Please make a copy, fill up this form and send by fax or e-mail to us for sample request

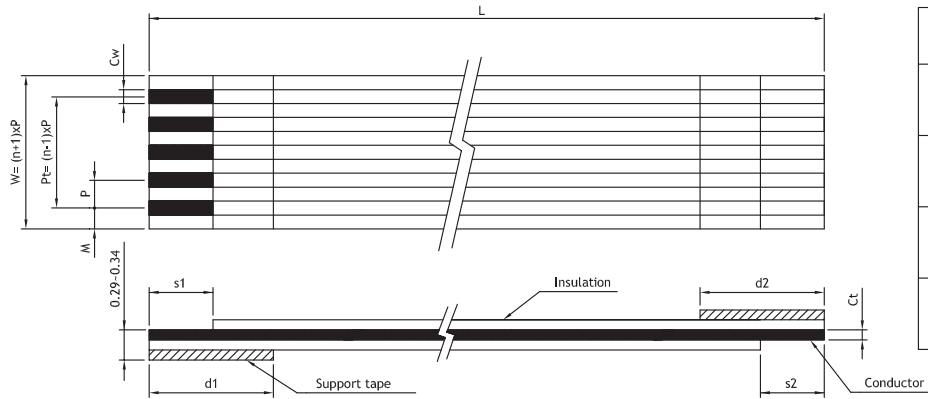

TERMINAL TYPE	
T1	
T2	
T7	
T9	

UL Style		Terminal Type		Dimension										Support Tape Color
No.	No. of Conductor	P	Pt	L	W	M	Cw	Ct	S1	S2	d1	d2		

FLAT FLEXIBLE CABLE

**Performance**
**Electrical Performance**

ITEM	TEST CONDITION	REQUIREMENT				
		Conductor size	Resistance	Remarks		
1.1	Conductor resistance	JIS C-3102 (at 20°C)	Ct	Cw	Tinned copper	
						0.1
			0.80	less than 0.26 Ω/m		
			0.70	less than 0.30 Ω/m		
			0.65	less than 0.30 Ω/m		
			0.05	0.80		less than 0.52 Ω/m
				0.70		less than 0.65 Ω/m
				0.65		less than 0.57 Ω/m
				0.30		less than 1.40 Ω/m
			0.035	0.80		less than 0.82 Ω/m
				0.70		less than 1.09 Ω/m
				0.30		less than 2.20 Ω/m
1.2	Dielectric strength	AC 500V 1 min	No breakdown			
1.3	Insulation resistance	DC 500V	More than 1000MΩ/m			

**Mechanical Performance**

ITEM	TEST CONDITION	REQUIREMENT
2.1	Elongation of insulator	JIS K-6732
2.2	Tensile strength of insulation	JIS K-6732
2.3	Abrasion test	φ 0.5mm, 600g, 60 cycles/min.
2.4	Pull-out test	–

**Environmental Performance**

ITEM	TEST CONDITION	REQUIREMENT
3.1	Operation temperature	–
3.2	Heat resistance	110°C x 96 Hrs
3.3	Heat cycle test	-40°C → +25°C → +85°C → +25°C x 5 cycle
3.4	Moisture resistance	40°C, 95% RH x 96Hrs
3.5	Flame test	UL Sub.758
3.6	Flexing test	180° folding test

**Flat Flexible Cable Assemblies - LVDS FFC Cable**

© LVDS interface for monitor & LCD TV application

RoHS Compliant

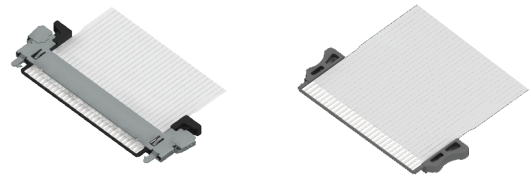

FFC

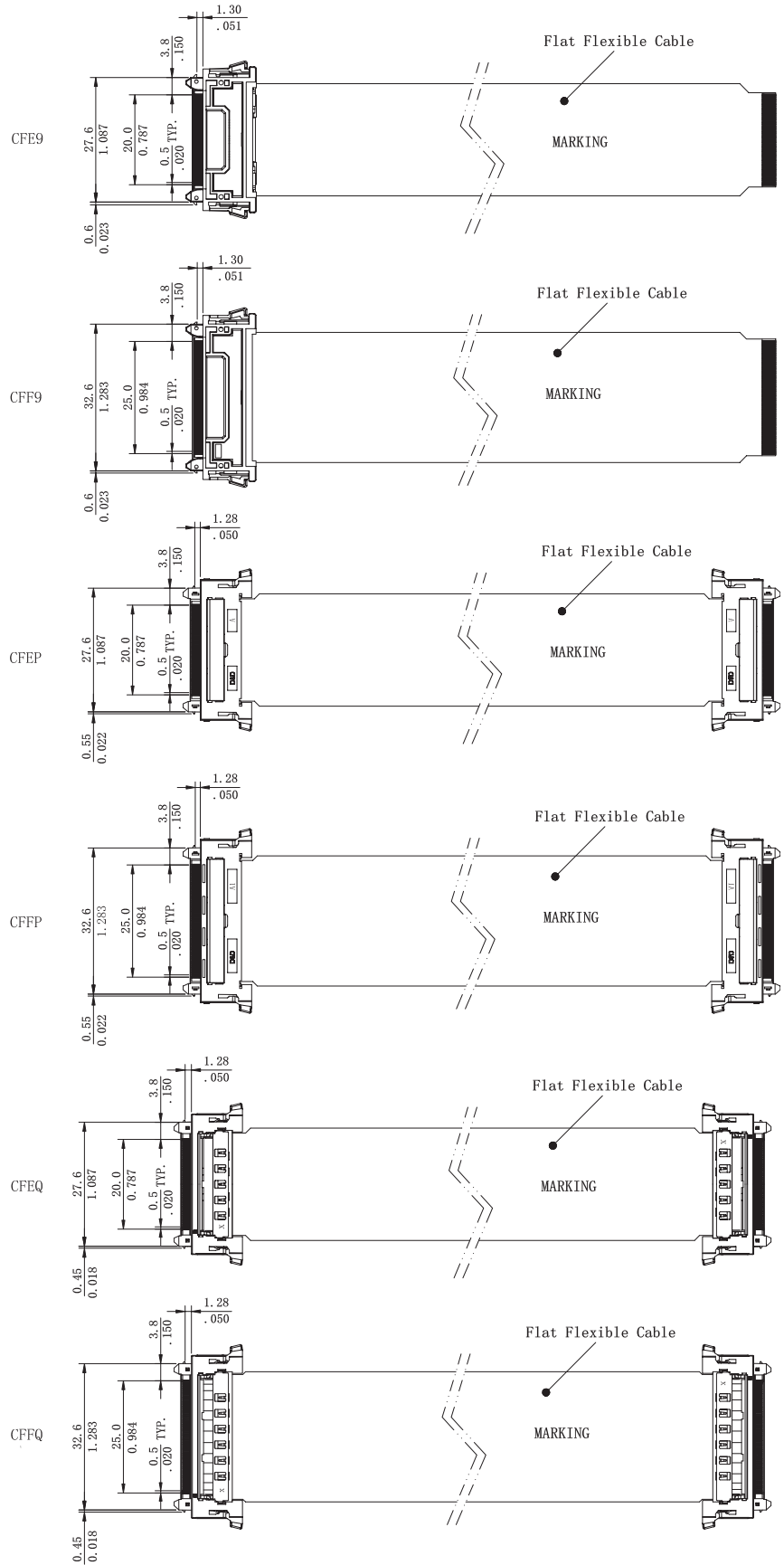

FLAT FLEXIBLE CABLE

**FFCA Series 2.54mm(.100") Flat Flexible Cable Assemblies**

- ⊙ Designed for flat flexible cable assembly
- ⊙ Available receptacle and board in pierce contact
- ⊙ Can be mated standard 2.54mm(.100") Pin header
- ⊙ Stackable end to end / side by side
- ⊙ Piercing termination provide reliable connection
- ⊙ Low cost and high reliability

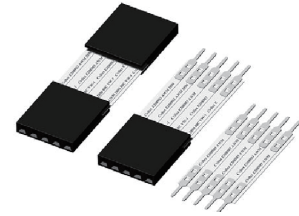

RoHS Compliant

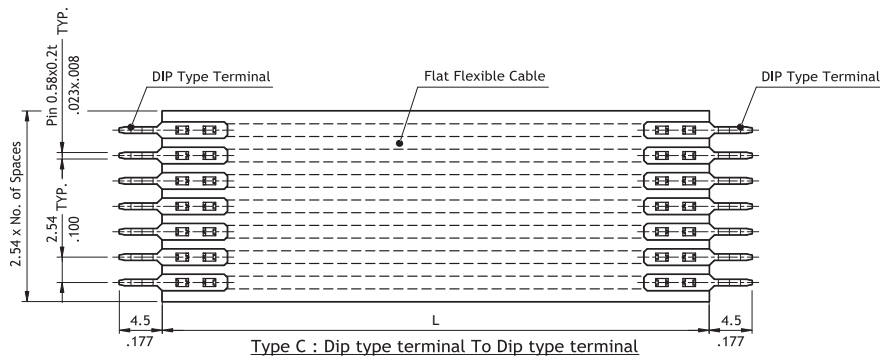
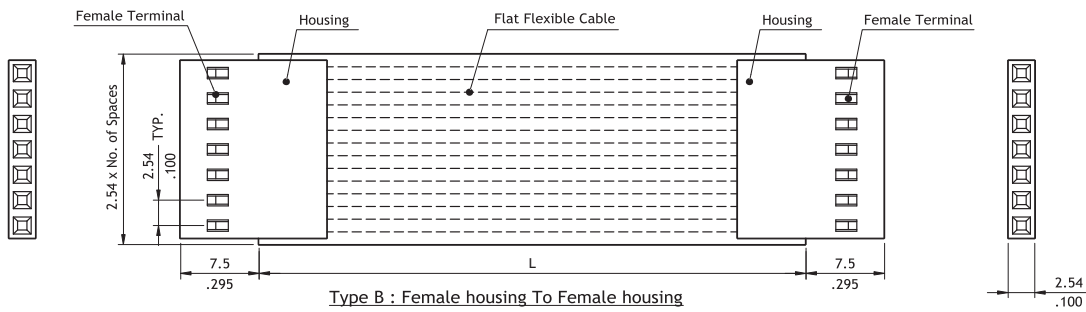
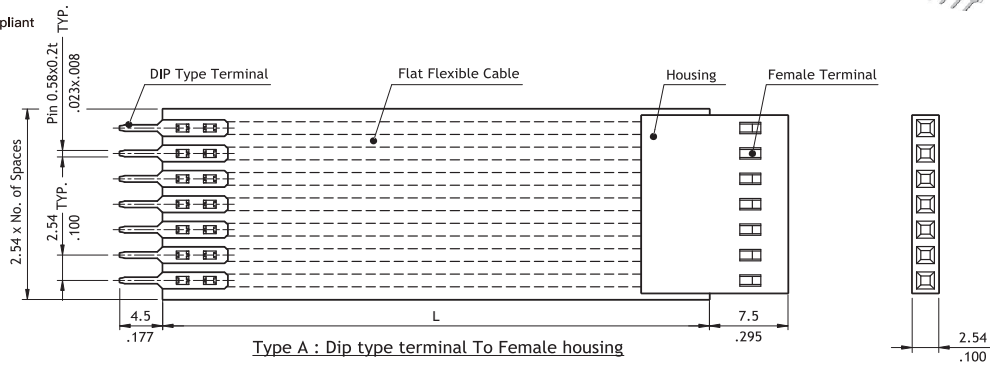

**Ordering Code**

① ② ③ ④ ⑤ ⑥ ⑦  
**FFC AS A 07 01 063 00**

- ① Series No.
- ② AS = Assembly
- ③ Type:  
 A = DIP type terminal to Female housing  
 B = Female housing to Female housing  
 C = DIP type terminal to DIP type terminal
- ④ No. of Circuits: 02 to 13 for A and B Type

- ⑤ FFC Conductor Size(Thicknessx Width):  
 01 = 0.1x1.27mm
- ⑥ FFC overall length:  
 063 = 63mm (Custom length option)
- ⑦ Other Option: 00 = Standard  
 \*Special option consult manufacturer  
 \*Minimum Order Quantity:5000pcs / order

**CVS1 Series 0.50mm(.020") H=3.70 LVDS Socket for TV**

- ⊙ Connector Height: 3.7mm
- ⊙ Better PCB holding strength of a board side connector with hold-downs to be soldered
- ⊙ VESA standard connector for LCD interface of LCD television
- ⊙ Insulation: High temperature plastic UL 94V-0, Color Black
- ⊙ Contact: Copper Alloy
- ⊙ Shell: Stainless Steel

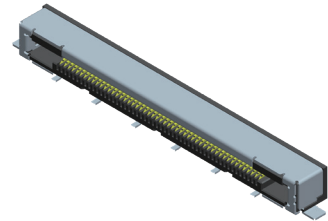

RoHS Compliant

CVS

P/N CVS141\*M1R0-NH

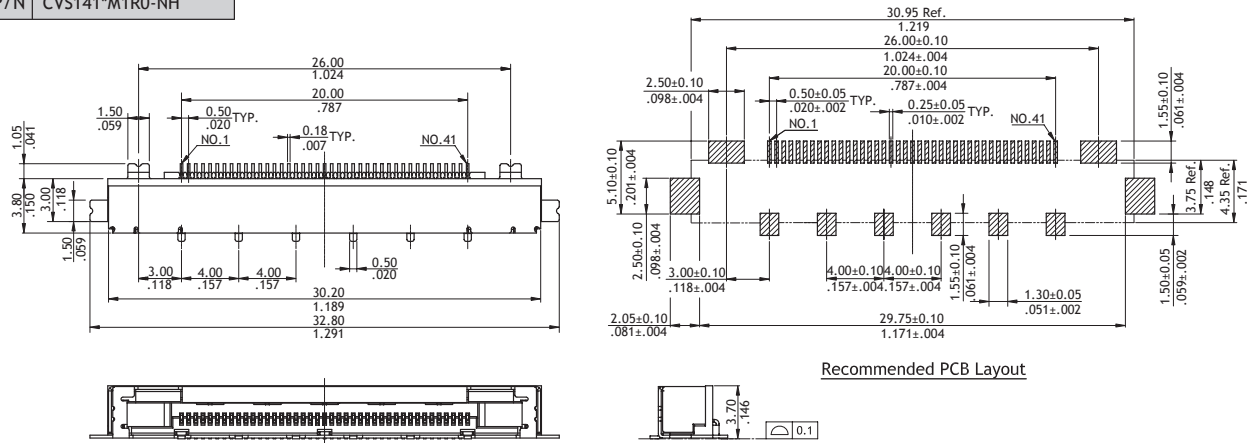

P/N CVS151\*M1R0-NH

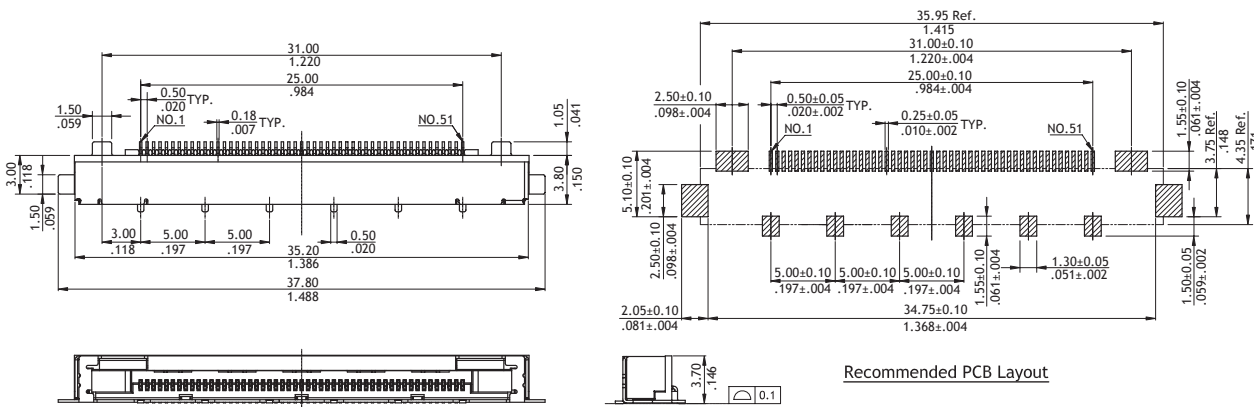

**Ordering Code**

① ② ③ ④ ⑤ ⑥ ⑦ ⑧  
**CVS1 51 D M 1 R 0 - NH**

- ① Series No.
- ② No. of Circuits: 41,51
- ③ Plating Code:  
 D = Selective 10μ" Gold flash over Nickel  
 \*Optional plating available but MOQ requested
- ④ M = SMT Type Header
- ⑤ Color: 1 = Black
- ⑥ Packing : R = Tape & Reel  
 T = Tube
- ⑦ Other Options:  
 0 = Standard  
 \*Special options consult manufacturer
- ⑧ NH = For Lead Free IR process and Halogen-Free

LVDS CONNECTOR

**CVS3 Series 0.50mm(.020") M/H=2.00 LVDS Socket for NB**

- ⊙ Mating Height 2.0mm
- ⊙ Product application: Laptop PC, NB
- ⊙ Insulation: High temperature plastic UL 94V-0, Color Black
- ⊙ Cap: High temperature plastic, Color Black
- ⊙ Shell: Copper Alloy
- ⊙ Contact: Copper Alloy

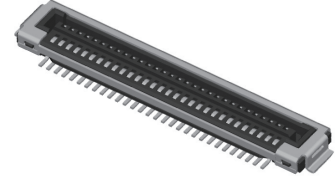

**RoHS** Compliant

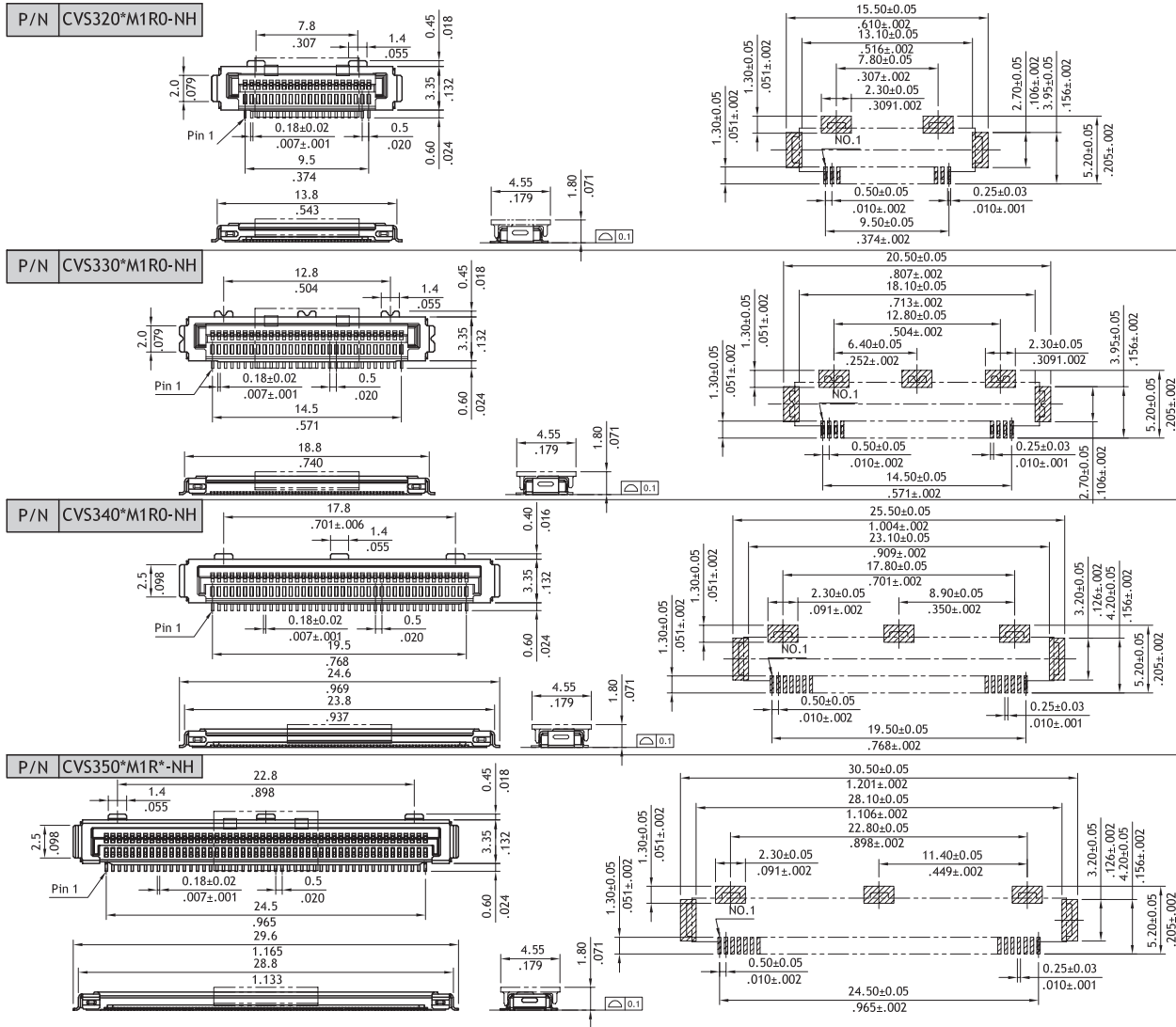

**Ordering Code**

① ② ③ ④ ⑤ ⑥ ⑦ ⑧  
**CVS3 50 2 M 1 R 0 - NH**

- ① Series No.
- ② No. of Circuits: 20, 30, 40, 50
- ③ Plating Code:  
2 = Gold flash over Nickel  
\*Optional plating available but MOQ requested
- ④ M = SMT Type Header
- ⑤ Color : 1 = Black
- ⑥ Packing : R = Tape & Reel
- ⑦ Other Options : 0 = Standard  
\*Special options consult manufacturer
- ⑧ NH = For Lead Free IR process and Halogen-Free

CVS

LVDS CONNECTOR

**CVS5 Series 0.50mm(.020") M/H=4.00 LVDS Socket for NB**

- ⊙ Mating Height: 4.0mm
- ⊙ Product application: NB, LCD
- ⊙ Insulation: High temperature plastic+Glass Fiber Filled Polyester,
- ⊙ UL 94V-0, Color Black
- ⊙ Cap: High temperature plastic, Color Black
- ⊙ Shell: Stainless Steel
- ⊙ Contact: Copper Alloy



RoHS Compliant

P/N CVS520\*M1R0-NH

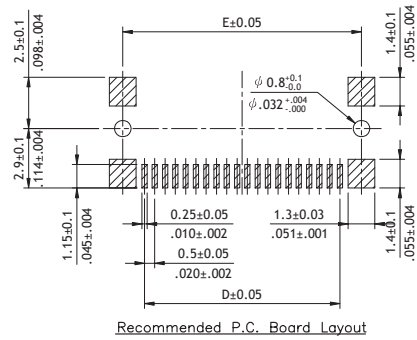
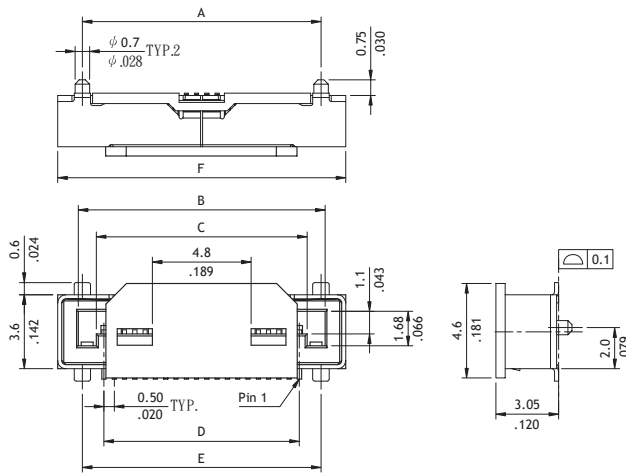

Circuits	Dimension					
	A	B	C	D	E	F
20	11.60(.457)	12.00(.472)	10.24(.403)	9.50(.374)	11.60(.457)	14.0(.551)

P/N CVS5\*\*\*M1RA-NH

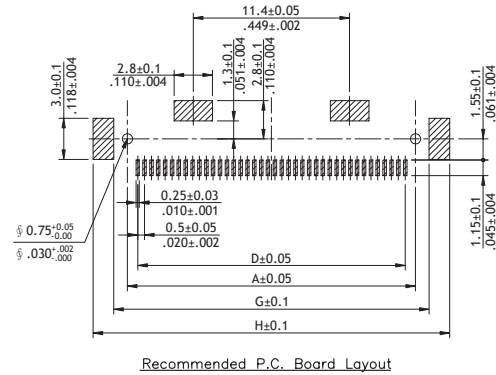
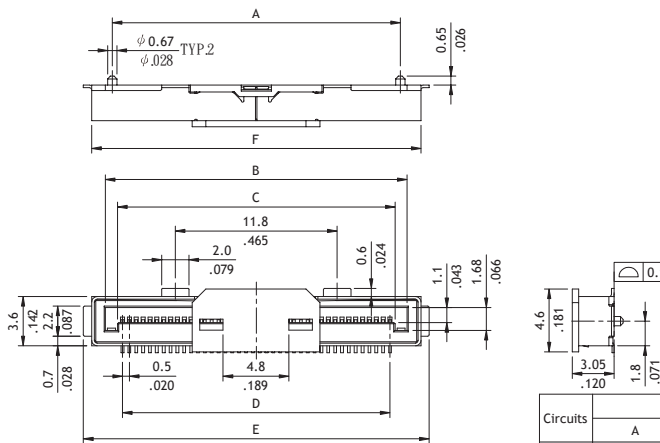

Circuits	Dimension							
	A	B	C	D	E	F	G	H
30	16.00(.630)	17.00(.670)	15.24(.600)	14.50(.571)	20.2(.795)	19.0(.748)	18.0(.709)	21.0(.827)
40	21.00(.827)	22.00(.866)	20.24(.797)	19.50(.758)	25.2(.992)	24.0(.945)	23.0(.906)	26.0(1.024)

**Ordering Code**

① CVS ② 5 ③ 40 ④ 2 ⑤ M ⑥ 1 ⑦ RA - NH

- ① Series No.
- ② No. of Circuits: 20, 30, 40
- ③ Plating Code:  
2 = Gold flash over Nickel  
\*Optional plating available but MOQ requested

- ④ M = SMT Type
- ⑤ Color: 1 = Black
- ⑥ Packing : R0 = Tape & Reel 2000PCS (20pin)  
RA = Tape & Reel 1250PCS (30,40pin)  
\*Special options consult manufacturer
- ⑦ NH = For Lead Free IR process and Halogen-Free

**CVSC Series 1.00mm(.039")H=2.35 LVDS Socket for TV / Monitor**

- ⊙ Connector Height 2.35mm
- ⊙ Board-to-cable for high density packaging
- ⊙ Polarization for preventing erroneous mating
- ⊙ Excellent in EMI shielding (With metal shell)
- ⊙ Insulation: High temperature plastic UL 94V-0, Color Nature
- ⊙ Contact: Phosphor Bronze
- ⊙ Ground: Phosphor Bronze
- ⊙ Shell: Phosphor Bronze



**RoHS** Compliant

P/N CVSC30DT0R0-NH

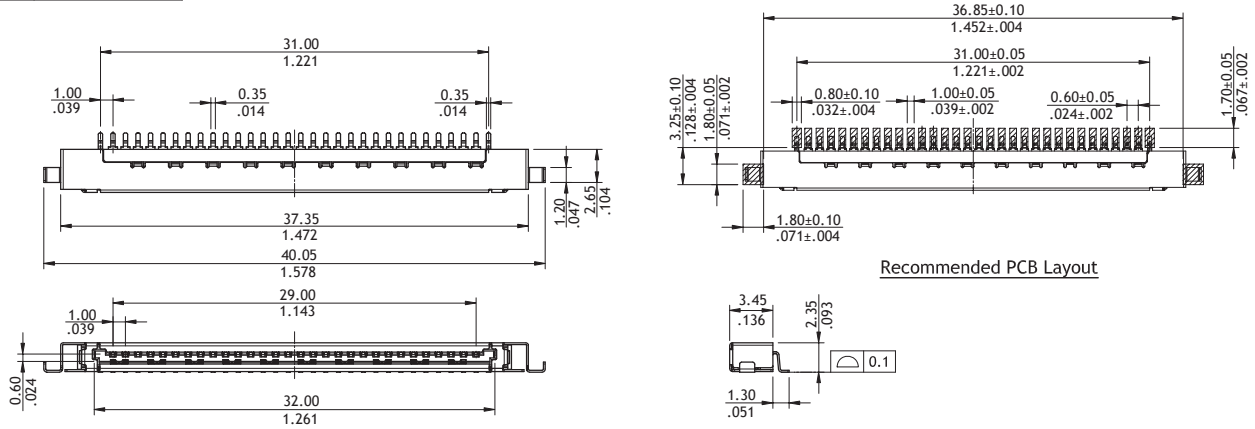

P/N CVSC30DB0R0-NH

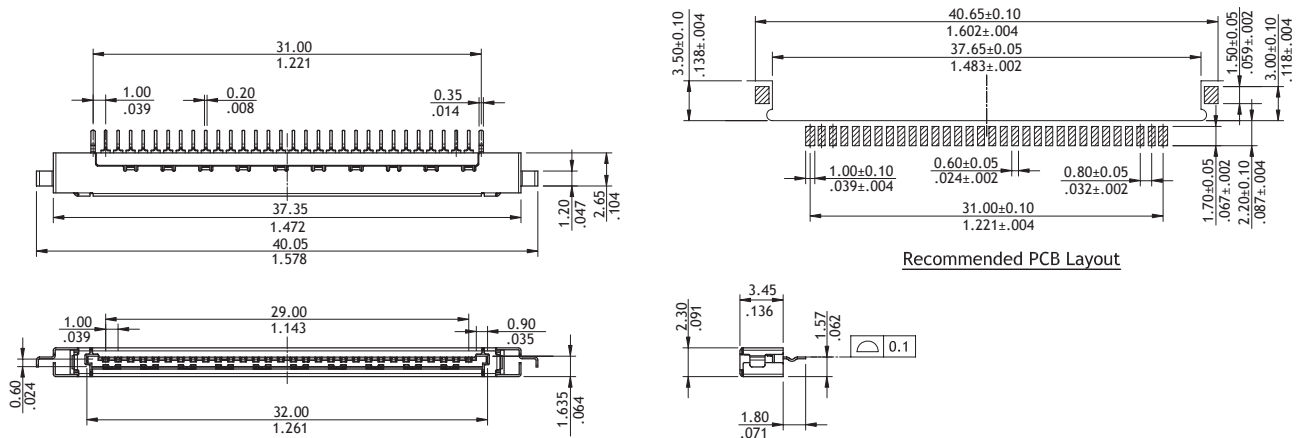

**Ordering Code**

① ② ③ ④ ⑤ ⑥ ⑦ ⑧  
**CVSC 30 D T 0 R 0 - NH**

- ① Series No.
- ② No. of Circuits: 30
- ③ Plating Code:  
D = Selective 10µ" Gold flash over Nickel
- ④ Contact Style:  
T = Top Mount  
B = Bottom Mount
- ⑤ Color: 0 = Nature
- ⑥ Packing :  
R = Tape & Reel
- ⑦ Other Options: 0 = Standard  
\*Special options consult manufacturer
- ⑧ NH = For Lead Free IR process and Halogen-Free

CVS

LVDS CONNECTOR

**CVSC Series 1.00mm(.039")H=2.35 LVDS Socket for TV / Monitor**

- ⊙ Connector Height 2.35mm
- ⊙ Board-to-cable for high density packaging
- ⊙ Polarization for preventing erroneous mating
- ⊙ Excellent in EMI shielding (With metal shell)
- ⊙ Insulation: High temperature plastic UL 94V-0, Color Nature
- ⊙ Contact: Phosphor Bronze
- ⊙ Ground: Phosphor Bronze
- ⊙ Shell: Phosphor Bronze

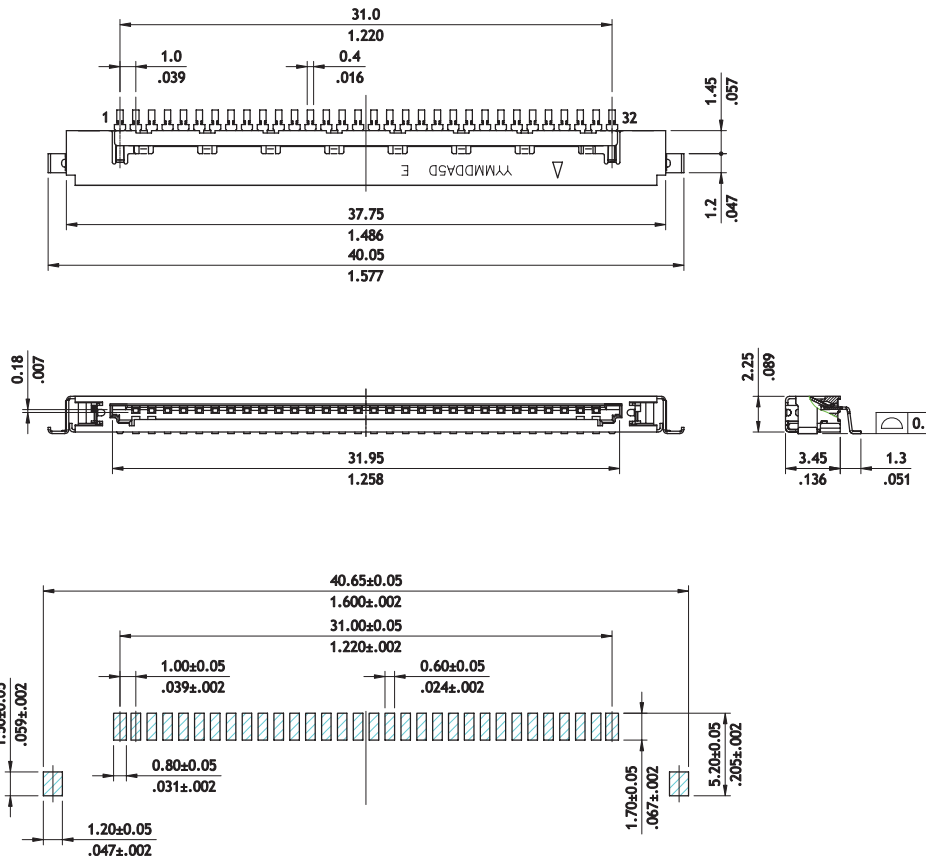

Recommended P.C. Board Layout

**Ordering Code**

① ② ③ ④ ⑤ ⑥ ⑦  
**CVSC 30 N T 0 RA - NH**

- ① Series No.
- ② No. of Circuits : 30
- ③ Plating Code:  
 N = Contact: 1μ"Gold plated over Nickel  
 Solderetails: Gold flash plated over Nickel
- ④ Contact Style:  
 T = Top Mount
- ⑤ Color: 0 = Nature
- ⑥ Packing: RA= Tape & Reel
- ⑦ NH = For Lead Free IR process and Halogen-Free

Connection Combination of Wire to Board Connectors

CI

0.80mm Right angle & Stranght SMT Type

0.80mm IDC Type Cable

0.80mm Right angle & Stranght SMT Type

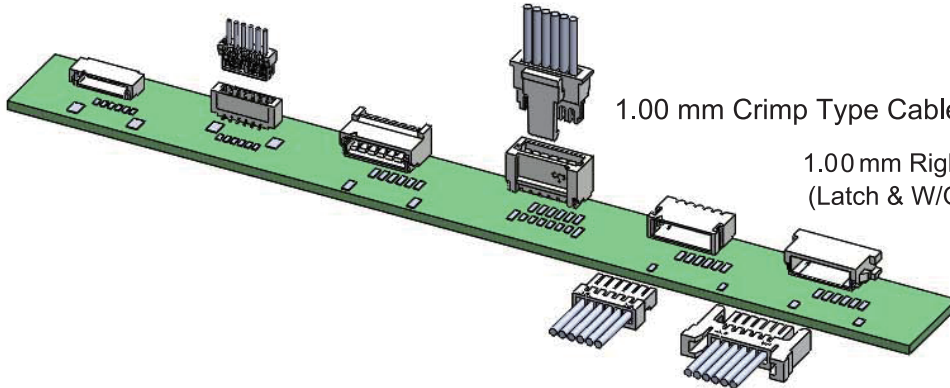

1.00 mm Crimp Type Cable

1.00 mm Right angle SMT Type (Latch & W/O Latch)

1.00mm Crimp Type Cable (Latch & W/O Latch)

1.20 mm Crimp Type Cable

1.50 mm Crimp Type Cable

0.60mm Right angle SMT

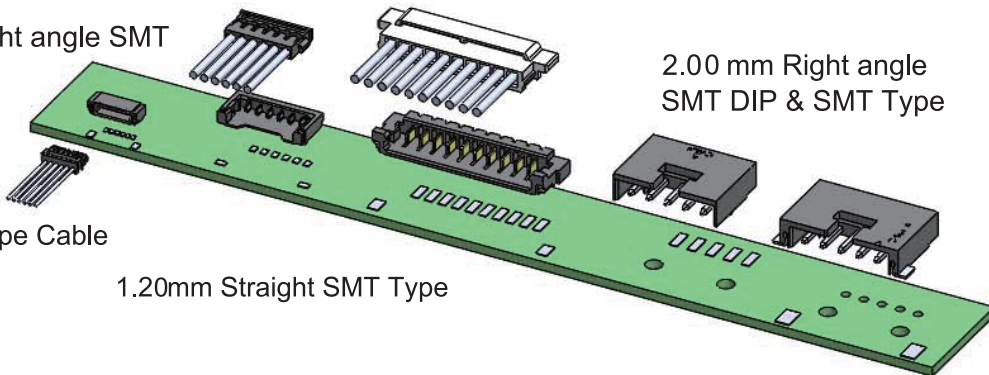

0.80mm IDC Type Cable

1.20mm Straight SMT Type

2.00 mm Right angle SMT DIP & SMT Type

1.50mm Straight SMT Type

2.00 Crimp Type Cable (Latch & W/O Latch)

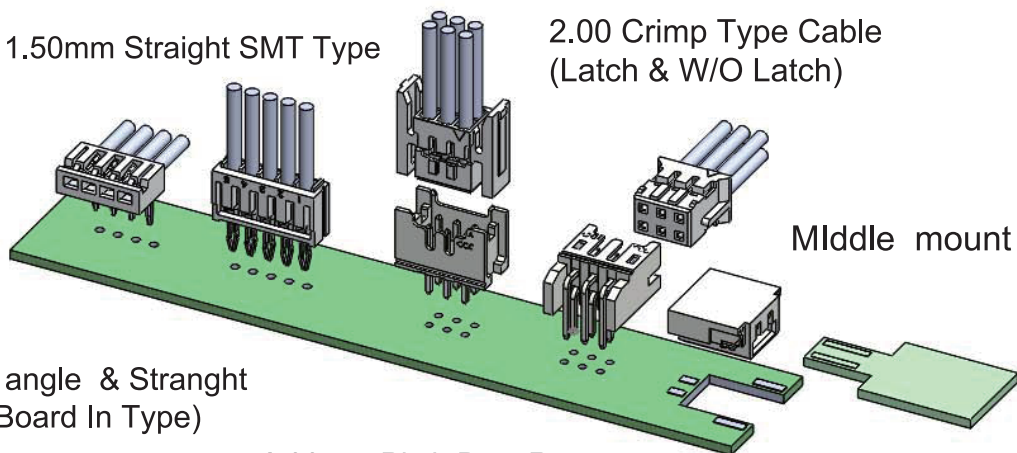

Middle mount Type

2.00mm Right angle & Stranght Crimp Cable (Board In Type)

2.00mm Pitch Dual Row Right angle & Stranght DIP Type (Latch & W/O Latch)

WIRE TO BOARD

**CI20 Series 0.60mm(.024") Wire to Board Housing & SMT Headers**

- ⊙ Fixed tabs provide PCB hold-down
- ⊙ Locking slots provide secure mating
- ⊙ Insulator: High temperature plastic UL 94V-0, Color Black
- ⊙ Applicable Wire: AWG #34 (Insulation O.D.: 0.32±0.02mm)

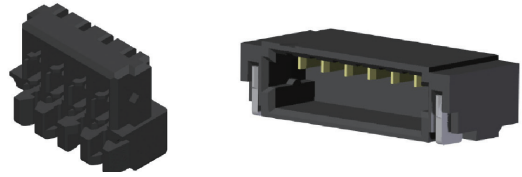

RoHS Compliant

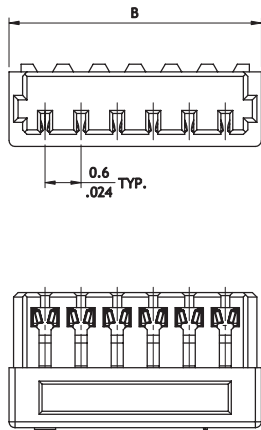

Circuits	Dim. B
4	3.0(.118)
5	3.6(.142)
6	4.2(.165)
7	4.8(.189)
8	5.4(.213)
10	6.6(.260)
12	7.8(.307)
14	9.0(.354)
16	10.2(.402)

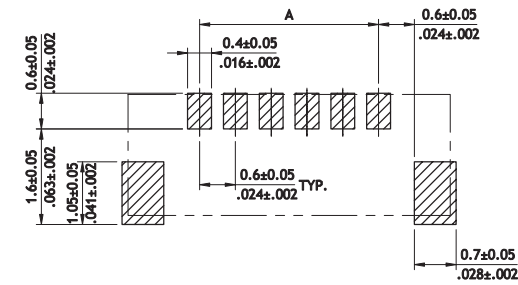
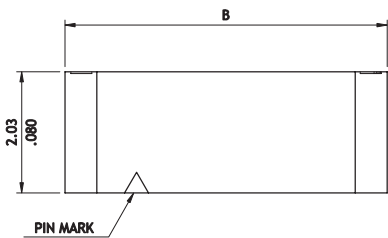
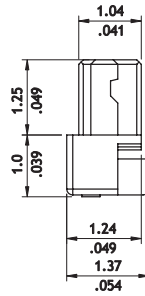

Recommended PCB Layout

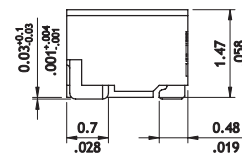
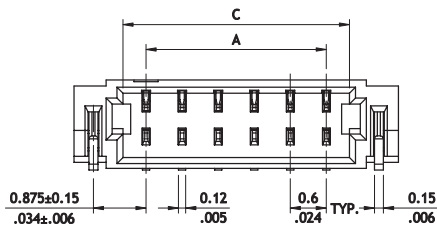

Circuits	Dimension		
	A	B	C
4	1.8(.071)	4.2(.165)	2.58(.102)
5	2.4(.094)	4.8(.189)	3.18(.125)
6	3.0(.118)	5.4(.213)	3.78(.149)
8	4.2(.165)	6.6(.260)	4.98(.196)
10	5.4(.216)	7.8(.307)	6.18(.243)
12	6.6(.260)	9.0(.354)	7.38(.291)

**Ordering Code**

① C ② 120 ③ 06 ④ S ⑤ 2 ⑥ 000 - NH

- ① Series No.
- ② No. of Circuits: 4~8,10,12,14,16
- ③ S = Housing
- ④ Plating Code : 2 = Gold flash over Nickel
- ⑤ Other Options: 000 = Standard
- ⑥ NH = For Halogen-Free

① C ② 120 ③ 06 ④ M ⑤ 2 ⑥ H ⑦ R ⑧ 0 - NH

- ① Series No.
- ② No. of Circuits: 6, 8, 10, 12
- ③ M = SMT Type
- ④ Plating Code: 2 = Gold flash over Nickel
- ⑤ Type: H = Side Entry
- ⑥ Packing Options: R = Tape & Reel
- ⑦ Other Options: 0 = Standard
- ⑧ NH = For Lead Free IR process and Halogen-Free

**CI18 Series 0.80mm(.031") Wire to Board Housing & SMT Headers**

- ⊙ Fixed tabs provide PCB hold-down
- ⊙ Insulator: High temperature plastic UL 94V-0, Color Nature
- ⊙ Housing: High temperature plastic UL 94V-0, Color Nature

RoHS Compliant 

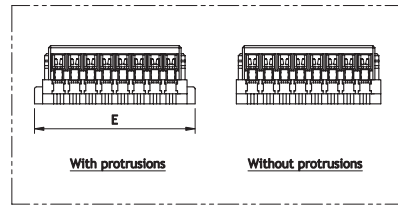
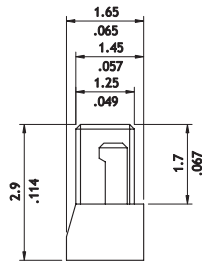
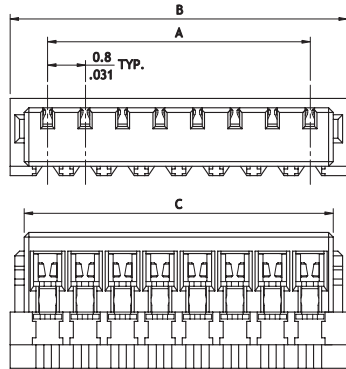
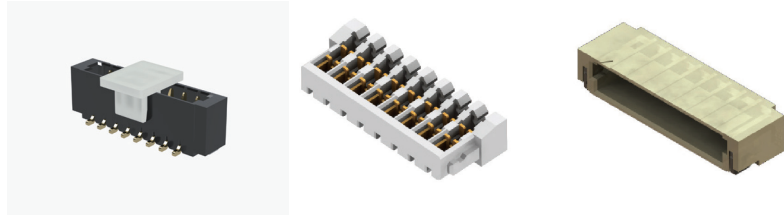

A = 0.8 x No. of Spaces  
 B = A + 1.6  
 C = A + 1.0  
 E = A + 2.4

Wire Range	Insulation Diameter
AWG #32	0.39 mm (.015)

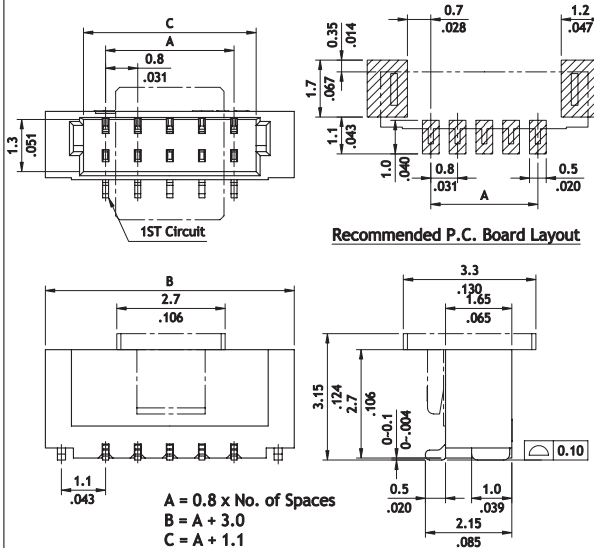
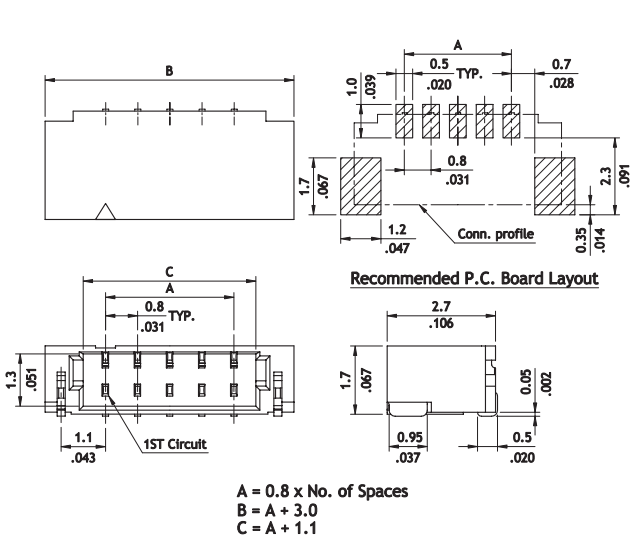

**Ordering Code**

① CI18 ② 15 ③ S ④ 2 ⑤ 000 - ⑥ NH

- ① Series No.
- ② No. of Circuits: 02 ~ 15
- ③ S = Housing
- ④ Plating Code:  
 1 = Matte Tin over Nickel  
 2 = Gold flash over Nickel
- ⑤ Other Options: 000 = AWG #32(Standard)  
 00A = AWG #36(with protrusions)
- ⑥ NH = For Lead Free and Halogen-Free

① CI18 ② 15 ③ M ④ 2 ⑤ H R ⑥ 0 - ⑦ NH

- ① Series No.
- ② No. of Circuits: 02 ~ 15
- ③ M = SMT Type
- ④ Plating Code: 1 = Matte Tin over Nickel  
 2 = Gold flash over Nickel
- ⑤ Type: V = Top Entry ; H = Side Entry
- ⑥ Packing Options: R = Tape & Reel
- ⑦ Other Options: 0 = Standard
- ⑧ NH = For Lead Free IR process and Halogen-Free

**C111 Series 1.00mm(.039") Single Row Wire to Board Housing & Terminal**

- ⊙ Insulator: Nylon 66 UL 94V-0, Color Nature
- ⊙ Terminal: Tin plated, Phosphor Bronze
- ⊙ Mate with C111 headers
- ⊙ Compact design
- ⊙ Protrusions design for easy pull out

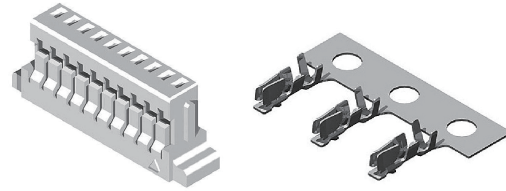

RoHS Compliant

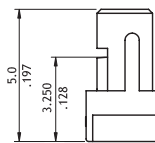
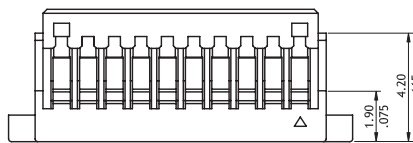
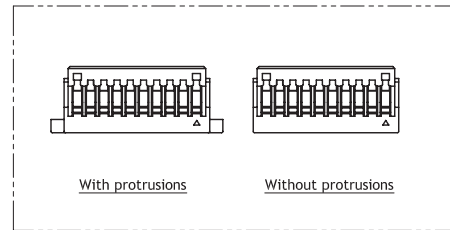
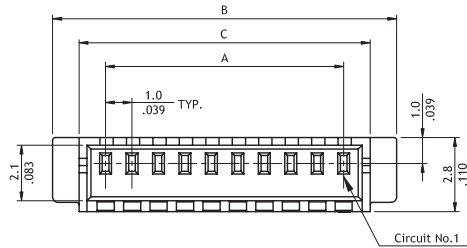

A = 1.0 x No. of Spaces  
 B = A + 4.0  
 C = A + 2.0

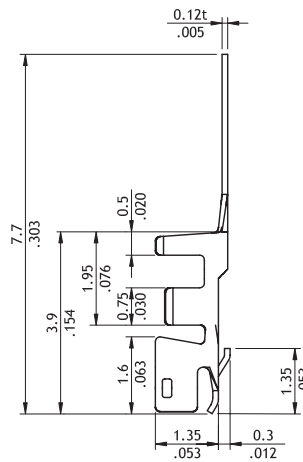
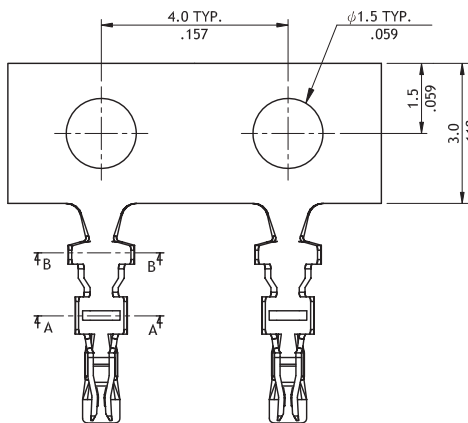

Wire Range	Insulation Diameter	Reel Qty
AWG #28-#32	0.4-0.8(mm) (.016-.031)	16,000 PCS

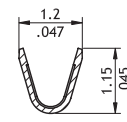
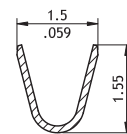

**Ordering Code**

① C111 ② 15 ③ S ④ 000 ⑤ 0 - ⑥ NH

- ① Series No.
- ② No. of Circuits: 02 ~ 15, 18, 20, 26
- ③ S = Housing
- ④ 000 = With Protrusions  
N00 = Without Protrusions
- ⑤ Other Options: 0 = Standard  
\*Special options consult manufacturer
- ⑥ NH =For Lead Free and Halogen-Free

① C111 ② T01 ③ 1 ④ P ⑤ P0

- ① Series No.
- ② Type: T01= AWG #28 ~ #32
- ③ Plating Code: 1 = Tin over Nickel
- ④ Material: P = Phosphor Bronze
- ⑤ Other Options: P0 = Standard

**C111 Series 1.00mm(.039") Single Row Wire to Board SMT Headers**

- ⊙ Polarization and Low-profile
- ⊙ Locking slots provide secure mating
- ⊙ Fixed tabs provide PCB hold-down
- ⊙ Mate with C111 housing
- ⊙ With Tin plated SMT type contact

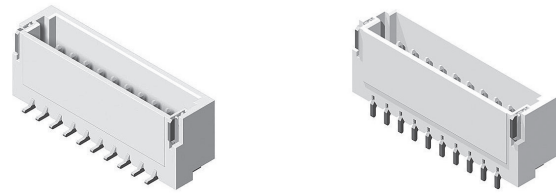

RoHS Compliant

CI

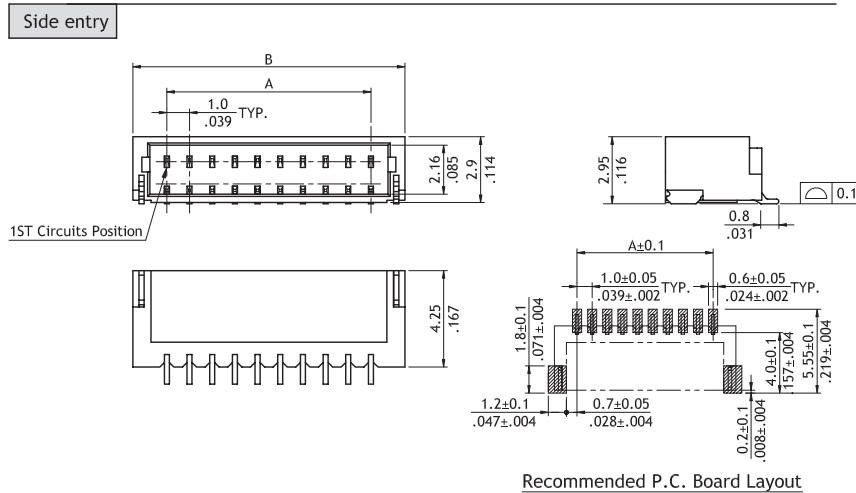
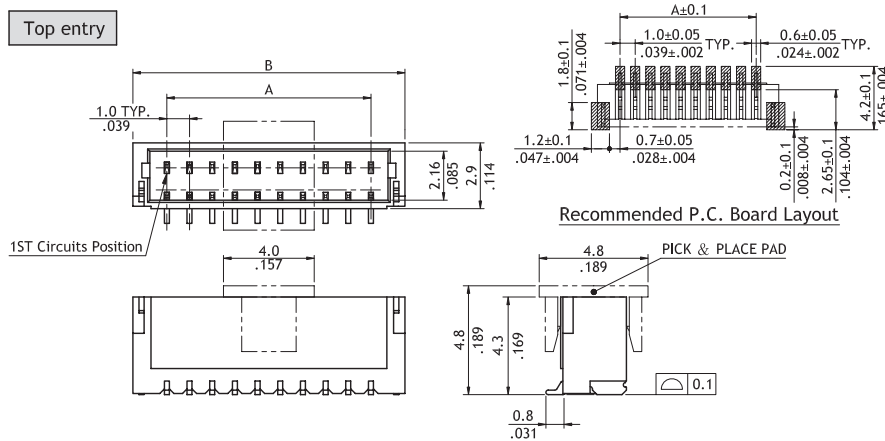

Circuits	Dimension	
	A	B
2	1.0(.039)	4.0(.157)
3	2.0(.079)	5.0(.197)
4	3.0(.118)	6.0(.236)
5	4.0(.157)	7.0(.276)
6	5.0(.197)	8.0(.315)
7	6.0(.236)	9.0(.354)
8	7.0(.276)	10.0(.394)
9	8.0(.315)	11.0(.433)
10	9.0(.354)	12.0(.472)
11	10.0(.394)	13.0(.512)
12	11.0(.433)	14.0(.551)
13	12.0(.472)	15.0(.591)
14	13.0(.512)	16.0(.630)
15	14.0(.551)	17.0(.669)
18	17.0(.669)	20.0(.787)
20	19.0(.748)	22.0(.866)
24	23.0(.906)	26.0(1.024)
26	25.0(.984)	28.0(1.102)

**Ordering Code**

① ② ③ ④ ⑤ ⑥ ⑦  
**C I 1 1 1 5 M 1 V R 0 - N H**

- ① Series No.
- ② No. of Circuits:  
02 ~ 15, 18, 20, 24, 26
- ③ M = SMT Type
- ④ Plating Code: 1 = Matte Tin over Nickel

- ⑤ Type : V = Top Entry  
H = Side Entry
- ⑥ Packing Options:  
R0 = Tape & Reel(Top entry type with pick & place pad)  
T0 = Tube
- ⑦ NH = For Lead Free and Halogen-Free

WIRE TO BOARD

**C111 Series 1.00mm(.039") Dual Row Wire to Board Housing & Terminal**

- ⊙ Insulator: Nylon 66 UL 94V-0, Color Nature
- ⊙ Terminal: Tin plated, Phosphor Bronze
- ⊙ Mate with C111 headers
- ⊙ Compact design
- ⊙ Protrusions design for easy pull out

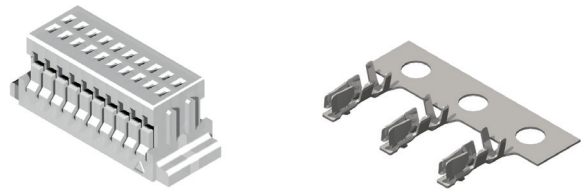

RoHS Compliant

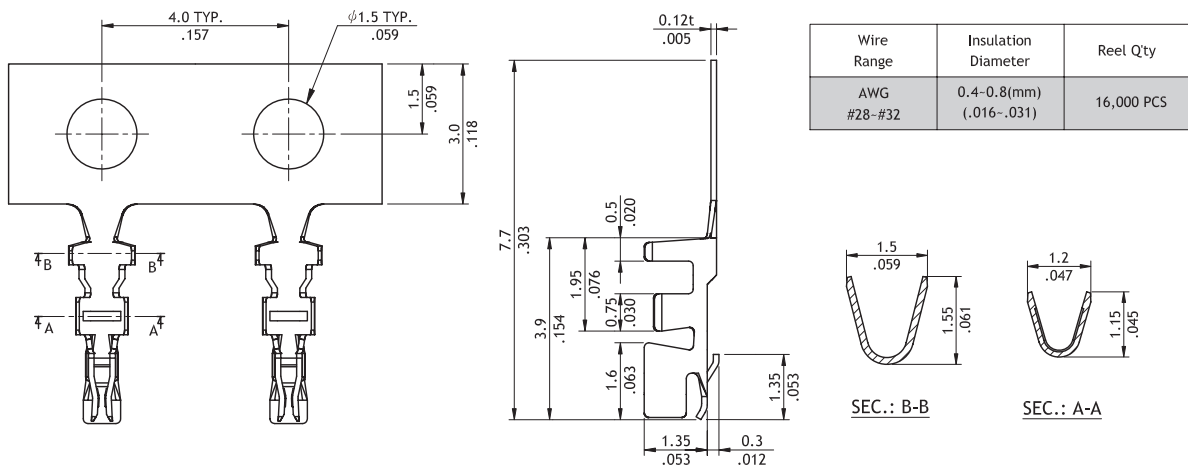
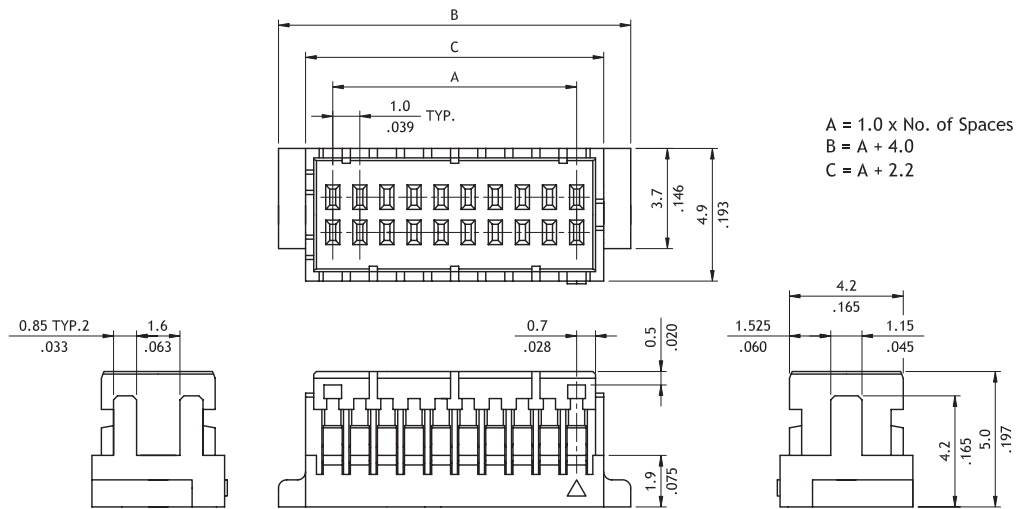

**Ordering Code**

① ② ③ ④ ⑤ ⑥

C 111 50 S D 000 - NH

① ② ③ ④ ⑤

C 111 T01 1 P PH

① Series No.  
 ② No. of Circuits: 10,12,14, 16, 20, 30, 40, 50  
 ③ S = Housing  
 ④ D=Dual Row Type  
 ⑤ Other Options: 000 = Standard  
 \*Special options consult manufacturer  
 ⑥ NH = For Halogen-Free

① Series No.  
 ② Type:T01= AWG #28-#32  
 ③ Plating Code: 1= Tin over Nickel  
 ④ Material: P=Phosphor Bronze  
 ⑤ Other Option:PH= Low Single contact force

**CI11 Series 1.00mm(.039") Dual Row Wire to Board SMT Headers**

- ⊙ Polarization and Low-profile
- ⊙ Locking slots provide secure mating
- ⊙ Fixed tabs provide PCB hold-down
- ⊙ With Tin plated SMT type contact

RoHS Compliant 

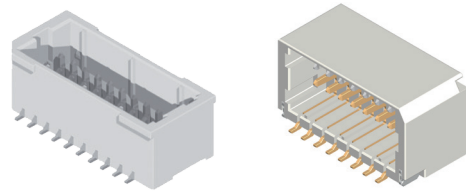

Top entry

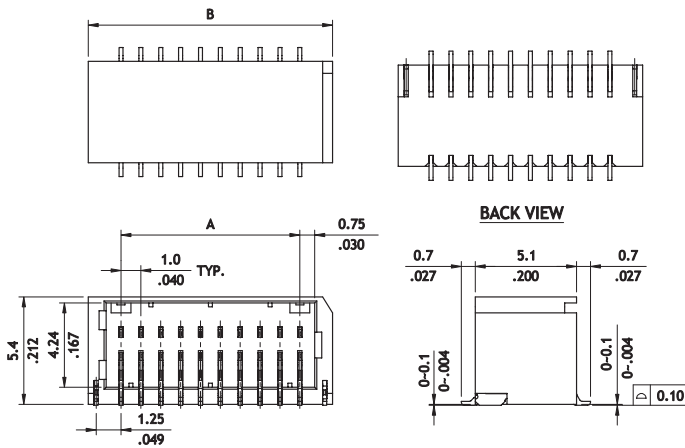

Circuits	Dimension	
	A	B
12	5.0(.197)	8.3(.327)
16	7.0(.276)	10.3(.406)
18	8.0(.315)	11.3(.445)
20	9.0(.354)	12.3(.484)
30	14.0(.551)	17.3(.681)
40	19.0(.748)	22.3(.878)
50	24.0(.945)	27.3(1.075)

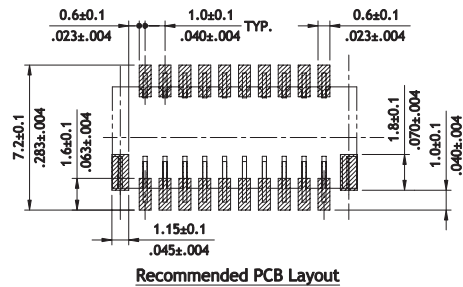

Side entry

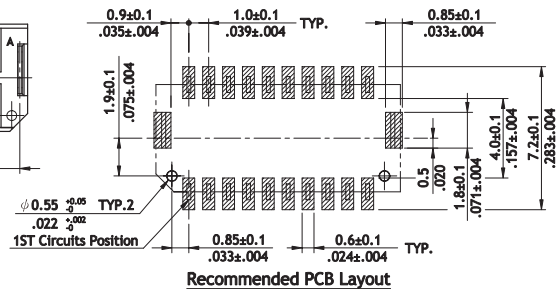
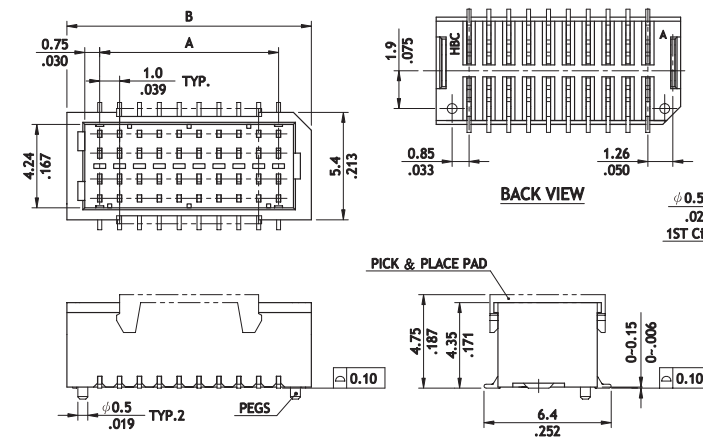

Circuits	Dimension	
	A	B
10	4.0(.157)	7.3(.287)
14	6.0(.236)	9.3(.366)
16	7.0(.276)	10.3(.406)
20	9.0(.354)	12.3(.484)
24	11.0(.433)	14.3(.681)
30	14.0(.511)	17.3(.681)
40	19.0(.748)	22.3(.878)
50	24.0(.945)	27.3(1.075)

**Ordering Code**

① CI11    ② 50    ③ M    ④ 2    ⑤ V    ⑥ D    ⑦ 0    ⑧ -R0    ⑨ -NH

- ① Series No.
- ② No. of Circuits:  
Top Entry: 10,14,16,20,24,30,40,50  
Side Entry: 12,16,18,20,30,40,50  
\*see above table
- ③ M = SMT Type
- ④ Plating Code:  
2 = Gold flash over Nickel
- ⑤ Type: V = Top Entry  
H = Side Entry
- ⑥ D = Dual Row type
- ⑦ Pegs Options:  
Top Entry: 0 = With Pegs(Standard)  
1 = Without Peg  
Side Entry: 0 = Standard
- ⑧ Packing Options:  
R0 = Tape & Reel  
T0 = Tube
- ⑨ NH = For Lead Free IR process and Halogen-Free

**Series 1.00mm(.039") Wire to Board Connectors Housing & Terminal**

- ⊙ Mate with CI16 header
- ⊙ Can be used with CI16 crimp clip terminal
- ⊙ Insulator: Nylon 66 UL 94V-0, Color Nature



RoHS Compliant

P/N CI16\*\*SL00A-NH

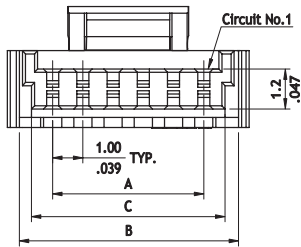

DIM. A = 1.00 x No. of Spaces  
 DIM. B = DIM. A + 2.20  
 DIM. C = DIM. A + 1.50

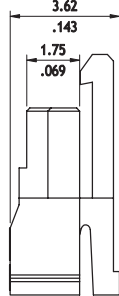
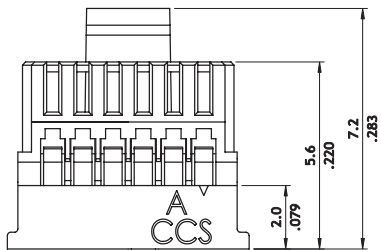

P/N CI16\*\*SL000-NH

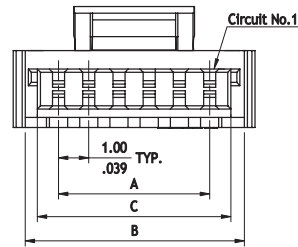

DIM. A = 1.00 x No. of Spaces  
 DIM. B = DIM. A + 2.00  
 DIM. C = DIM. A + 1.50

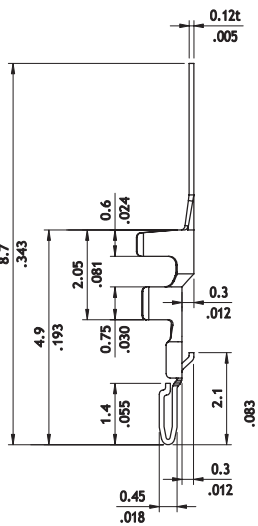
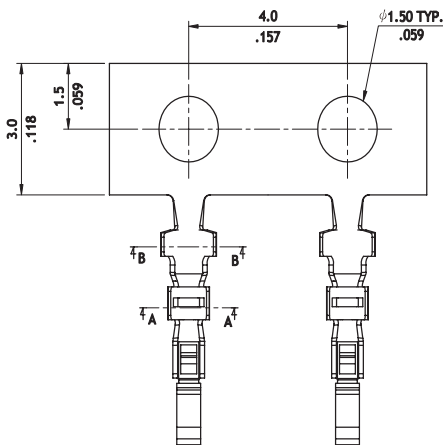
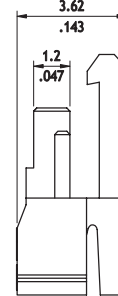
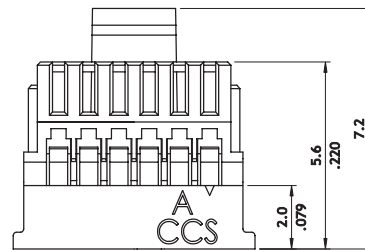

Wire Range	Insulation Diameter	Reel Qty
AWG #28-#32	0.78-0.92(mm) (.031-.036)	16,000 PCS.

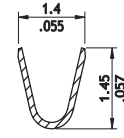
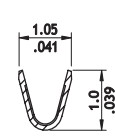

**Ordering Code**

① CI16 ② 20 ③ S ④ L ⑤ 00A - ⑥ NH

- ① Series No.
- ② No. of Circuits: 02 ~ 20
- ③ S = Connector housing
- ④ L=With Locking Latch
- ⑤ Other Options: 00A =Type 1 (Standard)  
000 =Type 2
- ⑥ NH = For Halogen-Free

① C16 ② T01 ③ 1 ④ P ⑤ E0

- ① Series No.
- ② Type:T01= AWG #28-#32
- ③ Plating Code: 1= Tin over Nickel
- ④ Material: P=Phosphor Bronze
- ⑤ Other Option: E0=Standard

CI

WIRE TO BOARD

**C116 Series 1.00mm(.039") Wire to Board Connectors SMT Headers**

- ⊙ Fixed tabs provide PCB hold-down
- ⊙ Mate with C116 housing
- ⊙ Insulator: High temperature plastic UL 94V-0, Color Nature
- ⊙ Terminal: Tin plated Phosphor Bronze

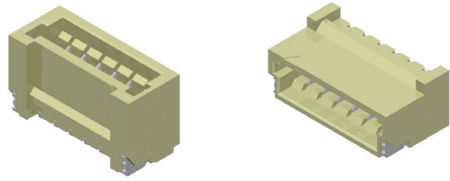

RoHS Compliant

CI

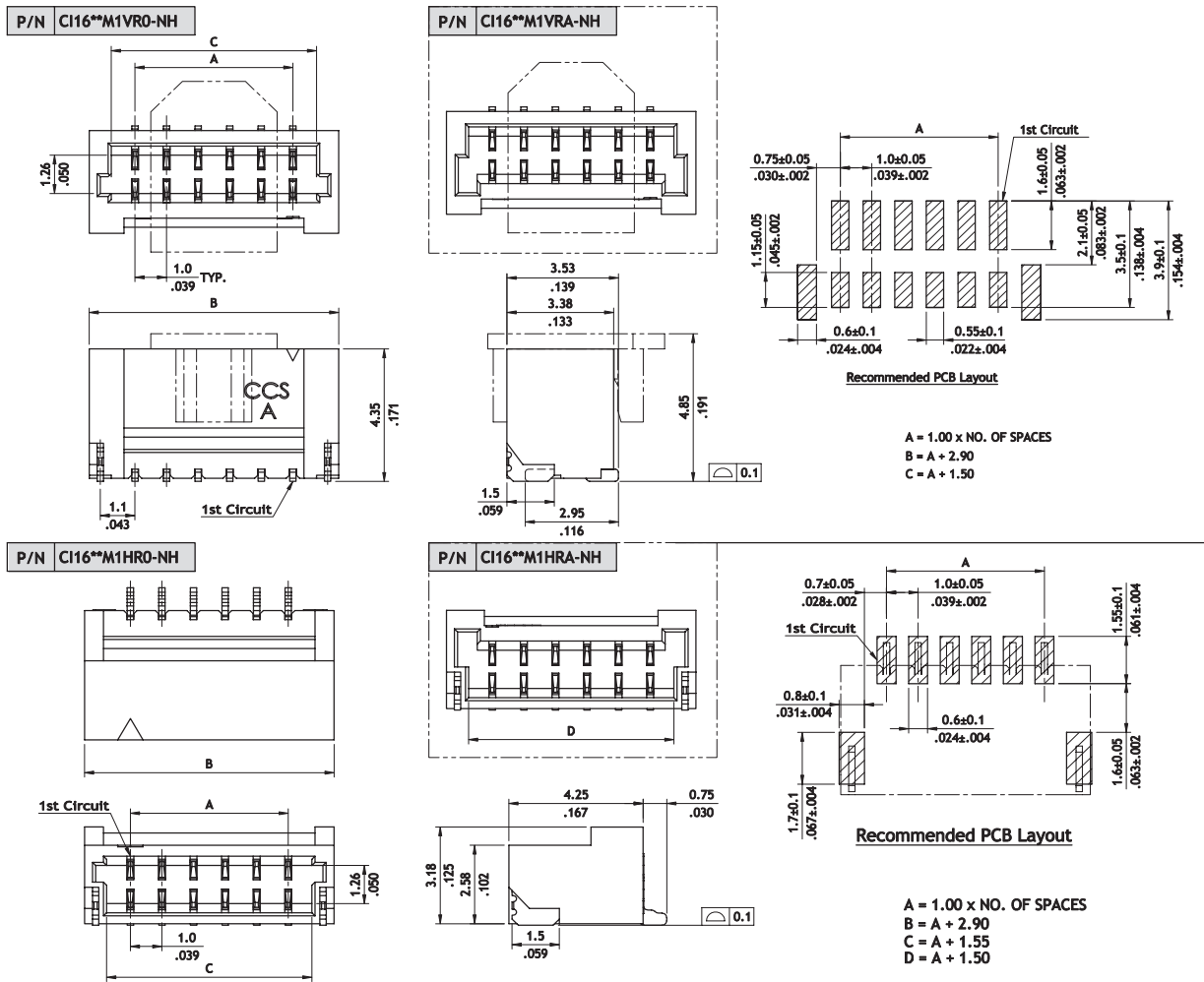

**Ordering Code**

① C ② 16 ③ 20 ④ M ⑤ 1 ⑥ V ⑦ R ⑧ A - NH

- ① Series No.
- ② No. of Circuits: 02 ~ 20
- ③ M = SMT Type
- ④ Plating Code: 1 = Matte Tin over Nickel
- ⑤ Type: V = Top Entry  
H = Side Entry
- ⑥ Packing Options: R = Tape & Reel
- ⑦ Other Option: A = Type 1 (Standard)  
0 = Type 2
- ⑧ NH = For Lead Free IR Process and Halogen-Free

WIRE TO BOARD

**C114 Series 1.00mm(.039") Wire to Board Connectors Housing & Terminal**

- ⊙ Mate with C114 Header
- ⊙ Can be used with C114 crimp clip terminal
- ⊙ Insulator: Glass filled polyester or Nylon 66 UL 94V-0, Color Nature
- ⊙ Terminal: Tin plated Phosphor Bronze

RoHS Compliant

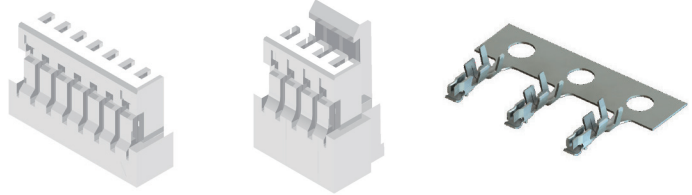

Without Latch Type

With Latch Type

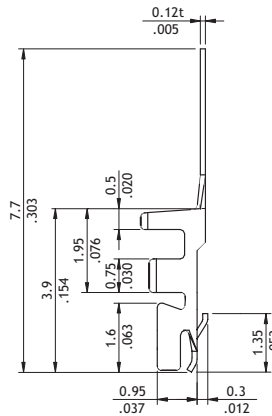
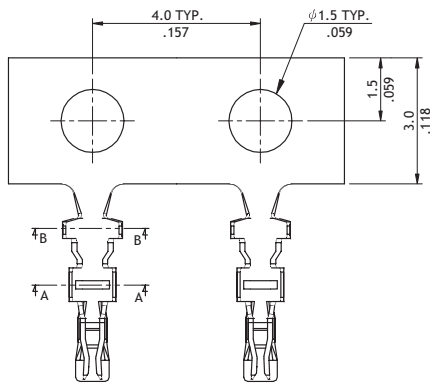
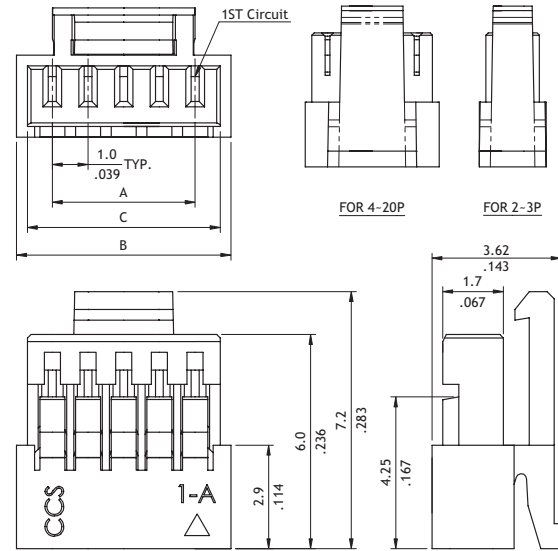
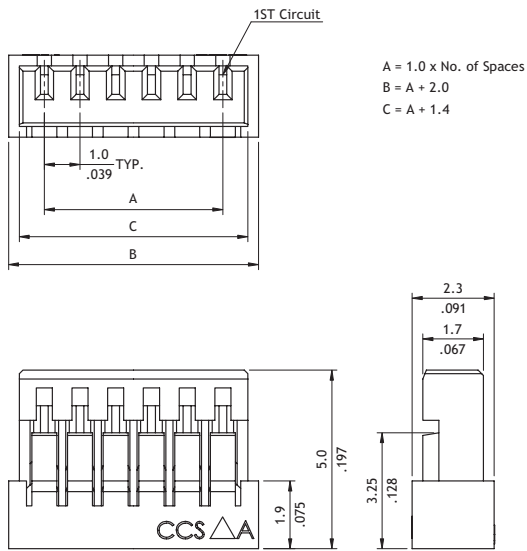

Wire Range	Insulation Diameter	Reel Q'ty
AWG #28-#32	0.65-0.92(mm) (.026-.036)	16,000 PCS.

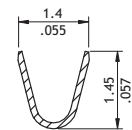
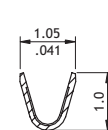

**Ordering Code**

① C114    ② 20    ③ S    ④ 000A - NH

① C114    ② T01    ③ 1    ④ P    ⑤ E0

- ① Series No.
- ② No. of Circuits: 02 ~ 20
- ③ S = Housing
- ④ 000A=Without Locking Latch  
L000=With Locking Latch
- ⑤ NH = For Halogen-Free

- ① Series No.
- ② Type:T01= AWG #28-#32
- ③ Plating Code: 1= Tin over Nickel
- ④ Material: P=Phosphor Bronze
- ⑤ Other Option: E0=Standard

**CI14 Series 1.00mm(.039") Wire to Board SMT Side Entry Headers**

- ⊙ Fixed tabs provide PCB hold-down
- ⊙ Mate with CI14 Housing
- ⊙ Insulator : High temperature plastic UL 94V-0, Color Nature

RoHS Compliant 

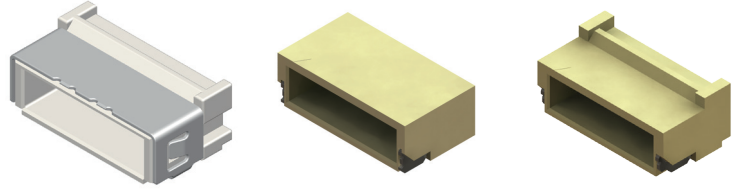

CI

P/N CI14\*\*M1HRC-NH

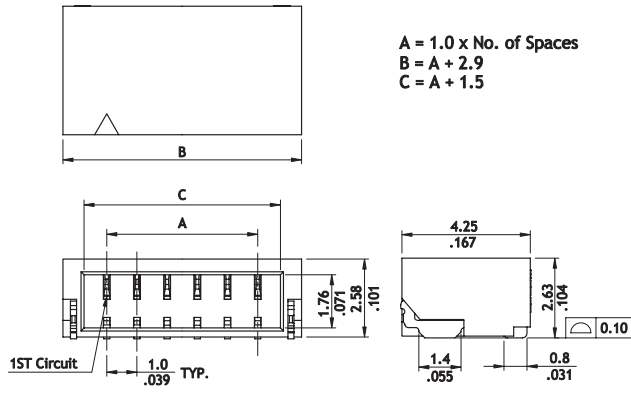

P/N CI14\*\*M1HRE-NH

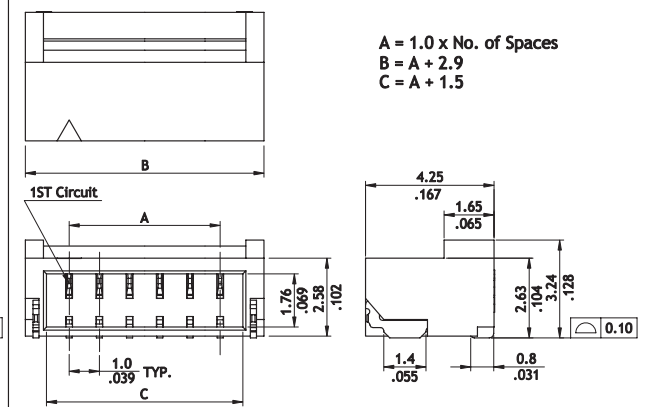

P/N CI14\*\*M1HRN-NH

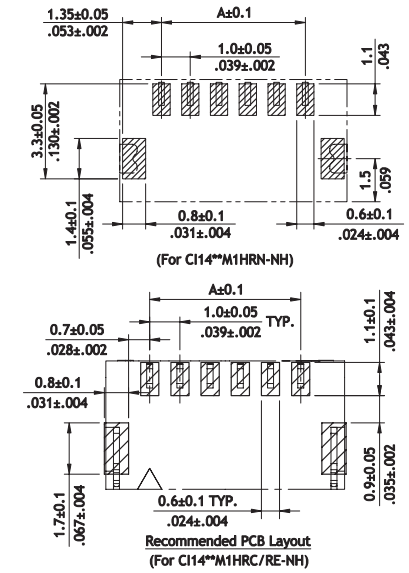
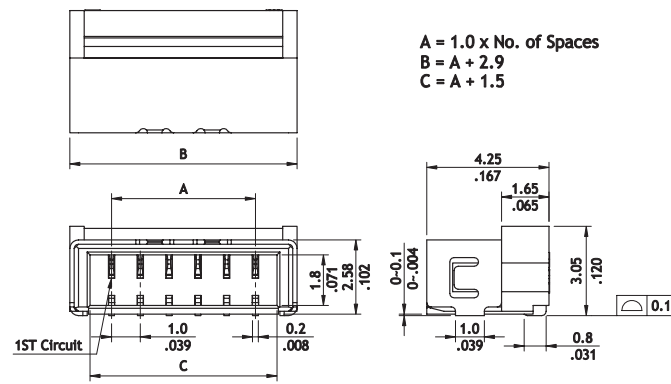

WIRE TO BOARD

**CI14 Series 1.00mm(.039") Wire to Board SMT Side Headers**

- ⊙ Fixed tabs provide PCB hold-down
- ⊙ Mating with CI14 Housing
- ⊙ Insulator: High temperature plastic UL 94V-0, color Nature

RoHS Compliant

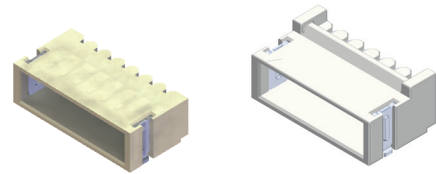

P/N CI14\*\*M1HR0-NH

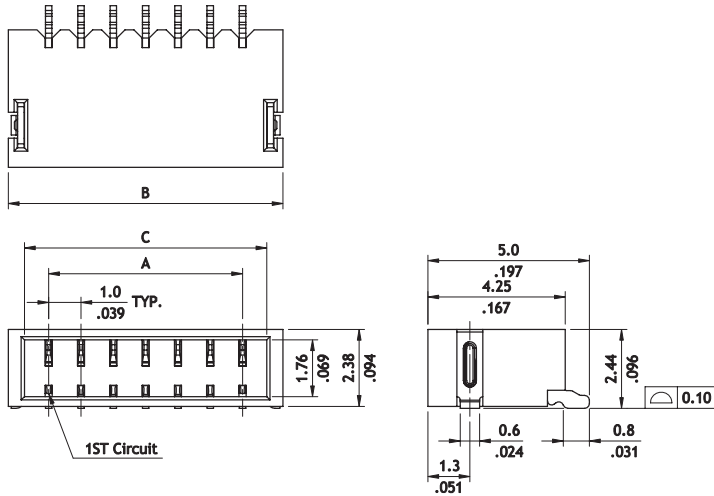

Circuits	Dimension		
	A	B	C
2	1.0(.039)	3.5(.138)	2.5(.098)
3	2.0(.079)	4.5(.177)	3.5(.138)
4	3.0(.118)	5.5(.216)	4.5(.177)
5	4.0(.157)	6.5(.256)	5.5(.216)
6	5.0(.197)	7.5(.295)	6.5(.256)
7	6.0(.236)	8.5(.335)	7.5(.295)
8	7.0(.276)	9.5(.374)	8.5(.335)
9	8.0(.315)	10.5(.413)	9.5(.374)
10	9.0(.354)	11.5(.453)	10.5(.413)
11	10.0(.394)	12.5(.492)	11.5(.453)
12	11.0(.433)	13.5(.531)	12.5(.492)
13	12.0(.472)	14.5(.571)	13.5(.531)
14	13.0(.512)	15.5(.610)	14.5(.571)
15	14.0(.551)	16.5(.650)	15.5(.610)
16	15.0(.590)	17.5(.689)	16.5(.650)
17	16.0(.630)	18.5(.728)	17.5(.689)
18	17.0(.669)	19.5(.768)	18.5(.728)
19	18.0(.709)	20.5(.807)	19.5(.768)
20	19.0(.748)	21.5(.846)	20.5(.807)

P/N CI14\*\*M1HRL-NH

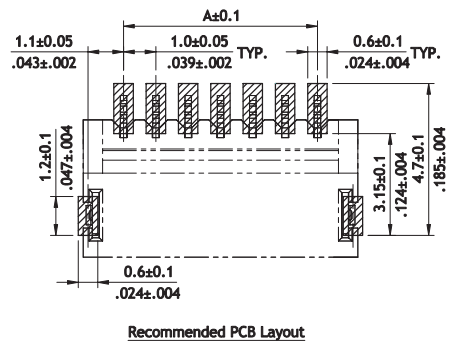
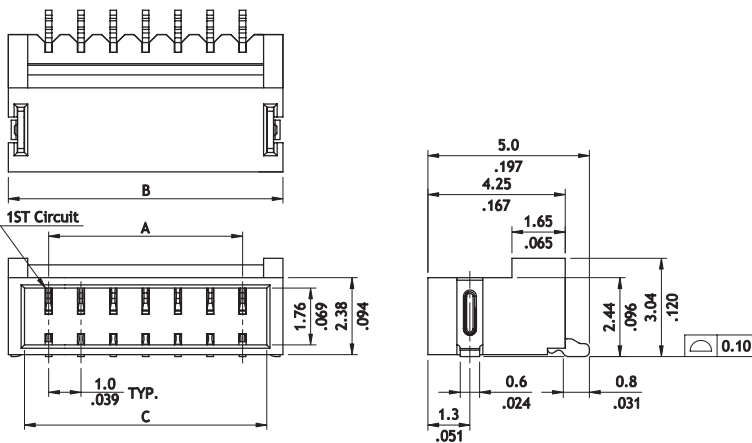

**Ordering Code**

①
②
③
④
⑤
⑥
CI14
03
S
L
00C
-NH

①
②
③
④
⑤
⑥
⑦
⑧
CI14
03
M
1
H
R
I
-NH

- ① Series No.
- ② No. of Circuits: 03 ~ 20
- ③ S= Housing
- ④ L=With Locking Latch
- ⑤ Other Option: 00C = Latch Type 2
- ⑥ NH = For Lead Free and Halogen-Free
- ① Series No.
- ② No. of Circuits: 03 ~ 20
- ③ M = SMT Type
- ④ Plating Code: 1 = Matte Tin over Nickel
- ⑤ Type: H = Side Entry
- ⑥ Packing Options: R = Tape & Reel
- ⑦ Other Options: I = Dual Latch Type
- ⑧ NH = For Lead Free IR process and Halogen-Free

CI14 Series 1.00mm(.039") Wire to Board SMT Top Entry Headers

- ⊙ Fixed tabs provide PCB hold-down
- ⊙ Mating with CI14 Housing
- ⊙ Insulator: High temperature plastic UL 94V-0, color Nature

RoHS Compliant 

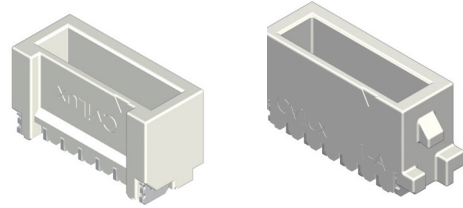

P/N CI14\*\*M1VL0-NH

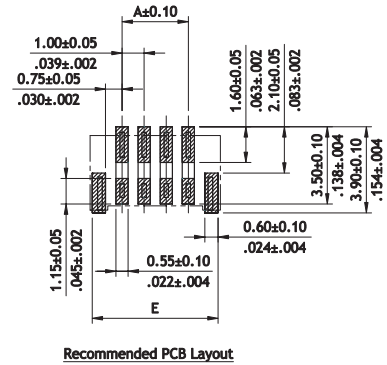
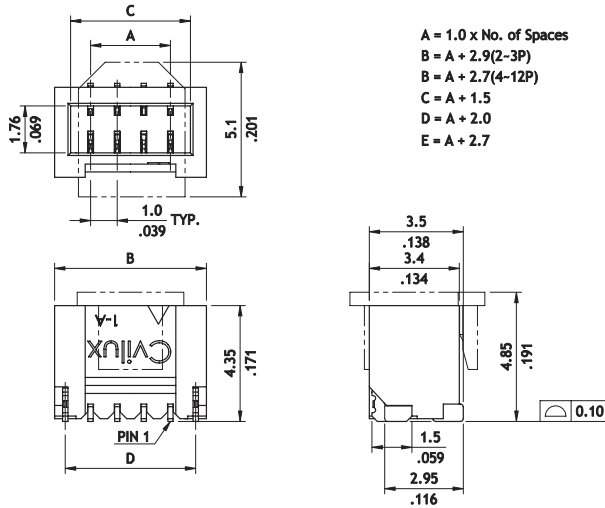

P/N CI14\*\*M1VLB-NH

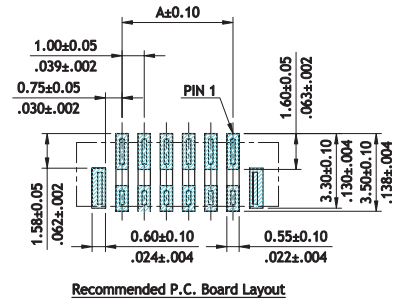
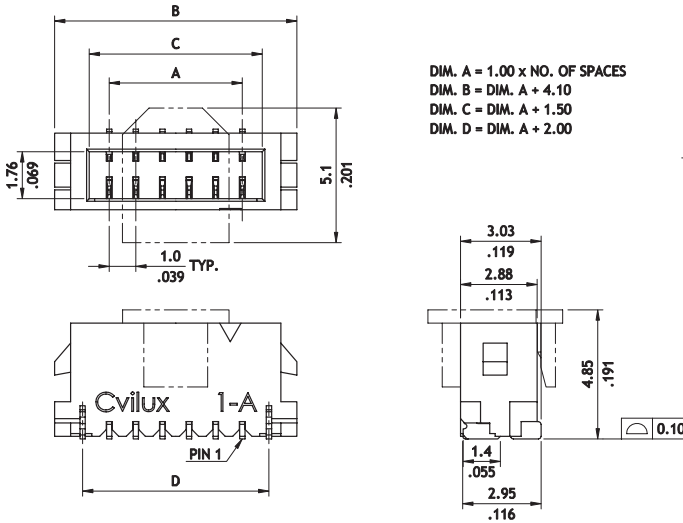

Ordering Code

① ② ③ ④ ⑤ ⑥ ⑦  
**CI14 12 M 1 V L0 - NH**

- ① Series No.
- ② No. of Circuits: 2~12
- ③ M = SMT Type
- ④ Plating Code: 1 = Matte Tin over Nickel
- ⑤ Type: V = Top Entry
- ⑥ Other Options:  
 L0 = Locking Type with Reel Packing  
 LB = Dual latch type
- ⑦ NH = For Lead Free IR process and Halogen-Free

**C114 Series 1.00mm(.039") Wire to Board Housing & SMT Side Entry Header**

- ⊙ Can be used C114 crimp clip terminal
- ⊙ Insulator: High temperature plastic UL 94V-0, Color Nature
- ⊙ Insulator: Nylon 66 UL 94V-0, Color Nature
- ⊙ With locking latch provide secure mating

RoHS Compliant

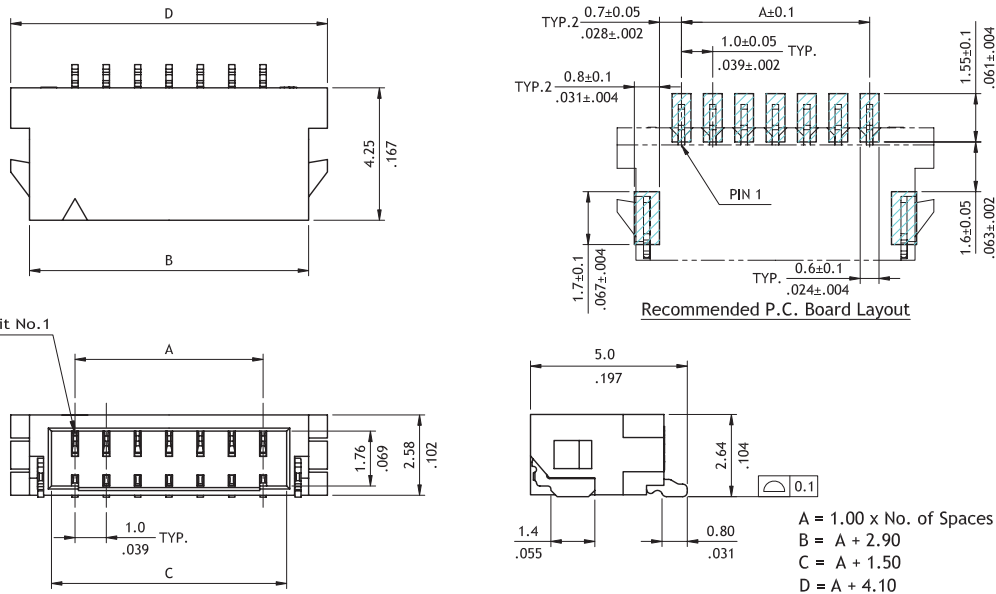
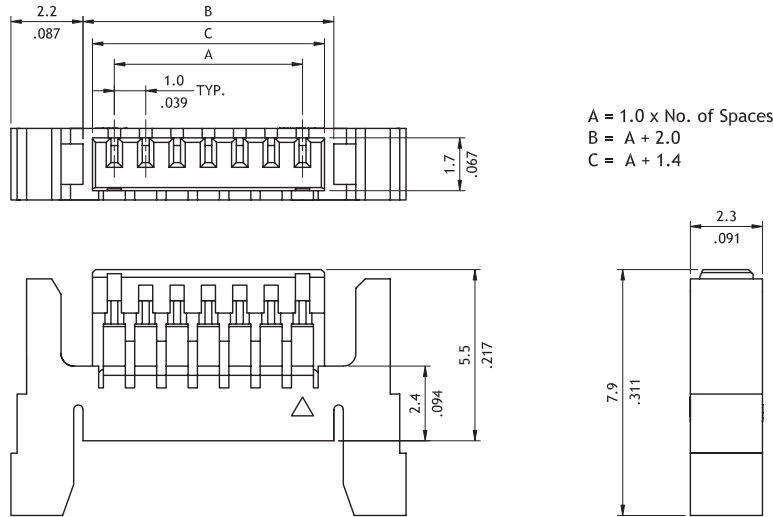
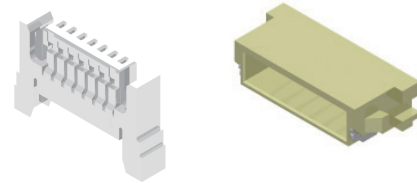

Ordering Code						Ordering Code											
①	②	③	④	⑤	⑥	①	②	③	④	⑤	⑥	⑦	⑧				
C	14	03	S	L	00C	-	NH	C	14	03	M	1	H	R	I	-	NH
① Series No.	② No. of Circuits: 03 ~ 20	③ S= Housing	④ L=With Locking Latch	⑤ Other Option: 00C = Latch Type 2	⑥ NH = For Lead Free and Halogen-Free	① Series No.	② No. of Circuits: 03 ~ 20	③ M = SMT Type	④ Plating Code: 1 = Matte Tin over Nickel	⑤ Type: H = Side Entry	⑥ Packing Options: R = Tape & Reel	⑦ Other Options: I = Dual Latch Type	⑧ NH = For Lead Free IR process and Halogen-Free				

**CI63 Series 1.20mm(.048") Wire to Board Housing / Terminal**

- ⊙ Mate with CI63 Header
- ⊙ Can be used with CI63 crimp clip terminal
- ⊙ Insulation: High temperature plastic UL 94V-0, Color Black

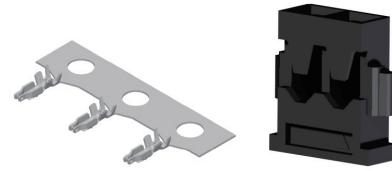

RoHS Compliant

CI

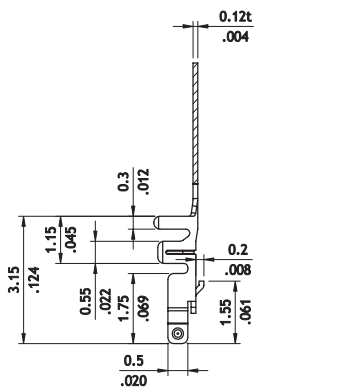
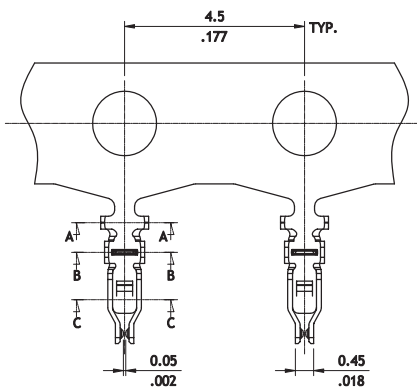
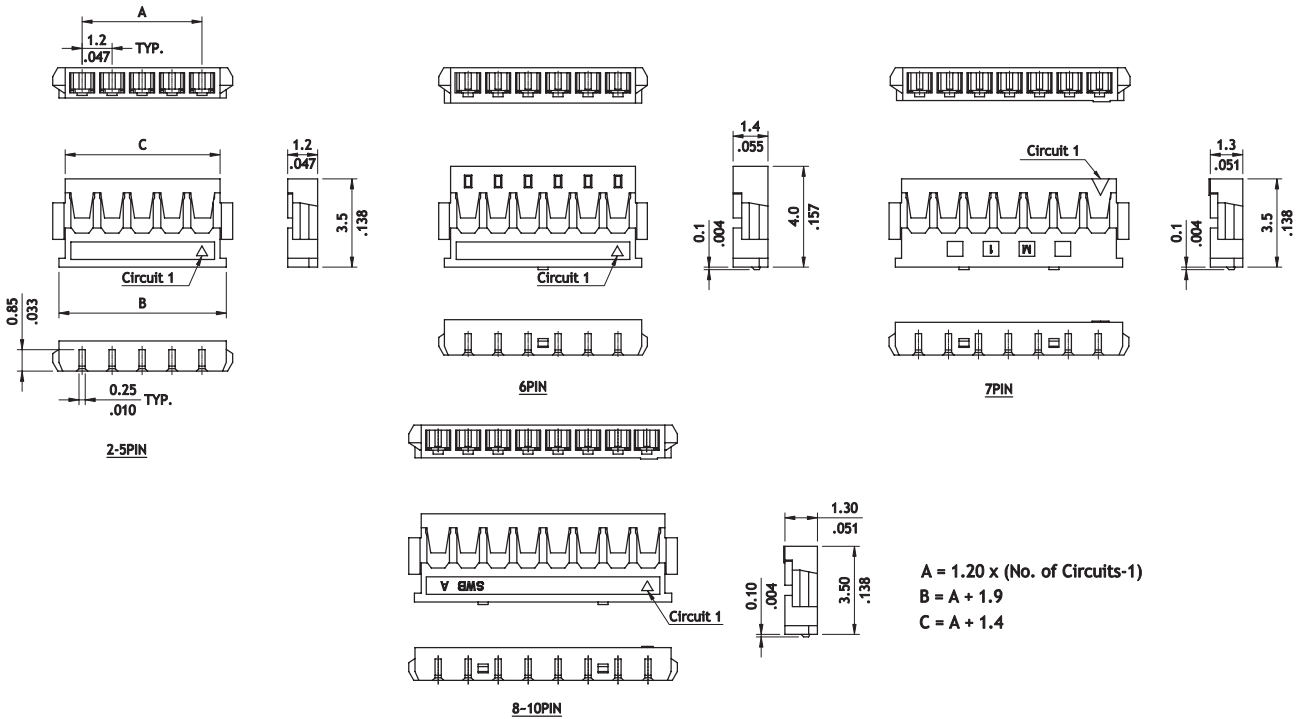

Wire Range	Insulation Diameter	Reel Qty
AWG #28-#30	0.70 (.028) MAX.	15,000 PCS.

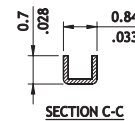
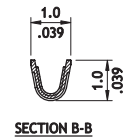
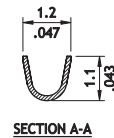

**Ordering Code**

① CI63 ② 07 ③ S ④ 0000

① CI63 ② T01 ③ 2 ④ P ⑤ P0

- ① Series No.
- ② No. of Circuits: 02 ~ 10
- ③ S = Housing
- ④ Other Options: 0000 = Standard

- ① Series No.
- ② Type: T01=AWG #28~ #30
- ③ Plating : 2 = Gold flash over Nickel
- ④ Material : P=Phosphor Bronze
- ⑤ Option : P0 =Standard

WIRE TO BOARD

**CI63 Series 1.20mm(.048") Wire to Board SMT Headers**

- ⊙ Mate with CI63 Housing
- ⊙ Insulation: High temperature plastic UL 94V-0,
- ⊙ Color Black

RoHS Compliant

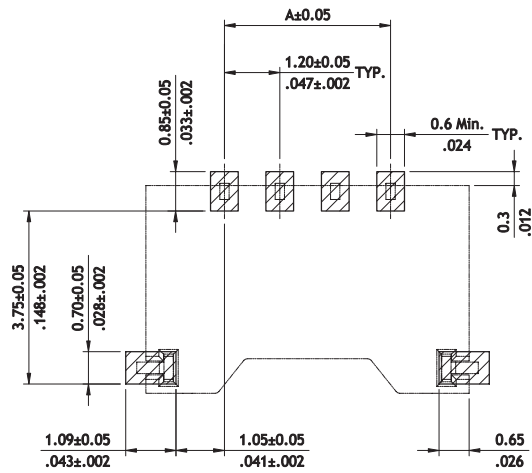
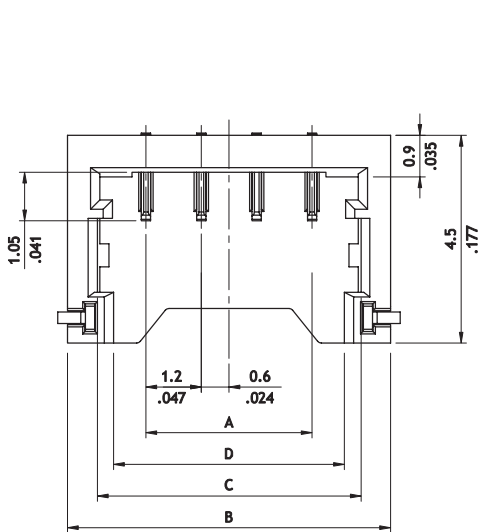
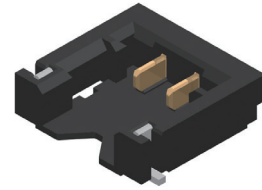

Recommended PCB Layout

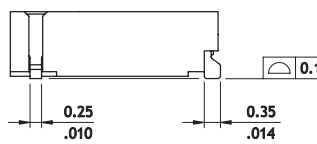
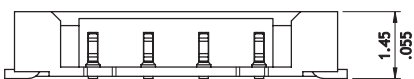

- A = 1.20 x (No. of Circuits-1)
- B = A + 3.4
- C = A + 2.1
- D = A + 1.4

**Ordering Code**

① CI63 ② 10 ③ M ④ 2 ⑤ V ⑥ R ⑦ 0 - ⑧ NH

- ① Series No.
- ② No. of Circuits: 2 ~ 6 ,8,10
- ③ Solder Type: M = SMT
- ④ Plating Code: 2 = Gold flash over Nickel
- ⑤ Type: V = Top Entry
- ⑥ Packing Options: R = Tape & Reel Packing
- ⑦ Other Option: 0 = Standard
- ⑧ NH = For Lead Free IR process and Halogen-Free

**CI40 Series 1.25mm(.049") Wire to Board SMT Header**

- ⊙ Locking slots provide secure mating
- ⊙ Fixed tab PCB hold-down and strain-relief for SMT tail
- ⊙ Insulator: High temperature plastic UL 94V-0, Color Nature

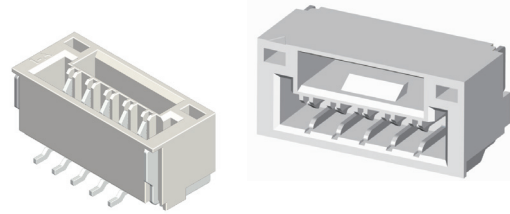

P/N CI40\*\*M\*\*HRA-NH

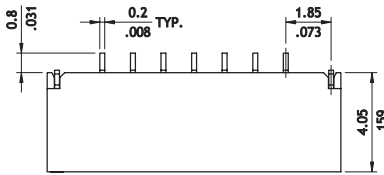

A = 1.25 x No. of Spaces  
 B = A + 4.50  
 C = A + 2.60

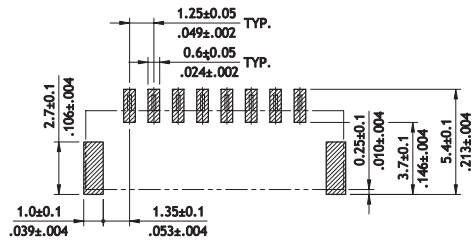

Recommended PCB Layout

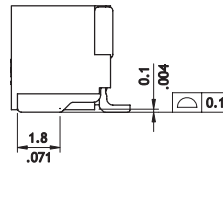
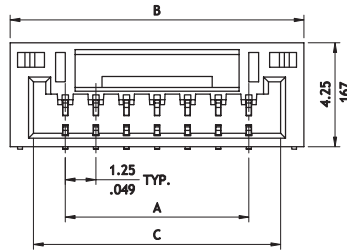

P/N CI40\*\*M\*\*VRA-NH

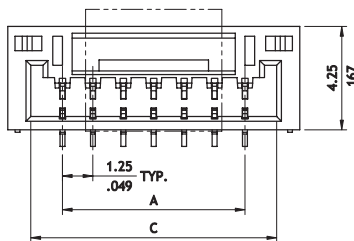

A = 1.25 x No. of Spaces  
 B = A + 4.50  
 C = A + 2.60

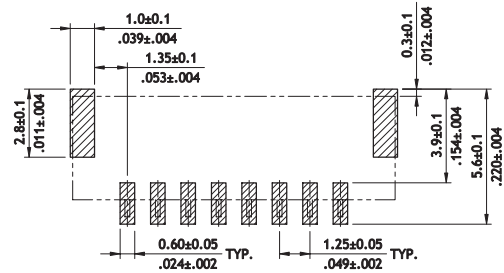

Recommended PCB Layout

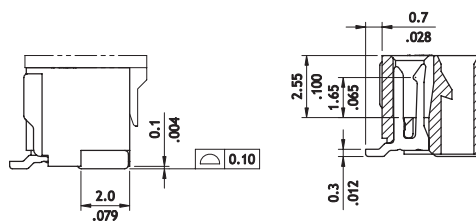
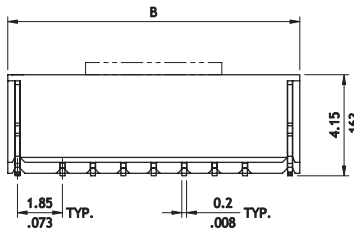

**Ordering Code**

① ② ③ ④ ⑤ ⑥ ⑦  
**CI40 15 M 1 V RA - NH**

- ① Series No.
- ② No. of Circuits: 02 ~15
- ③ Contact Type : M = SMT
- ④ Plating Code : 1 = Matte Tin over Nickel

- ⑤ Tail Style: H=Side entry  
 V=Vertical
- ⑥ Option :  
 R0=Tape & Reel Packing
- ⑦ NH = For Lead Free IR Process and Halogen-Free

**CI40 Series 1.25mm(.049") Wire to Board Housing & Terminal**

- ⊙ Locking latch provide secure mating
- ⊙ Insulation: Nylon66 UL 94V-0,Color Nature
- ⊙ Terminal : Tin plate phosphor Bronze

RoHS Compliant

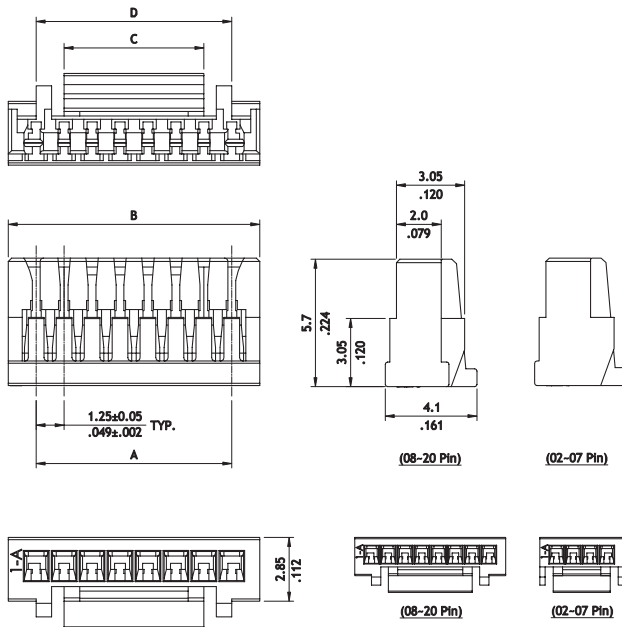
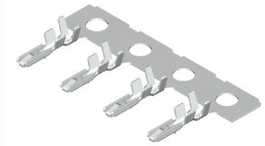
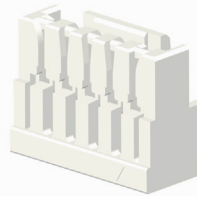

Circuits	Dimension			
	A	B	C	D
2	1.25(.049)	3.75(.148)	2.00(.079)	-
3	2.50(.098)	5.00(.197)	3.20(.126)	-
4	3.75(.148)	6.25(.246)	4.25(.167)	-
5	5.00(.197)	7.50(.295)	4.25(.167)	-
6	6.25(.246)	8.75(.344)	6.25(.246)	-
7	7.50(.295)	10.00(.394)	6.25(.246)	-
8	8.75(.344)	11.25(.443)	6.25(.246)	8.75(.344)
9	10.00(.394)	12.50(.492)	6.25(.246)	10.00(.394)
10	11.25(.443)	13.75(.541)	8.20(.323)	11.25(.443)
11	12.50(.492)	15.00(.591)	8.20(.323)	12.50(.492)
12	13.75(.541)	16.25(.640)	8.20(.323)	13.75(.541)
13	15.00(.591)	17.50(.689)	8.20(.323)	15.00(.591)
14	16.25(.640)	18.75(.738)	8.20(.323)	13.75(.541)
15	17.50(.689)	20.00(.787)	8.20(.323)	15.00(.591)
18	21.25(.837)	23.75(.935)	8.20(.323)	10.70(.421)
20	23.75(.935)	26.25(1.033)	8.20(.323)	10.70(.421)

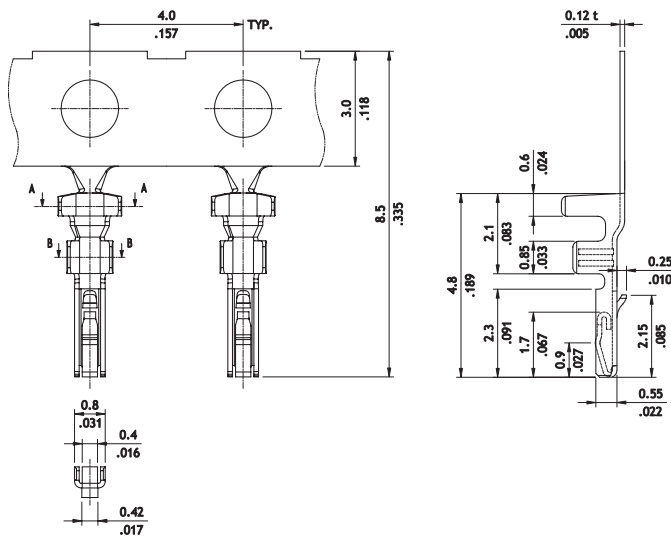

Wire Range	Insulation Diameter	Reel Qty
AWG #28-#30	1.0 (.039) MAX.	15,000 PCS.

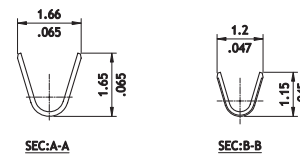

**Ordering Code**

① CI40 ② 02 ③ S ④ L000 ⑤ -NH      ① CI40 ② T01 ③ 1 ④ P ⑤ P0

- ① Series No.
- ② No. of Circuits:
- ③ S =Connector Housing
- ④ Other Options: L000 = Color Nature (Standard)
- ⑤ NH = For Lead Free and Halogen-Free

- ① Series No.
- ② Type: T01=AWG #26~ #30
- ③ Plating Code : 1=Tin over Nickel
- ④ Material : P=Phosphor Bronze
- ⑤ Other Options : P0 =Standard

**CI42 Series 1.25mm(.049") Wire to Board Housing & Terminal**

- ⊙ Mate with CI42 Header
- ⊙ Can be used with CI42 Crimp clip terminal
- ⊙ Insulation: Nylon 66 UL 94V-0, Color Nature

RoHS Compliant 

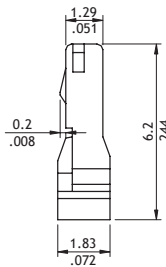
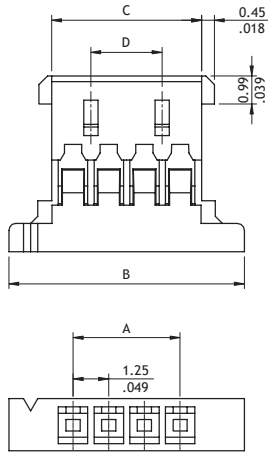
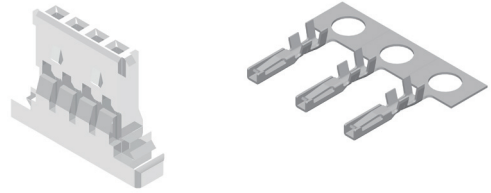

A= 1.25 \*N o. of Space  
 B=A+ 4.5  
 C= A+ 1.5  
 D= A- 1.25

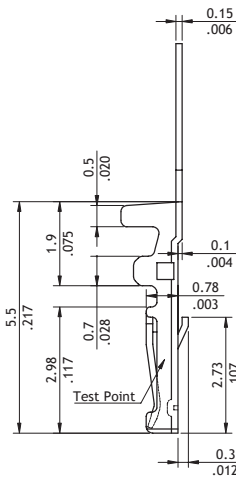
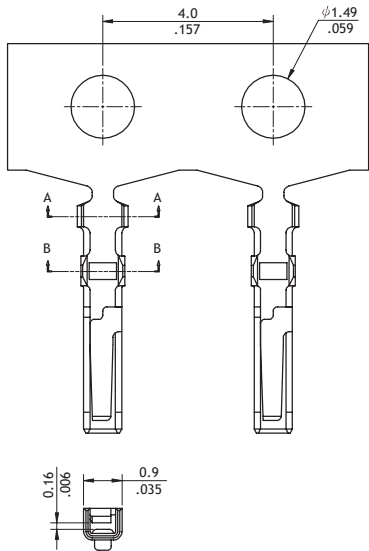
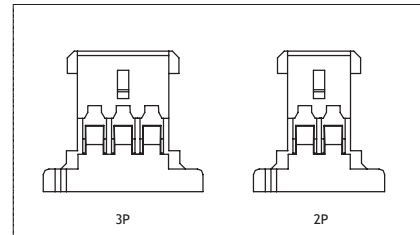

Wire Range	Insulation Diameter	Reel Qty
AWG #28-#32	0.90 (.035) MAX.	15,000 PCS

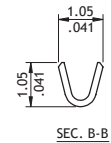
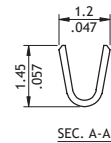

**Ordering Code**

① C I 42 ② 10 ③ S ④ L ⑤ 000

- ① Series No.
- ② No. of Circuits: 02 ~ 12
- ③ S= Housing
- ④ L=With Latch
- ⑤ Other Options: 000=Standard

① C I 42 ② T01 ③ 1 ④ P ⑤ P0

- ① Series No.
- ② Type: T01=AWG #28~ #32
- ③ Plating Code: 1 = Tin over Nickel
- ④ Material : P=Phosphor Bronze
- ⑤ Other Options : P0 =Standard

### CI42 Series 1.25mm(.049") Wire to Board SMT Header

- ⊙ Locking ramps provide secure mating
- ⊙ Fixed tab PCB hold-down for SMT tail
- ⊙ Insulator: High temperature plastic UL 94V-0, Color Nature
- ⊙ With Gold flash SMT type contact

RoHS Compliant

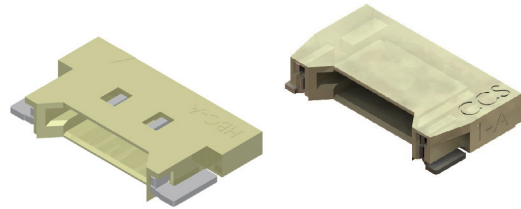

**Top mount**

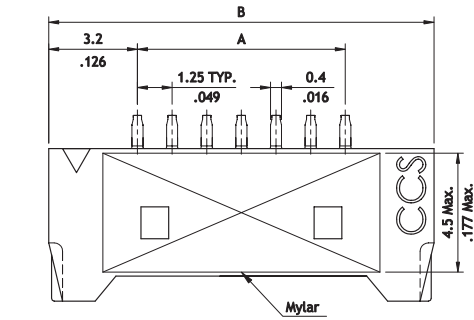

A = 1.25 x No. of Spaces  
 B = A + 6.4  
 C = A + 2.55

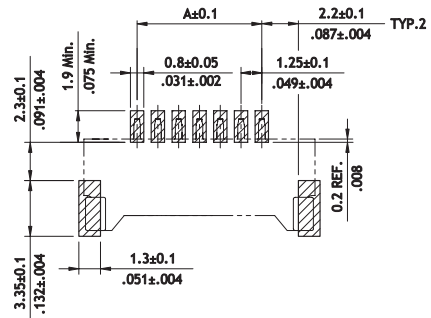

Recommended PCB Layout

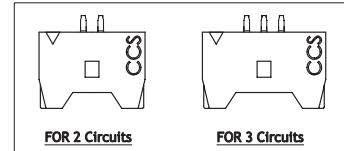
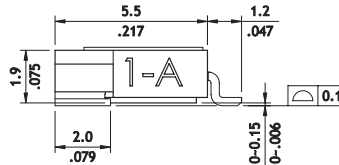
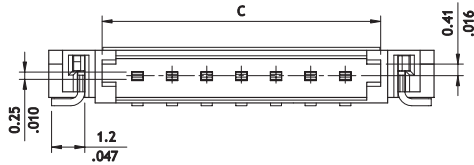

**Middle mount**

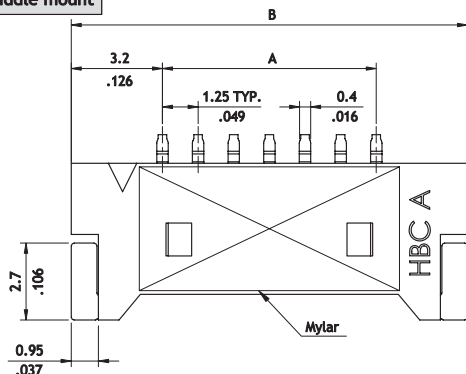

A = 1.25 x No. of Spaces  
 B = A + 6.4  
 C = A + 1.55

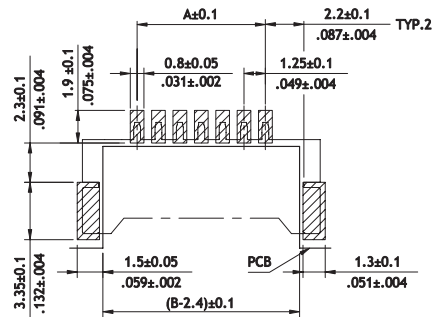

Recommended PCB Layout

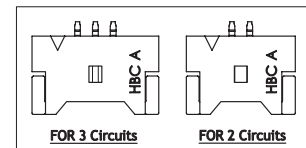
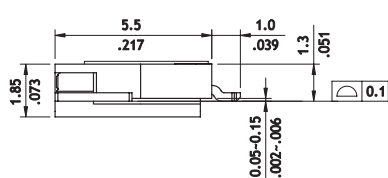
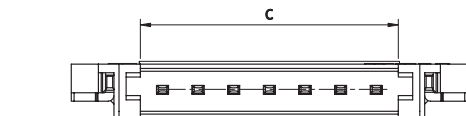

**Ordering Code**

① C I 4 2    ② 1 2    ③ M    ④ 2    ⑤ H    ⑥ R    ⑦ P    ⑧ - N H

- ① Series No.
- ② No. of Circuits: 02 ~ 12
- ③ M = SMT Type
- ④ Plating Code:  
2 = Gold flash over Nickel
- ⑤ Type: H = Side Entry
- ⑥ Packing Options:  
R = Tape & Reel
- ⑦ Other Options:  
0 = Top mount type without Mylar  
P = Top mount type with Mylar  
D = Middle mount type, Without Mylar  
A = Middle mount type, With Mylar
- ⑧ NH = For Lead Free IR process and Halogen-Free

**CI43 Series 1.25mm(.049") Wire to Board Housing & Terminal & SMT Header**

- ⊙ 2.03mm above the board
- ⊙ Copper alloy dual contacts
- ⊙ Insulation: High temperature plastic UL 94V-0, Color Black
- ⊙ With metal fixed tabs to secure connector in place

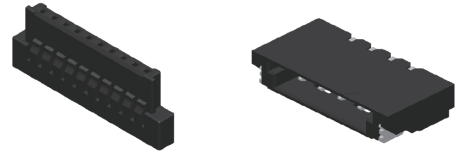

**RoHS** Compliant

CI

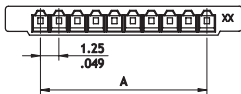
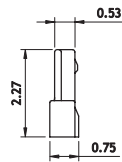
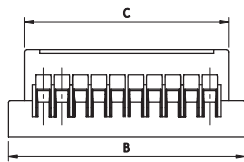

A = 1.25 \* No. of Spaces  
 B = A + 4.75  
 C = A + 2.55  
 D = A - 1.25

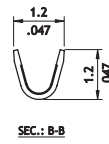
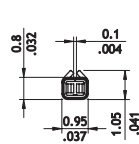
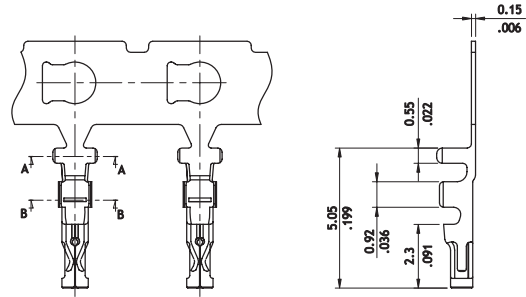
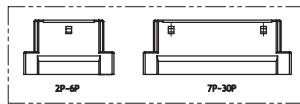

Wire Range	Insulation Diameter	Reel Qty
AWG #28-#32	1.0 MAX. (.039)	20,000 PCS.

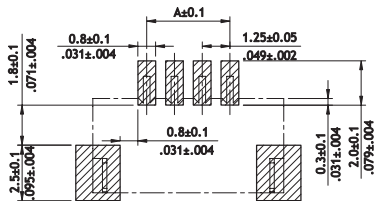
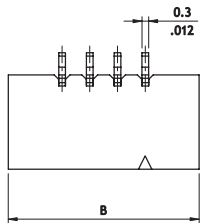

Sold Pad Pattern

A = 1.25 \* No. of Spaces  
 B = A + 4.85  
 C = A + 1.95

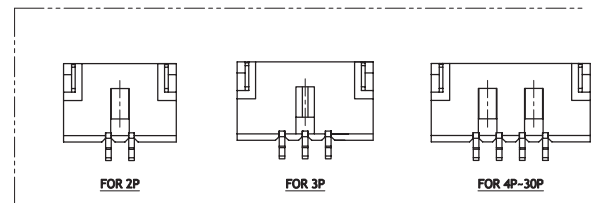
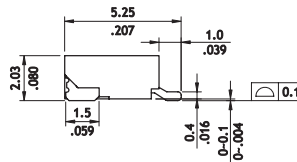
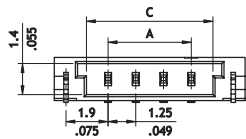

**Ordering Code**

① CI43 ② 12 ③ S ④ 0000

- ① Series No.
- ② No. of Circuits: 02 ~15,20,25,30
- ③ S = Housing
- ④ Other Options:  
0000 = Standard

① CI43 ② 12 ③ M ④ 1 ⑤ H ⑥ R ⑦ 0 ⑧ NH

- ① Series No.
- ② No. of Circuits: 02 ~30  
(Available: 02 ~12,16,24)
- ③ M = SMT Type
- ④ 1 = Matte Tin over Nickel  
2 = Gold flash over Nickel

- ⑤ Type: H=Side Entry
- ⑥ Packing Options:  
R = Tape & Reel
- ⑦ Other Options:  
0 = Standard
- ⑧ NH = For Lead Free soldering process and Halogen-Free

WIRE TO BOARD

**CI44 Series 1.25mm(.049") Wire to Board Connectors Housing & Terminal**

- ⊙ Latch housing secure terminal in housing and provides extra terminal retention
- ⊙ Terminal accommodated AWG #28 ~ #32
- ⊙ Insulator: Nylon 66 UL 94V-0, Color Nature
- ⊙ Terminal: Tin plated, Phosphor Bronze
- ⊙ Mate with CI44 header

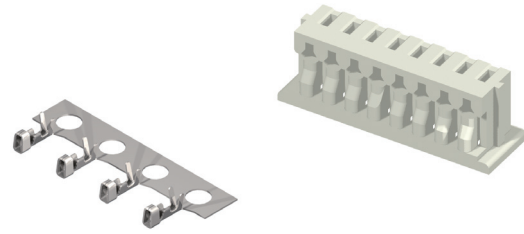

RoHS Compliant

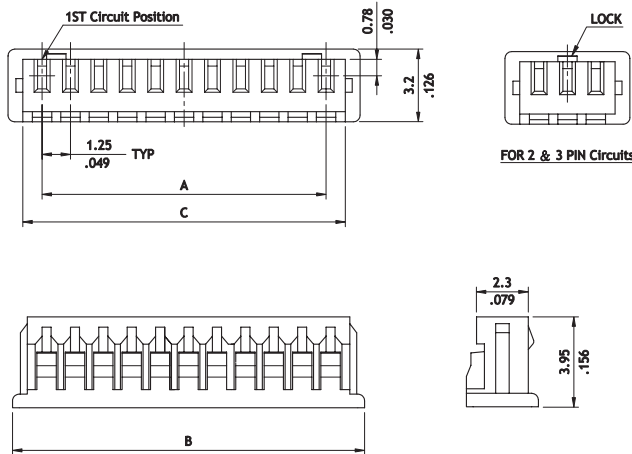

Circuits	Dimension		
	A	B	C
2	1.25(.049)	4.25(.167)	2.95(.116)
3	2.50(.098)	5.5(.217)	4.20(.165)
4	3.75(.148)	6.75(.266)	5.45(.215)
5	5.00(.197)	8.0(.315)	6.70(.264)
6	6.25(.246)	9.25(.364)	7.95(.313)
7	7.50(.295)	10.5(.413)	9.20(.362)
8	8.75(.344)	11.75(.463)	10.45(.411)
9	10.00(.394)	13.0(.512)	11.70(.461)
10	11.25(.443)	14.25(.561)	12.95(.510)
11	12.50(.492)	15.5(.610)	14.20(.559)
12	13.75(.541)	16.75(.659)	15.45(.608)
13	15.00(.591)	18.0(.709)	16.70(.657)
14	16.25(.640)	19.25(.758)	17.95(.707)
15	17.50(.689)	20.5(.807)	19.20(.756)
16	18.75(.719)	21.75(.856)	20.45(.805)

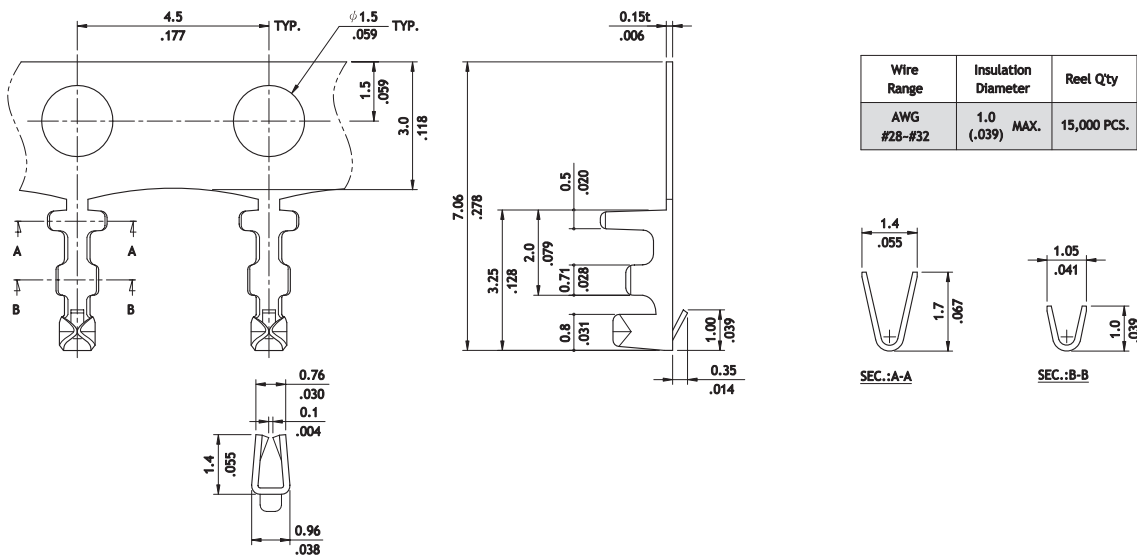

**Ordering Code**

①	②	③	④	⑤	⑥	①	②	③	④	⑤			
C	I	44	15	S00	00	NH	C	I	44	T01	1	P	P0

- ① Series No.
- ② No. of Circuits: 02 ~ 16
- ③ S00= Housing
- ④ Color: 0 = Color Nature
- ⑤ Other Options: 0 = Standard
- ⑥ NH = For Lead Free and Halogen-Free

- ① Series No.
- ② Type: T01 = AWG #28 ~ #32
- ③ Plating Code: 1 = Tin over Nickel
- ④ Material: P = Phosphor Bronze
- ⑤ Other Options: P0 = Standard

**CI44 Series 1.25mm(.049") Wire to Board Connectors DIP Headers**

- ⊙ Polarization and Low-profile
- ⊙ Locking slots provide secure mating
- ⊙ Mate with CI44 housing
- ⊙ Insulator: High temperature plastic UL 94V-0, Color Nature
- ⊙ With Tin plated DIP type contact

RoHS Compliant 

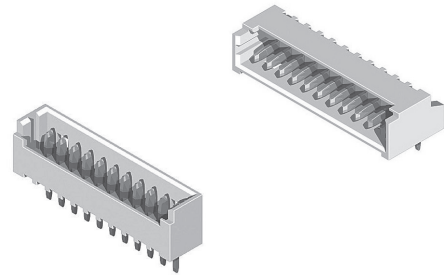

Top entry

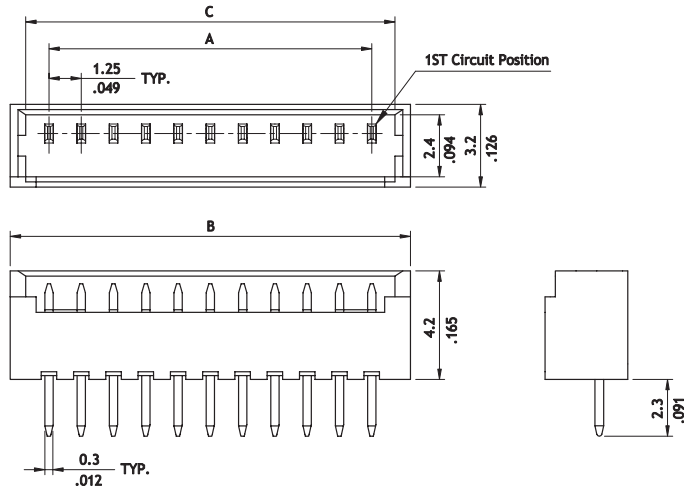

Circuits	Dimension		
	A	B	C
2	1.25(.049)	4.35(.171)	3.15(.124)
3	2.5(.098)	5.6(.220)	4.4(.173)
4	3.75(.148)	6.85(.270)	5.65(.222)
5	5.0(.197)	8.1(.319)	6.9(.272)
6	6.25(.246)	9.35(.368)	8.15(.321)
7	7.5(.295)	10.6(.417)	9.4(.370)
8	8.75(.344)	11.85(.467)	10.65(.419)
9	10.0(.394)	13.1(.516)	11.9(.469)
10	11.25(.443)	14.35(.565)	13.15(.518)
11	12.5(.492)	15.6(.614)	14.4(.567)
12	13.75(.541)	16.85(.663)	15.65(.616)
13	15.0(.591)	18.1(.713)	16.9(.665)
14	16.25(.640)	19.35(.762)	18.15(.715)
15	17.5(.689)	20.6(.811)	19.4(.764)

Side entry

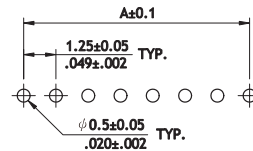
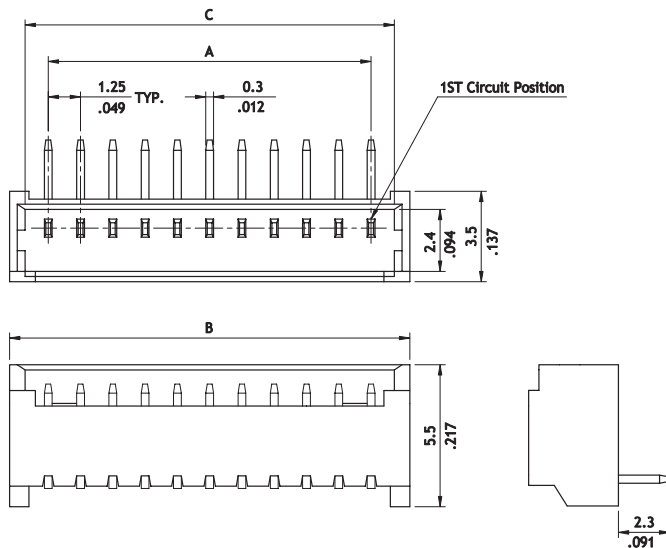

Recommended P.C. Board Layout

Ordering Code

① ② ③ ④ ⑤ ⑥ ⑦  
**CI44 15 P 1 V 00 - NH**

- ① Series No.
- ② No. of Circuits: 02 ~ 15
- ③ P = DIP Type
- ④ Plating Code : 1 = Matte Tin over Nickel
- ⑤ Type: V = Top Entry  
H = Side Entry
- ⑥ Other Options:  
00 = Standard (Tube packing)
- ⑦ NH = For Lead Free soldering process and Halogen-Free  
\*Special options consult manufacturer

**C144 Series 1.25mm(.049") Wire to Board Connectors SMT Headers**

- ⊙ Polarization and Low-profile
- ⊙ Locking slots provide secure mating
- ⊙ Fixed tabs provide PCB hold-down and strain-relief for SMT
- ⊙ Insulator: High temperature plastic UL 94V-0 , Color Nature
- ⊙ With Tin plated SMT type contact
- ⊙ Mate with C144 housing

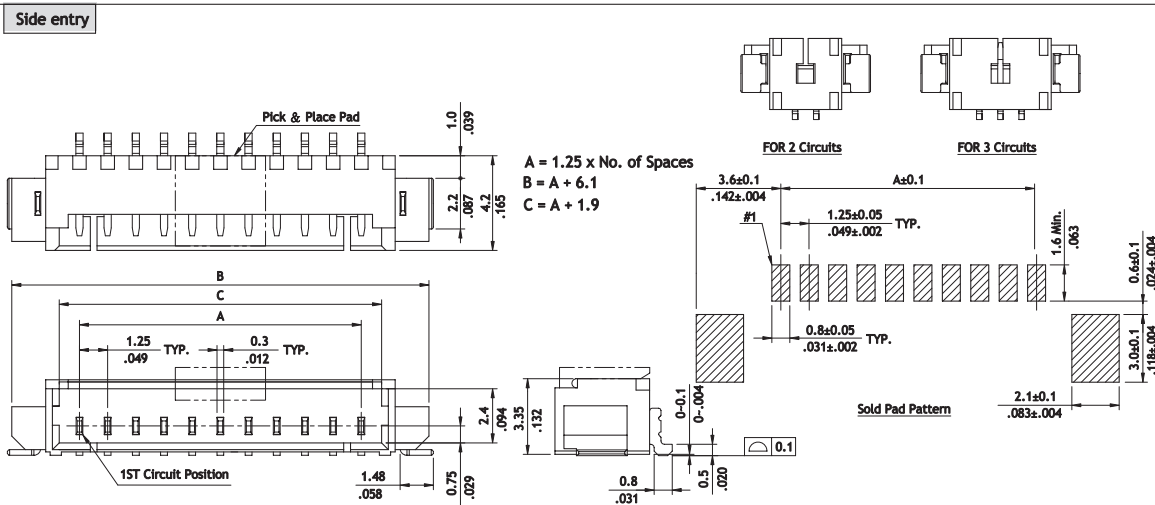
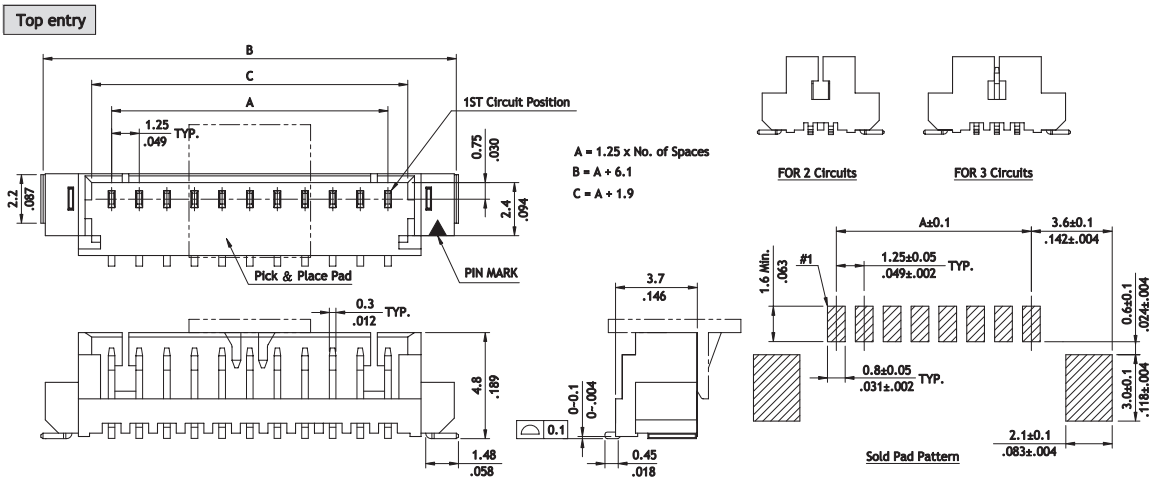
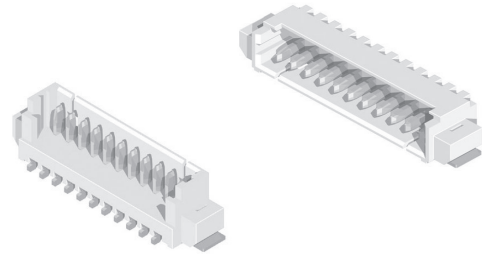

**Ordering Code**

① ② ③ ④ ⑤ ⑥ ⑦  
**C144 15 M 1 V R0 - NH**

- ① Series No.
- ② No. of Circuits: 02 ~ 15
- ③ M=SMT Type
- ④ Plating Code:  
1 = Matte Tin over Nickel
- ⑤ Type: V = Top Entry  
H = Side Entry
- ⑥ Other Options :  
00 = Standard (Tube packing)  
R0 = Tape & Reel (Without Pick & Place Pad)  
RP = Tape & Reel (With Pick & Place Pad)
- ⑦ NH = For Lead Free soldering process and Halogen-Free  
\* Special option consult manufacturer

**CI45 Series 1.25mm(.049") Wire to Board Housing & SMT Headers**

- ⊙ With locking latch provide secure mating
- ⊙ Mate with CI45 Header
- ⊙ Mate with CI14 crimp clip terminal (P/N: CI14T011PE0)

RoHS Compliant

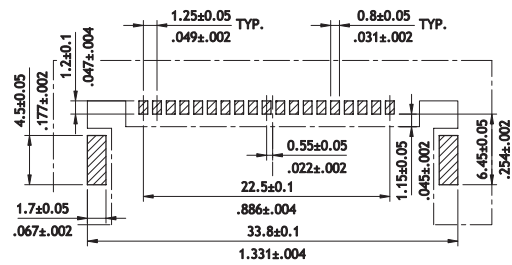
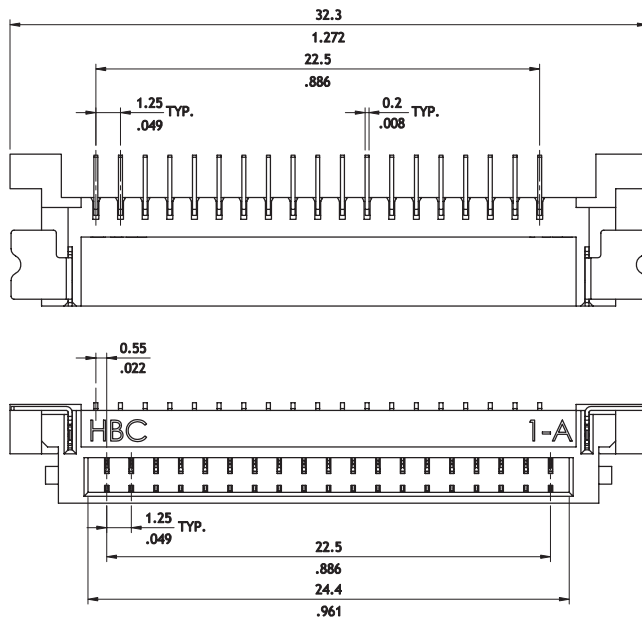
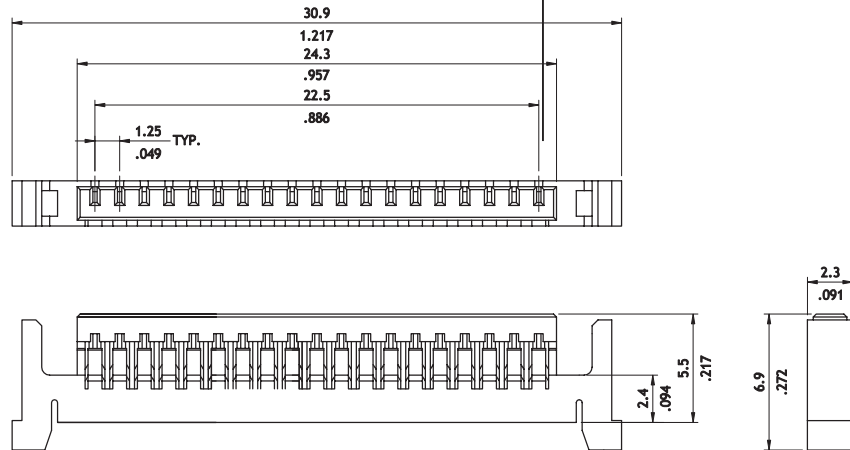
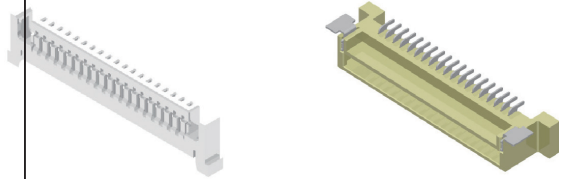

Recommended P.C. Board Layout

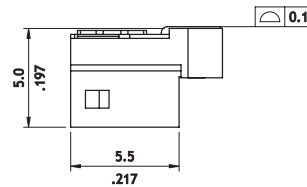

**Ordering Code**

①	②	③	④	⑤	⑥	①	②	③	④	⑤	⑥	⑦
CI45	19	S	L	0000	-NH	CI45	19	M	1	H	R0	-NH

- ① Series No.
- ② No. of Circuits: 19
- ③ S = Housing
- ④ L = With Locking Latch
- ⑤ Other Option: 000=Standard
- ⑥ NH = For Lead Free IR Process and Halogen-Free

- ① Series No.
- ② No. of Circuits: 19
- ③ M = SMT Type
- ④ Plating Code: 1 = Matte Tin over Nickel
- ⑤ Type: H=Side Entry
- ⑥ Packing Options: R0 = Tape & Reel
- ⑦ NH = For Lead Free IR Process and Halogen-Free

**CI46 Series 1.25mm(.049") Wire to Board Connectors Housing & Terminal**

- ⊙ With locking latch provide secure mating
- ⊙ Mate with CI46 Header
- ⊙ Can be used with CI46 Crimp Clip Terminal
- ⊙ Insulator: Nylon 66 UL 94V-0, Color Nature

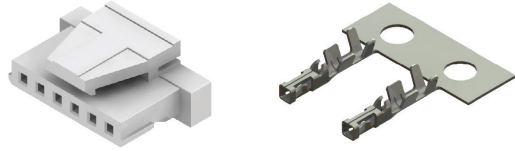

RoHS Compliant

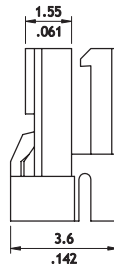
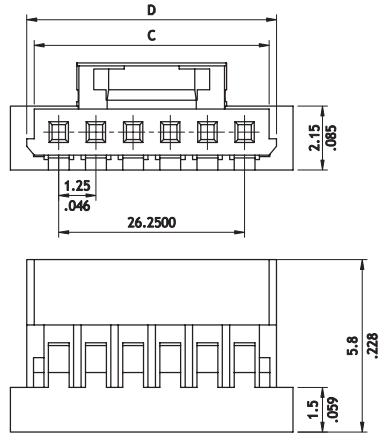

A = 1.25 x No. of Spaces  
 B = A + 3.25  
 C = A + 1.65  
 D = A + 2.15  
 \*AVAILABLE IN 2 THROUGH 20

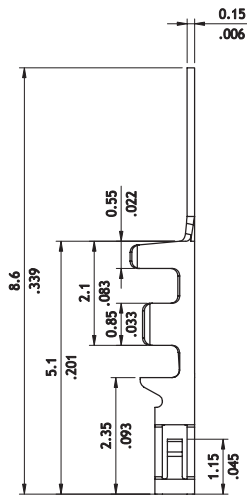
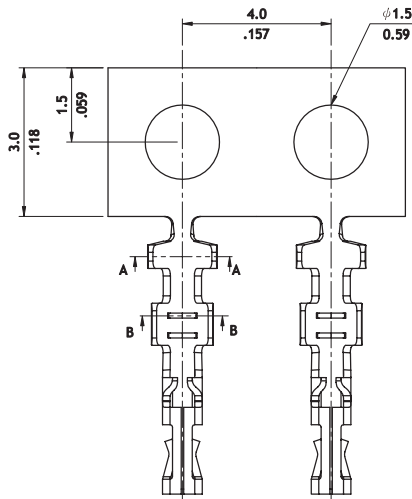

Wire Range	Insulation Diameter	Reel Qty
AWG #26-#32	0.90 (.035) MAX.	16,000 PCS

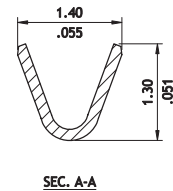
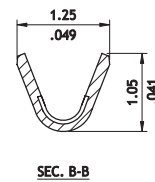

**Ordering Code**

① CI46 ② 20 ③ S ④ L ⑤ 000

- ① Series No.
- ② No. of Circuits: 02 ~ 20
- ③ S = Housing
- ④ L = With Locking Latch
- ⑤ Other Options: 000 = Standard

① CI46 ② T01 ③ 1 ④ P ⑤ E0

- ① Series No.
- ② Type: T01 = AWG #26 ~ #32
- ③ Plating Code: 1 = Tin over Nickel
- ④ Material: P = Phosphor Bronze
- ⑤ Other Options: E0 = Standard

**CI46 Series 1.25mm(.049") Wire to Board Connectors SMT Headers**

- ⊙ With locks provide secure mating
- ⊙ Fixed tabs provide PCB hold-down
- ⊙ Mate with CI46 Housing
- ⊙ Insulator: High temperature plastic UL 94V-0, Color Nature

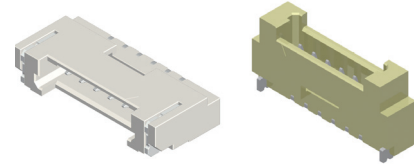

RoHS Compliant

CI

P/N CI46\*\*M1HR0-NH

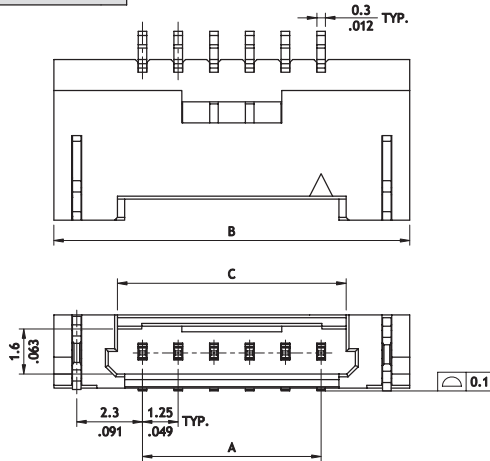

A = 1.25 x No. of Spaces  
B = A + 6.2  
C = A + 1.75

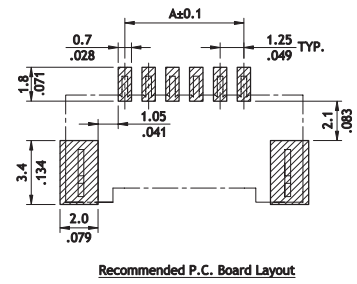

P/N CI46\*\*M1VR0-NH

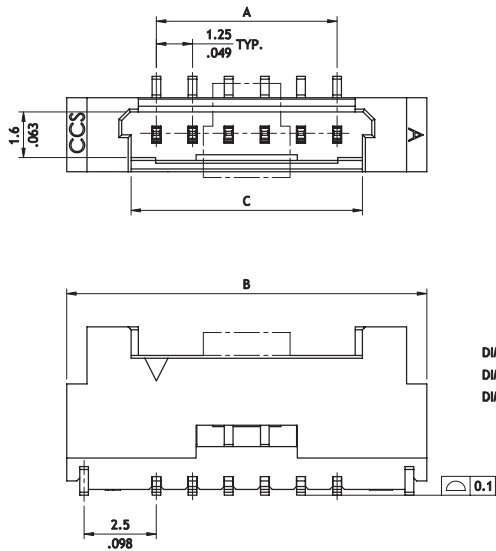

DIM. A = 1.25 x No. of Spaces  
DIM. B = DIM. A + 6.2  
DIM. C = DIM. A + 1.75

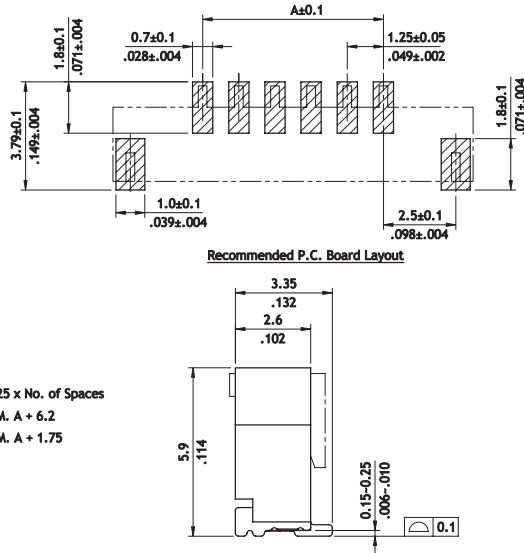

**Ordering Code**

① ② ③ ④ ⑤ ⑥ ⑦ ⑧  
**CI46 20 M 1 V R 0 - NH**

- ① Series No.
- ② No. of Circuits: 02 ~ 20
- ③ M = SMT Type
- ④ Plating Code : 1= Matte Tin over Nickel
- ⑤ Type : V =Top Entry ; H=Side Entry

- ⑥ Packing Options: R0 = Tape & Reel
- ⑦ Other Options: 0 = Standard
- ⑧ NH = For Lead Free soldering process and Halogen-Free

WIRE TO BOARD

**CIDL Series 1.25mm(.049") Wire to Board Housing and SMT Header Connectors**

- ⊙ Insulator: Nylon 66 UL 94V-0, Color Nature
- ⊙ Insulator: High temperature UL 94V-0 , Color Nature
- ⊙ Mate with C114 Crimp clip terminal (P/N : C114T011PE0)

RoHS Compliant

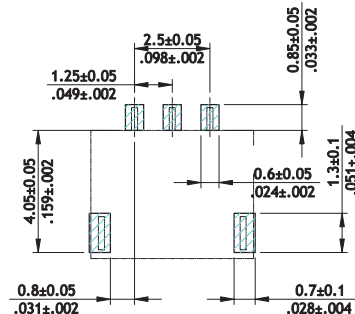
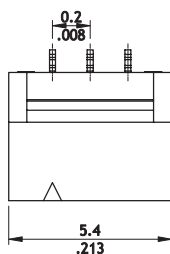
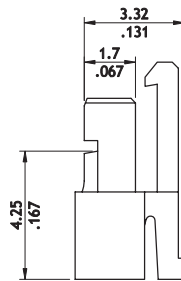
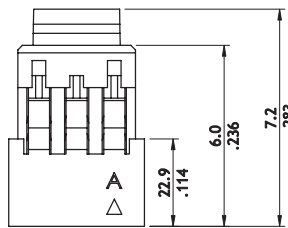
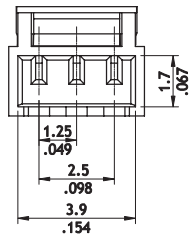
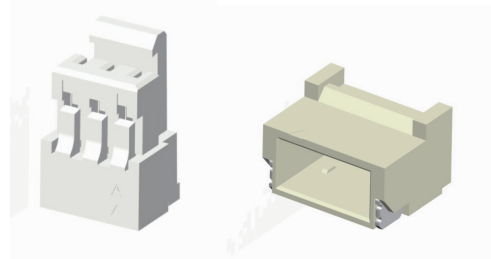

P.C. Board Layout

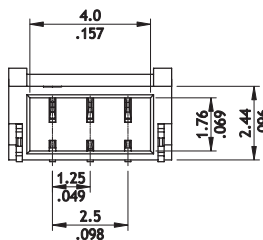
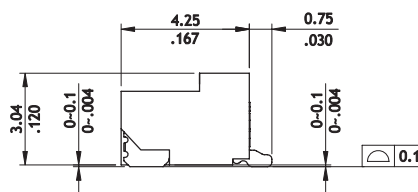

**Ordering Code**

① CIDL ② 03 ③ S ④ L000 - ⑤ NH

① CIDL ② 03 ③ M ④ 1 ⑤ H ⑥ R0 - ⑦ NH

- ① Series No.
- ② No. of Circuits: 03
- ③ S = Connector Housing
- ④ Other option: L000=With Locking Latch
- ⑤ Other Option: -NH= Halogen-Free

- ① Series No.
- ② No. of Circuits: 03
- ③ M=SMT type Header
- ④ Plating: 1= Matte Tin over Nickel
- ⑤ Type: H = Side Entry Type
- ⑥ Option : R0 = Tape & Reel Packing
- ⑦ NH= For Lead Free IR Processes and Halogen-Free

**CI15 Series 1.50mm(.059") Wire to Board Connectors Housing & Terminal**

- ⊙ Terminal accommodated AWG #26 ~ #32
- ⊙ Insulator: Nylon 66 UL 94V-0, Color Nature
- ⊙ Terminal: Tin plated, Phosphor Bronze
- ⊙ Mate with CI15 Header

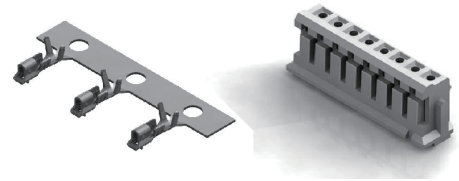

RoHS Compliant

CI

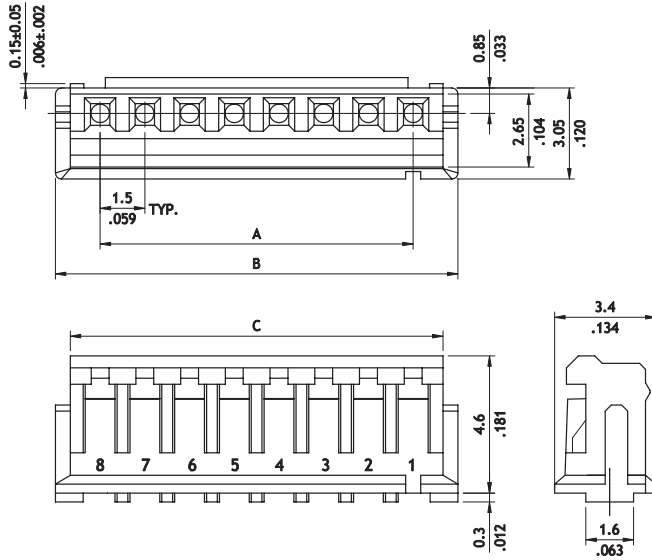

Circuits	Dimension		
	A	B	C
2	1.5(.059)	4.5(.177)	3.5(.138)
3	3.0(.118)	6.0(.236)	5.0(.197)
4	4.5(.177)	7.5(.295)	6.5(.256)
5	6.0(.236)	9.0(.354)	8.0(.315)
6	7.5(.295)	10.5(.413)	9.5(.374)
7	9.0(.354)	12.0(.472)	11.0(.433)
8	10.5(.413)	13.5(.513)	12.5(.492)
9	12.0(.472)	15.0(.591)	14.0(.551)
10	13.5(.531)	16.5(.650)	15.5(.610)
11	15.0(.591)	18.0(.709)	17.0(.669)
12	16.5(.650)	19.5(.768)	18.5(.728)
13	18.0(.709)	21.0(.827)	20.0(.787)
14	19.5(.768)	22.5(.886)	21.5(.846)
15	21.0(.827)	24.0(.945)	23.0(.905)

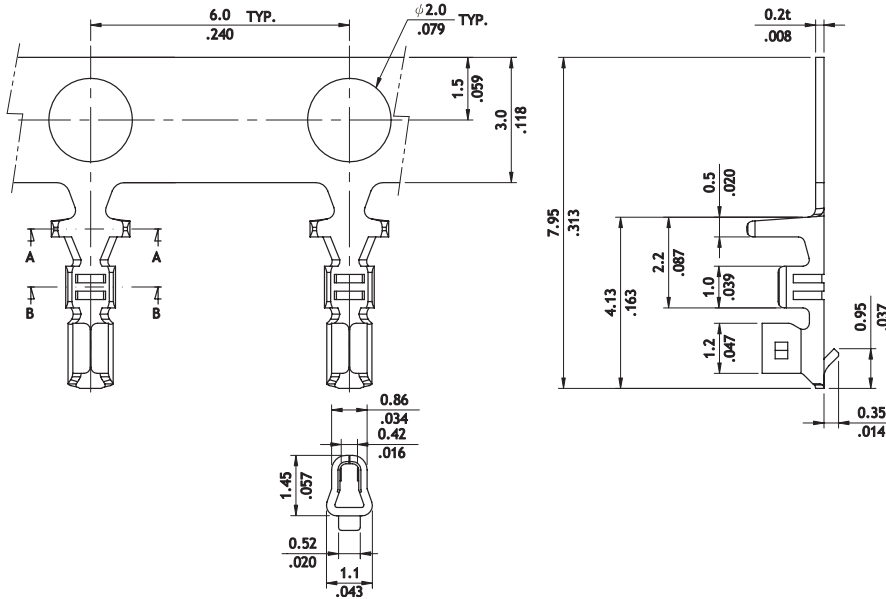

Wire Range	Insulation Diameter	Reel Qty
AWG #26-#32	1.10 (.043) MAX.	10,000 PCS

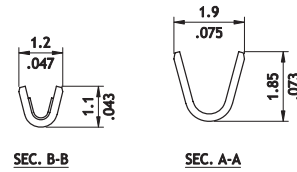

**Ordering Code**

① CI15 ② 15 ③ S ④ 0000

① CI15 ② T01 ③ 1 ④ P ⑤ E0

- ① Series No.
- ② No. of Circuits: 02 ~ 15
- ③ S = Housing
- ④ Other Options: 0000 = Standard

- ① Series No.
- ② Type: T01 = AWG #26 ~ #32
- ③ Plating Code: 1 = Tin over Nickel
- ④ Material: P = Phosphor Bronze
- ⑤ Other Options: E0 = Standard

WIRE TO BOARD

**C115 Series 1.50mm(.059") Wire to Board Connectors DIP Headers**

- ⊙ Polarization and Low-profile
- ⊙ Locking slots provide secure mating
- ⊙ Insulator: High temperature plastic UL 94V-0, Color Nature
- ⊙ With Tin plated DIP type contact
- ⊙ Mate with C115 Housing

RoHS Compliant

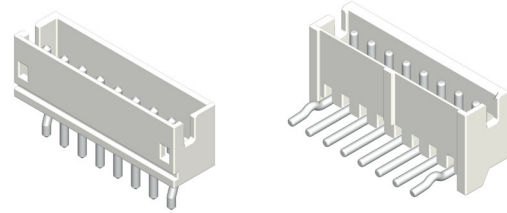

Top entry

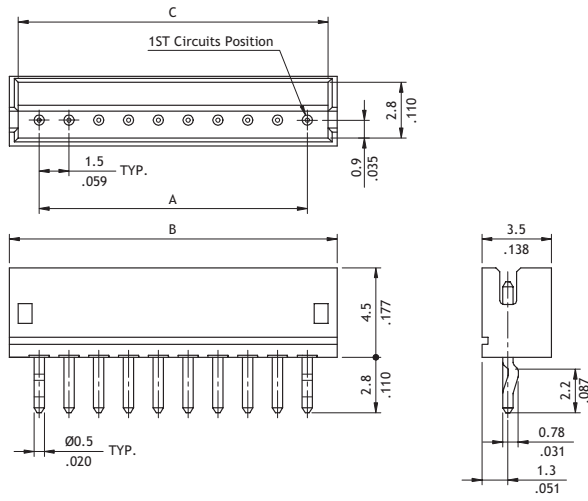

Circuits	Dimension		
	A	B	C
2	1.5(.059)	4.5(.177)	3.6(.142)
3	3.0(.118)	6.0(.236)	5.1(.201)
4	4.5(.177)	7.5(.295)	6.6(.260)
5	6.0(.236)	9.0(.354)	8.1(.319)
6	7.5(.295)	10.5(.413)	9.6(.378)
7	9.0(.354)	12.0(.472)	11.1(.437)
8	10.5(.413)	13.5(.531)	12.6(.496)
9	12.0(.472)	15.0(.591)	14.1(.555)
10	13.5(.531)	16.5(.650)	15.6(.614)
11	15.0(.591)	18.0(.709)	17.1(.673)
12	16.5(.650)	19.5(.768)	18.6(.732)
13	18.0(.709)	21.0(.827)	20.1(.791)
14	19.5(.768)	22.5(.886)	21.6(.850)
15	21.0(.827)	24.0(.945)	23.1(.909)

Side entry

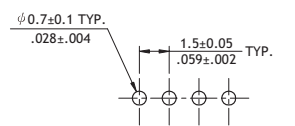
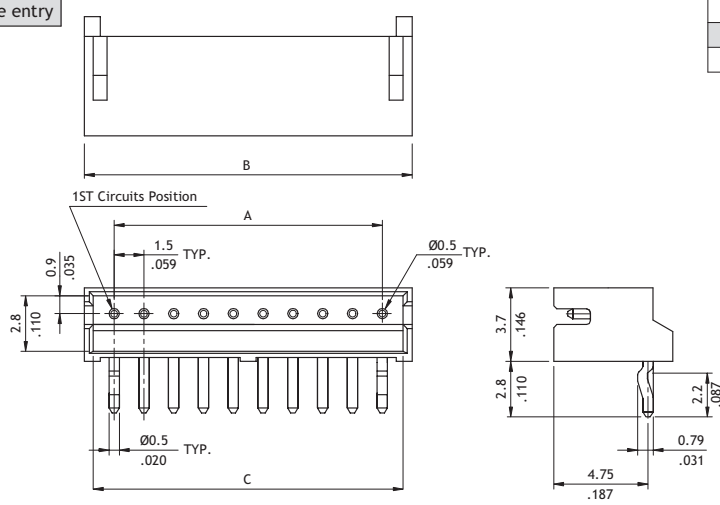

Recommended P.C. Board Layout

**Ordering Code**

① ② ③ ④ ⑤ ⑥ ⑦ ⑧  
**C115 15 P 1 V K 0 - NH**

- ① Series No.
- ② No. of Circuits: 02 ~15
- ③ P = DIP Type
- ④ Plating Code : 1= Matte Tin over Nickel
- ⑤ Type : V =Straight H=Right Angle
- ⑥ K = With Pin Kinked
- ⑦ Other Options: 0 = Standard
- ⑧ NH = For Lead Free soldering process and Halogen-Free

CI

WIRE TO BOARD

**C115 Series 1.50mm(.059") Wire to Board Connectors SMT Headers**

- ⊙ Polarization and Low-profile
- ⊙ Locking slots provide secure mating
- ⊙ Fixed tabs provide PCB hold-down and strain-relief for SMT tails
- ⊙ Insulator: High temperature plastic UL 94V-0, Color Nature
- ⊙ With Tin plated SMT type contact
- ⊙ Mate with C115 Housing

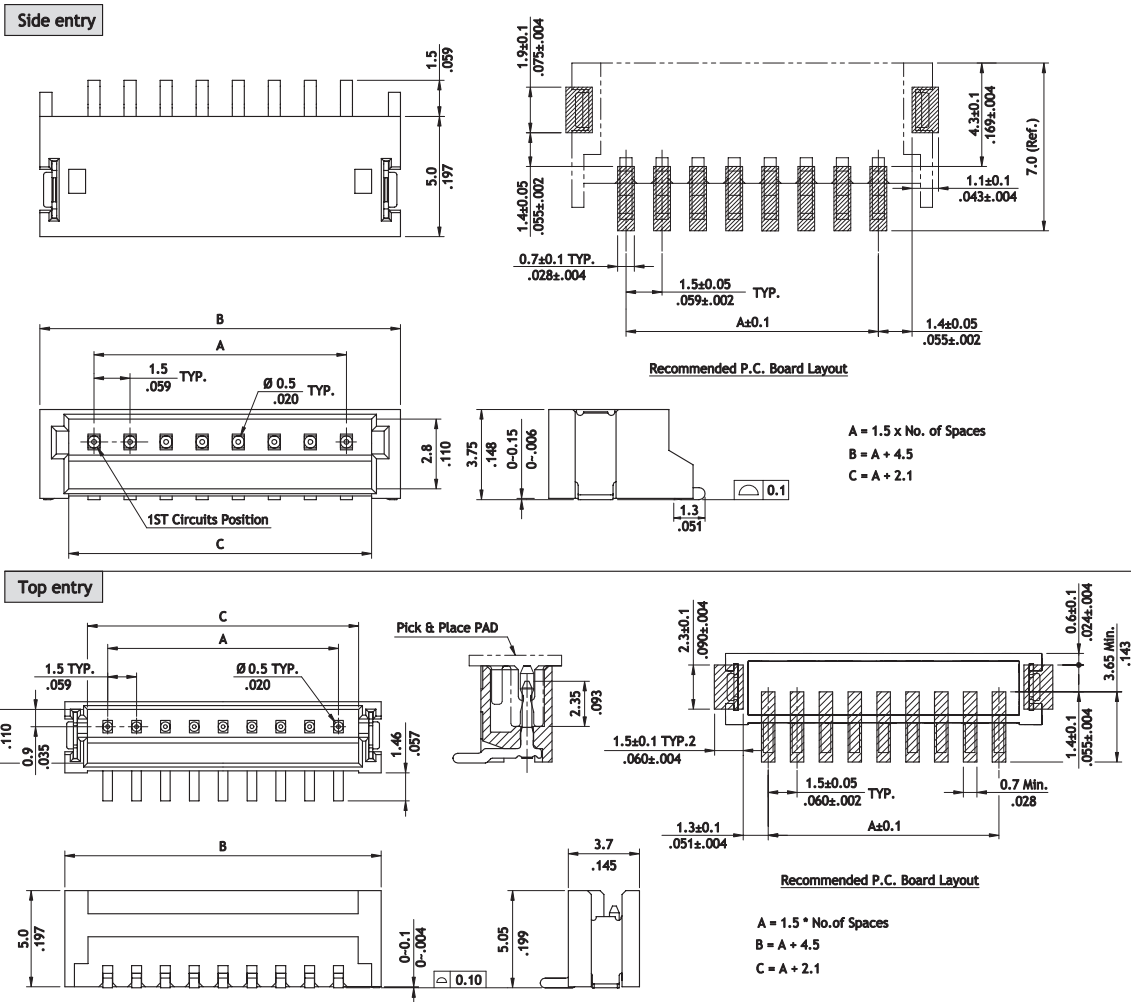
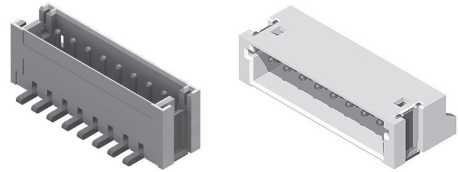

**Ordering Code**

① ② ③ ④ ⑤ ⑥ ⑦ ⑧  
**C 1 5 1 5 M 1 V R 0 - N H**

- ① Series No.
- ② No. of Circuits: 02 ~ 15
- ③ M = SMT Type
- ④ Plating Code: 1 = Matte Tin over Nickel
- ⑤ Type: V = Top Entry H= Side Entry
- ⑥ Packing Options:  
 R = Tape & Reel  
 T = Tube
- ⑦ Other Options: 0 = Standard  
 \*Special options consult manufacturer
- ⑧ NH = For Lead Free soldering process and Halogen-Free

**CI15 Series 1.50mm(.059") Wire to Board Latch Type Housing & SMT Header**

- ⊙ Fixed tabs provide PCB hold-down
- ⊙ Insulator: High temperature UL 94V-0, Color Nature
- ⊙ Housing: Nylon 66 UL 94V-0, Color Nature
- ⊙ Housing mate with CI15 Terminal (P/N: CI15T011PE0)

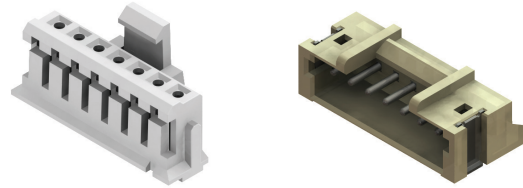

RoHS Compliant

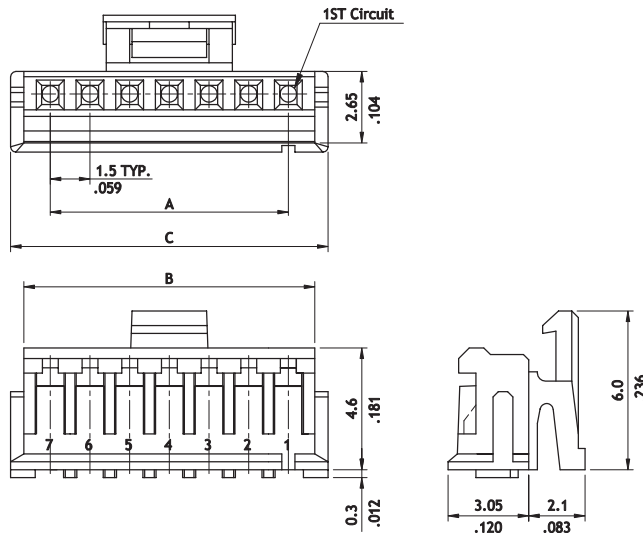

Circuits	Dimension		
	A	B	C
4	4.50(.177)	6.5(.256)	7.50(.295)
5	6.00(.236)	8.0(.315)	9.00(.354)
6	7.50(.295)	9.5(.374)	10.50(.413)
7	9.00(.354)	11.0(.433)	12.00(.472)
9	12.00(.472)	14.0(.551)	15.00(.591)
14	19.50(.767)	21.5(.846)	22.50(.886)

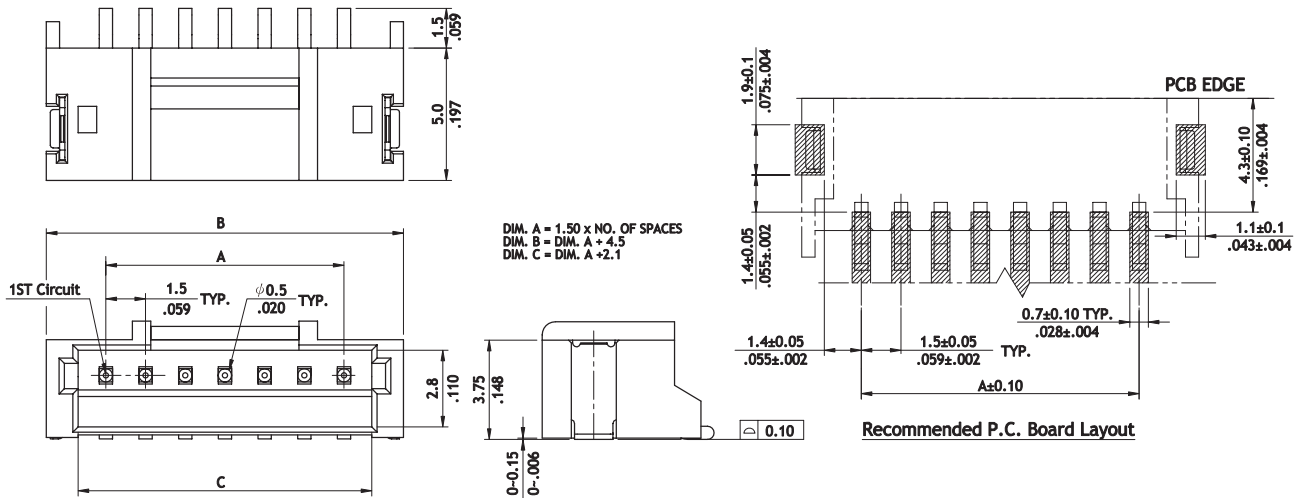

**Ordering Code**

① CI15 ② 07 ③ S ④ L000

① CI15 ② 07 ③ M ④ 1 ⑤ H ⑥ T ⑦ L ⑧ NH

- ① Series No.
- ② No. of Circuits: 04~ 07 , 09 , 14
- ③ M = SMT Type
- ④ Plating Code: 1 = Matte Tin over Nickel
- ⑤ Type: H = Right Angle
- ⑥ Packing Options: T = Tube (Standard) R = Tape & Reel
- ⑦ L = Latch Type
- ⑧ NH = For Lead Free IR Process and Halogen-Free

CI

WIRE TO BOARD

**CIFA Series 1.50mm (.059") Wire to Board Connectors Housing**

- ⊙ Insulator: Nylon 66 UL 94V-0, Color Nature
- ⊙ Mate with CIFA Header
- ⊙ Housing mate with CI15 Terminal (P/N : CI15T011PE0)

RoHS Compliant  

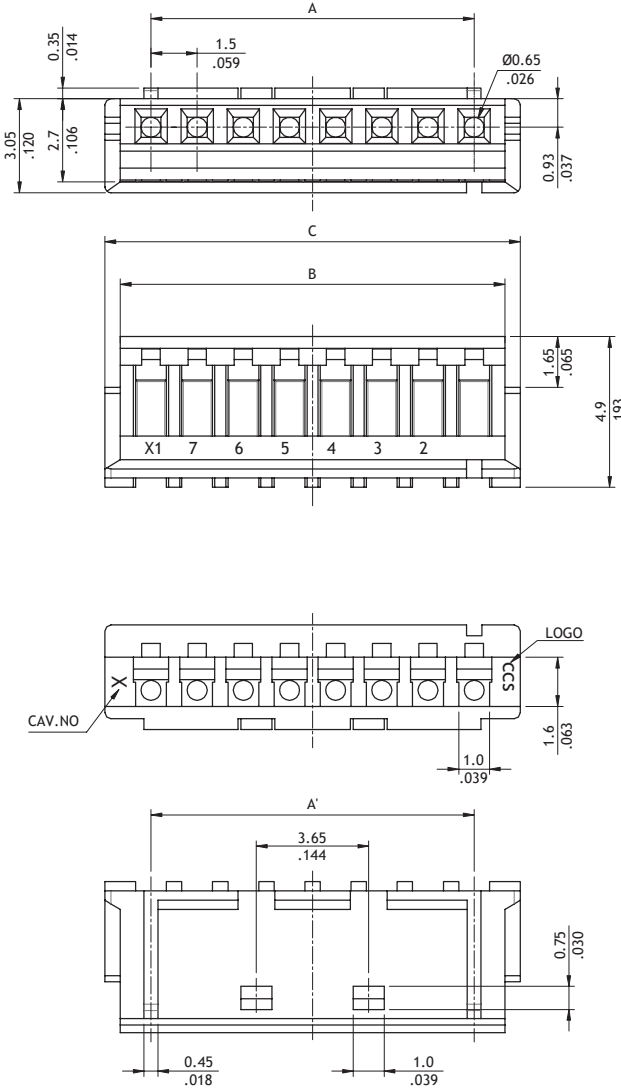
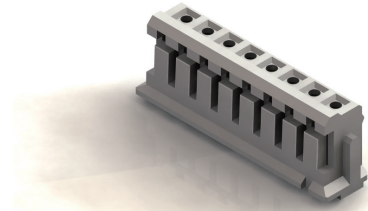

**PIN2-5 LOCK**

A= 1.5\* No of space  
 A' = A  
 B=A+ 2  
 C= A+ 3

**Ordering Code**

① ② ③ ④  
**C I F A 0 2 S 0 0 0 0**

- ① Series No.
- ② No. of Circuits: 02~15
- ③ S = Connector Housing
- ④ Color Option: 0000 = Color Nature

**CIFA Series 1.50mm (.059") Wire to Board Connectors SMT Header**

- ⊙ Insulator: Nylon 66 UL 94V-0, Color Nature
- ⊙ Mate with CIFA Header
- ⊙ Housing mate with CI15 Terminal (P/N : CI15T011PE0)

RoHS Compliant

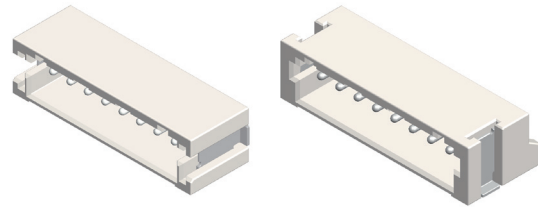

P/N CIFA\*\*M\*\*H\*\*-NH

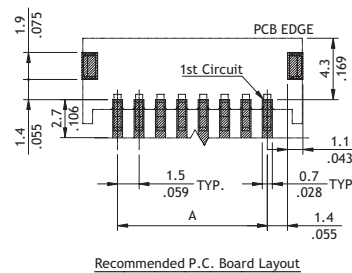
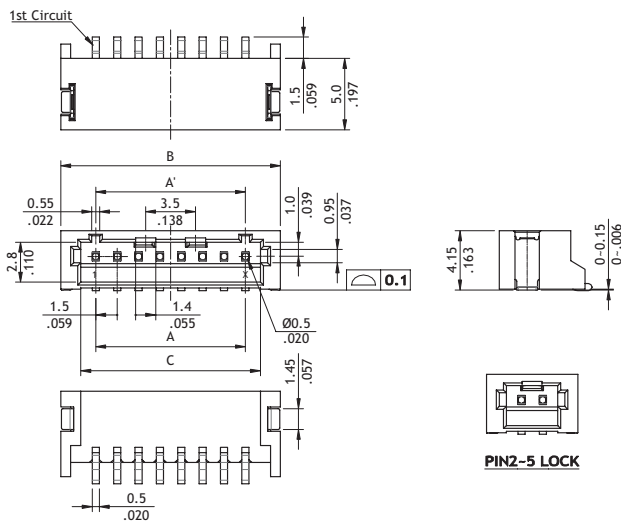

A = 1.5 \* No of space  
 A' = A  
 B = A + 4.9  
 C = A + 2.1

P/N CIFA\*\*M\*\*V\*\*-NH

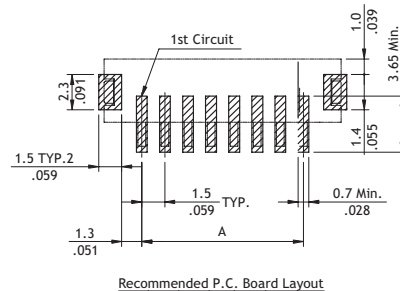
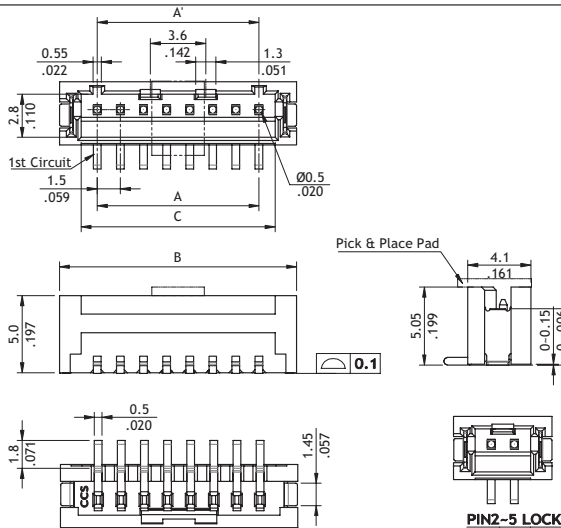

A = 1.5 \* No of space  
 A' = A  
 B = A + 4.9  
 C = A + 2.1

**Ordering Code**

① ② ③ ④ ⑤ ⑥ ⑦ ⑧  
**CIFA 15 M 1 H R 0 - NH**

- ① Series No.
- ② No. of Circuits: 02~15
- ③ M = SMT Type Header
- ④ Plating Code : 1= Matte Tin over Nickel

- ⑤ Type : V = Top Entry H= Side Entry
- ⑥ Packing option:  
 R = Tape & Reel with pad  
 T = Tube Packing without pad
- ⑦ Options : 0 = Color Nature (Standard)
- ⑧ NH = For Lead Free soldering process and Halogen-Free

**CI19 Series 1.50mm(.059") Wire to Board Connectors Housing & Terminal**

- ⊙ Mate with CI19 Header
- ⊙ Can be used with CI19 Crimp Clip Terminal
- ⊙ Insulator: High temperature plastic UL 94V-0, Color Nature

RoHS Compliant 

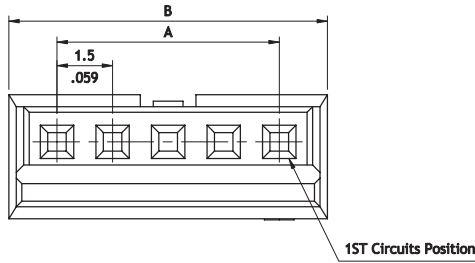
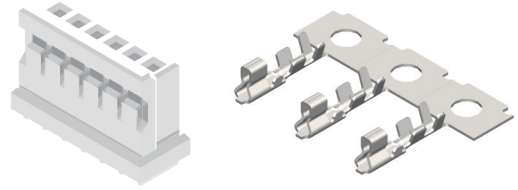

A = 1.5 \* No. of Spaces  
 B = A + 2.6  
 C = A + 2.2

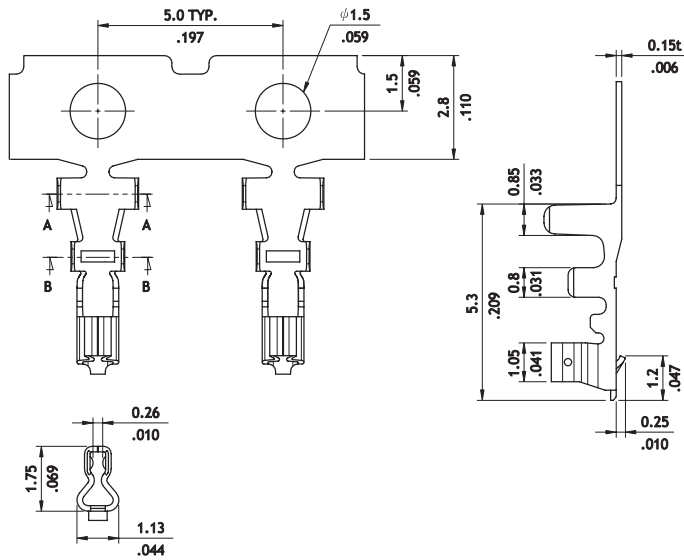
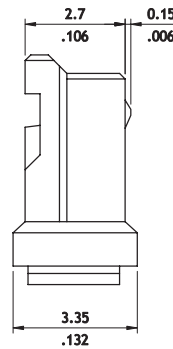
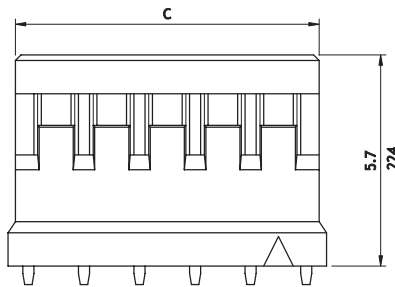

Wire Range	Insulation Diameter	Reel Qty
AWG #24-#30	1.1 (.043) MAX.	15,000 PCS.

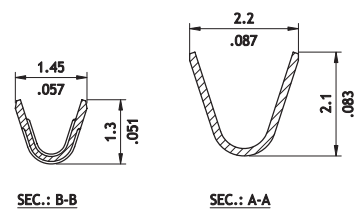

**Ordering Code**

① CI19 ② 08 ③ S ④ L ⑤ 000 - ⑥ NH

① CI19 ② T01 ③ 1 ④ P ⑤ E0

- ① Series No.
- ② No. of Circuits: 02 ~ 15 (Available: 02 ~ 06 , 08)
- ③ S = Housing
- ④ L = With Ramp
- ⑤ Other Options: 000 = Standard
- ⑥ NH = Halogen-Free

- ① Series No.
- ② Type: T01 = AWG #24 ~ #30
- ③ Plating Code: 1 = Tin over Nickel
- ④ Material: P = Phosphor Bronze
- ⑤ Other Option: E0 = Standard

**C119 Series 1.50mm(.059") Wire to Board Connectors SMT Headers**

© Insulator: High temperature plastic UL 94V-0, Color Black

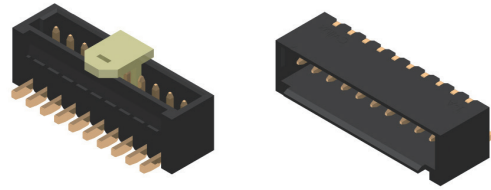

**Side entry**

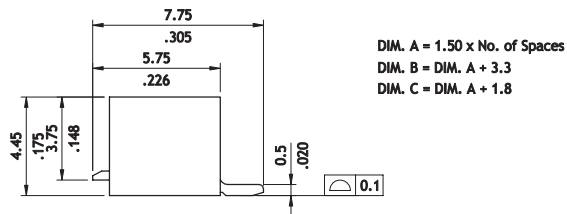
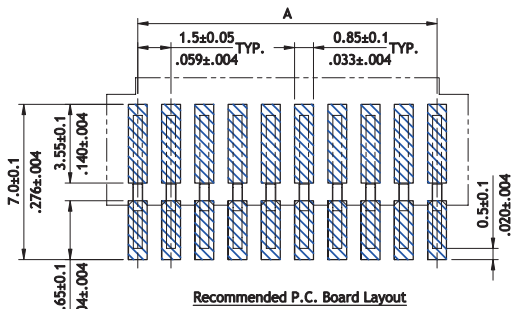
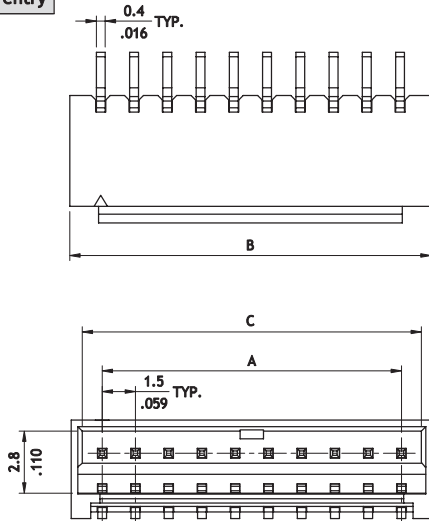

DIM. A = 1.50 x No. of Spaces  
 DIM. B = DIM. A + 3.3  
 DIM. C = DIM. A + 1.8

**Top entry**

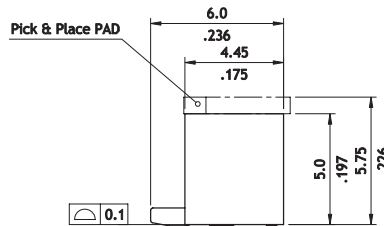
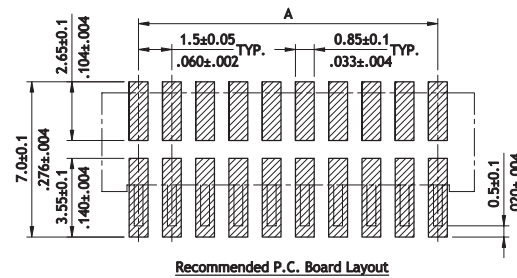
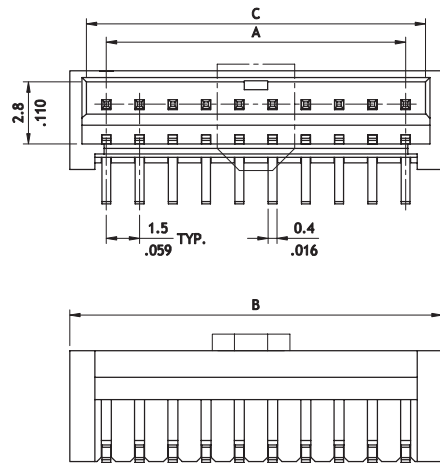

DIM. A = 1.50 x No. of Spaces  
 DIM. B = DIM. A + 3.3  
 DIM. C = DIM. A + 1.8

**Ordering Code**

①	②	③	④	⑤	⑥	⑦
C119	20	M	1	H	R0	NH

① Series No.  
 ② No. of Circuits: 02 ~ 20  
 ③ M = SMT Type  
 ④ Plating Code:  
 1 = Matte Tin over Nickel  
 2 = Gold flash over Nickel  
 ⑤ Type : V = Top Entry  
 H = Side Entry  
 ⑥ Packing Options:  
 R0 = Tape & Reel  
 ⑦ NH = For Lead Free IR Process and Halogen-Free

**CI87 Series 1.50mm(.059") Wire to Board Housing & Terminal & SMT Header**

- ⊙ Locking slots provide secure mating
- ⊙ Fixed tabs provide PCB hold-down and strain-relief for SMT tails
- ⊙ Insulator: High temperature plastic UL 94V-0, Color Black (Header)
- ⊙ Insulation: Nylon66 UL 94V-0, Color Nature (Housing)

RoHS Compliant

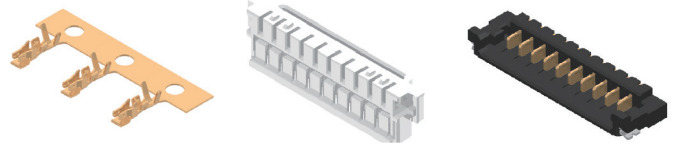

P/N CI87\*\*S0000

Circuits	Dimension		
	A	B	C
8	10.5(.413)	15.8(.622)	12.8(.503)
10	13.5(.531)	18.8(.740)	15.8(.622)

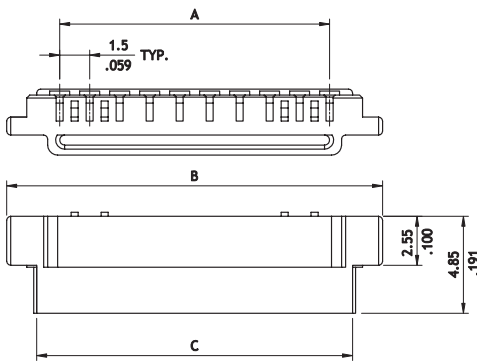

P/N CI87\*\*M2VR0-NH

Circuits	Dimension		
	A	B	C
8	10.5(.413)	16.5(.650)	12.9(.508)
10	13.5(.531)	19.5(.768)	15.9(.626)

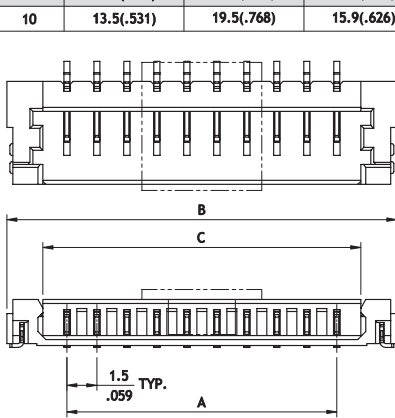

P/N CI87T012PPO

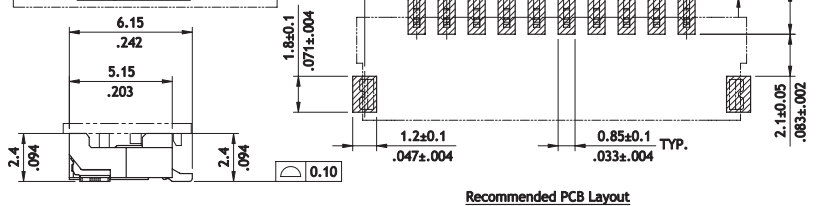
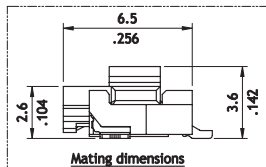
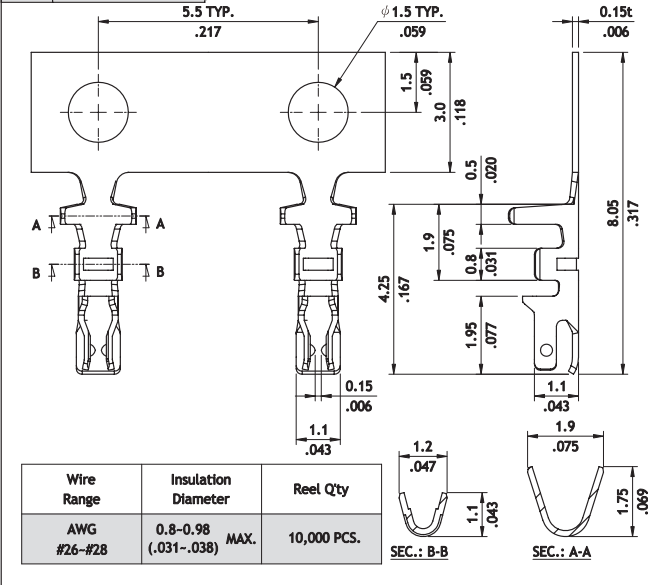

**Ordering Code**

① C I 87    ② 10    ③ S    ④ 0000

① C I 87    ② 10    ③ M    ④ 2    ⑤ V    ⑥ R    ⑦ 0    ⑧ NH

- ① Series No.
- ② No. of Circuits: 8,10
- ③ S = Housing
- ④ Other Options: 0000 = Standard

- ① Series No.
- ② No. of Circuits: 8,10
- ③ M = SMT Type
- ④ Plating Code : 2 = Gold flash over Nickel
- ⑤ Type: V = Top Entry
- ⑥ Packing Options: R = Tape & Reel
- ⑦ Other Options: 0 = Standard
- ⑧ NH = For Lead Free IR process and Halogen-Free

**CIDW Series 1.5mm(.059") Single Row Wire to Board Housing & Terminal**

- ⊙ With locking wall
- ⊙ Mate with CIDW header
- ⊙ Insulator : PA66 94V- 0 , color Nature , terminal accommdated , AWG #24~28
- ⊙ Terminal : Tin plated Phosphor Bronze

**RoHS** Compliant

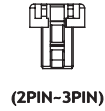
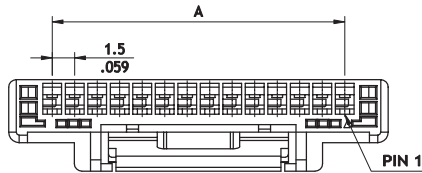
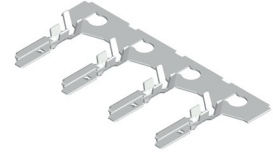
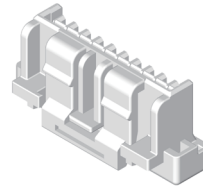

A = 1.5 x No. of spaces  
 B = A + 5.8  
 C = A + 2.75

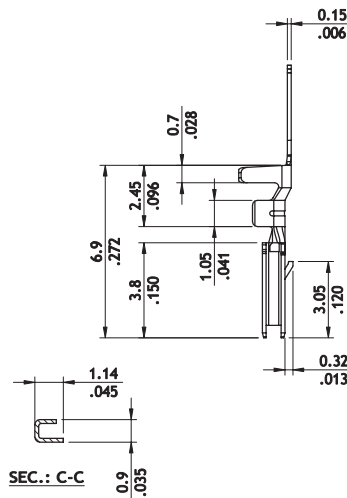
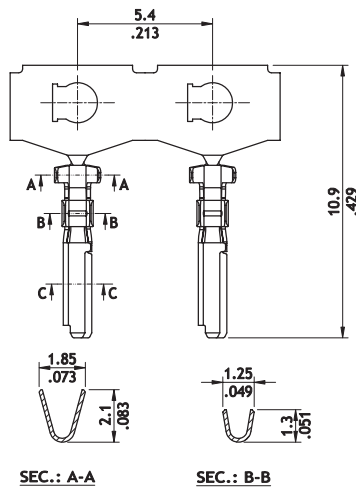
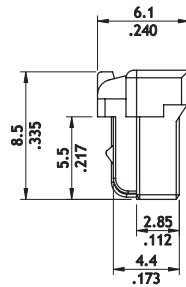
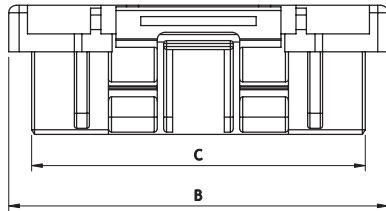

Wire Range	Insulation Diameter
AWG #24-#26	1.28 (.050) MAX.

**Ordering Code**

① CIDW ② 10 ③ S ④ 0000

- ① Series No.
- ② No. of Circuits : 02~15
- ③ S = Housing
- ④ Other Options:  
0000 = Color Nature

① CIDW ② T02 ③ 1 ④ P ⑤ E0

- ① Series No.
- ② Type: T02 = AWG # 24 ~ # 28
- ③ Plating Code: 1 = Tin over Nickel
- ④ Material: P =Phosphor Bronze
- ⑤ Plating method : E0 = Standard

CI

WIRE TO BOARD

**CIDW Series 1.5mm(.059") Wire to Board Connectors SMT Headers**

- ⊙ Clik-Mate PCB receptacle positive lock
- ⊙ Mate with CIDW housing
- ⊙ Insulator : High temperature plastic UL 94V- 0 , Color Nature
- ⊙ With tin plated

**RoHS** Compliant

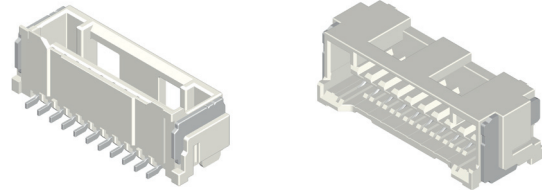

**P/N: CIDW\*\*M1HR0-LF**

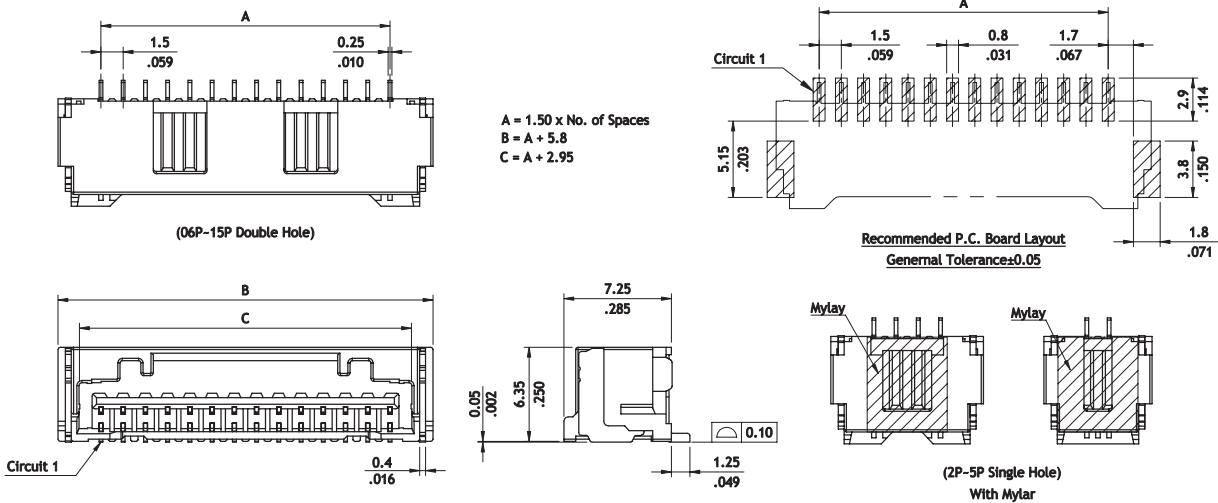

**P/N: CIDW\*\*M1VR0-LF**

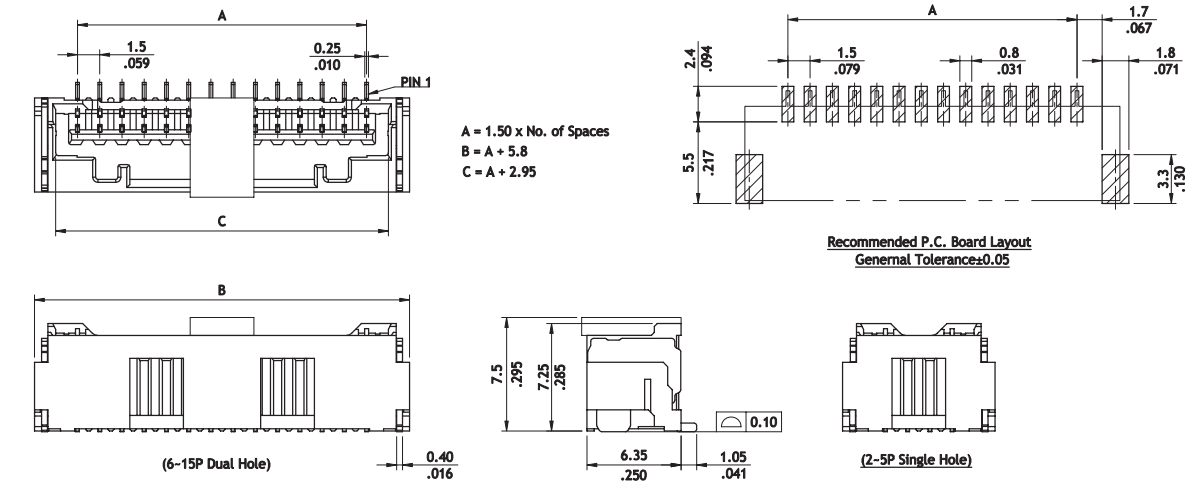

**Ordering Code**

① ② ③ ④ ⑤ ⑥ ⑦  
**CIDW 15 M 1 H R0 - LF**

- ① Series No.
- ② No. of Circuits: 02~15
- ③ Contact Type : M =SMT
- ④ Plating Code : 1 = Matte Tin over Nickel
- ⑤ Type : H = Right angle , V = Straight Type
- ⑥ Packing Option : R0 = Tape & Reel
- ⑦ LF = For Lead Free soldering processes

**CIEJ Series 1.00 mm(.059") Single Row Wire to Board Housing & Terminal**

- ⊙ Locking latch provide secure mating
- ⊙ Mate with CIEJ Header
- ⊙ Insulator : PA9T Nylon UL 94 V-0 , Color Nature
- ⊙ Terminal : Tin plated Phosphor Bronze

**RoHS** Compliant

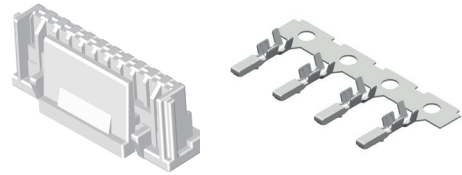

P/N: CIEJ\*\*SL000

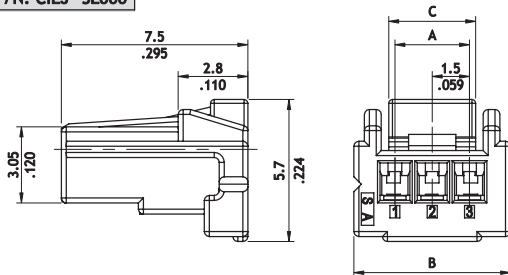

Circuits	Dimension			Circuits	Dimension		
	A	B	C		A	B	C
2	1.5(.059)	5.0(.197)	2.7(.106)	10	13.5(.531)	16.8(.661)	9.8(.386)
3	3.0(.118)	6.3(.248)	3.5(.138)	11	15.0(.591)	18.3(.720)	9.8(.386)
4	4.5(.177)	7.8(.307)	4.5(.177)	12	16.5(.650)	19.8(.780)	9.8(.386)
5	6.0(.236)	9.3(.366)	4.5(.177)	13	18.0(.709)	21.3(.839)	11.3(.445)
6	7.5(.295)	10.8(.425)	7.5(.295)	14	19.5(.768)	22.8(.898)	11.3(.445)
7	9.0(.354)	12.3(.484)	7.5(.295)	15	21.0(.827)	24.3(.957)	11.3(.445)
8	10.5(.413)	13.8(.543)	9.8(.386)	16	22.5(.886)	25.8(.016)	11.3(.445)
9	12.0(.472)	15.3(.602)	9.8(.386)				

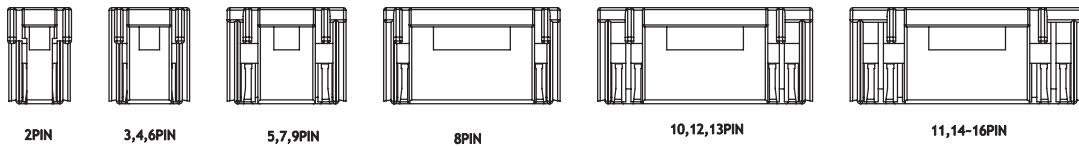

P/N: CIEJT021PPO

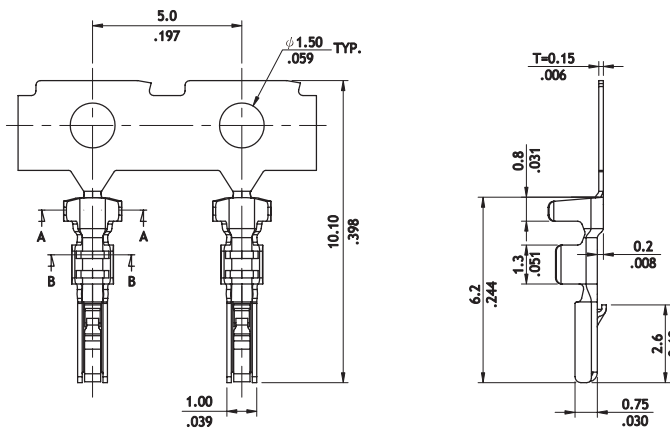

Wire Range	Insulation Diameter	Reel Qty
AWG #24-#28	1.20 (.047) MAX.	10,000 PCS.

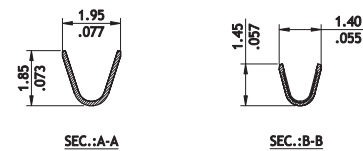

**Ordering Code**

① C ② IEJ ③ 04 ④ S ⑤ L 000

- ① Series No.
- ② No. of Circuits: 02~09
- ③ S = Receptacle
- ④ L = With Locking Latch
- ⑤ Option : 000 = Standard (Color Nature)

① C ② IEJ ③ T02 ④ 1 ⑤ P P0

- ① Series No.
- ② Type : T02= AWG #24~#28
- ③ Plating Code: 1 = Matte Tin over Nickel
- ④ Material : P = Phosphor Bronze
- ⑤ Option : P0 = Standard

**CIEJ Series 1.00 mm(.059") Single Row Wire to Board SMT Header**

- ⊙ Locking slots provide secure mating
- ⊙ Fix tab PCB hold-down strain-relief for SMT tail
- ⊙ Mate with CIEJ Housing
- ⊙ Insulator : PA9T Nylon UL 94 V-0 , Color Nature

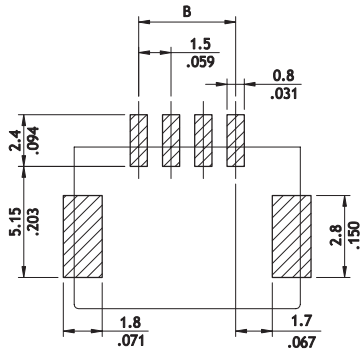
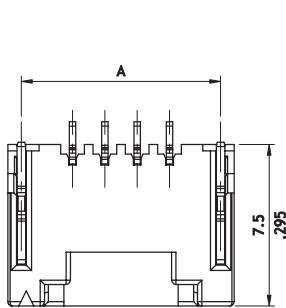
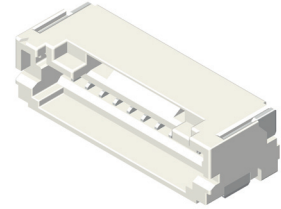

Recommended P.C. Board Layout  
Tolerance ±0.05

Circuits	Dimensions		
	A	B	C
2P	6.25(.246)	1.50(.059)	3.75(.148)
3P	7.75(.305)	3.00(.118)	5.25(.207)
4P	9.25(.364)	4.50(.177)	6.75(.266)
5P	10.75(.423)	6.00(.236)	8.25(.325)
6P	12.25(.482)	7.50(.295)	9.75(.384)
7P	13.75(.541)	9.00(.354)	11.25(.443)
8P	15.25(.600)	10.50(.413)	12.75(.502)
9P	16.75(.659)	12.00(.472)	14.25(.561)
10P	18.25(.719)	13.50(.531)	15.75(.620)
11P	19.75(.778)	15.00(.591)	17.25(.679)
12P	21.25(.837)	16.50(.650)	18.75(.738)
13P	22.75(.896)	18.00(.709)	20.25(.797)
14P	24.25(.955)	19.50(.768)	21.75(.856)
15P	25.75(1.013)	21.00(.828)	23.25(.915)
16P	27.25(1.073)	22.50(.886)	24.75(.974)

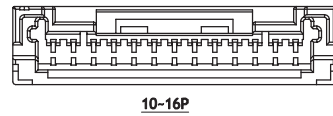
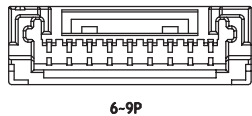
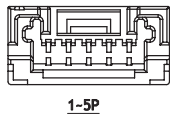
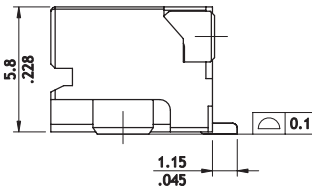
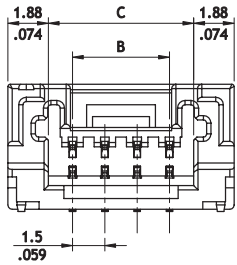

**Ordering Code**

① ② ③ ④ ⑤ ⑥ ⑦ ⑧  
**CIEJ 02 M 1 H R 0 - NH**

- ① Series No.
- ② No. of Circuits: 2~16
- ③ M = SMT Type Header
- ④ Plating Code: 1 = Tin over Nickel
- ⑤ Type : H = Side Entry
- ⑥ Packing Option : R=Tape & Reel packing
- ⑦ Options: 0 = Standard
- ⑧ NH = For Lead Free soldering process and Halogen-Free

**CI07 Series 1.80mm(.071") Wire to Board Connectors Housing & Terminal**

- ⊙ Mate with CI07 Header
- ⊙ Can be used with CI07 Crimp Clip Terminal
- ⊙ Insulator: Nylon66 UL 94V-0, Color Nature

RoHS Compliant

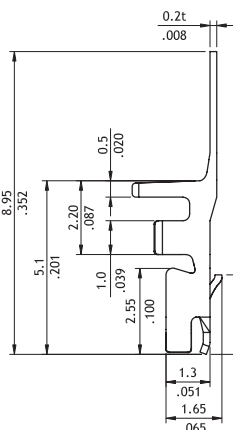
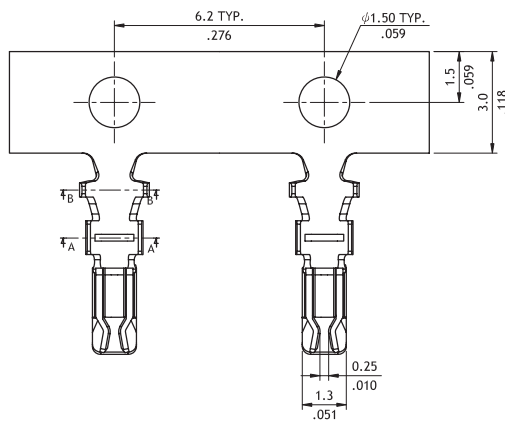
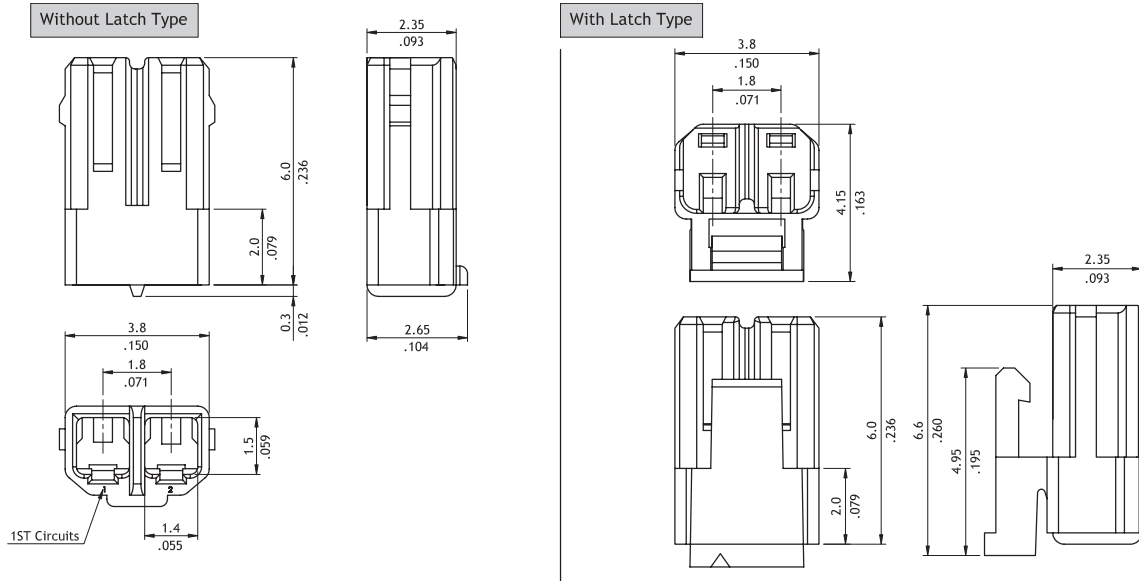
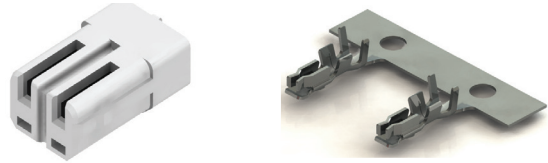

Wire Range	Insulation Diameter	Reel Qty
AWG #22-#26	0.95-1.3(mm) (.037-.051)	10,000 PCS
AWG #28-#30	0.88-0.95(mm) (.035-.037)	10,000 PCS

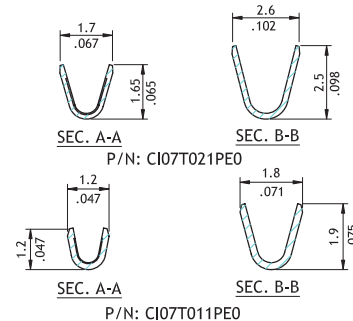

**Ordering Code**

① CI07 ② 02 ③ S ④ L0000 ⑤ -NH

- ① Series No.
- ② No. of Circuits: 02
- ③ S = Housing
- ④ Other Options:  
0000 = Without Locking Latch  
L000 = With Locking Latch
- ⑤ NH = For Lead Free and Halogen-Free

① C I 0 ② T 0 2 ③ 1 ④ P E P

- ① Series No.
- ② Type : T01 = AWG #28 ~ #30  
T02 = AWG #22 ~ #26
- ③ Plating Code: 1 = Tin over Nickel
- ④ Material: P = Phosphor Bronze
- ⑤ Plating method: E=Pre-tinned
- ⑥ Options: 0 = Standard

**CI07 Series 1.80mm(.071") Wire to Board Connectors SMT Headers**

- ⊙ Fixed tabs provide PCB hold-down
- ⊙ Mate with CI07 Housing
- ⊙ Insulator: High temperature plastic UL 94V-0, Color Nature

RoHS Compliant 



P/N	CI07**M1HRL-NH
-----	----------------

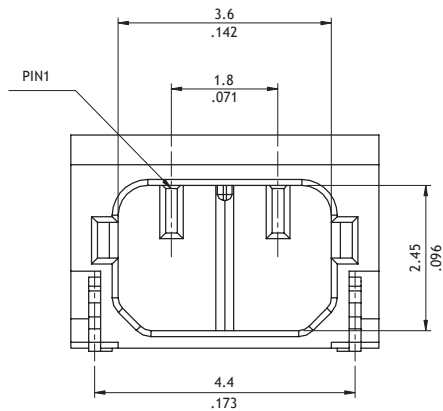
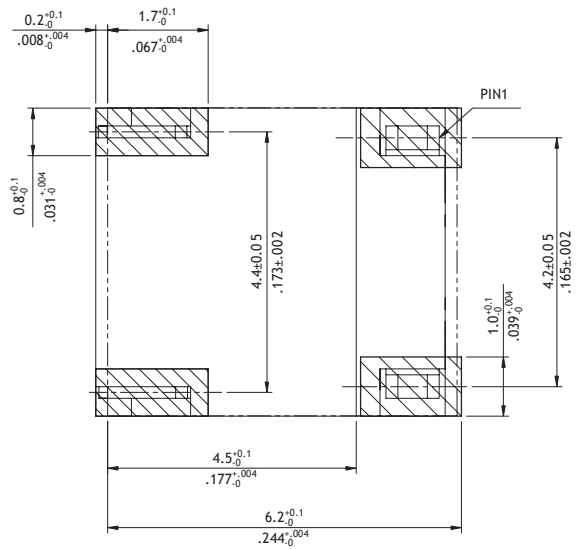
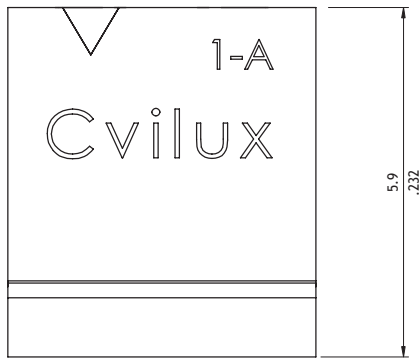

Recommended P.C.B. Board Layout

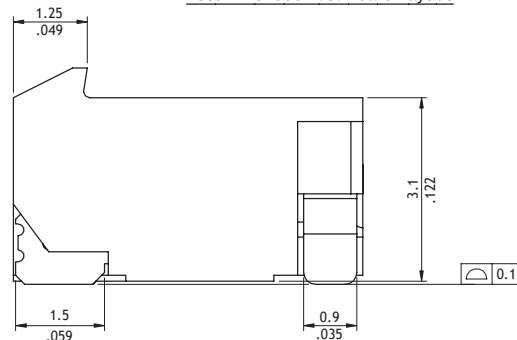

**Ordering Code**

① ② ③ ④ ⑤ ⑥ ⑦ ⑧  
**CI07 02 M 1 H R L - NH**

- ① Series No.
- ② No. of Circuits: 02
- ③ M = SMT Type
- ④ Plating Code : 1 = Matte Tin over Nickel

- ⑤ Type: H = Side Entry  
V = Top Entry
- ⑥ Packing Options: R = Tape & Reel
- ⑦ Other Options:  
L = With Locking Ramp,color Nature(Side entry type)  
I = With Locking Ramp,color Black (Top entry type)
- ⑧ NH = For Lead Free IR process and Halogen-Free

**CI01 Series 2.00mm(.079") Single Row Wire to Board Housing & Terminal Connector**

- ⊙ Low profile Latch Housing
- ⊙ Mate with CI01 Header
- ⊙ Can be used CI01 Crimp Clip Terminal
- ⊙ Insulator : Nylon 66 UL 94V-0 , Color Nature
- ⊙ Termial : Tin plated Phosphor Bronze

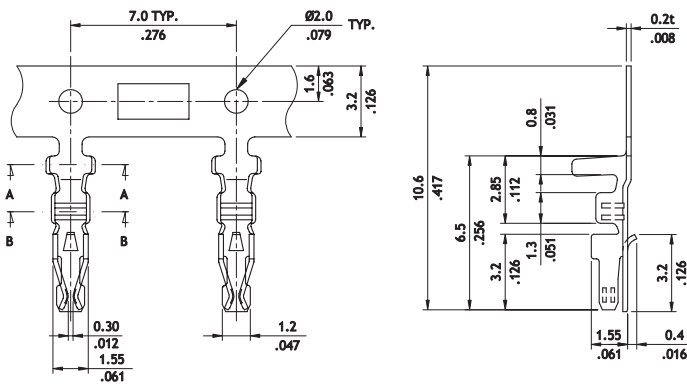
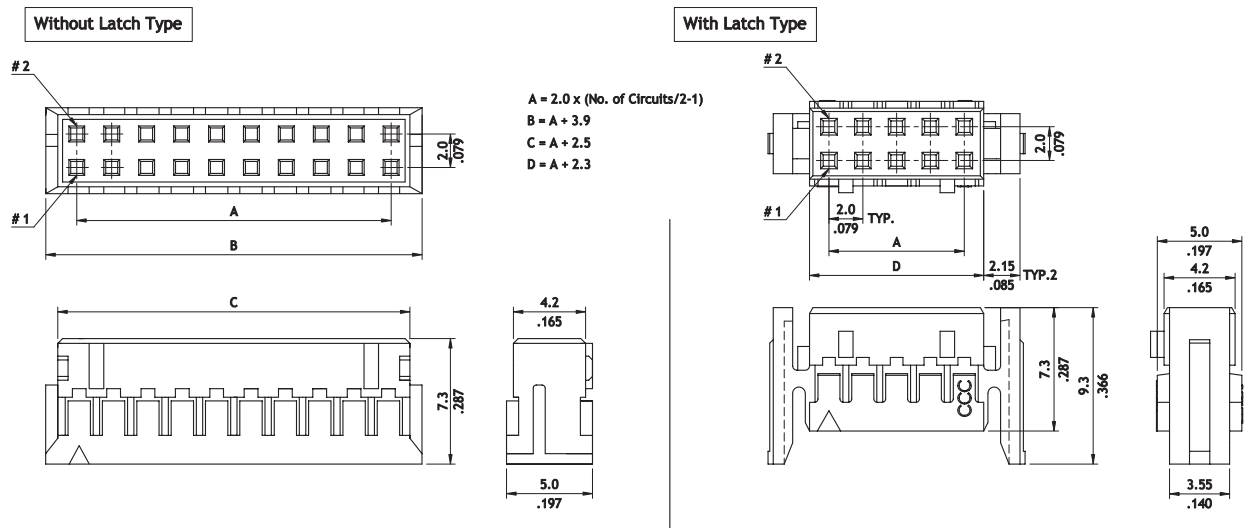
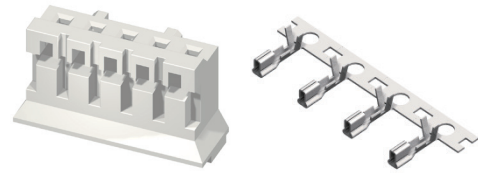

Wire Range	Insulation Diameter	Reel Q'ty
AWG #22-#28	1.60 (.063) MAX.	10,000 PCS.

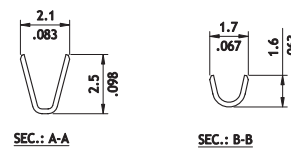

**Ordering Code**

① C ② 101 ③ 16 ④ S ⑤ 0000

- ① Series No.
- ② No. of Circuits: 02 ~ 16
- ③ S = Housing
- ④ Other Options: 0000 = Standard

① C ② I01 ③ T01 ④ 1 ⑤ P ⑥ E0

- ① Series No.
- ② Type: T01 =AWG#24~#28
- ③ Plating : 1= Tin over Nickel
- ④ Material: P =Phosphor Bronze
- ⑤ Other Option: E0=Standard

**CI01 Series 2.00mm(.079") Single Row IDC Housing and IDC Cable**

- ⊙ Low profile Latch Housing
- ⊙ Mate with CI01 Header
- ⊙ Can be used Crimp Clip Terminal
- ⊙ Insulator : Nylon 66 UL 94V-0 , Color Nature
- ⊙ Terminal : Tin plated Phosphor Bronze

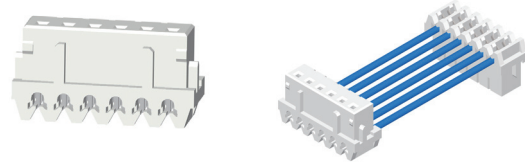

P/N CI01\*\*S1A\*0

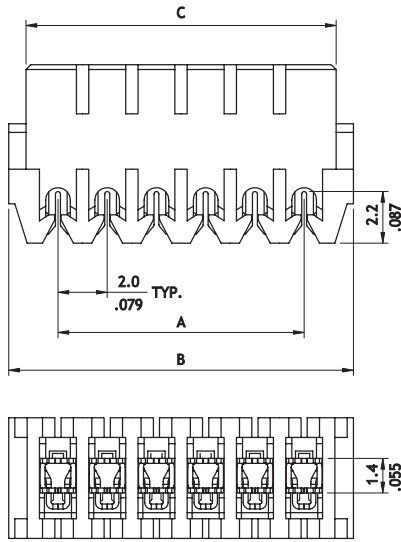

Wire Range	Insulation Diameter
AWG #26-#28	1.0 (.039) MAX.

A = 2.0 x No. of Spaces  
 B = A + 4.0  
 C = A + 2.6

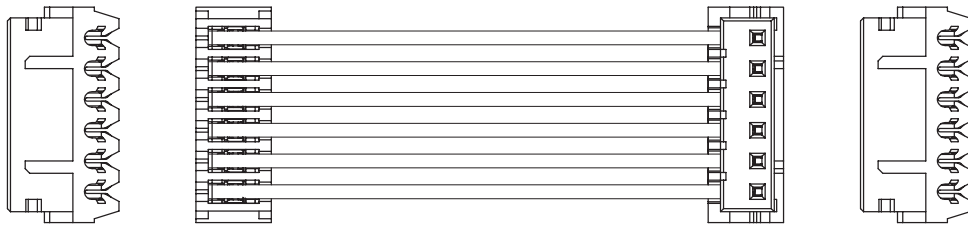
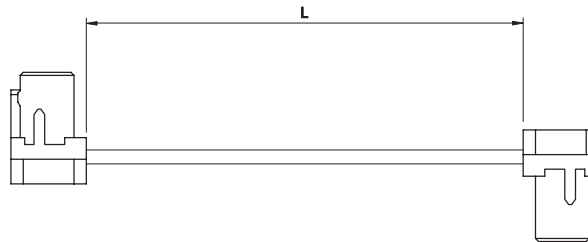

**Ordering Code**

① C ② I ③ 01 ④ 12 ⑤ S ⑥ 1 ⑦ A ⑧ 0 ⑨ 0

- ① Series No.
- ② No. of Circuits: 02~16
- ③ S = IDC Type
- ④ Plating Code: 1= Tin over Nickel
- ⑤ Color: A0 = Nature(#26)  
A6 = Green(#28)
- ⑥ Options: 0 = Standard

① Q ② H - ③ 01 ④ I ⑤ 12 ⑥ 0 ⑦ 100 ⑧ 00 ⑨ 0

- ① Series No.
- ② No. of Circuits: 02~16
- ③ L =Length : 40~1000 mm(0100=100 mm)
- ④ Wire Color : 00 = All pin counts of White Color  
01 =All pin counts of Black Color  
02 =All pin counts of Brown Color
- ⑤ Other Options: 0 = Standard

**CI01 Series 2.00mm(.079") Single Row Wire to Board DIP Headers**

- ⊙ Low profile, Pin kinked
- ⊙ With locking slots
- ⊙ Mate with CI01 Housing
- ⊙ Insulator : High temperature plastic UL 94V-0,Color Nature
- ⊙ With Tin plated 0.5mm square pin

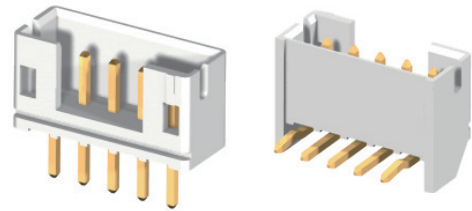

Top entry

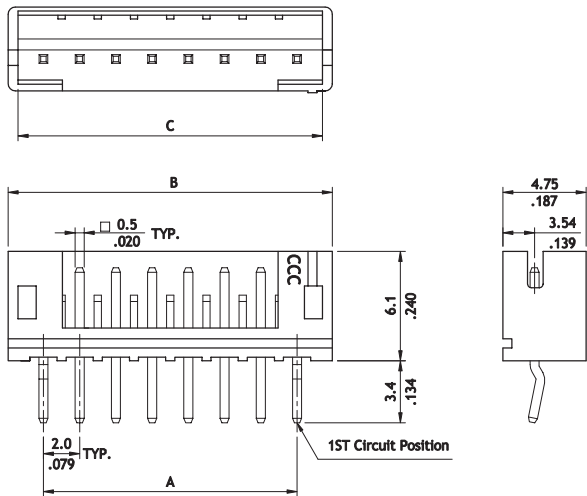

Side entry

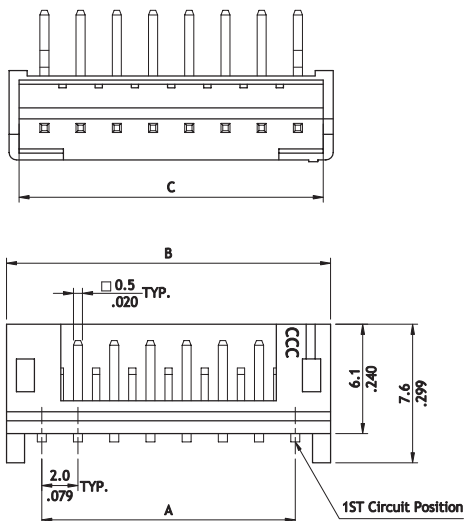

Circuits	Dimension		
	A	B	C
2	2.0(.079)	6.0(.236)	4.9(.193)
3	4.0(.157)	8.0(.315)	6.9(.272)
4	6.0(.236)	10.0(.394)	8.9(.350)
5	8.0(.315)	12.0(.472)	10.9(.429)
6	10.0(.394)	14.0(.551)	12.9(.508)
7	12.0(.472)	16.0(.630)	14.9(.587)
8	14.0(.551)	18.0(.709)	16.9(.665)
9	16.0(.630)	20.0(.787)	18.9(.744)
10	18.0(.709)	22.0(.866)	20.9(.823)
11	20.0(.787)	24.0(.945)	22.9(.902)
12	22.0(.866)	26.0(1.024)	24.9(.980)
13	24.0(.945)	28.0(1.102)	26.9(1.059)
14	26.0(1.024)	30.0(1.181)	28.9(1.138)
15	28.0(1.102)	32.0(1.260)	30.9(1.217)
16	30.0(1.181)	34.0(1.338)	32.9(1.295)

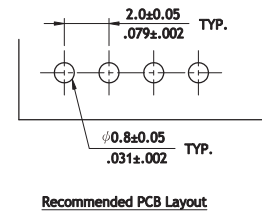

**Ordering Code**

① CI01    ② 16    ③ P    ④ 1    ⑤ V    ⑥ K0    ⑦ -NH

- ① Series No.
- ② No. of Circuits: 02 ~ 16
- ③ P = DIP Type
- ④ Plating Code: 1 = Matte Tin over Nickel
- ⑤ Type: V = Top entry  
H = Side entry
- ⑥ Other Options: 00 = Without Pin Kinked  
K0 = With Pin Kinked (Standard)  
\*Special options consult manufacturer
- ⑦ NH = For Lead Free soldering process and Halogen-Free

CI  
WIRE TO BOARD

**CI01 Series 2.00mm(.079") Single Row Wire to Board SMT Headers**

- ⊙ Polarization and Low-profile
- ⊙ Locking slots provide secure mating
- ⊙ Fixed tabs provide PCB hold-down
- ⊙ Mate with CI01 Housing
- ⊙ Insulator: High temperature plastic UL 94V-0, Color Nature
- ⊙ Termianl: Tin plated Brass

RoHS Compliant 

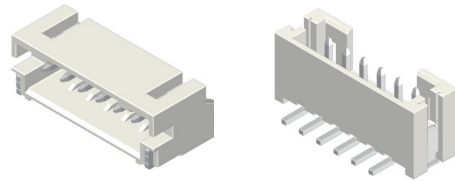

**Top entry**

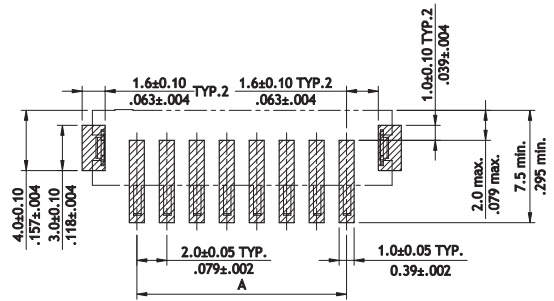
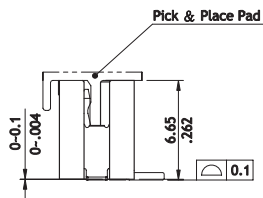
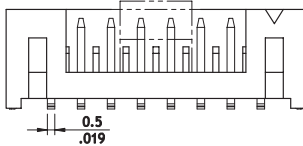
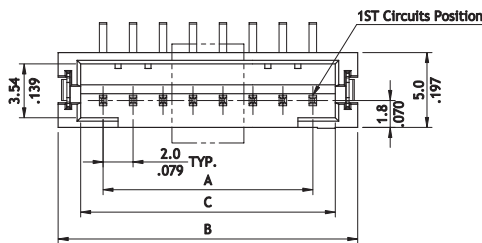

Recommended P.C. Board Layout

Circuits	Dimension		
	A	B	C
2	2.0(.079)	8.0(.315)	5.0(.197)
3	4.0(.157)	10.0(.394)	7.0(.276)
4	6.0(.236)	12.0(.472)	9.0(.354)
5	8.0(.315)	14.0(.551)	11.0(.433)
6	10.0(.394)	16.0(.630)	13.0(.512)
7	12.0(.472)	18.0(.709)	15.0(.591)
8	14.0(.551)	20.0(.787)	17.0(.669)
9	16.0(.630)	22.0(.866)	19.0(.748)
10	18.0(.709)	24.0(.945)	21.0(.827)
11	20.0(.787)	26.0(1.024)	23.0(.906)
12	22.0(.866)	28.0(1.102)	25.0(.984)
13	24.0(.945)	30.0(1.181)	27.0(1.063)
14	26.0(1.024)	32.0(1.260)	29.0(1.142)
15	28.0(1.102)	34.0(1.339)	31.0(1.220)
16	30.0(1.181)	36.0(1.417)	33.0(1.299)

**Side entry**

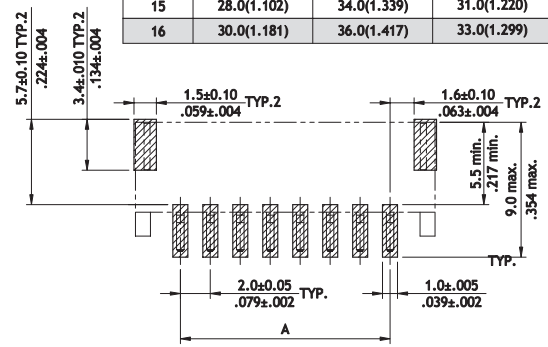
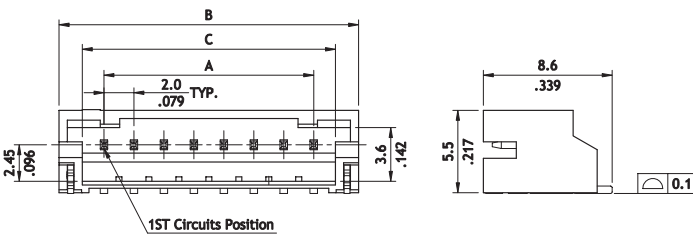
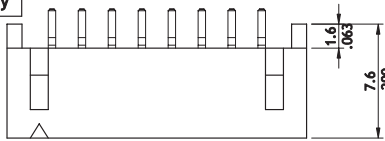

Recommended P.C. Board Layout

**Ordering Code**

① ② ③ ④ ⑤ ⑥ ⑦ ⑧  
**CI01 15 M 1 V R 0 - NH**

- ① Series No.
- ② No. of Circuits: Top Entry: 02 ~ 15  
Side Entry: 02 ~ 16
- ③ M = SMT Type
- ④ Plating Code: 1 = Matte Tin over Nickel
- ⑤ Type : V = Top Entry , H = Side Entry

- ⑥ Packing Options: T = Tube  
R = Tape & Reel  
(Top Entry type with pick & place Pad)
- ⑦ Other Options: 0 = Standard  
Z = Special Insulation Material  
\*Special options consult manufacturer
- ⑧ NH = For Lead Free IR process and Halogen-Free

**CI01 Series 2.00mm(.079") Single Row Wire to Board Housing & SMT Header**

- ⊙ With locking latch provide secure mating
- ⊙ Fixed tabs provide PCB hold-down
- ⊙ Insulator: High temperature plastic UL 94V-0 , Color Nature
- ⊙ Housing: Mate with CI06 terminal (P/N: CI06T011PE0)

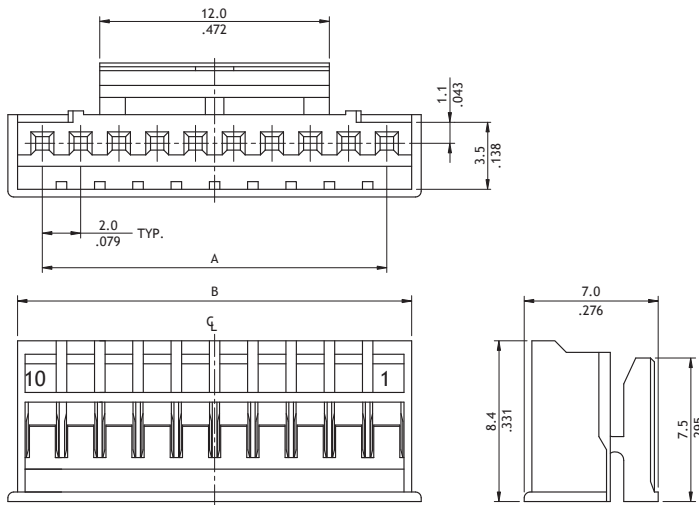
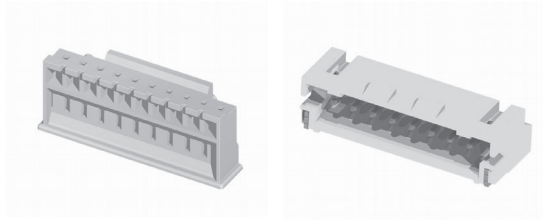

Circuits	Dimension	
	A	B
10	18.0(.709)	20.6(.811)
12	22.0(.866)	24.6(.969)
14	26.0(1.024)	28.6(1.126)
16	30.0(1.181)	32.6(1.283)

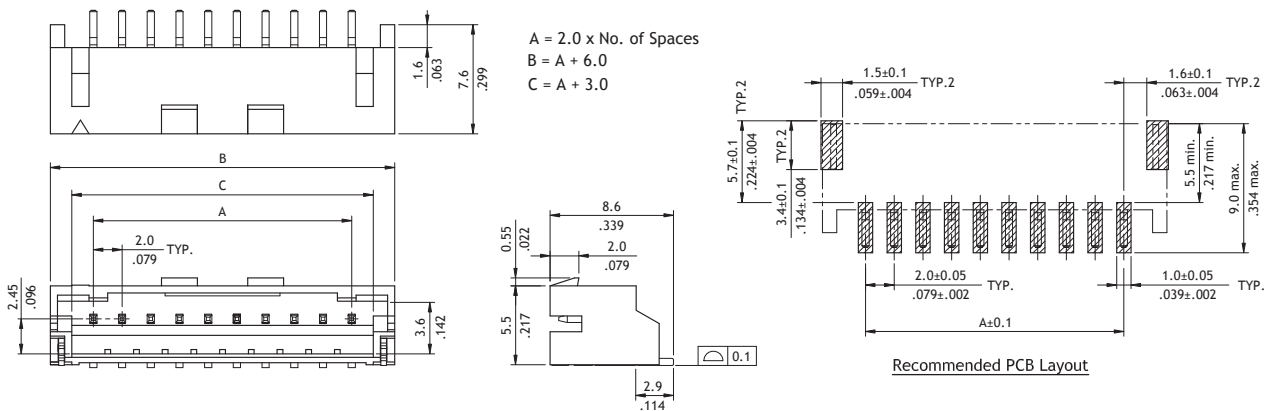

Ordering Code					Ordering Code							
①	②	③	④	⑤	①	②	③	④	⑤	⑥	⑦	⑧
CI01	16	S	00L	0	CI01	16	M	1	H	R	L	-NH
① Series No.	② No. of Circuits: 10, 12, 14, 16	③ S = Housing	④ Latch Options: 00L = With Locking Latch	⑤ Other Options: 0 = Standard (Color Nature) *Special options consult manufacturer	① Series No.	② No. of Circuits: 10, 12, 14, 16	③ M = SMT Type	④ Plating Code: 1 = Matte Tin over Nickel	⑤ Type: H = Side Entry	⑥ Packing Options: R = Tape & Reel ; T = Tube	⑦ Other Options: L = With Locking Latch	⑧ NH = For Lead Free soldering process and Halogen-Free

**CI01 Series 2.00mm(.079") Dual Row Wire to Board Housing & Terminal**

- ⊙ Low profile latch with housing
- ⊙ Mate with CI01, CH71, CH72, CH74, CH75 header
- ⊙ Can be used with CI01 crimp clip terminal (P/N: CI01TD21PE0)
- ⊙ Insulator: Nylon 66 UL 94V-0, Color Nature

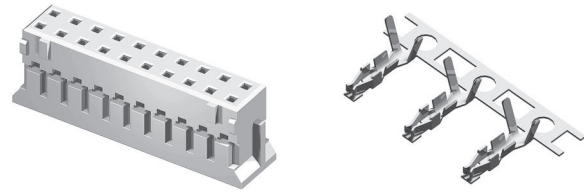

CI

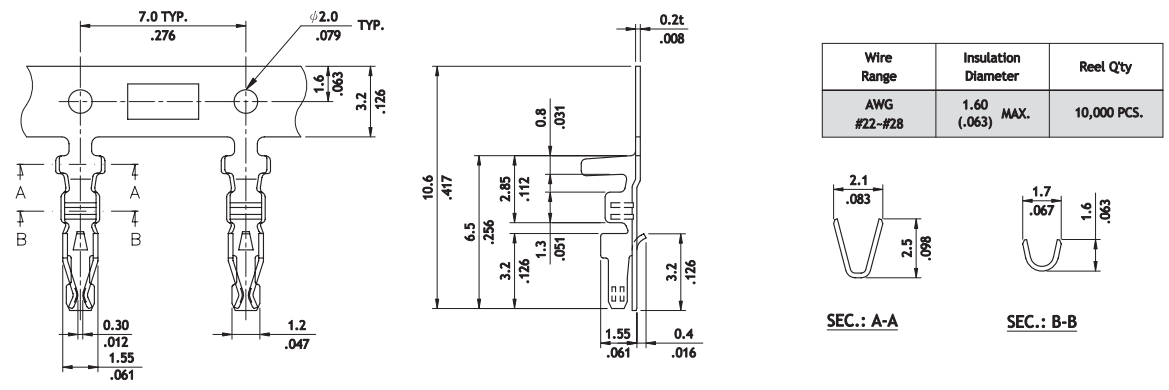
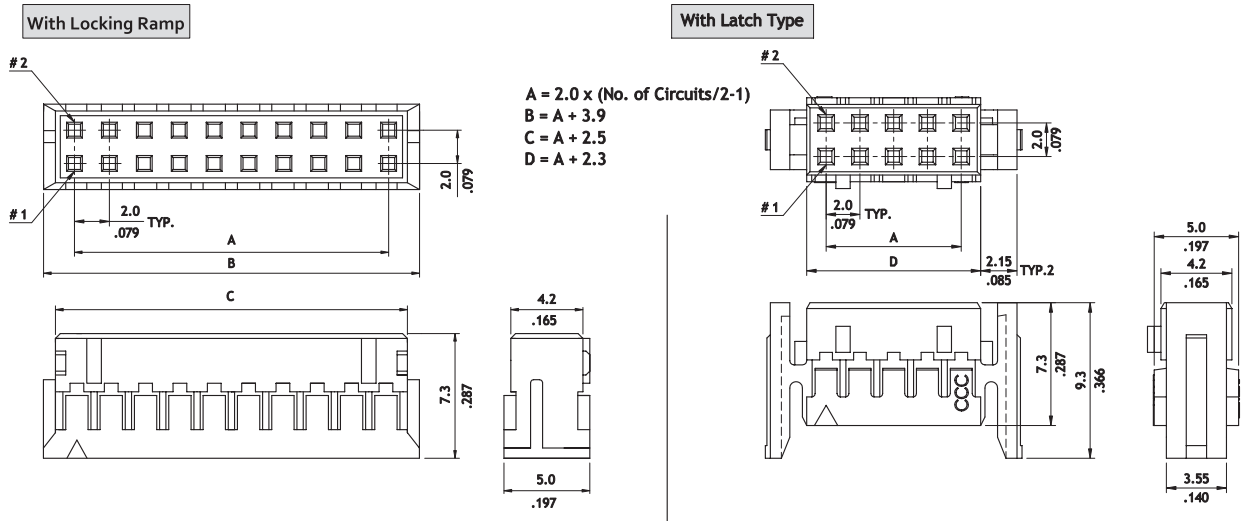

**Ordering Code**

① ② ③ ④ ⑤

C I 0 1 1 6 S D 0 0 0

① ② ③ ④ ⑤

C I 0 1 T D 2 1 P E 0

- ① Series No.
  - ② No. of Circuits: 06 ~ 34
  - ③ S = Housing
  - ④ D0 = Dual Row Type
  - ⑤ Other Options: 00 = With Locking Ramp  
L0 = With Locking Latch
- \*Special options consult manufacturer

- ① Series No.
- ② Type: TD2 = AWG #22 ~ #28
- ③ Plating Code: 1 = Tin over Nickel
- ④ Material: P = Phosphor Bronze
- ⑤ Other Options: E0 = Standard

WIRE TO BOARD

**CI01 Series 2.00mm(.079") Dual Row Wire to Board Connectors DIP Headers**

- ⊙ With locking slots
- ⊙ Mate with CI01 Dual Row Housing
- ⊙ Insulator: High temperature plastic UL 94V-0, Color Nature
- ⊙ With Tin plated 0.5mm square pin

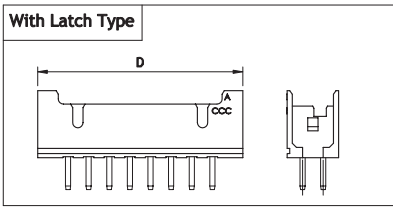
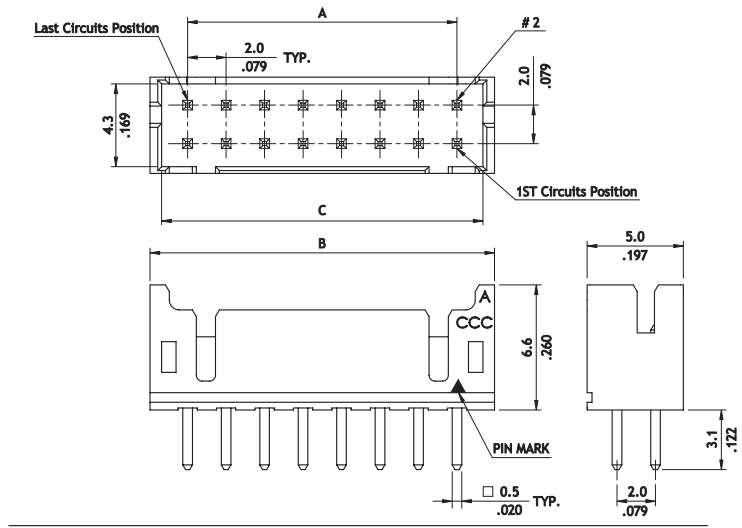
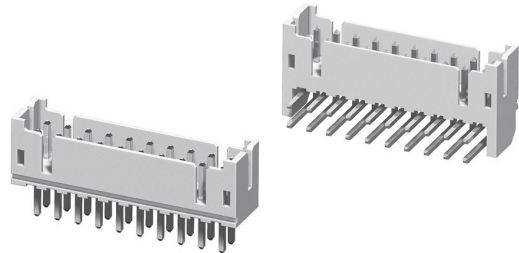

A = 2.0 x No. of Spaces  
 B = A + 3.9  
 C = A + 2.7  
 D = A + 5.9

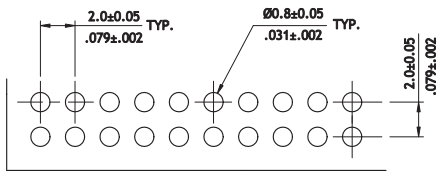

Recommended P.C. Board Layout

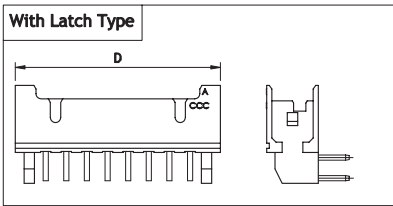
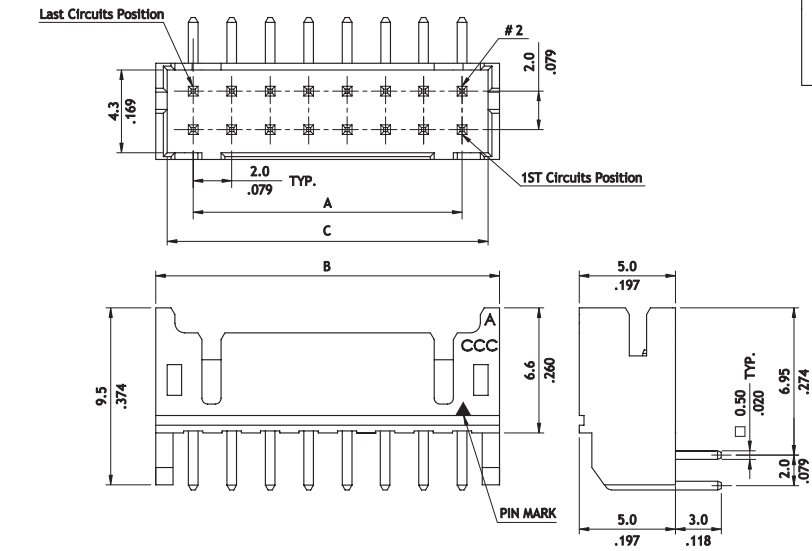

<b>Ordering Code</b>	①	②	③	④	⑤	⑥	⑦	⑧
	<b>CI01</b>	<b>34</b>	<b>P</b>	<b>1</b>	<b>V</b>	<b>D</b>	<b>0</b>	<b>NH</b>

① Series No.  
 ② No. of Circuits: 06 ~ 34  
 ③ P = DIP Type  
 ④ Plating Code: 1=Matte Tin over Nickel  
 ⑤ Type:V=Straight  
           H=Right Angle  
 ⑥ D=Dual Row Header  
 ⑦ Other Options: 0 = With Locking Slot  
                           L = With Locking Ramp  
 ⑧ NH = For Lead Free soldering process and Halogen-Free  
 \*Special options consult manufacturer

CI02 Series 2.00mm(.079") Board In Connectors

- ⊙ Low profile Housing
- ⊙ Mate with CI02 Crimp board Terminal
- ⊙ Insulator: Nylon 66 UL 94V-0, Color Nature
- ⊙ Terminal: Tin plated Copper alloy

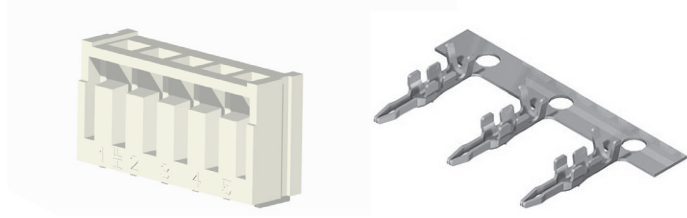

CI

P/N CI02\*\*S0000

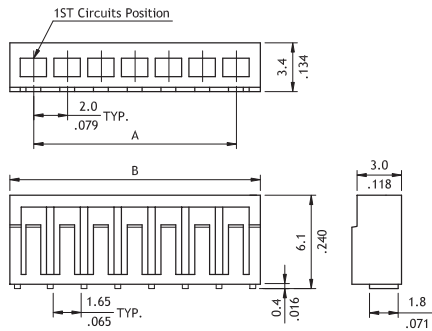

P/N CI02\*\*S000H

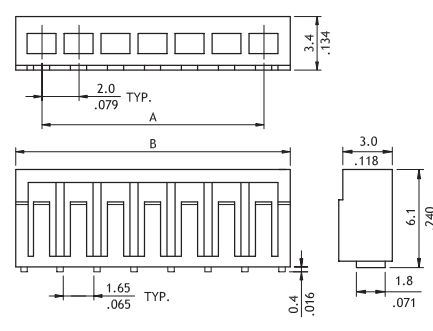

Circuits	Dimension	
	A	B
2	2.0(.079)	5.2(.205)
3	4.0(.157)	7.2(.283)
4	6.0(.236)	9.2(.362)
5	8.0(.315)	11.2(.441)
6	10.0(.394)	13.2(.520)
7	12.0(.472)	15.2(.598)
8	14.0(.551)	17.2(.677)
9	16.0(.630)	19.2(.756)
10	18.0(.709)	21.2(.835)
11	20.0(.787)	23.2(.913)
12	22.0(.866)	25.2(.992)
13	24.0(.945)	27.2(1.071)
14	26.0(1.024)	29.2(1.150)
15	28.0(1.102)	31.2(1.228)
16	30.0(1.181)	33.2(1.307)

P/N CI02T011\*E0

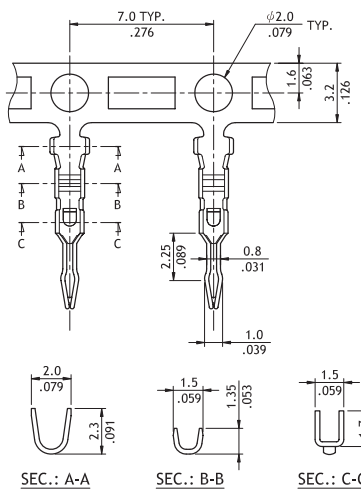

P/N CI02T021\*E0

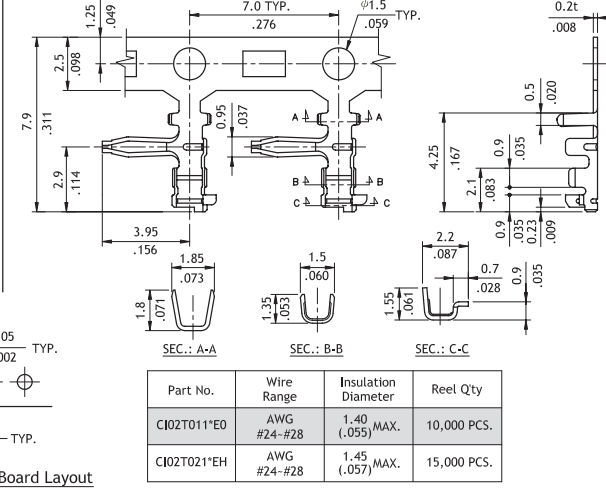

Part No.	Wire Range	Insulation Diameter	Reel Qty
CI02T011*E0	AWG #24-#28	1.40 (.055) MAX.	10,000 PCS.
CI02T021*EH	AWG #24-#28	1.45 (.057) MAX.	15,000 PCS.

Recommended P.C. Board Layout

Ordering Code

① CI02 ② 20 ③ S ④ 0000-A

- ① Series No.
- ② No. of Circuits: 02 ~ 20
- ③ S = Housing
- ④ Other Options:  
0000-A = For Straight Terminal  
000H-A = For Right Angle Terminal  
\*Special options consult manufacturer

① CI02 ② T02 ③ 1 ④ P ⑤ P0

- ① Series No.
- ② Type: T02 = AWG #24 ~ #28 (Straight)  
T02 = AWG #26 ~ #28 (Right Angle)
- ③ Plating Code: 1 = Tin over Nickel
- ④ Material: P = Phosphor Bronze ; B = Brass
- ⑤ Terminal Style: P0 = Straight  
PH = Right Angle

WIRE TO BOARD

**CI06 Series 2.00mm(.079") Wire to Board Connectors Housing & Terminal**

- ⊙ With locking latch provides secure mating
- ⊙ Mate with CI06 Header
- ⊙ Can be used with CI06 Crimp Clip Terminal
- ⊙ Insulator: Nylon 66 UL 94V-0, Color Nature

RoHS Compliant

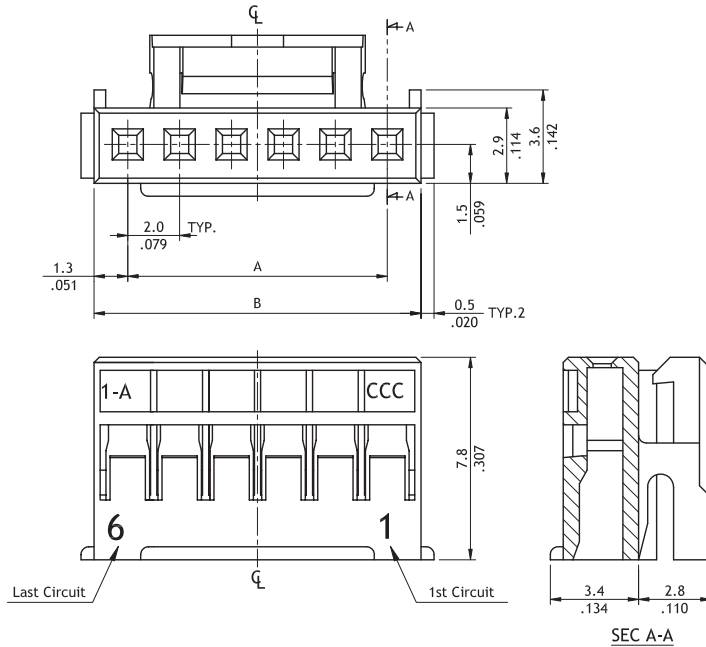
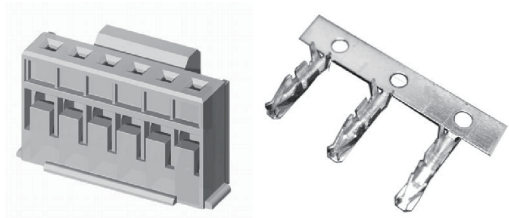

Circuits	Dimension	
	A	B
2	2.0(.079)	4.6(.181)
3	4.0(.157)	6.6(.260)
4	6.0(.236)	8.6(.339)
5	8.0(.315)	10.6(.417)
6	10.0(.394)	12.6(.496)
7	12.0(.472)	14.6(.575)
8	14.0(.551)	16.6(.654)
9	16.0(.630)	18.6(.732)
10	18.0(.709)	20.6(.811)
11	20.0(.787)	22.6(.890)
12	22.0(.866)	24.6(.969)
13	24.0(.945)	26.6(1.047)
14	26.0(1.024)	28.6(1.126)
15	28.0(1.102)	30.6(1.205)
16	30.0(1.181)	32.6(1.283)

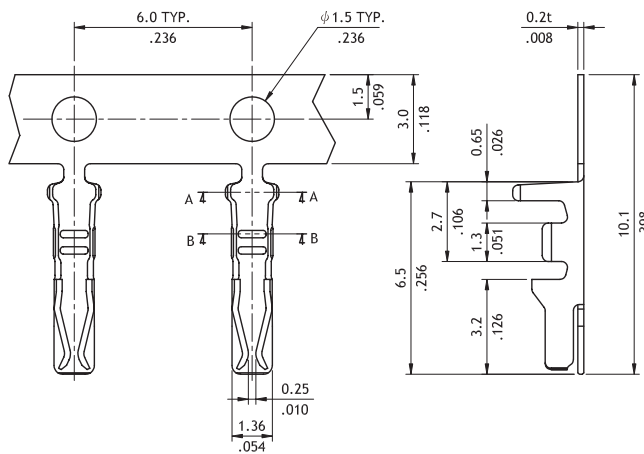

Wire Range	Insulation Diameter	Reel Qty
AWG #24-#30	0.80 Min. (.031) 1.45 MAX. (.057)	10,000 PCS.

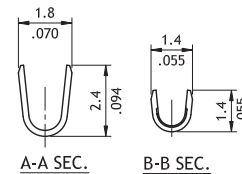

**Ordering Code**

① CI06 ② 16 ③ S ④ 0000

① CI06 ② T01 ③ 1 ④ P ⑤ E0

- ① Series No.
- ② No. of Circuits: 02 ~ 16
- ③ S = Housing
- ④ Other Options: 0000 = Standard  
\*Special options consult manufacturer
- ① Series No.
- ② Type: T01 = AWG #24 ~ #30
- ③ Plating Code: 1 = Tin over Nickel
- ④ Material: P = Phosphor Bronze
- ⑤ Other Options: E0 = Standard

**CI06 Series 2.00mm(.079") Wire to Board Connectors DIP & SMT Headers**

- ⊙ With locks provide secure mating
- ⊙ Mate with CI06 housing
- ⊙ Insulator: High temperature plastic UL 94V-0 , Color Nature
- ⊙ With Tin plated 0.5mm square pin

RoHS Compliant 

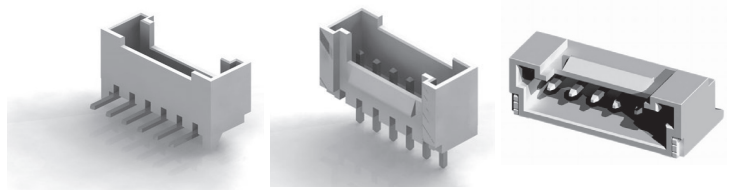

**Straight DIP Type**

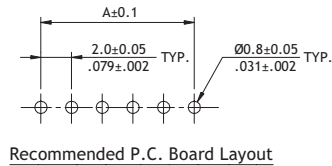
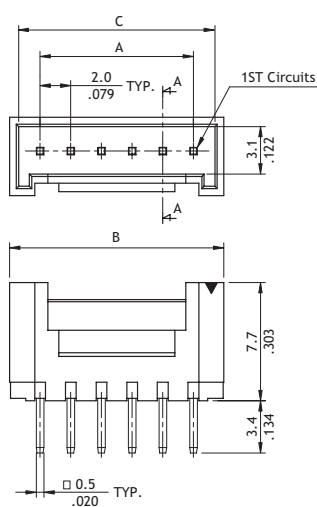

**Right angle DIP Type**

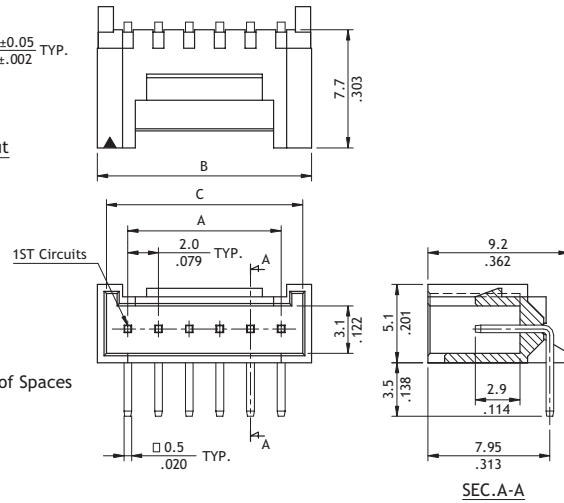

A = 2.0 x No. of Spaces  
 B = A + 3.96  
 C = A + 2.8

**Right angle SMT Type**

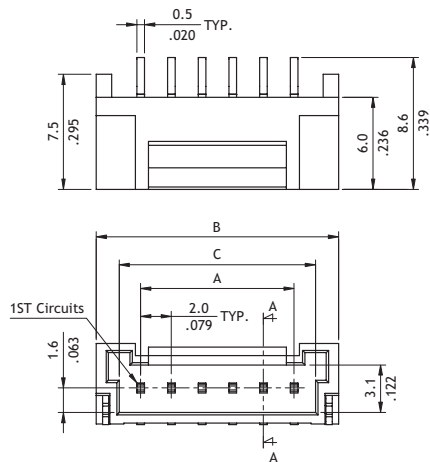

A = 2.0 x No. of Spaces  
 B = A + 5.8  
 C = A + 2.8

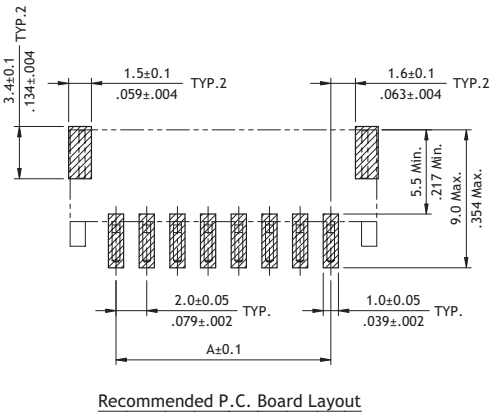

**Ordering Code**

① ② ③ ④ ⑤ ⑥ ⑦  
**C I 06 1 6 P 1 V 00 - NH**

- ① Series No.
  - ② No. of Circuits: 02 ~ 16
  - ③ P = DIP Type
  - ④ Plating Code: 1 = Matte Tin over Nickel
  - ⑤ Type: V = Straight ; H = Right Angle
  - ⑥ Other Options: 00 = Standard
  - ⑦ NH = For Lead Free soldering process and Halogen-Free
- \*Special options consult manufacturer

① ② ③ ④ ⑤ ⑥ ⑦ ⑧  
**C I 06 1 6 M 1 H R 0 - NH**

- ① Series No.
- ② No. of Circuits: 02 ~ 16
- ③ M = SMT Type
- ④ Plating Code: 1 = Matte Tin over Nickel
- ⑤ Type: H = Side Entry
- ⑥ Packing: R = Tape & Reel ; T = Tube
- ⑦ Other Options: 0 = Standard
- ⑧ NH = For Lead Free soldering process and Halogen-Free

**CI08 Series 2.00mm(.079") Wire to Board Connectors SMT & DIP Headers**

- ⊙ 3.0mm above the board
- ⊙ Insulation: High temperature plastic UL 94V-0, Color Black
- ⊙ With metal fixed tabs to secure connector in place

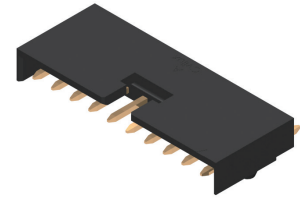

**SMT TYPE**

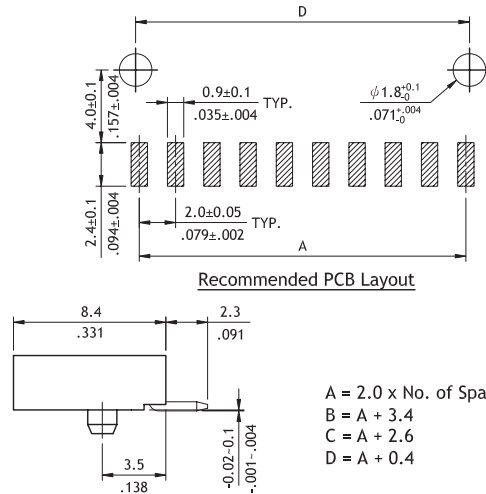
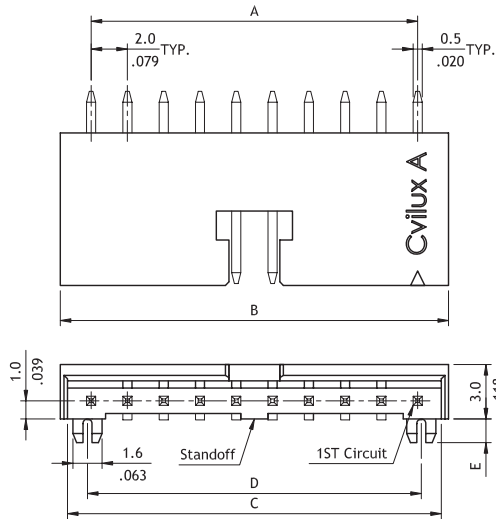

**DIP TYPE**

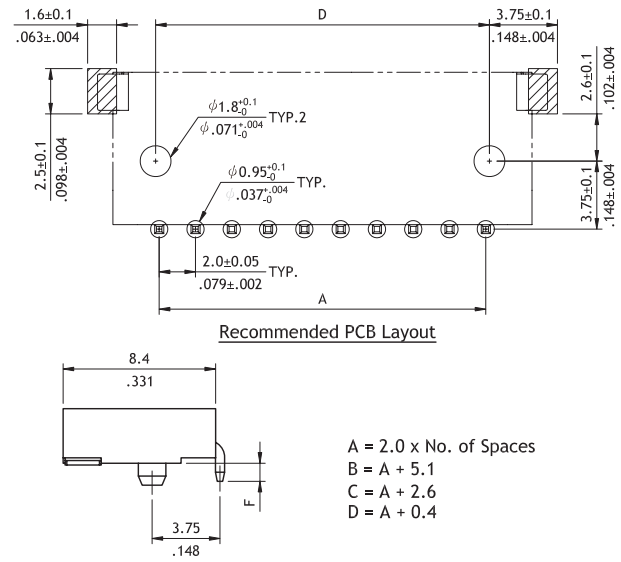
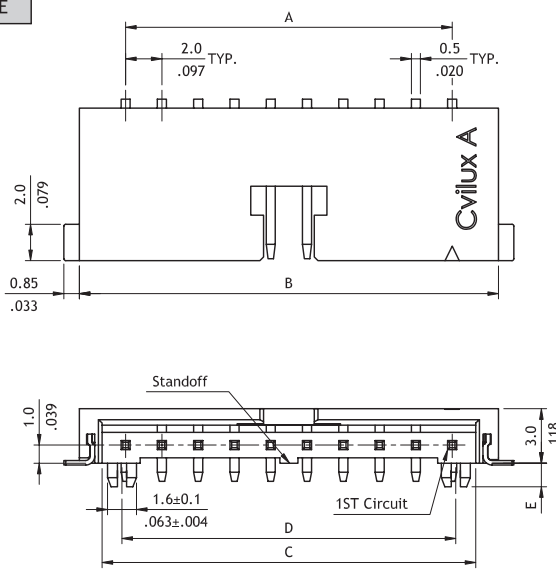

**Ordering Code**

① ② ③ ④ ⑤ ⑥ ⑦ ⑧  
**CI08 17 P 1 H R 0 - NH**

- ① Series No.
- ② No. of Circuits: 03 ~ 17
- ③ P= DIP Type  
M= SMT Type
- ④ Plating Code: 1= Matte Tin over Nickel  
2= Gold flash over Nickel
- ⑤ Type: H=Side Entry
- ⑥ Packing Option: R= Tape & Reel
- ⑦ Other Options :  
SMT Type  
0: DIM.E=0.9 1: DIM.E=1.0  
DIP Type  
0: DIM.E=0.9 DIM.F=1.0  
1: DIM.E=0.9 DIM.F=1.2  
2: DIM.E=1.3 DIM.F=1.0  
4: DIM.E=1.3 DIM.F=1.2
- ⑧ NH=For Lead Free Soldering Process and Halogen-Free

**CI10 Series 2.00mm(.079") Wire to Board Connectors Housing & Terminal**

- ⊙ Low profile Housing
- ⊙ Mate with CI01 Crimp board Terminal
- ⊙ Insulator: Nylon 66 UL 94V-0, Color Nature
- ⊙ Terminal: Tin plated Copper alloy

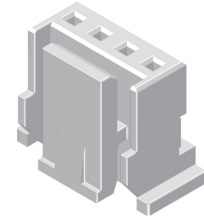

RoHS Compliant

CI

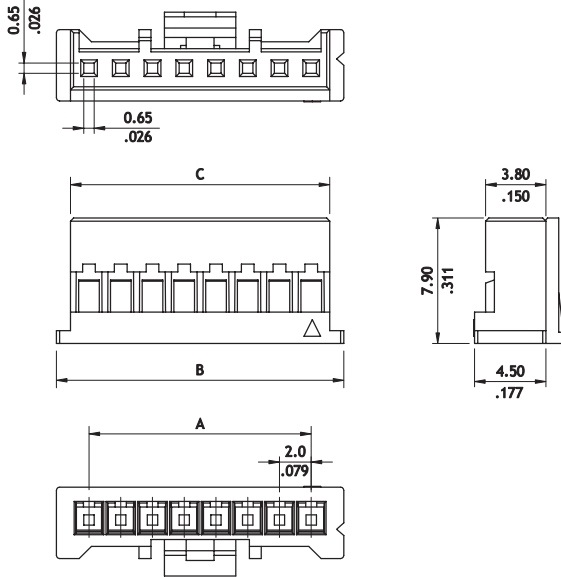

Circuits No.	Dimensions		
	A	B	C
02	2.00(.079)	6.10(.240)	4.34(.171)
03	4.00(.157)	8.10(.319)	6.34(.250)
04	6.00(.236)	10.10(.398)	8.34(.328)
05	8.00(.315)	12.10(.476)	10.34(.407)
06	10.00(.394)	14.10(.555)	12.34(.486)
07	12.00(.472)	16.10(.634)	14.34(.565)
08	14.00(.551)	18.10(.713)	16.34(.643)
09	16.00(.630)	20.10(.791)	18.34(.722)
10	18.00(.709)	22.10(.870)	20.34(.801)
11	20.00(.787)	24.10(.949)	22.34(.880)
12	22.00(.866)	26.10(1.028)	24.34(.958)
13	24.00(.945)	28.10(1.106)	26.34(1.037)
14	26.00(1.024)	30.10(1.185)	28.34(1.116)
15	28.00(1.102)	32.10(1.264)	30.34(1.194)
16	30.00(1.181)	34.10(1.343)	32.34(1.273)

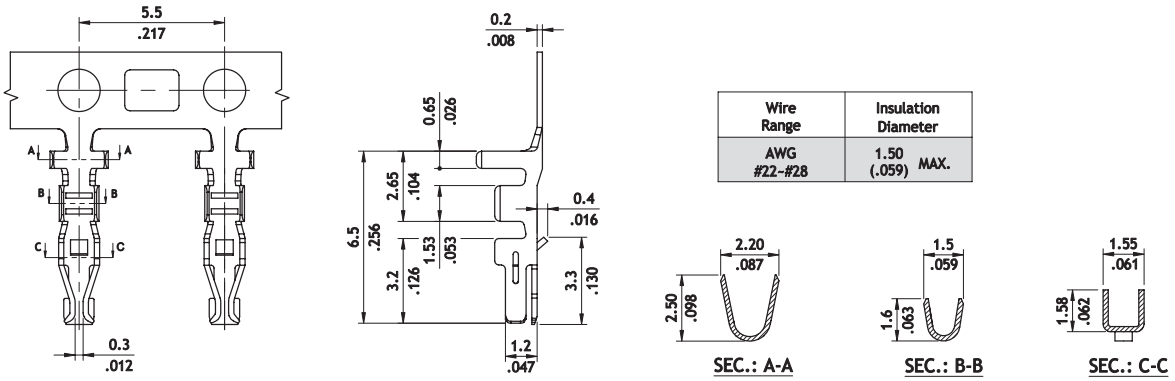

Wire Range	Insulation Diameter
AWG #22-#28	1.50 (.059) MAX.

**Ordering Code**

① ② ③ ④  
**C I 10 0 2 S L 0 0 A**

① ② ③ ④ ⑤  
**C I 1 0 T 0 2 1 P E A**

- ① Series No.
- ② No. of Circuits: 02~06 , 10 , 12 , 15 , 16  
\*see above table
- ③ S= Connector Housing
- ④ Other Option : L00A =Locking Latch (Standard)

- ① Series No.
- ② Type: T02 = AWG #22~#28
- ③ Plating Code: 1 = Tin over Nickel
- ④ Material : P=Phosphor Bronze
- ⑤ Option : EA = Standard

WIRE TO BOARD

**CI10 Series 2.00mm(.079") Single Row Wire to Board Connectors DIP & SMT Headers**

- ⊙ Low profile , Pin kinked
- ⊙ With locks provide secure mating
- ⊙ Insulator: Nylon UL 94V-0 , Color Nature
- ⊙ Terminal :Tin plated 0.5mm square pin

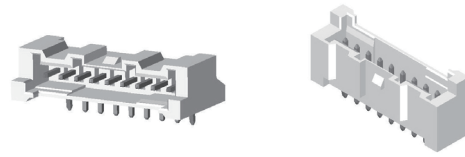

RoHS Compliant

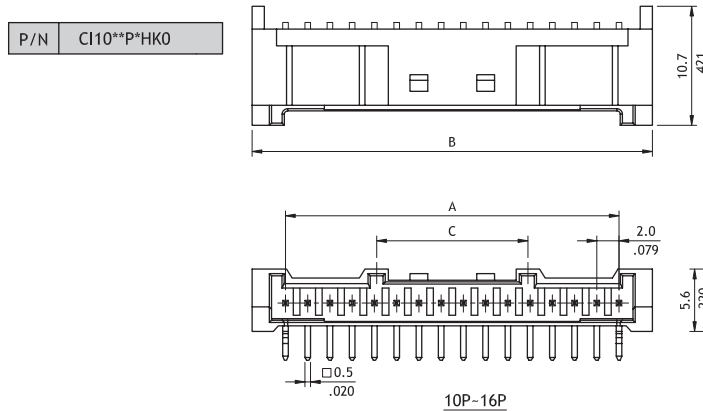

Circuits	Dimension		
	A	B	C
2	2.00(.079)	8.0(.315)	
3	4.00(.157)	10.0(.394)	.....
4	6.00(.236)	12.0(.472)	
5	8.00(.315)	14.0(.551)	
6	10.00(.394)	16.0(.630)	
7	12.00(.472)	18.0(.709)	7.00(.276)
8	14.00(.551)	20.0(.787)	
9	16.00(.630)	22.0(.866)	
10	18.00(.709)	24.0(.945)	
11	20.00(.787)	26.0(1.024)	
12	22.00(.866)	28.0(1.102)	
13	24.00(.945)	30.0(1.181)	13.60(.535)
14	26.00(1.024)	32.0(1.260)	
15	28.00(1.102)	34.0(1.339)	
16	30.00(1.181)	36.0(1.417)	

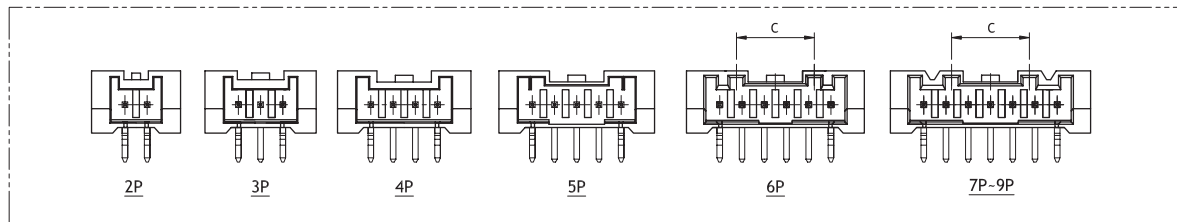

P/N CI10\*\*P\*VK0

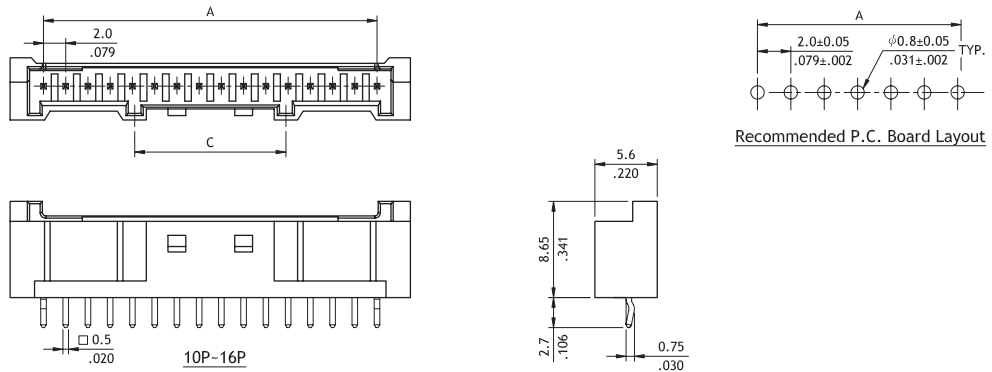

**Ordering Code**

① C I 10    ② 0 2    ③ P    ④ 2    ⑤ H    ⑥ K 0

- ① Series No.
- ② No. of Circuits : 02~16
- ③ Contact type: P = Pin Header

- ④ Plating Code:  
M=Matte Tin over Nickel  
2= Gold flash over Nickel
- ⑤ Type: H = Right Angle  
V = Straight type
- ⑥ Other Option : K0 = With Pin Kinked

**CI10 Series 2.00mm(.079") Wire to Board Connectors DIP & SMT Headers**

- ☉ With locks provide secure mating
- ☉ Insulator: High temperature plastic UL 94V-0 , Color Nature

RoHS Compliant 

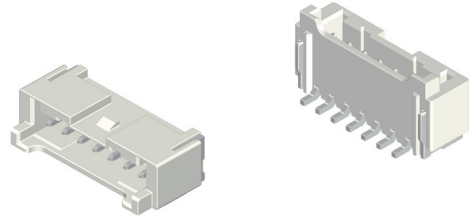

CI

P/N CI10\*\*M1HRA-NH

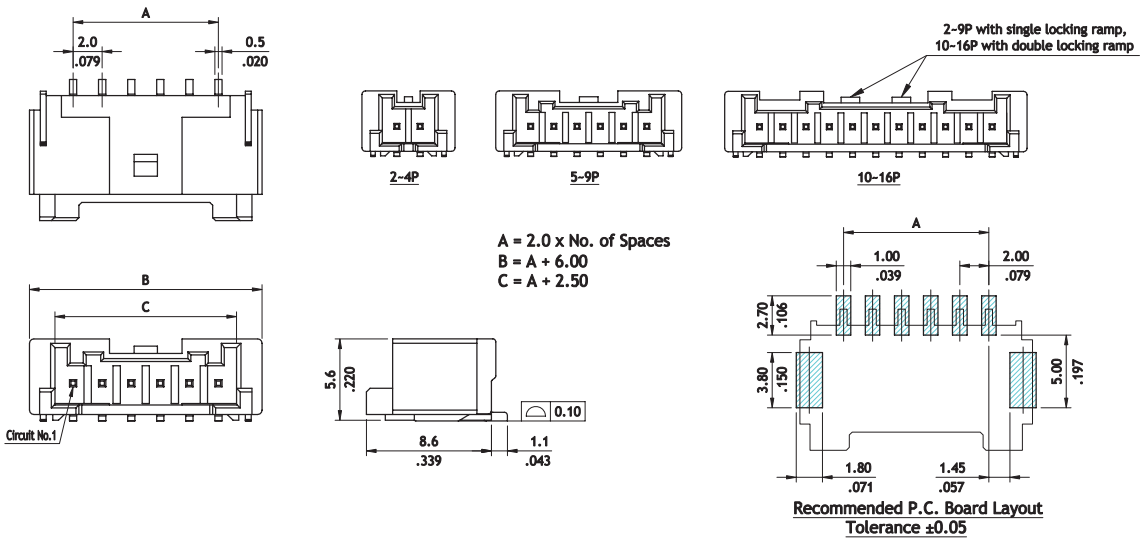

P/N CI10\*\*M1VRA-NH

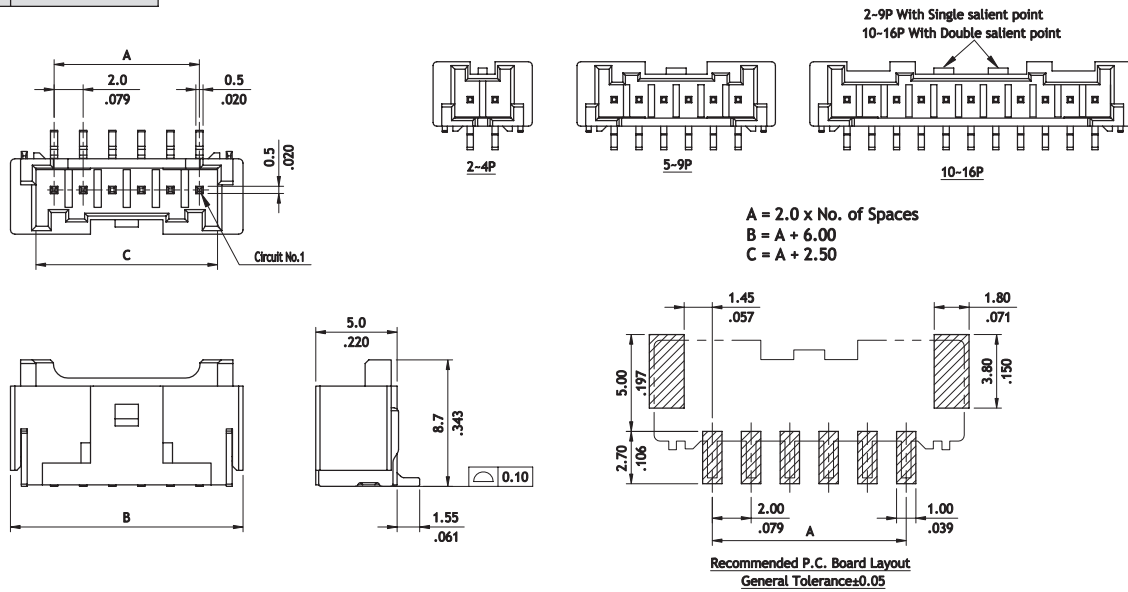

**Ordering Code**

① ② ③ ④ ⑤ ⑥ ⑦ ⑧  
**CI10 02 M 1 H R A - NH**

- ① Series No.
- ② No. of Circuits: 02~06 , 10 , 12 , 15
- ③ Contact type: M = SMT type header
- ④ Plating Code: 1 = Matte Tin over Nickel
- ⑤ Type: H = Right Angle , V = Straight type
- ⑥ Packing Option : R = Tape & Reel
- ⑦ Other Options:A= Without Mylar
- ⑧ NH = For Lead Free soldering process and Halogen-Free

WIRE TO BOARD

**CIDX Series 2.00mm(.079") Single Row Wire to Board Housing & Terminal**

- ⊙ Low profile with locking ribs
- ⊙ Mate with CIDX header
- ⊙ Terminal accommodated AWG#20~#22
- ⊙ Insulator : Glass filled polyester UL 94V-0 , Color Nature
- ⊙ Terminal : Tin plated Phosphor Bronze

**RoHS** Compliant

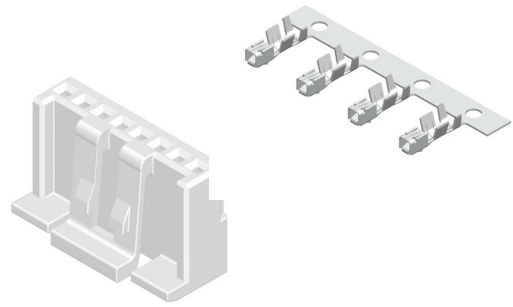

P/N: CIDX\*\*S0010

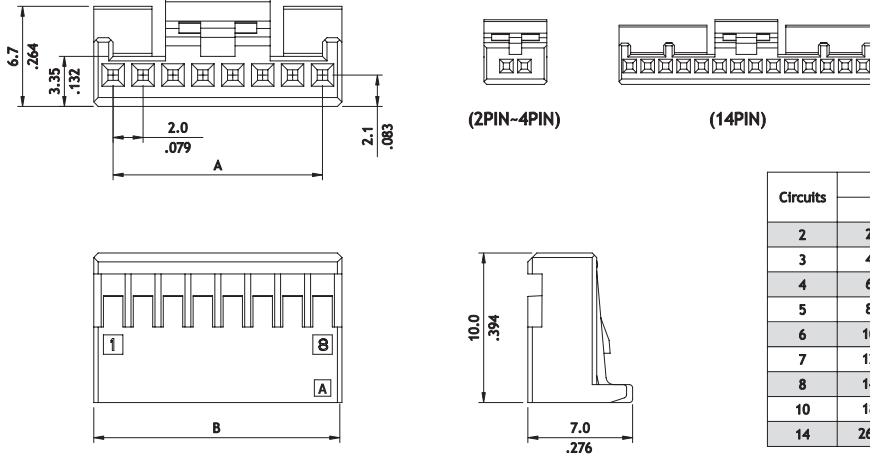

P/N: CIDXT031PP0

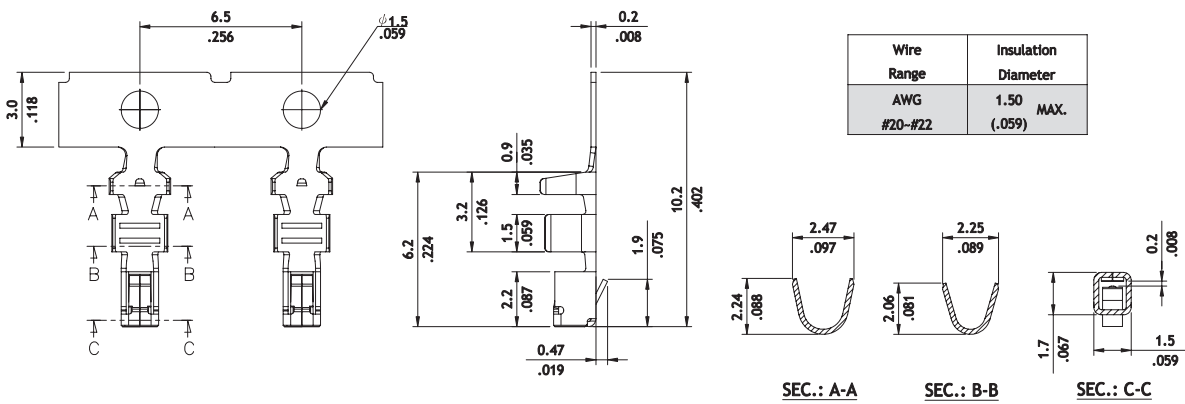

**Ordering Code**

① ② ③ ④  
**C I D X 0 2 S 0 0 1 0**

① ② ③ ④ ⑤  
**C I D X T 0 3 1 P P 0**

- ① Series No.
- ② No. of Circuits: 02~08 , 10 , 14
- ③ S = Housing
- ④ Other Options:  
0010 = Color Black

- ① Series No.
- ② Type: T02 = AWG # 20 ~ # 22
- ③ Plating Code: 1 = Tin over Nickel
- ④ Material: P =Phosphor Bronze
- ⑤ Other Options: P0 = Standard

**CIDX Series 2.00mm(.079") Wire to Board Connectors SMT Headers**

- ⊙ With Locking Slot
- ⊙ Mate with CIDX Housing
- ⊙ Insulator : High temperature plastic UL 94V- 0 , Color Nature
- ⊙ With Tin Plated , Brass

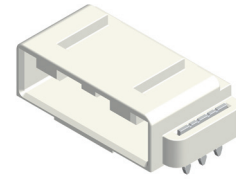

**RoHS** Compliant

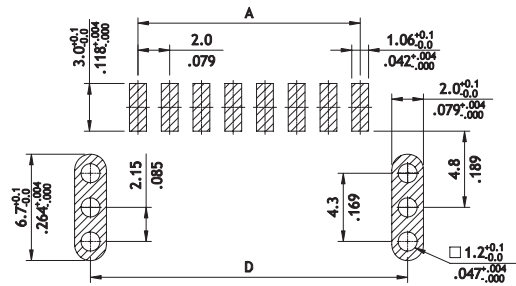
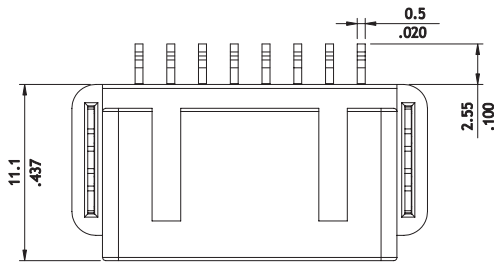

**Recommended P.C. Board Layout**  
General Tolerance ±0.05

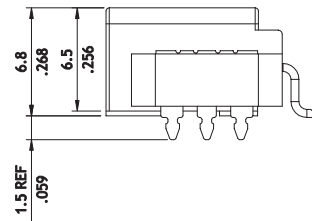
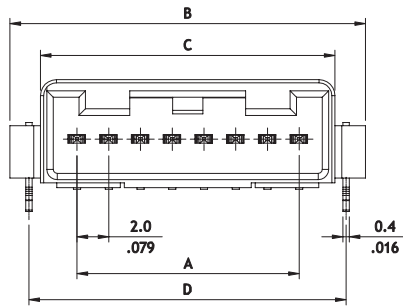

Circuits	Dimension			
	A	B	C	D
2	2.00(.079)	12.90(.508)	9.05(.356)	10.58(.417)
3	4.00(.157)	13.70(.539)	9.85(.388)	11.28(.444)
4	6.00(.236)	14.40(.567)	10.55(.415)	11.98(.472)
5	8.00(.315)	17.80(.701)	13.95(.549)	15.38(.606)
6	10.00(.394)	18.40(.724)	14.55(.573)	15.98(.629)
7	12.00(.472)	21.40(.843)	17.55(.691)	18.98(.747)
8	14.00(.551)	22.40(.882)	18.55(.730)	19.98(.787)
10	18.00(.709)	26.40(1.039)	22.55(.888)	23.98(.944)
14	26.00(1.024)	36.40(1.433)	30.25(1.203)	31.78(1.251)

**Ordering Code**

① ② ③ ④ ⑤ ⑥ ⑦  
**C I D X 02 M 1 H R0 - LF**

- ① Series No.
- ② No. of Circuits: 02~08 , 10 , 14
- ③ Contact type : M = SMT Type
- ④ Plating Code: 1 = Matte Tin over Nickel

- ⑤ Type: H = Right Angle
- ⑥ Other Options: R0 = Reel Packing
- ⑦ LF = For Lead Free IR Reflow Process

**CIDY Series 2.00mm(.079") Single Row Wire to Board Housing & Terminal**

- ⊙ With locking latch provide secure mating
- ⊙ Mate with CIDY header
- ⊙ Can be used CIDY crimp clip terminal
- ⊙ Insulator : Nylon 66 UL 94V-0 , Color Nature
- ⊙ Terminal : Tin plated Phosphor Bronze

RoHS Compliant

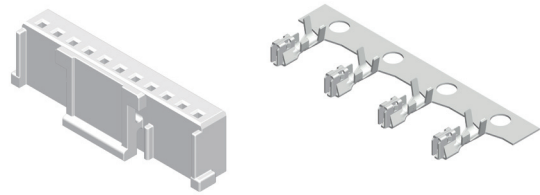

P/N: CIDY\*\*S0000

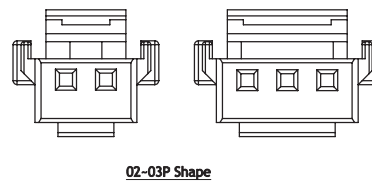
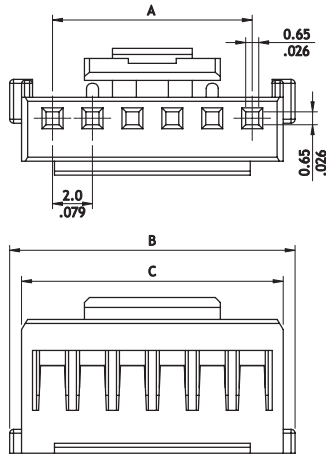

A = No. of Circuits  
 B = A + 5.3  
 C = A + 3.1

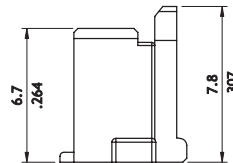

P/N: CIDYT021PP0

Wire Range	Insulation Diameter
AWG #22-#30	1.40(.055) MAX.

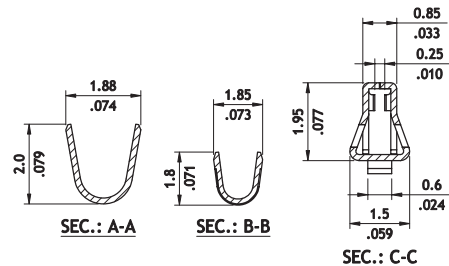
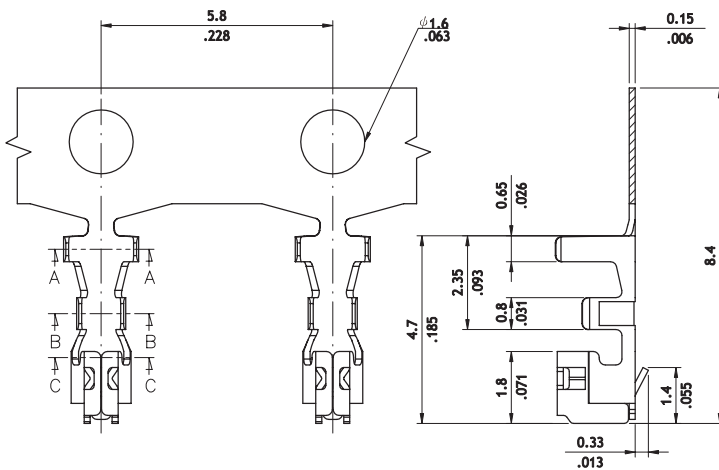

### Ordering Code

①    ②    ③    ④

**CIDY 02 S 0000**

①    ②    ③    ④    ⑤

**CIDY T02 1 P P0**

① Series No.

② No. of Circuits: 02~15

③ S = Housing

④ Other Options: 0000 = Color Nature

① Series No.

② Type: T02 = AWG # 22 ~ # 30

③ Plating Code: 1 = Tin over Nickel

④ Material: P =Phosphor Bronze

⑤ Other Options: P0 = Standard

**CIDY Series 2.00mm(.079") Wire to Board Connectors DIP Headers**

- ⊙ With locking provide secure mating
- ⊙ Mate with CIDY housing
- ⊙ Insulator : Nylon 66 UL 94V-0 , Color Nature
- ⊙ With Tin : plated 0.5 square pin

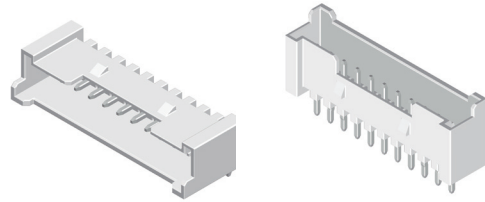

RoHS Compliant

P/N: CIDY\*\*P1VK0

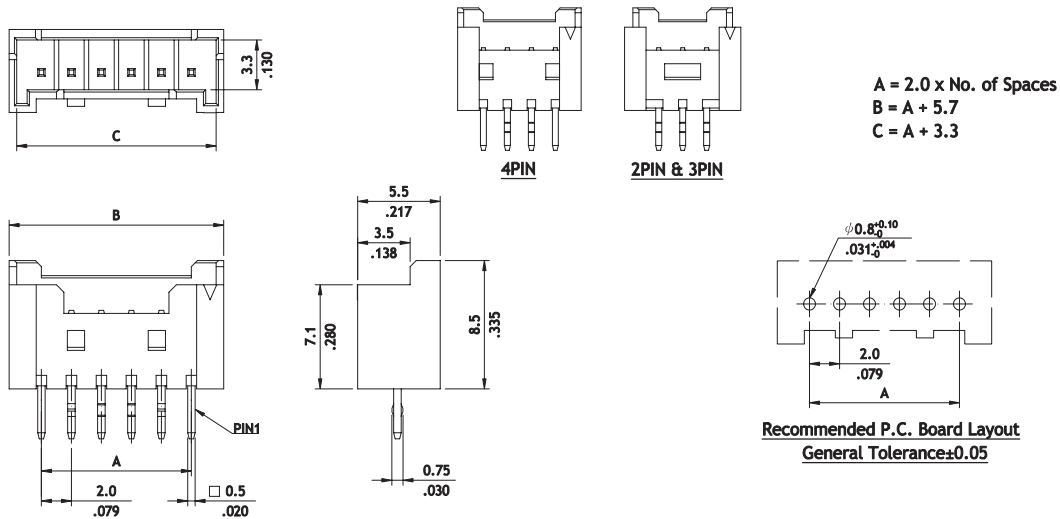

P/N: CIDY\*\*P1H00

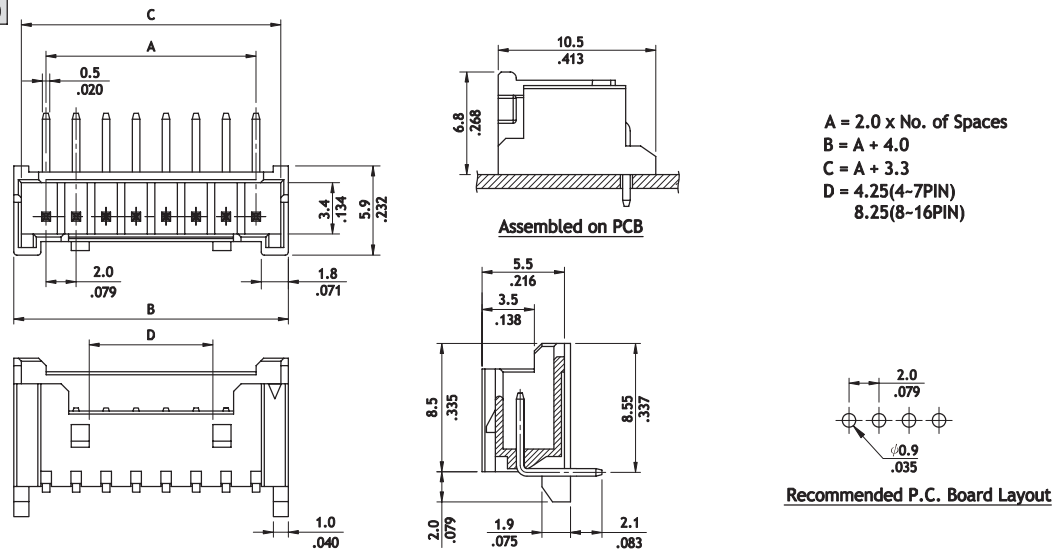

**Ordering Code**

① CIDY ② 15 ③ P ④ 1 ⑤ V ⑥ K0

① CIDY ② 15 ③ P ④ 1 ⑤ H ⑥ 00

- ① Series No.
- ② No. of Circuits: 02~15
- ③ P = Pin Header
- ④ Plating Code : 1 = Tin over Nickel
- ⑤ Type : V = Straight
- ⑥ Other Option : K0 = With pin kinked

- ① Series No.
- ② No. of Circuits: 02~15
- ③ P = Pin Header
- ④ Plating Code : 1 = Tin over Nickel
- ⑤ Type: H = Right angle
- ⑥ Other Option : 00= Standard

**CID9 Series 2.00 mm(.079") Single Row Wire to Board Housing & Terminal**

- ⊙ Mate with CID9 Housing
- ⊙ Can be used with CID9 Crimp Terminal
- ⊙ Insulator : Nylon 66 UL 94V-0 , Color Nature
- ⊙ Tin Plated Phosphor Bronze

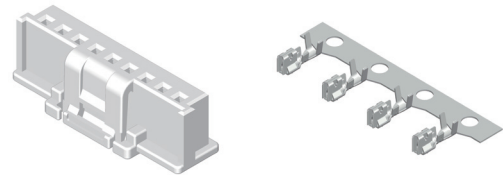

**RoHS** Compliant

P/N: CID9\*\*SL00A

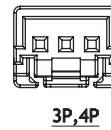
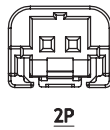
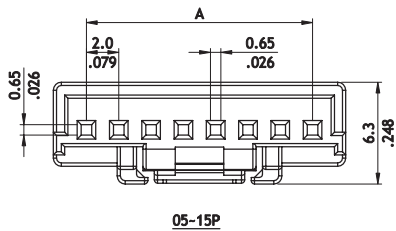

Circuits	Dimension	
	A	
2	2.00 (.079)	8.00
3	4.00 (.157)	8.10
4	6.00 (.236)	10.10
5	8.00 (.315)	12.10
6	10.00 (.394)	14.10
7	12.00 (.472)	16.10
8	14.00 (.551)	18.10
9	16.00 (.630)	20.10
10	18.00 (.709)	22.10
11	20.00 (.787)	24.10
12	22.00 (.866)	26.10
13	24.00 (.945)	28.10
14	26.00 (1.024)	30.10
15	28.00 (1.102)	32.10

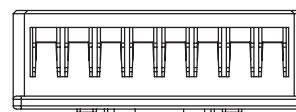
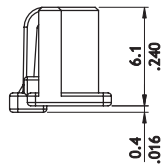
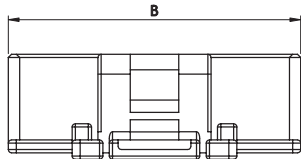

P/N: CID9T0\*1PP0

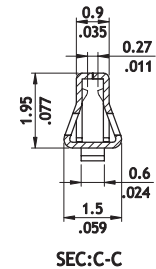
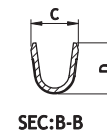
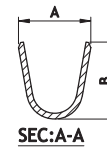
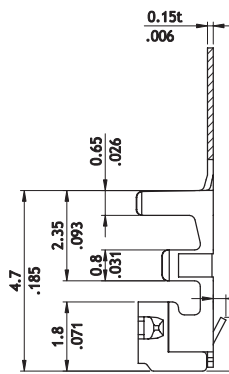
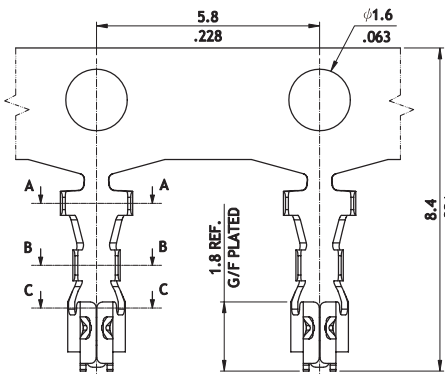

Part No.	Wire Gauge	Dimension				Insulation Range
		A	B	C	D	

**Ordering Code**

① CID9 ② 04 ③ S ④ L ⑤ 00A

① CID9 ② T02 ③ 1 ④ P ⑤ P ⑥ 0

- ① Series No.
- ② No. of Circuits: 02~15
- ③ S = Female
- ④ L = With Locking Latch
- ⑤ Option : 00A = Standard (Color Nature)

- ① Series No.
- ② Type : T02= AWG #20~#22  
T08= AWG#24~#26
- ③ Plating Code: 1 = Tin over Nickel
- ④ Material : P = Phosphor Bronze
- ⑤ Plating method : P = Post Plating
- ⑥ Option : 0 = Standard

**CID9 Series 2.00 mm(.079") Single Row Wire to Board SMT Headers**

- ⊙ Mate with CID9 Housing
- ⊙ Insulator : High temperature plastic UL 94V-0 , Color Nature

RoHS Compliant

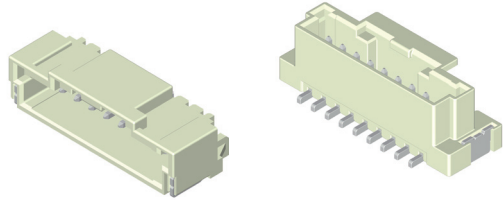

P/N: CID9\*\*M1HR0-LF

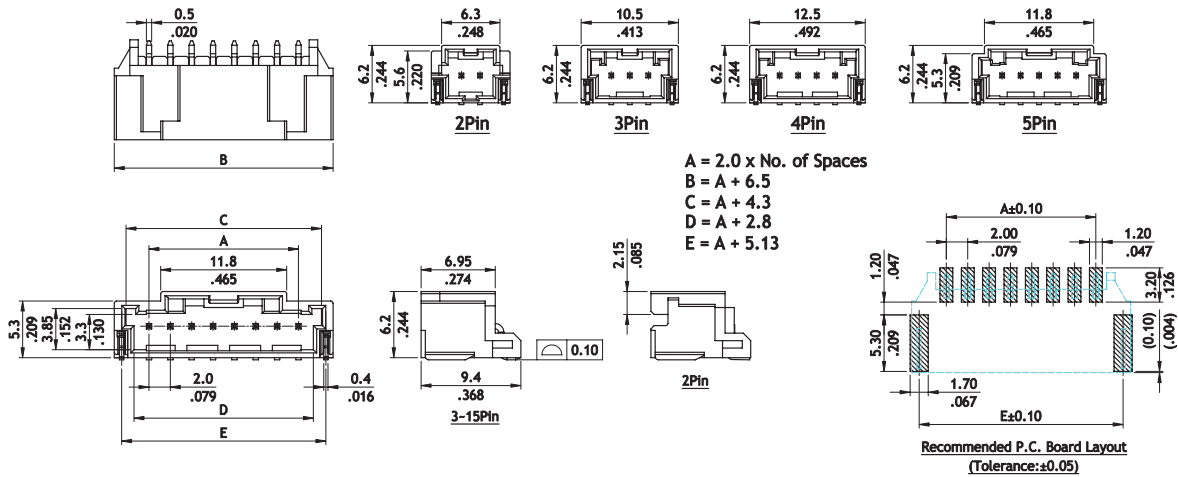

P/N: CID9\*\*M1VR0-LF

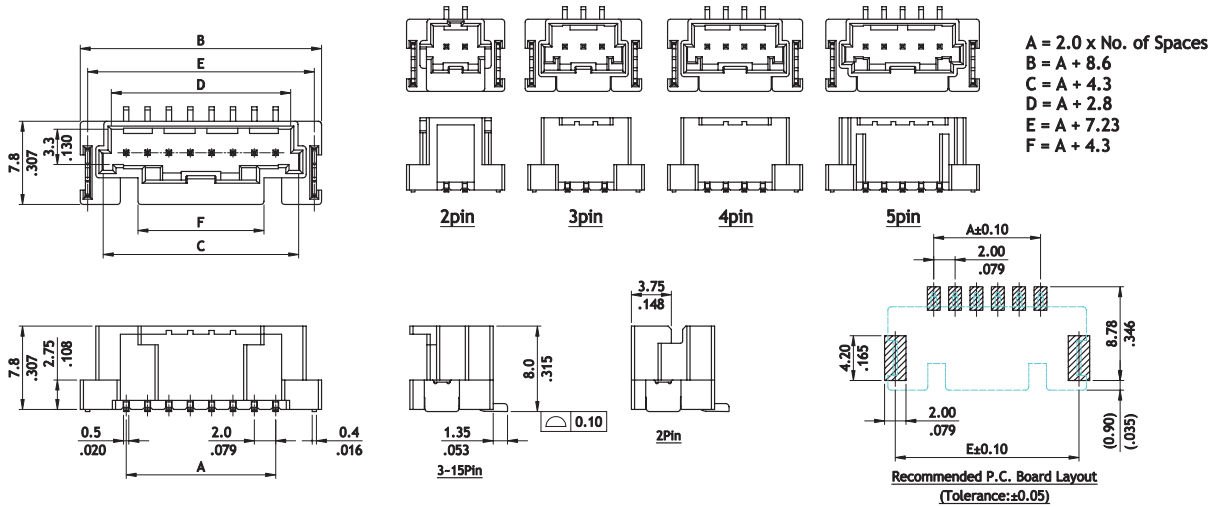

**Ordering Code**

① CID9 ② 02 ③ M ④ 1 ⑤ H ⑥ R0 ⑦ LF

- ① Series No.
- ② No. of Circuits: 02~15
- ③ Contact type: M= SMT Type
- ④ Plating Options:  
1= Tin over Nickel
- ⑤ Tail style: Type : H= Right Angle
- ⑥ Option: R0= Standard
- ⑦ LF = For Lead Free soldering process

① CID9 ② 02 ③ M ④ 1 ⑤ V ⑥ R0 ⑦ LF

- ① Series No.
- ② No. of Circuits: 02~15
- ③ Contact type: M= SMT Type
- ④ Plating Options:  
1= Tin over Nickel
- ⑤ Tail style: Type : V= Staight
- ⑥ Option: R0= Standard
- ⑦ LF = For Lead Free soldering process

**CIEG Series 2.00 mm(.079") Single Row Wire to Wire Housing & Terminal**

- ⊙ Low profile Housing
- ⊙ Insulator : Nylon UL 94 V-0 , Color Nature
- ⊙ Terminal : Tin plated Phosphor Bronze

RoHS Compliant

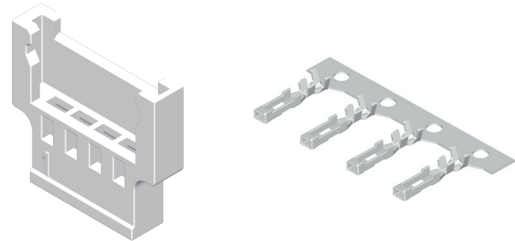

P/N: CIEG\*\*S0000

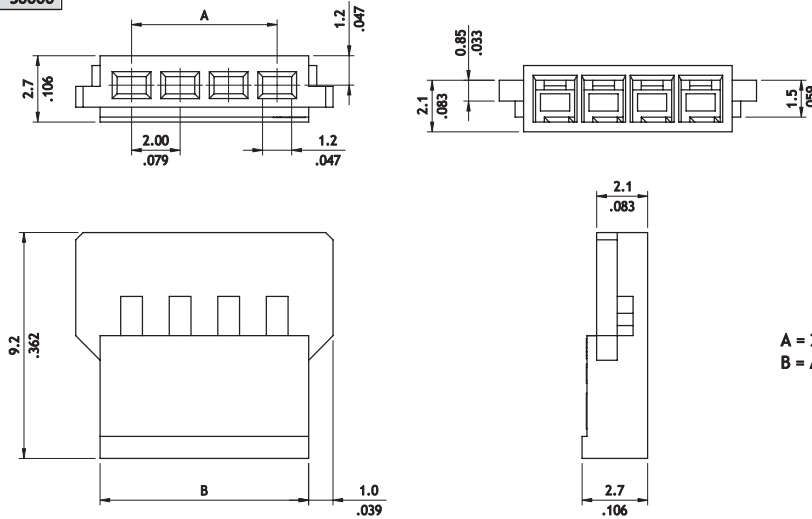

P/N: CIEGT01PPS

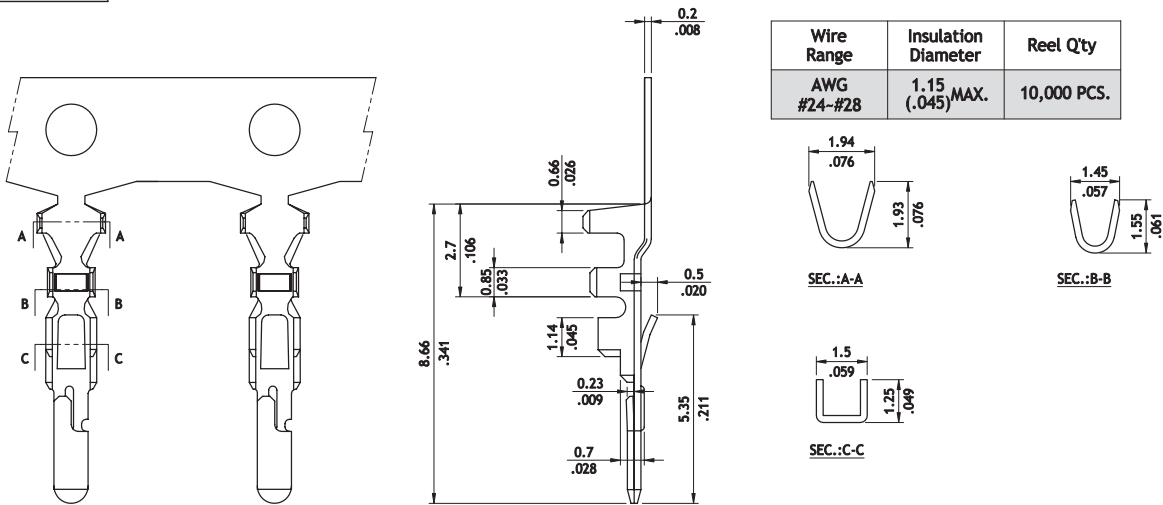

**Ordering Code**

① C I E G    ② 0 4    ③ S    ④ 0 0 0 0

① C I E G    ② T 0 1    ③ 1    ④ P    ⑤ P S

- ① Series No.
- ② No. of Circuits: 02 ~ 11, 13
- ③ S = Receptacle
- ④ Option: 0000 = Standard

- ① Series No.
- ② No. of Circuits:
- ③ Plating Code: 1 = Matte Tin over Nickel
- ④ Material : P = Phosphor Bronze
- ⑤ Option : PS = Receptacle

CI

WIRE TO BOARD

**CIEG Series 2.00 mm(.079") Single Row Wire to Wire Housing & Terminal**

- ⊙ Low profile Housing
- ⊙ Insulator : Nylon UL 94 V-0 , Color Nature
- ⊙ Terminal : Tin plated Phosphor Bronze

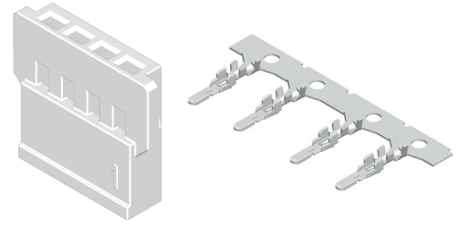

**RoHS** Compliant

P/N: CIEG\*\*P0000

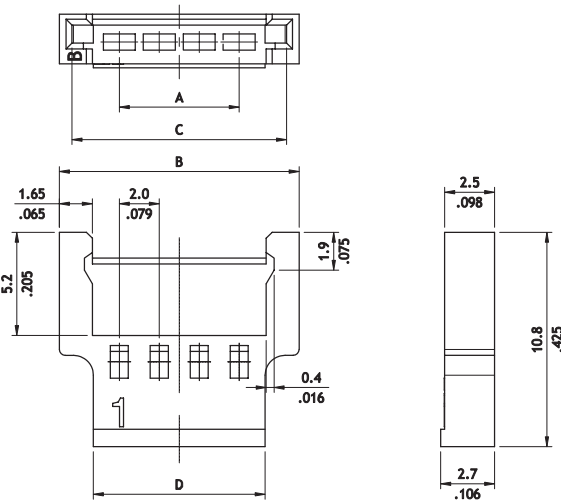

A = 2.0 x No. of Spaces  
 B = A + 6.0  
 C = A + 4.74  
 D = A + 2.6

P/N: CIEGT01PPP

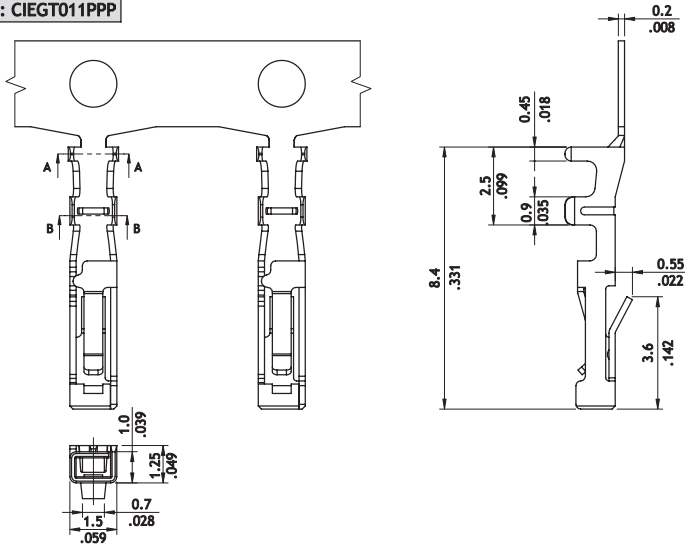

Wire Range	Insulation Diameter	Reel Q'ty
AWG #24-#28	1.15 (.045) MAX.	10,000 PCS.

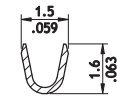
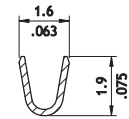

**Ordering Code**

① CIEG ② 04 ③ P ④ 0000

① CIEG ② T01 ③ 1 ④ P ⑤ PP

- ① Series No.
- ② No. of Circuits : 02~11 , 13
- ③ P = Plug
- ④ Color option: 0000 = Standard

- ① Series No.
- ② Type : T01 = AWG #24 ~#28
- ③ Plating Code: 1 = Matte Tin over Nickel
- ④ Material : P = Phosphor Bronze
- ⑤ PP = Plug

**CIE4 Series 2.00 mm(.079") Dual Row Wire to Board DIP Headers**

- ⊙ Mate with CIE4 Housing
- ⊙ With lock latch provide mating
- ⊙ Insulator : High temperature plastic UL 94V-0 , Color Nature

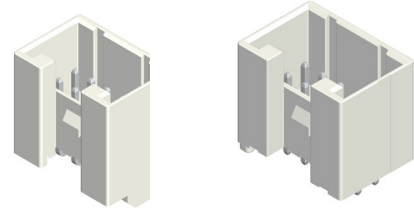

RoHS Compliant

P/N: CIE4\*\*P1VD<sup>0</sup>-LF

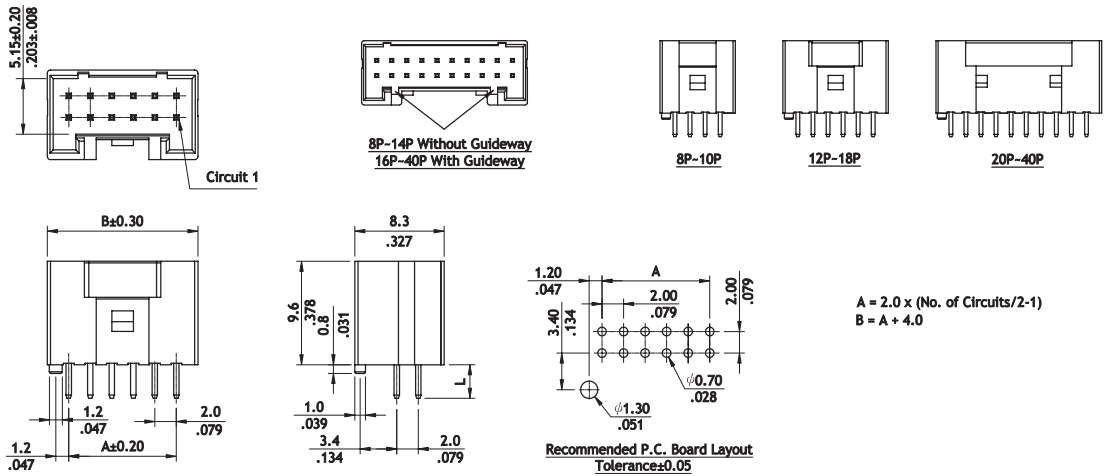

P/N: CIE4\*\*P1HD<sup>0</sup>-LF

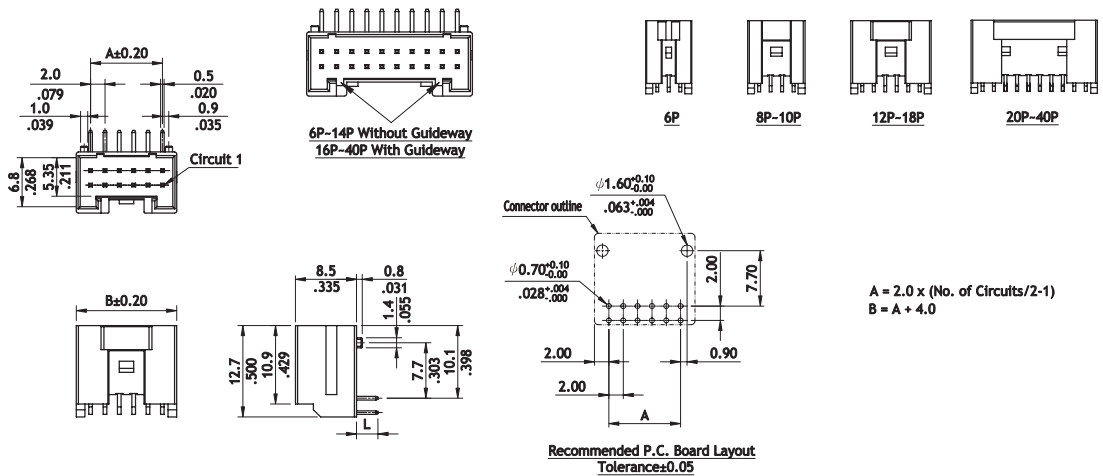

**Ordering Code**

① CIE4 ② 08 ③ P ④ 1 ⑤ VD ⑥ 0 - LF

- ① Series No.
- ② No. of Circuits : 8~40
- ③ Contact type: P = Pin Header
- ④ Plating Options:  
1= Matte Tin over Nickel
- ⑤ Type : V= Straight
- ⑥ Other option: D = Dual Row
- ⑦ Solder tail length : 0 = Dim L: 2.20mm  
1 = Dim L : 3.10mm
- ⑧ LF= For Lead Free Wave Flow Process

① CIE4 ② 08 ③ P ④ 1 ⑤ HD ⑥ 0 - LF

- ① Series No.
- ② No. of Circuits : 6 ~ 40
- ③ Contact type: P = Pin Header
- ④ Plating Options:1= Matte Tin over Nickel
- ⑤ Type : H =Right Angle
- ⑥ Other option: D = Dual Row
- ⑦ Solder tail length : 0 = Dim L: 2.20 mm  
1 = Dim L : 3.10 mm  
2 = Dim L : 3.50 mm
- ⑧ LF= For Lead Free Wave Flow Process

CI

WIRE TO BOARD

**CIE4 Series**

- ⊙ Low profile Housing
- ⊙ Insulator : Nylon UL 94 V-0 , Color Nature
- ⊙ Terminal : Tin plated Phosphor Bronze

RoHS Compliant  

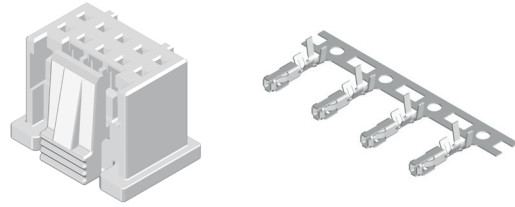

S, P \ B,

P/N CIE4\*SD0\*L

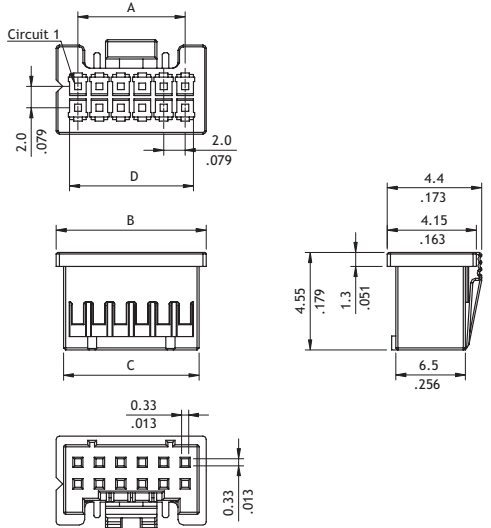

Circuits No.	Dimensions			
	A	B	C	D
06	4.0(.157)	8.00(.315)	6.65(.262)	5.55(.219)
08	6.0(.236)	10.0(.394)	8.65(.341)	7.55(.297)
10	8.0(.315)	12.0(.472)	10.65(.419)	9.55(.376)
12	10.0(.394)	14.0(.551)	12.65(.498)	11.55(.455)
14	12.0(.473)	16.0(.630)	14.65(.577)	13.55(.526)
16	14.0(.551)	18.0(.709)	16.65(.656)	15.55(.612)
18	16.0(.630)	20.0(.787)	18.65(.734)	17.55(.691)
20	18.0(.709)	22.0(.866)	20.65(.813)	19.55(.770)
22	20.0(.787)	24.0(.945)	22.65(.892)	21.55(.848)
24	22.0(.866)	26.0(1.024)	24.65(.801)	23.55(.927)
26	24.0(.945)	28.0(1.102)	26.65(.970)	25.55(1.006)
28	26.0(1.024)	30.0(1.181)	28.65(1.128)	27.55(1.085)
30	28.0(1.102)	32.0(1.260)	30.65(1.207)	29.55(1.163)
32	30.0(1.181)	34.0(1.339)	32.65(1.285)	31.55(1.242)
34	32.0(1.260)	36.0(1.417)	34.65(1.364)	33.55(1.321)
36	34.0(1.339)	38.0(1.500)	36.65(1.443)	35.55(1.400)
38	36.0(1.417)	40.0(1.575)	38.65(1.522)	37.55(1.478)
40	38.0(1.500)	42.0(1.654)	40.65(1.600)	39.55(1.557)

P/N CIE4T021PE0

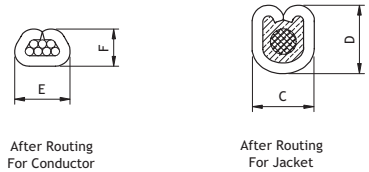
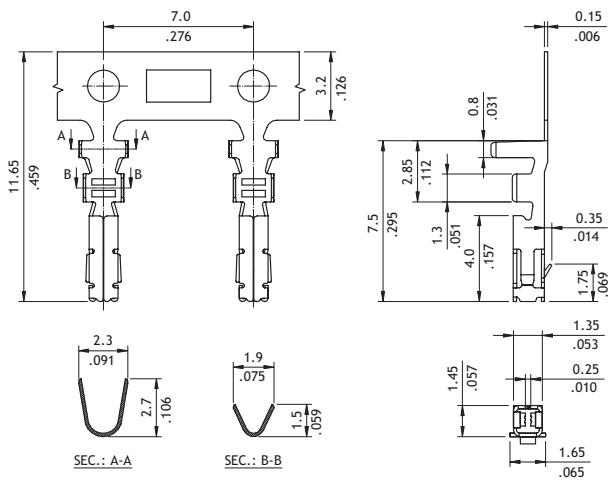

WIRE RANGE	RECOMMENDED CABLE CRIMPING DIMENSION			
	DIM. (mm)			
	C	D	E	F
AWG#22	1.4 MAX	1.4-1.5	1.1-1.2	0.8-0.85
AWG#24	1.4 MAX	1.3-1.4	1.1-1.2	0.75-0.8
AWG#26	1.4 MAX	1.2-1.3	1.1-1.2	0.7-0.75
AWG#28	1.4 MAX	1.1-1.2	1.1-1.2	0.65-0.7

**Ordering Code**

① C ② IE4 ③ 08 ④ S ⑤ D ⑥ 01 L

① CIE4 ② T02 ③ 1 ④ P ⑤ E ⑥ 0

- ① Series No.
- ② No. of Circuits : 8~40
- ③ Contact type: S = Housing
- ④ Other Options:  
D= Dual row type
- ⑤ Color Option : 01 = Black , 03 = Red , 06 = Green  
07 = Blue
- ⑥ Other option: L = Locking Latch(Standard)

- ① Series No.
- ② Type : T02 = AWG #22~ #28
- ③ Plating : 1 = Bright Tin Plated over Nickel
- ④ Material : P = Phosphor Bronze
- ⑤ Plating method : E = Pre-tinned
- ⑥ Other : 0 = Standard

**CIEP Series 2.50mm (.098") Wire to Board Connectors Housing & Terminal**

- ⊙ Low profile Housing
- ⊙ Insulator : Nylon UL 94 V-0 , Color Nature
- ⊙ Terminal : Tin plated Phosphor Bronze

RoHS Compliant

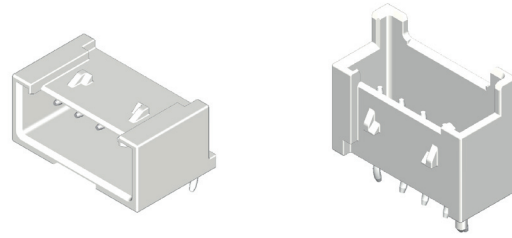

**P/N CIEP\*\*P1VKP-NH**

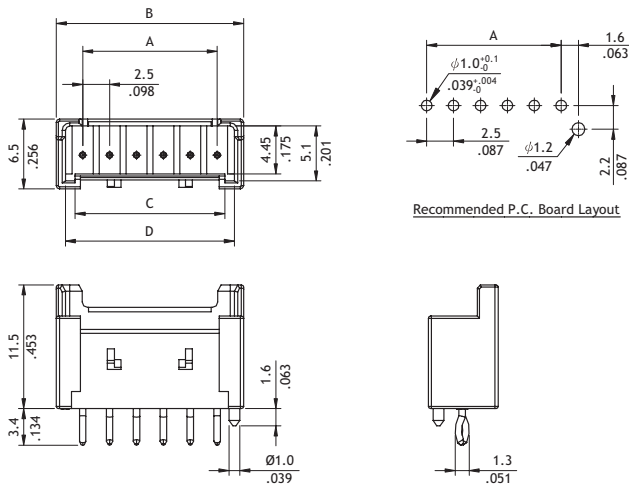

Circuits	Dimension			
	A	B	C	D
2	2.5(.098)	7.4(.291)	3.9(.154)	5.7(.224)
3	5.0(.197)	9.9(.390)	6.4(.252)	8.2(.323)
4	7.5(.295)	12.4(.488)	8.9(.350)	10.7(.421)
5	10.0(.393)	14.9(.587)	11.4(.449)	13.20(.520)
6	12.5(.492)	17.4(.685)	13.9(.547)	15.7(.618)
7	15.0(.591)	19.9(.783)	16.4(.646)	18.2(.717)
8	17.5(.689)	22.4(.882)	18.9(.744)	20.7(.815)
9	20.0(.787)	24.9(.980)	21.4(.843)	23.2(.913)
10	22.5(.886)	27.4(1.079)	23.9(.941)	25.7(1.012)
11	25.0(.984)	29.9(1.177)	26.4(1.039)	28.2(1.110)
12	27.5(1.083)	32.4(1.276)	28.9(1.138)	30.7(1.209)
13	30.0(1.181)	34.9(1.374)	31.4(1.236)	33.2(1.307)
14	32.5(1.280)	37.4(1.472)	33.9(1.335)	35.7(1.406)
15	35.0(1.378)	39.9(1.571)	36.4(1.433)	38.2(1.504)

**P/N CIEP\*\*P1HK0-NH**

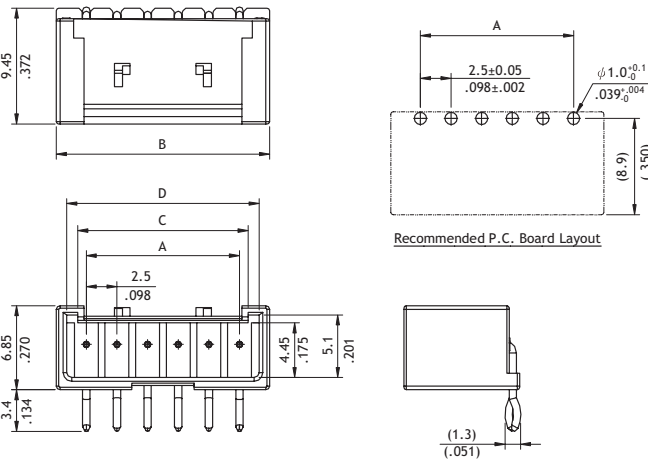

**Ordering Code**

① CIEP ② 02 ③ P ④ 1 ⑤ H ⑥ K0 - ⑦ NH

- ① Series No.
- ② No. of Circuits: 02~15
- ③ Contact type : P = Pin Header
- ④ Plating Code: 1 = Tin over Nickel

- ⑤ Tail Type: V = Straight Type  
H = Right Angle
- ⑥ Other Options: K0 = With Pin Kinked , Without Peg  
KP = With Pin Kinked & Peg
- ⑦ NH = For Lead Free soldering process and Halogen-Free

**CIEP Series 2.5mm (.098") Wire to Board Connector Housing & Terminal**

- ⊙ Low profile Housing
- ⊙ Insulator : Nylon UL 94 V-0 , Color Nature
- ⊙ Terminal : Tin plated Phosphor Bronze

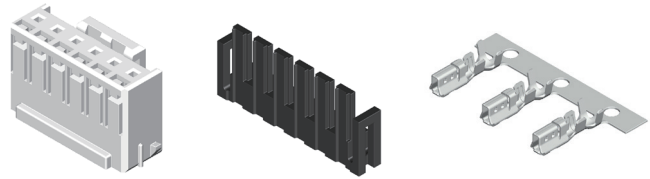

RoHS Compliant

CI

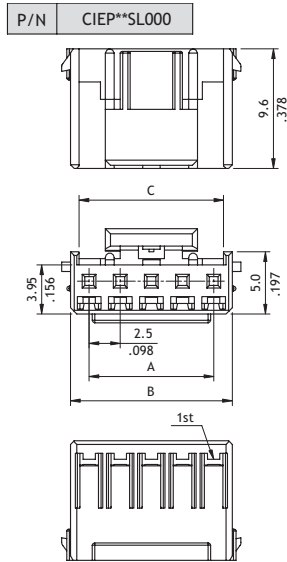

Circuits	Dimension		
	A	B	C
2	2.5(.098)	5.5(.217)	4.1(.161)
3	5.0(.197)	8.0(.315)	6.6(.260)
4	7.5(.295)	10.5(.413)	9.1(.385)
5	10.0(.394)	13.0(.512)	11.6(.457)
6	12.5(.492)	15.5(.610)	14.1(.555)
7	15.0(.591)	18.0(.709)	16.6(.654)
8	17.5(.689)	20.5(.807)	19.1(.752)
9	20.0(.787)	23.0(.906)	21.6(.850)
10	22.5(.886)	25.5(1.004)	24.1(.949)
11	25.0(.984)	28.0(1.102)	26.6(1.047)
12	27.5(1.083)	30.5(1.201)	29.1(1.146)
13	30.0(1.181)	33.0(1.299)	31.6(1.244)
14	32.5(1.280)	35.5(1.398)	34.1(1.343)
15	35.0(1.378)	38.0(1.496)	36.6(1.441)

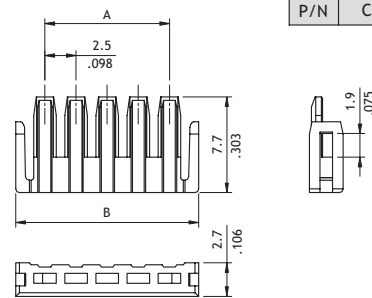

Circuits	Dimension		Circuits	Dimension	
	A	B		A	B
2	2.5(.098)	7.2(.283)	9	20.0(.787)	24.7(.972)
3	5.0(.197)	9.7(.382)	10	22.5(.886)	27.2(1.071)
4	7.5(.295)	12.2(.480)	11	25.0(.984)	29.7(1.169)
5	10.0(.394)	14.7(.579)	12	27.5(1.083)	32.2(1.268)
6	12.5(.492)	17.2(.677)	13	30.0(1.181)	34.7(1.366)
7	15.0(.591)	19.7(.776)	14	32.5(1.280)	37.2(1.465)
8	17.5(.689)	22.2(.874)	15	35.0(1.378)	39.7(1.563)

P/N CIEPT\*\*1PP0

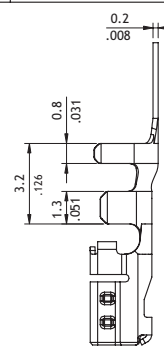
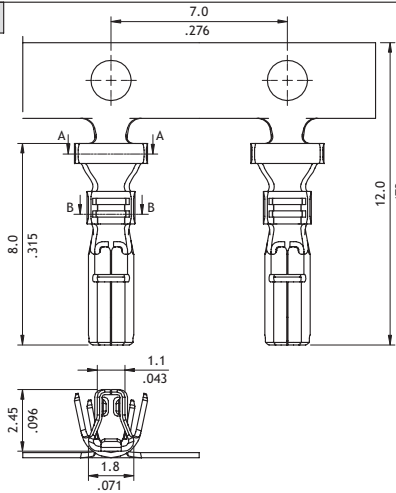

Part No.	Wire Range	Insulation Diameter	Reel Qty
CIEPT031PP0	AWG #20-#22	1.5-1.8 (.059-.071)	10,000 PCS
CIEPT021PP0	AWG #24-#26	1.28-1.42 (.05-.056)	10,000 PCS

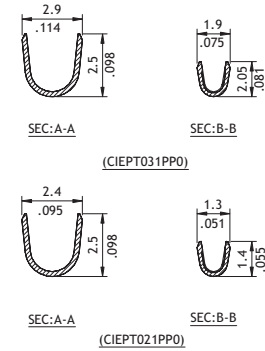

**Ordering Code**

① ② ③ ④ ⑤      ① ② ③ ④ ⑤ ⑥      ① ② ③ ④  
**C I E P 0 8 S L 0 0 0      C I E P T 0 2 1 P E 0      C I E P 0 8 C 0 0 1 0**

- ① Series No.
- ② No. of Circuits : 1~15
- ③ S = Female
- ④ L = With Locking Latch
- ⑤ Option : 000 =Standard

- ① Series No.
- ② Type : T03 = AWG #20 ~ #22  
T02 = AWG #24 ~ #26
- ③ Plating : 1 = Tin Plated over Nickel
- ④ Material : P = Phosphor Bronze
- ⑤ Plating method : P = Post Plating
- ⑥ Other : 0 = Standard

- ① Series No.
- ② Contact : 02 ~15
- ③ C = TPA
- ④ Option : 0010 =Standard

WIRE TO BOARD

**CIEW Series 2.00mm (.079") Dual Row Wire to Board Connectors DIP Headers**

- ⊙ Low profile Housing
- ⊙ Insulator : Nylon UL 94 V-0 , Color Nature
- ⊙ Terminal : Tin plated Phosphor Bronze

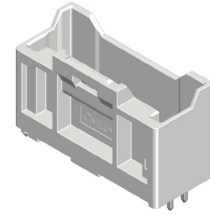

RoHS Compliant

P/N CIEW\*\*P1VD\*-NH

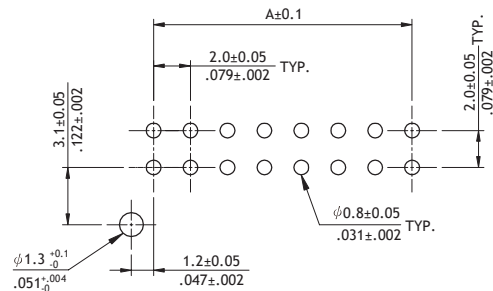
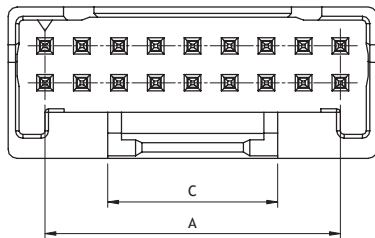

Recommended P.C.B board Layout

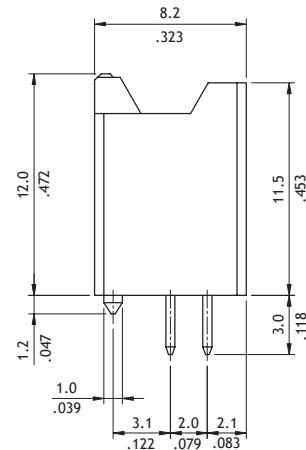
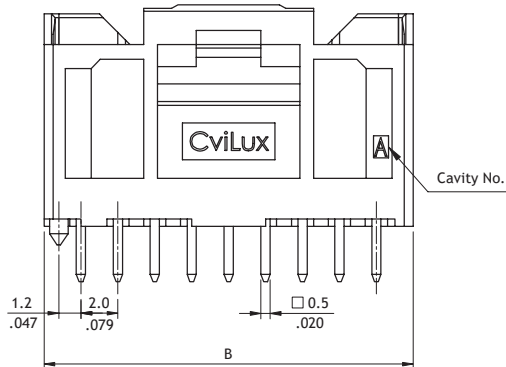

**Ordering Code**

① CIEW ② 04 ③ P ④ 1 ⑤ V ⑥ D ⑦ 0 - ⑧ NH

- ① Series No.
- ② No. of Circuits:
- ③ Contact Type : P = Pin Header
- ④ Plating Code:  
1= Tin over Nickel

- ⑤ Type: V = Straight
- ⑥ Row Option : D = Dual Row
- ⑦ Other Options:  
L = LCP +30% G.F ,Color Nature  
0 = Nylon 10T+30% G.F ,Color Nature
- ⑧ NH = For Lead Free IR process and Halogen-Free

**CIEW Series 2.00mm (.079") Dual Row Wire to Housing & Terminal**

- ⊙ Low profile Housing
- ⊙ Insulator : Nylon UL 94 V-0 , Color Nature
- ⊙ Terminal : Tin plated Phosphor Bronze

RoHS Compliant  

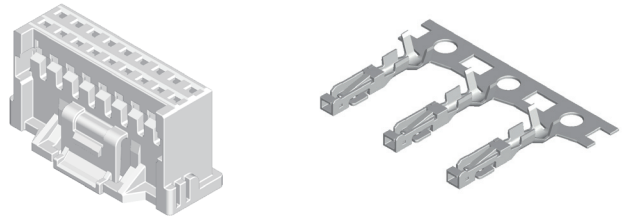

P/N CIEW\*\*S0000

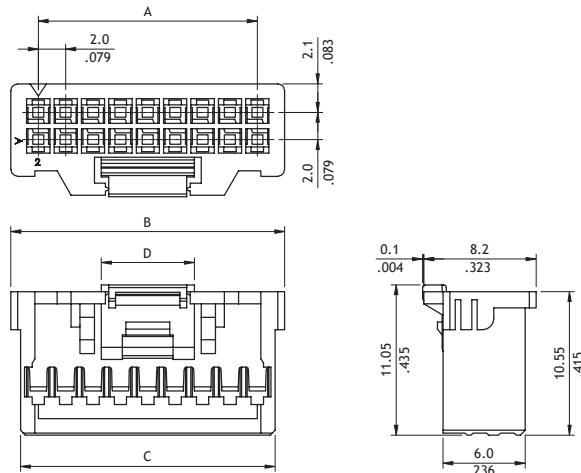

Dim.A= (Circuit/2-1)x 2.00  
 Dim.B= Dim.A+ 4.00  
 Dim.C= Dim.A+ 2.60  
 Dim.D= 10PIN: 5.1  
 12-34PIN: 6.8  
 \*Available in 10-34c circuits

P/N CIEWT\*\*1PP0

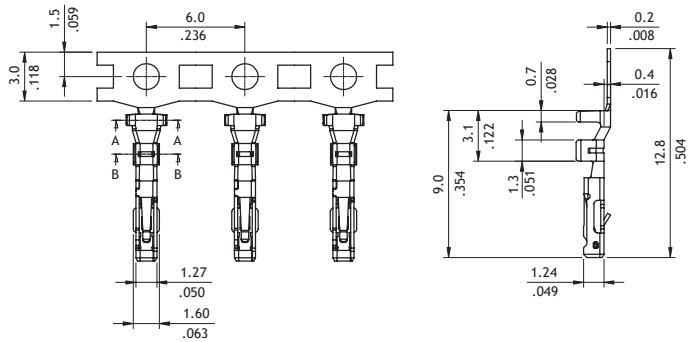

Part No.	Wire Range	Insulation Diameter	Reel Qty
CIEWT021PP0	AWG #26- #28	φ 0.85- Ø1.4mm	15,000
CIEWT031PP0	AWG #22- #24	φ 0.95- Ø1.5mm	15,000

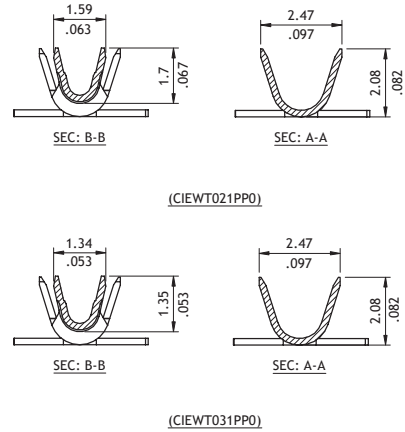

**Ordering Code**

① ② ③ ④  
**C I E W 0 4 S 0 0 0 0**

- ① Series No.
- ② No. of Circuits:
- ③ S = Housing
- ④ Other Options: 0000 = Standard  
 \*Special options consult manufacturer

① ② ③ ④ ⑤ ⑥  
**C I E W T 0 2 1 P P 0**

- ① Series No.
- ② Type: 02 = AWG #26 ~ #28  
 03 = AWG #22 ~ #24
- ③ Plating Code: 1 = Tin over Nickel
- ④ Material: P = Phosphor Bronze
- ⑤ Plating method : P = Post Plating
- ⑥ Option : 0 = Standard

**CI21 Series 2.5mm(.098") Wire to Board Connectors Housing & Terminal**

- ⊙ Low profile with locking ribs
- ⊙ Mate with CI21 header
- ⊙ Can be used with CI21 crimp clip terminal
- ⊙ Insulator: Nylon 66 UL 94V-0 , Color Nature
- ⊙ Terminal: Tin plated Phosphor Bronze

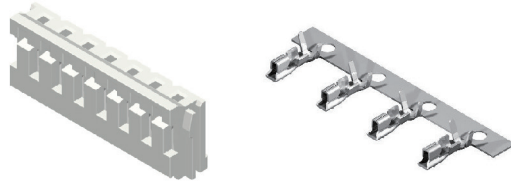

RoHS Compliant

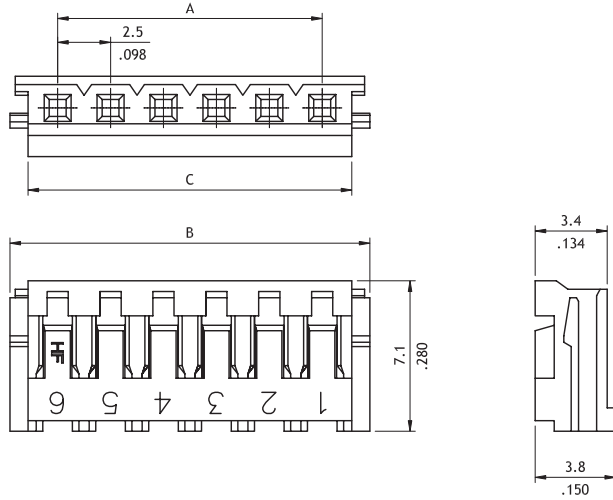

Circuits	Dimension		
	A	B	C
2	2.5(.098)	7.0(.276)	5.4(.213)
3	5.0(.197)	9.5(.374)	7.9(.311)
4	7.5(.295)	12.0(.472)	10.4(.409)
5	10.0(.394)	14.5(.571)	12.9(.508)
6	12.5(.492)	17.0(.669)	15.4(.606)
7	15.0(.591)	19.5(.768)	17.9(.705)
8	17.5(.689)	22.0(.866)	20.4(.803)
9	20.0(.787)	24.5(.965)	22.9(.902)
10	22.5(.886)	27.0(1.063)	25.4(1.000)
11	25.0(.984)	29.5(1.161)	27.9(1.098)
12	27.5(1.083)	32.0(1.260)	30.4(1.197)
13	30.0(1.181)	34.5(1.358)	32.9(1.295)
14	32.5(1.280)	37.0(1.457)	35.4(1.394)
15	35.0(1.378)	39.5(1.555)	37.9(1.492)

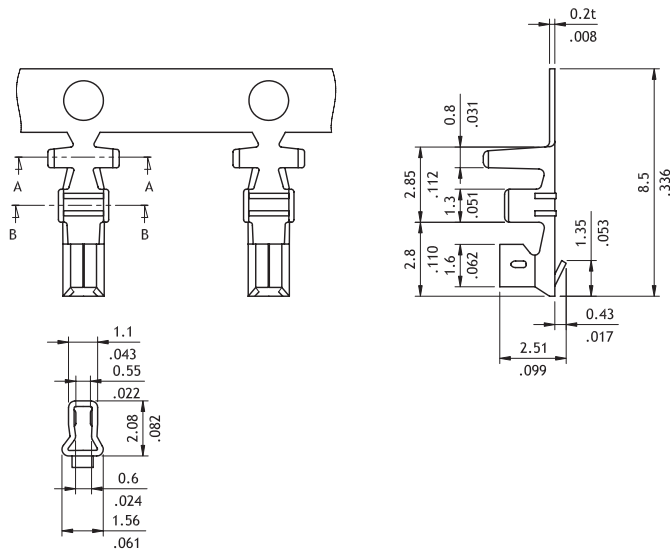

Wire Range	Insulation Diameter	Reel Qty
AWG #24-#30	1.9 MAX. (.075)	10,000 PCS.

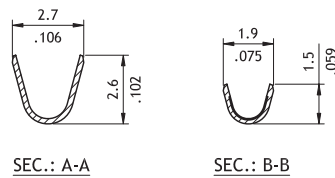

**Ordering Code**

① C ② I ③ 21 ④ 15 ⑤ S ⑥ 0000

① C ② I ③ 21 ④ T02 ⑤ 1 ⑥ P ⑦ E0

- ① Series No.
- ② No. of Circuits: 02 ~15
- ③ S = Housing
- ④ Other Options: 0000 = Standard  
\*Special options consult manufacturer

- ① Series No.
- ② Type: T02 = AWG #24 ~ #30
- ③ Plating Code: 1 = Tin over Nickel
- ④ Material: P = Phosphor Bronze
- ⑤ Other Options: E0 = Standard

**CI21 Series 2.50mm(.098") Wire to Board Connectors DIP Headers**

- ⊙ With locking slots and Pin kinked
- ⊙ Mate with CI21 Housing
- ⊙ Insulator: High temperature plastic UL 94V-0, Color Nature
- ⊙ With Tin plated 0.64mm square pin

RoHS Compliant 

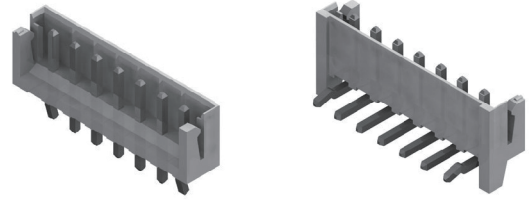

**Straight Type**

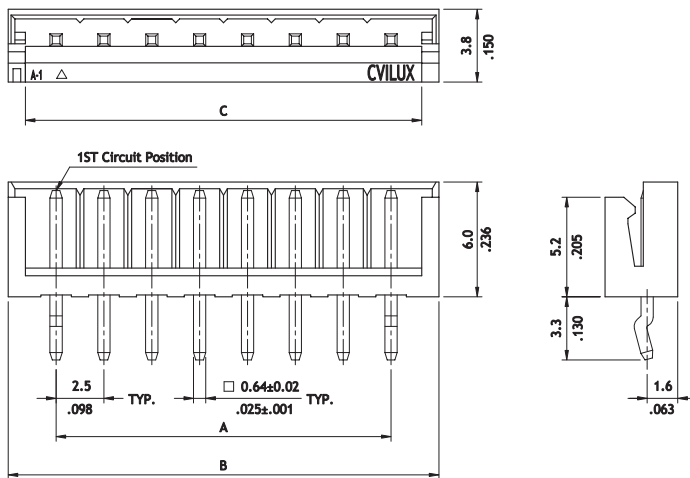

Circuits	Dimension		
	A	B	C
2	2.5(.098)	7.5(.295)	5.7(.224)
3	5.0(.197)	10.0(.394)	8.2(.323)
4	7.5(.295)	12.5(.492)	10.7(.421)
5	10.0(.394)	15.0(.591)	13.2(.520)
6	12.5(.492)	17.5(.689)	15.7(.618)
7	15.0(.591)	20.0(.787)	18.2(.717)
8	17.5(.689)	22.5(.886)	20.7(.815)
9	20.0(.787)	25.0(.984)	23.2(.913)
10	22.5(.886)	27.5(1.083)	25.7(1.012)
11	25.0(.984)	30.0(1.181)	28.2(1.110)
12	27.5(1.083)	32.5(1.280)	30.7(1.209)
13	30.0(1.181)	35.0(1.378)	33.2(1.307)
14	32.5(1.280)	37.5(1.476)	35.7(1.406)
15	35.0(1.378)	40.0(1.575)	38.2(1.504)

**Right angle Type**

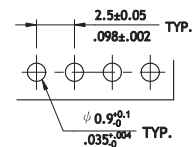
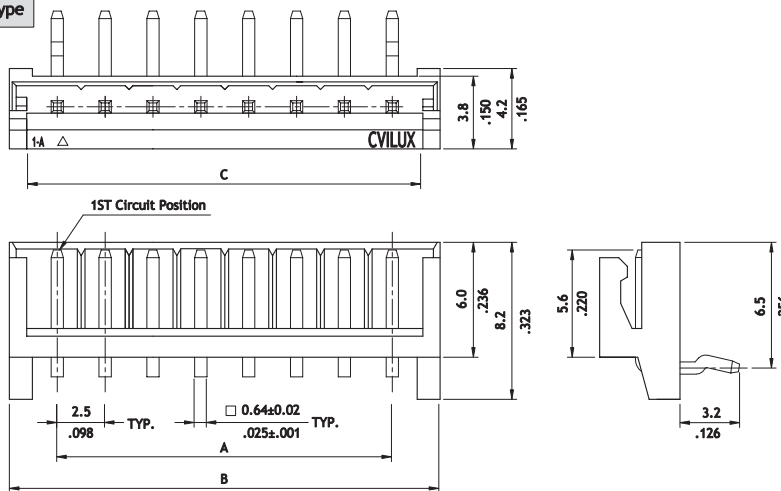

**Recommended P.C. Board Layout**

**Ordering Code**

① ② ③ ④ ⑤ ⑥ ⑦  
**C I 21 15 P 1 V K 0 - N H**

- ① Series No.
- ② No. of Circuits: 02 ~ 15
- ③ P = DIP Type
- ④ Plating Code: 1 = Matte Tin over Nickel
- ⑤ Type: V = Straight  
H = Right Angle
- ⑥ Other Options: 00 = Without Pin Kinked  
K0 = With Pin Kinked (Standard)
- ⑦ NH = For Lead Free soldering process and Halogen-Free  
\*Special options consult manufacturer

**CI22 Series 2.50mm(.098") Wire to Board Connectors Housing & Terminal**

- ⊙ Low profile with locking ribs
- ⊙ Mate with CI22 Header
- ⊙ Can be used with CI22 crimp clip terminal
- ⊙ Insulator: Nylon 66 UL 94V-0, Color Nature
- ⊙ Terminal: Tin plated Brass or Phosphor Bronze

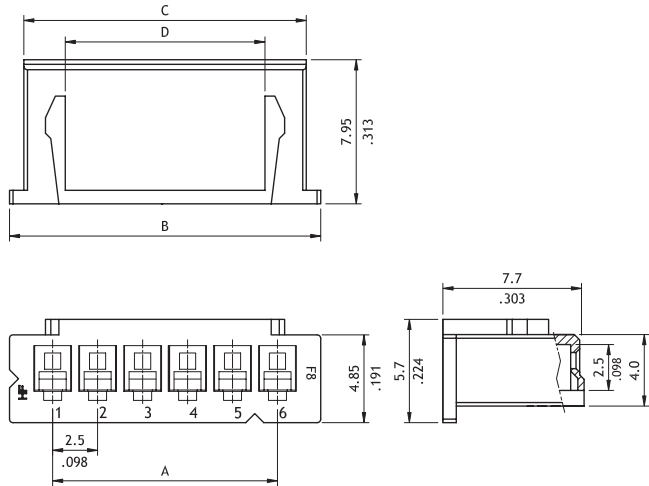
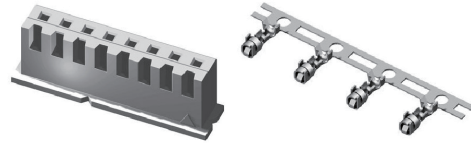

Circuits	Dimension			
	A	B	C	D
2	2.5(.098)	7.3(.287)	5.7(.224)	1.0(.039)
3	5.0(.197)	9.8(.386)	8.2(.323)	3.5(.138)
4	7.5(.295)	12.3(.484)	10.7(.421)	6.0(.236)
5	10.0(.394)	14.8(.583)	13.2(.520)	8.5(.335)
6	12.5(.492)	17.3(.681)	15.7(.618)	11.0(.433)
7	15.0(.591)	19.8(.780)	18.2(.717)	13.5(.531)
8	17.5(.689)	22.3(.878)	20.7(.815)	16.0(.630)
9	20.0(.787)	24.8(.976)	23.2(.913)	18.5(.728)
10	22.5(.886)	27.3(1.075)	25.7(1.012)	21.0(.827)
11	25.0(.984)	29.8(1.173)	28.2(1.110)	23.5(.925)
12	27.5(1.083)	32.3(1.272)	30.7(1.209)	26.0(1.024)
13	30.0(1.181)	34.8(1.370)	33.2(1.307)	28.5(1.122)
14	32.5(1.280)	37.3(1.469)	35.7(1.406)	31.0(1.220)
15	35.0(1.378)	39.8(1.567)	38.2(1.504)	33.5(1.319)
16	37.5(1.476)	42.3(1.665)	40.7(1.602)	36.0(1.417)

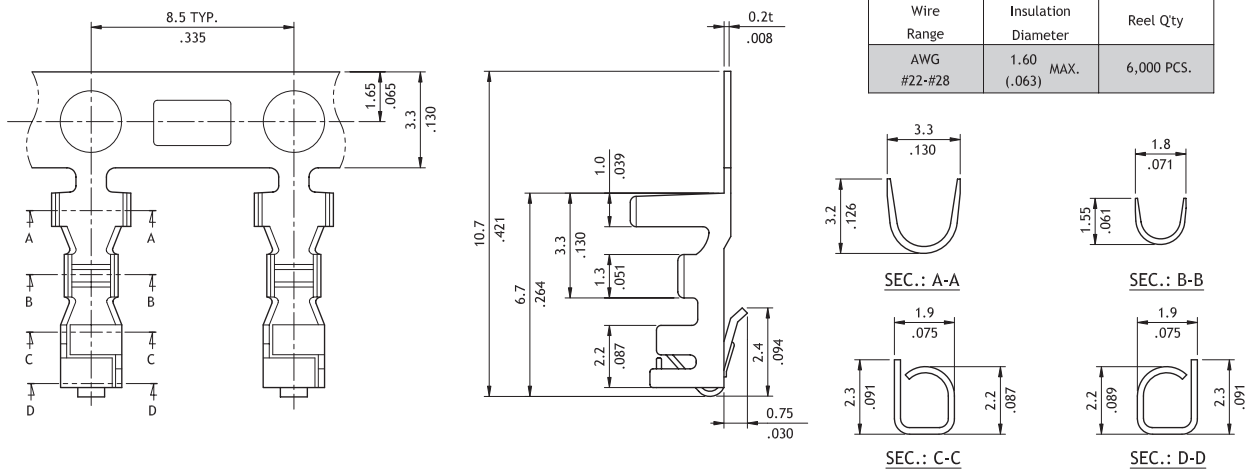

**Ordering Code**

① C I 22 ② 1 5 ③ S ④ 0000

- ① Series No.
- ② No. of Circuits: 02 ~ 16
- ③ S = Housing
- ④ Other Options: 0000 = Standard

① C I 2 2 ② T 0 2 ③ 1 ④ P ⑤ E 0

- ① Series No.
- ② Type : T02 = AWG #22~#28
- ③ Plating: 1= Tin over Nickel
- ④ Material : P=Phosphor Bronze  
B=Brass
- ⑤ Other options: E0=Standard

CI

WIRE TO BOARD

**CI22 Series 2.50mm(.098") Wire to Board IDC Connectors Housing & IDC Cable**

- ⊙ Low profile with locking ribs
- ⊙ Mate with CI22 Header
- ⊙ Insulator: Nylon 66 UL 94V-0, Color Nature
- ⊙ Terminal: Tin plated Phosphor Bronze

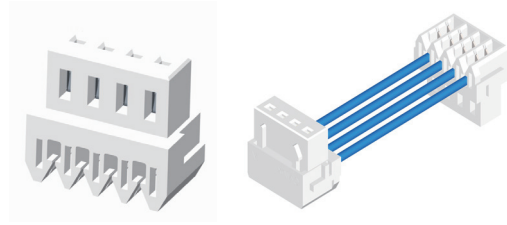

CI

P/N CI22\*\*S1000-NH

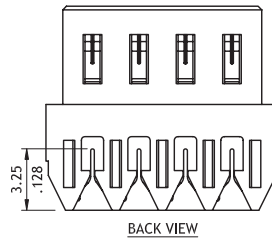
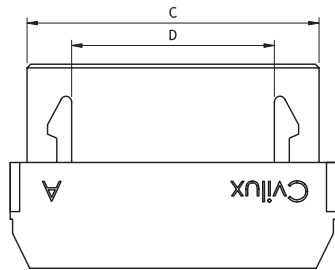

Wire Range	Insulation Diameter
AWG #24,#28	1.5 (.059) MAX.

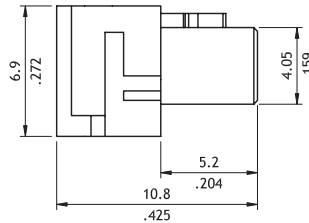
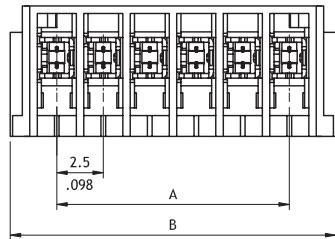

A = 2.5 x No. of Spaces  
 B = A + 2.5  
 C = A + 3.2  
 D = A · 1.6

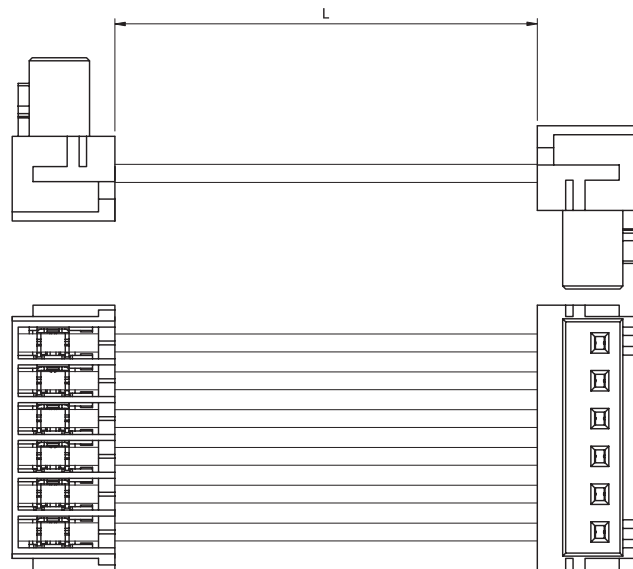

**Ordering Code**

① C ② 122 ③ 15 ④ S ⑤ 1 ⑥ 00 - ⑦ NH

- ① Series No.
- ② No. of Circuits: 02 ~ 15
- ③ S = Housing
- ④ Plating Code:  
1 = Matte Tin over Nickel
- ⑤ 0 = For AWG 28 , 1 = For AWG 24
- ⑥ Other Options: 00 = Standard
- ⑦ NH = For Lead Free and Halogen-Free

① QH-I22 ② 06 ③ 0100 ④ 00 ⑤ 0

- ① Series No.
- ② No. of Circuits: 2~15
- ③ L =Length : 40~1000 mm(0100=100 mm)
- ④ Wire Color : 00 = All pin counts of White Color  
01 =All pin counts of Black Color  
02 =All pin counts of Brown Color
- ⑤ Other Options: 0 = Standard

WIRE TO BOARD

**CI22 Series 2.50mm(.098") Wire to Board Connectors DIP Headers**

- ⊙ With locking slot and Pin Kinked
- ⊙ Mate with CI22 housing
- ⊙ Insulator: High temperature plastic UL 94V-0 , Color Nature
- ⊙ With Tin plated 0.64mm square pin

RoHS Compliant

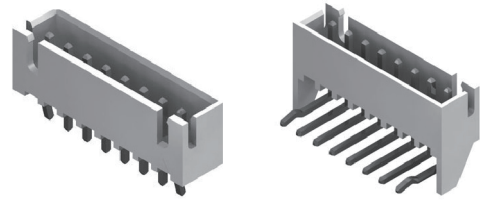

**Straight Type**

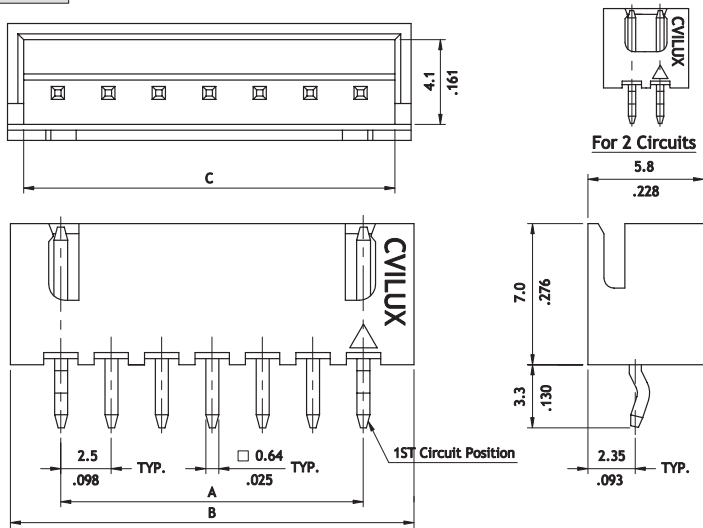

**Right angle Type**

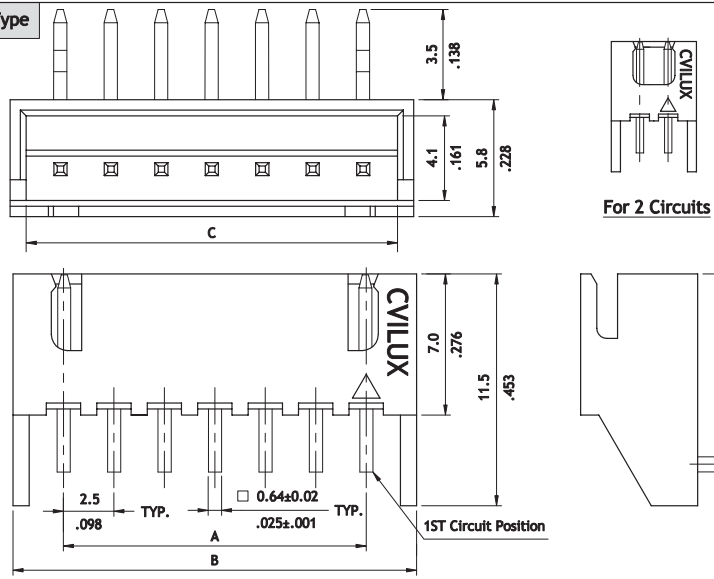

Circuits	Dimension		
	A	B	C
2	2.5(.098)	7.5(.295)	6.0(.236)
3	5.0(.197)	10.0(.394)	8.5(.335)
4	7.5(.295)	12.5(.492)	11.0(.433)
5	10.0(.394)	15.0(.591)	13.5(.531)
6	12.5(.492)	17.5(.689)	16.0(.630)
7	15.0(.591)	20.0(.787)	18.5(.728)
8	17.5(.689)	22.5(.886)	21.0(.827)
9	20.0(.787)	25.0(.984)	23.5(.925)
10	22.5(.886)	27.5(1.083)	26.0(1.024)
11	25.0(.984)	30.0(1.181)	28.5(1.122)
12	27.5(1.083)	32.5(1.280)	31.0(1.220)
13	30.0(1.181)	35.0(1.378)	33.5(1.319)
14	32.5(1.280)	37.5(1.476)	36.0(1.417)
15	35.0(1.378)	40.0(1.575)	38.5(1.516)
16	37.5(1.476)	42.5(1.673)	41.0(1.614)
17	40.0(1.575)	45.0(1.772)	43.5(1.713)
18	42.5(1.673)	47.5(1.870)	46.0(1.811)
19	45.0(1.772)	50.0(1.969)	48.5(1.909)
20	47.5(1.870)	52.5(2.067)	51.0(2.008)

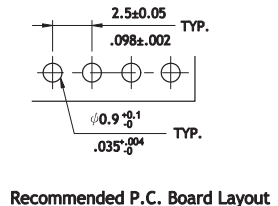

**Ordering Code**

①    ②    ③    ④    ⑤    ⑥    ⑦

**C I 22 20 P 1 V K0 - NH**

① Series No.

② No. of Circuits: 02 ~ 20

③ P = DIP Type

④ Plating Code: 1 = Matte Tin over Nickel

⑤ Type: V = Straight  
H = Right Angle

⑥ Other Options : 00 = Without Pin Kinked  
K0 = With Pin Kinked (Standard)

⑦ NH = For Lead Free soldering process and Halogen-Free  
\*Special options consult manufacturer

**CI25 Series 2.50mm(.098") Wire to Board Connectors Housing & Terminal**

- ⊙ Low profile with locking ribs
- ⊙ Mate with CI25 header
- ⊙ Can be used with CI25 crimp clip terminal
- ⊙ Terminal accommodated AWG #22 ~ #28
- ⊙ Insulator: Nylon 66 UL 94V-0 , Color Ivory
- ⊙ Terminal: Tin plated Phosphor Bronze

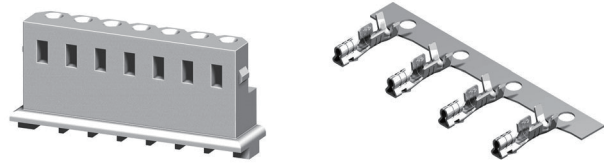

RoHS Compliant

CI

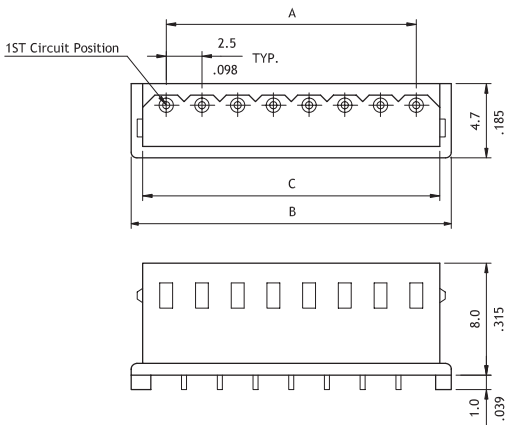

Circuits	Dimension		
	A	B	C
2	2.5(.098)	7.4(.291)	5.8(.228)
3	5.0(.197)	9.9(.390)	8.3(.327)
4	7.5(.295)	12.4(.488)	10.8(.425)
5	10.0(.394)	14.9(.587)	13.3(.524)
6	12.5(.492)	17.4(.685)	15.8(.622)
7	15.0(.591)	19.9(.783)	18.3(.720)
8	17.5(.689)	22.4(.882)	20.8(.819)
9	20.0(.787)	24.9(.980)	23.3(.917)
10	22.5(.886)	27.4(1.079)	25.8(1.016)
11	25.0(.984)	29.9(1.177)	28.3(1.114)
12	27.5(1.083)	32.4(1.276)	30.8(1.213)
13	30.0(1.181)	34.9(1.374)	33.3(1.311)
14	32.5(1.280)	37.4(1.472)	35.8(1.409)
15	35.0(1.378)	39.9(1.571)	38.3(1.508)

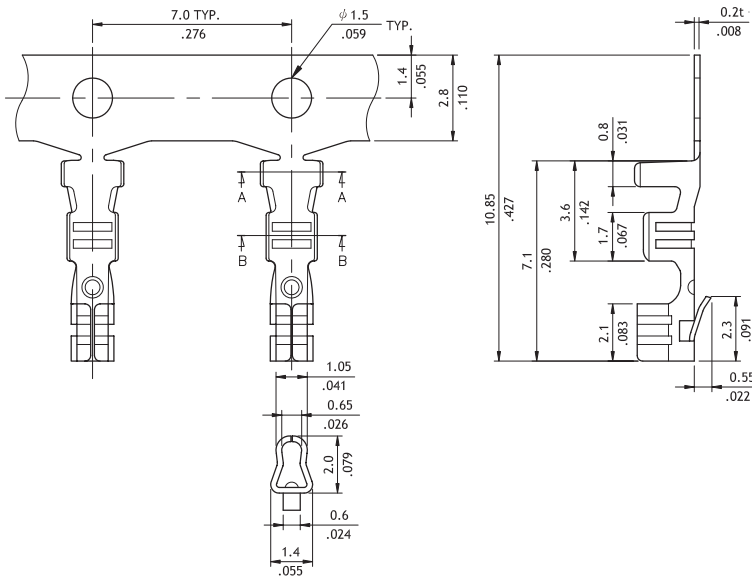
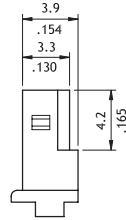

Wire Range	Insulation Diameter	Reel Qty
AWG #22-#28	1.6 (.063) MAX.	10,000 PCS.

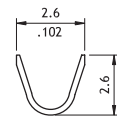

SEC: A-A

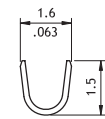

SEC: B-B

**Ordering Code**

① ② ③ ④  
**C I 25 1 2 S 0 0 0 0**

- ① Series No.
- ② No. of Circuits: 02 ~ 15
- ③ S = Housing
- ④ Other Options: 0000 = Standard  
\*Special options consult manufacturer

① ② ③ ④ ⑤  
**C I 25 T 0 2 1 P E 0**

- ① Series No.
- ② Type: T02 = AWG #22 ~ #28
- ③ Plating Code: 1 = Tin over Nickel
- ④ Material: P = Phosphor Bronze
- ⑤ Other Options: E0 = Standard

WIRE TO BOARD

**CI25 Series 2.50mm(.098") Wire to Board Connectors DIP Headers**

- ⊙ With locking slot
- ⊙ Mate with CI25 housing
- ⊙ Insulator: Polyamide UL 94V-0 , Color Ivory
- ⊙ With Tin plated 0.7mm round pin

RoHS Compliant

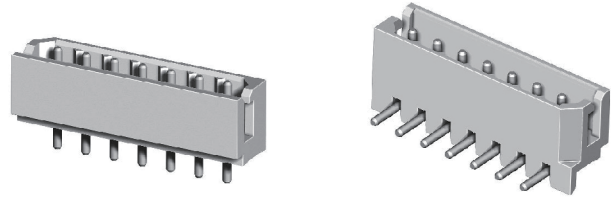

**Straight Type**

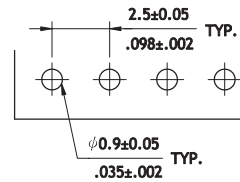
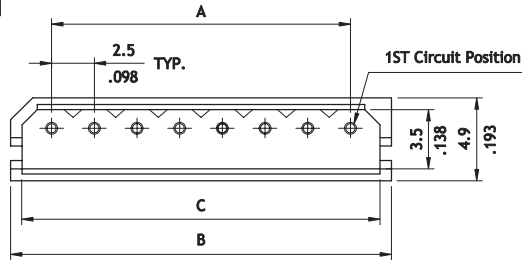

**Recommended P.C. Board Layout**

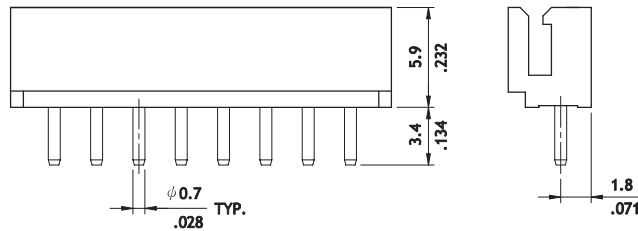

A = 2.5 x No. of Spaces  
 B = A + 5.0  
 C = A + 3.6

**Right angle Type**

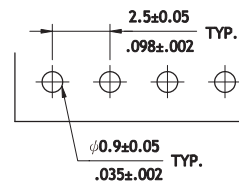
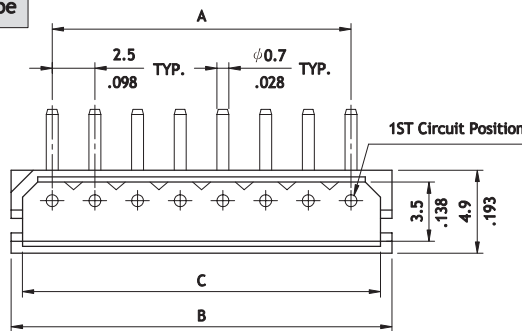

**Recommended P.C. Board Layout**

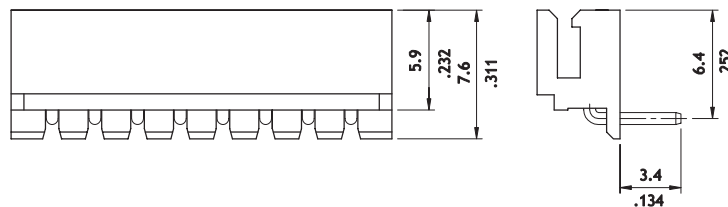

A = 2.5 x No. of Spaces  
 B = A + 5.0  
 C = A + 3.6

**Ordering Code**

① ② ③ ④ ⑤ ⑥ ⑦  
**C I 25 12 P 1 V 00 - NH**

- ① Series No.
- ② No. of Circuits: 02 ~ 15
- ③ P = DIP Type
- ④ Plating Code: 1 = Matte Tin over Nickel
- ⑤ Type : V = Straight  
 H = Right Angle
- ⑥ Other Options:  
 00 = Standard  
 \*Special options consult manufacturer
- ⑦ NH = For Lead Free soldering process and Halogen-Free

**CI30 Series 2.50mm (.098") Wire to Board Connectors DIP Header**

- ⊙ With locking wall
- ⊙ Insulation: Nylon 66 UL 94V-0 , Color Nature

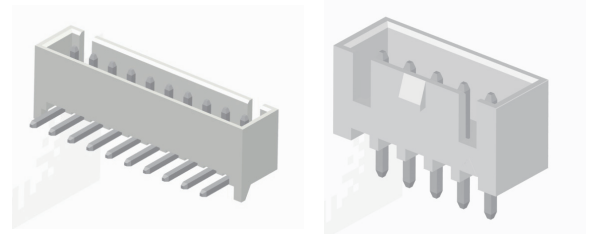

CI

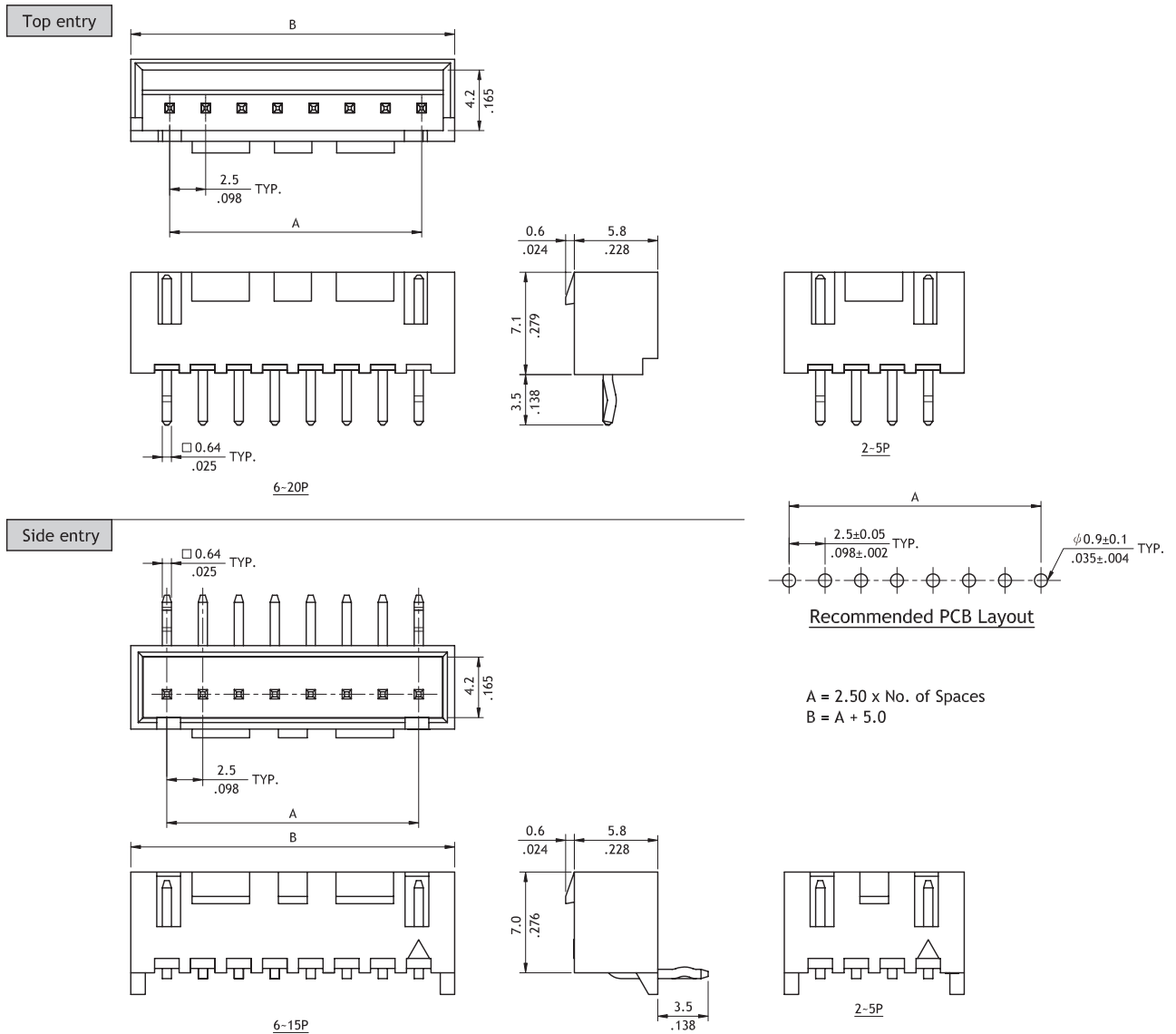

<b>Ordering Code</b>	①	②	③	④	⑤	⑥
	C I 3 0	0 2	P	1	V	K 0 - A
<p>① Series No.</p> <p>② No. of Circuits: 02~16</p> <p>③ P= DIP Header</p> <p>④ Plating Code :1 = Tin over Nickel</p> <p>⑤ Contact Type : V= Straight H= Right Angle</p> <p>⑥ Option : K0 = Standard (With Pin Kinked)</p>						

WIRE TO BOARD

**CI60 Series 2.50mm (.098") Wire to Board Connectors DIP Header&Housing**

- ⊙ With locking wall
- ⊙ Insulation: Nylon 66 UL 94V-0 , Color Nature

**RoHS** Compliant

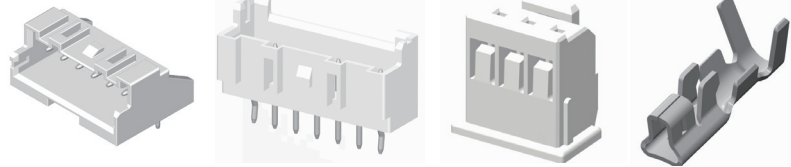

P/N CI60\*\*SL000

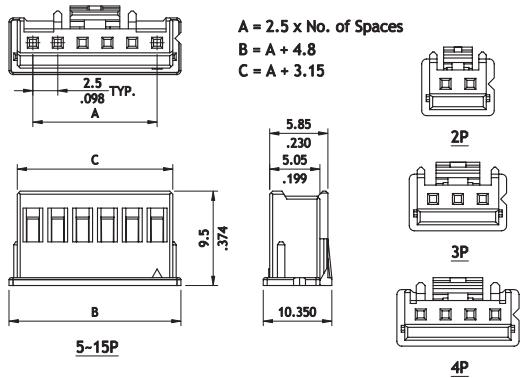

P/N CI60T021PE0

Wire Range	Insulation Diameter	Reel Qty	Material
AWG #22-#28	1.90 (.075) MAX.	8,000 PCS	Phosphor Bronze

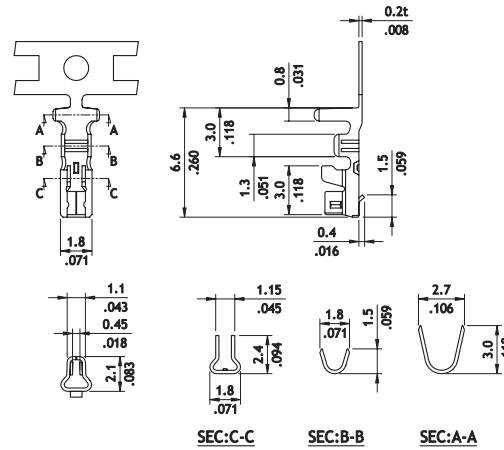

P/N CI60\*\*P1VK0

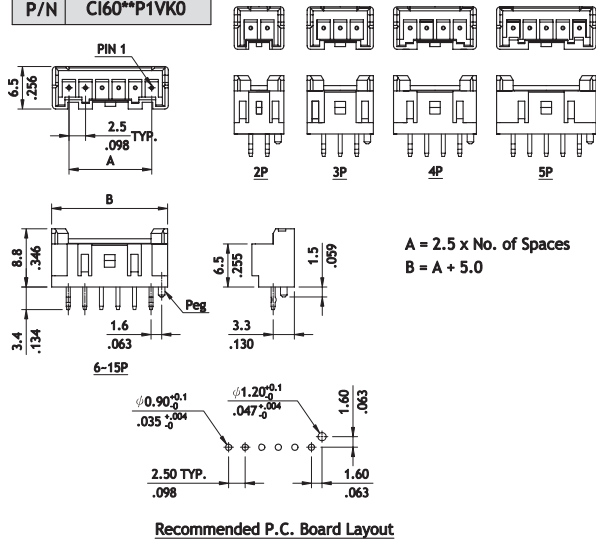

P/N CI60\*\*P1HK0

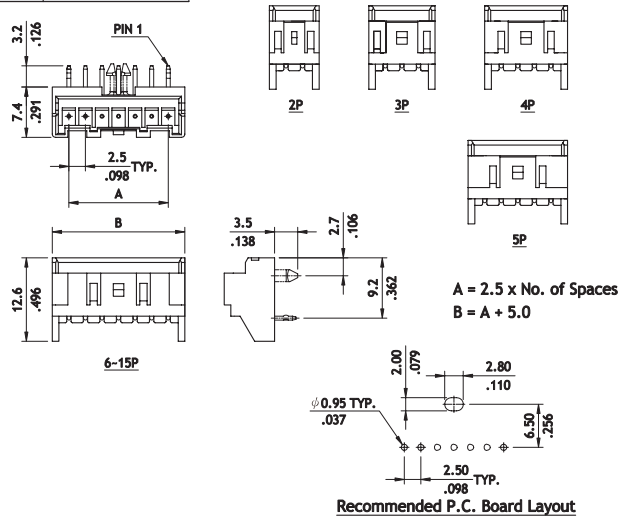

**Ordering Code**

① ② ③ ④ ⑤  
**C I 6 0 1 5 S L 0 0 0**

- ① Series No.
- ② No. of Circuits: 02 ~ 15
- ③ S = Housing
- ④ L=With Locking Latch
- ⑤ Option: 000=Standard ( Color Nature )

① ② ③ ④ ⑤ ⑥  
**C I 6 0 1 5 P 1 V K 0**

- ① Series No.
- ② No. of Circuits: 02 ~ 15
- ③ P = Pin Header
- ④ Plating : 1= Tin over Nickel
- ⑤ Type : V= Straight Type  
H=Right Angle
- ⑥ Other Option: K0= With Pin Kinked

**CIL4 Series 2.5mm(.098") Wire to Board Connectors SMT Headers**

☉ With PAD for SMT Line pick and place machine

RoHS Compliant  

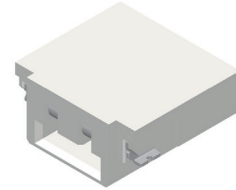

CI

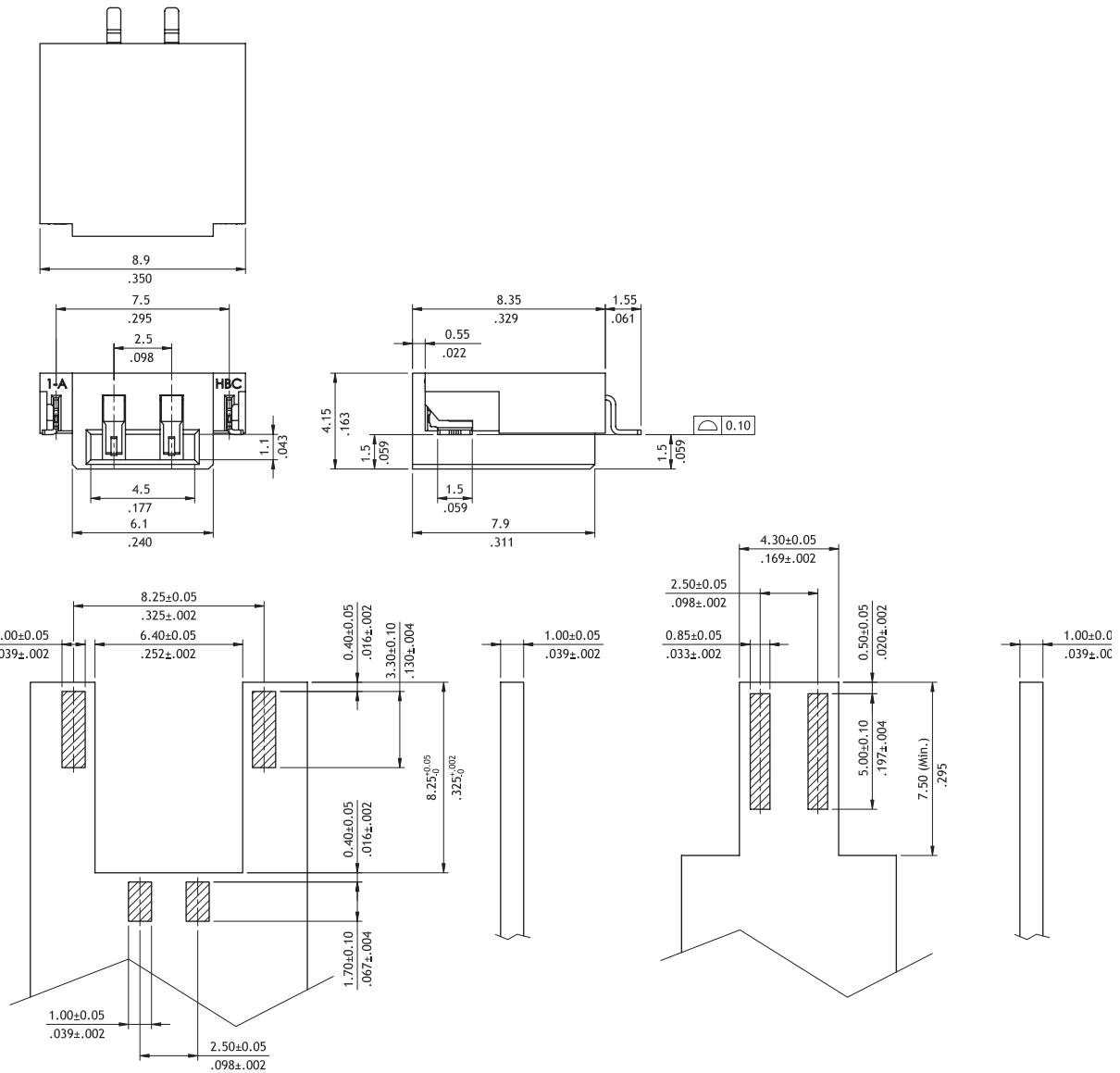

Recommended Connector P.C.B Layout

Recommended Light Bar PCB Layout

**Ordering Code**

① ② ③ ④ ⑤ ⑥ ⑦ ⑧  
**C I L 4 0 2 M 1 H R 0 - N H**

- ① Series No.
- ② No. of Circuits: 02
- ③ M = SMT Type
- ④ Plating Code:  
1 = Matte Tin over Nickel

- ⑤ Type: H = Side Entry
- ⑥ Packing Options:  
R=Tape & Reel
- ⑦ Options: 0 = Standard
- ⑧ NH = For Lead Free IR process and Halogen-Free

WIRE TO BOARD

**CI31 Series 2.54mm(.100") Wire to Board Connectors Housing & Terminal**

- ⊙ With locking ramps and ribs
- ⊙ Mate with CI31, CH31, CI83 header
- ⊙ Can be used with CI31 crimp clip terminal
- ⊙ Insulator: Nylon 66 UL 94V-2, Color Ivory
- ⊙ Terminal: Tin plated Brass or Phosphor Bronze



RoHS Compliant

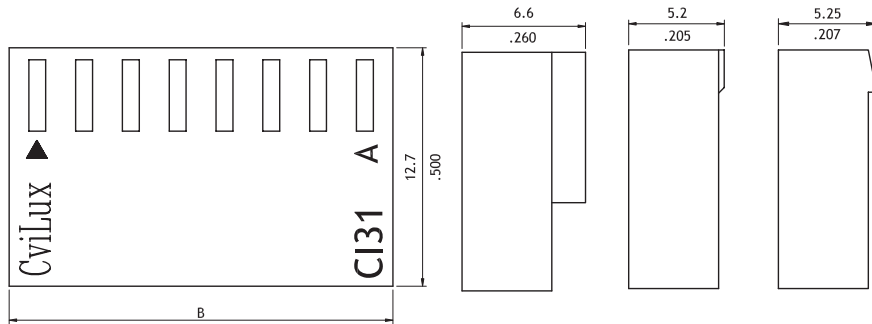
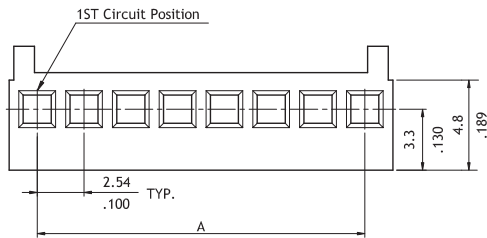

P/N:CI31\*\*S0000    P/N:CI31\*\*SNP00    P/N:CI31\*\*S00R0

Circuits	Dimension	
	A	B
2	2.54(.100)	5.6(.220)
3	5.08(.200)	8.1(.319)
4	7.62(.300)	10.7(.421)
5	10.16(.400)	13.2(.520)
6	12.70(.500)	15.8(.622)
7	15.24(.600)	18.3(.720)
8	17.78(.700)	20.8(.819)
9	20.32(.800)	23.4(.921)
10	22.86(.900)	25.9(1.020)
11	25.40(1.000)	28.5(1.122)
12	27.94(1.100)	31.0(1.220)
13	30.48(1.200)	33.5(1.319)
14	33.02(1.300)	36.1(1.421)
15	35.56(1.400)	38.6(1.520)
16	38.10(1.500)	41.2(1.622)
17	40.64(1.600)	43.7(1.720)
18	43.18(1.700)	46.2(1.819)
19	45.72(1.800)	48.8(1.921)
20	48.26(1.900)	51.3(2.020)

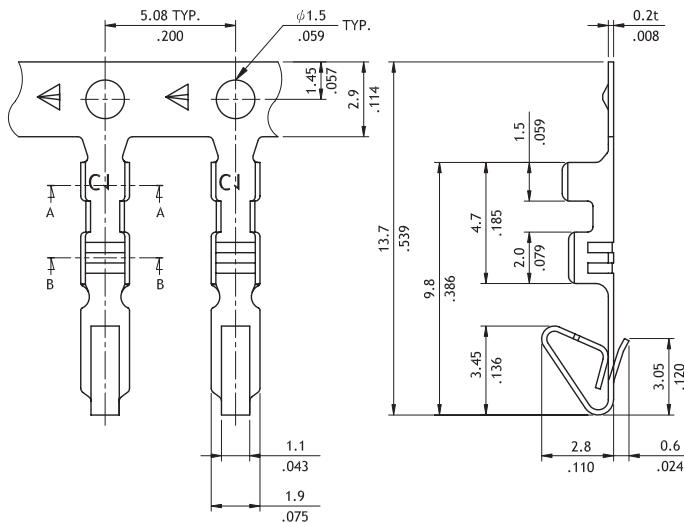

Wire Range	Insulation Diameter	Reel Qty
AWG #22-#28	1.5 (.059) MAX.	10,000 PCS.

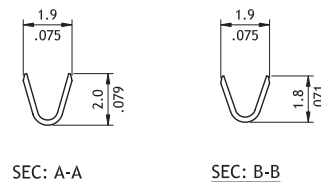

**Ordering Code**

① C I 3 1    ② 2 0    ③ S    ④ 0 0 0 0

- ① Series No.
- ② No. of Circuits: 02 ~ 20
- ③ S = Housing
- ④ Other Options:  
 0000 = With Polarizing Ribs (Long)  
 00R0 = With Polarizing Ribs (Short)  
 NP00 = Without Polarizing Rib  
 \*Special options consult manufacturer

① C I 3 1    ② T 0 2    ③ 1    ④ B    ⑤ E 0

- ① Series No.
- ② Type: T02 = AWG #22 ~ #28
- ③ Plating Code: 1 = Tin over Nickel
- ④ Material: B = Brass  
 P = Phosphor Bronze
- ⑤ Other Options: E0 = Standard

CI31 Series 2.54mm(.100") Wire to Board Connectors DIP Headers

- ⊙ With locking ramps and ribs
- ⊙ Mate with CI31 Housing
- ⊙ Insulator: High temperature plastic UL 94V-0, Color Nature
- ⊙ Terminal: Matte Tin plated Brass

RoHS Compliant 

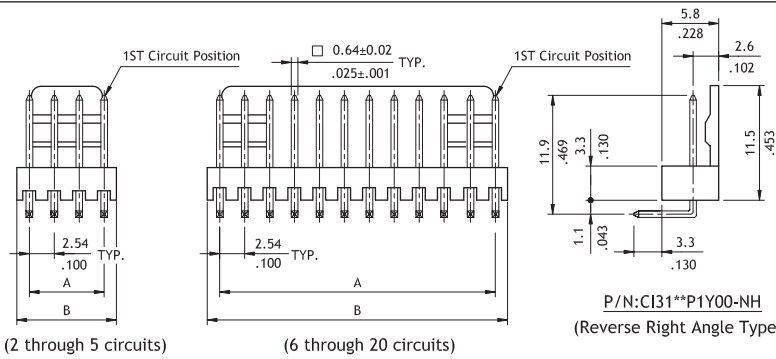
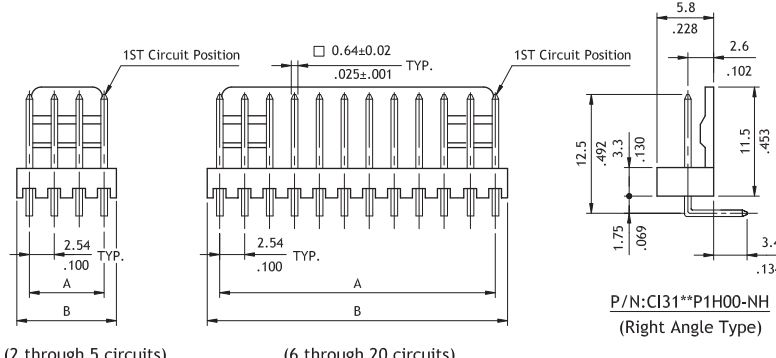
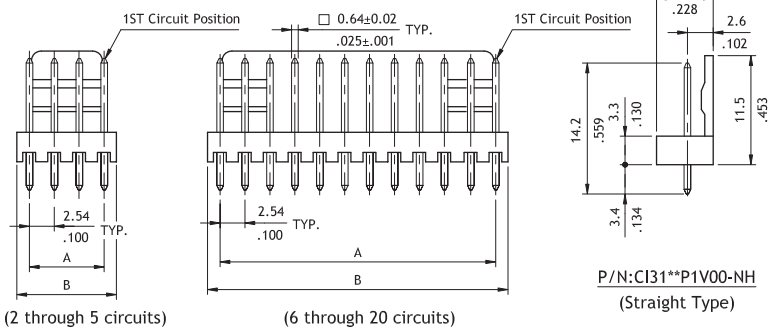
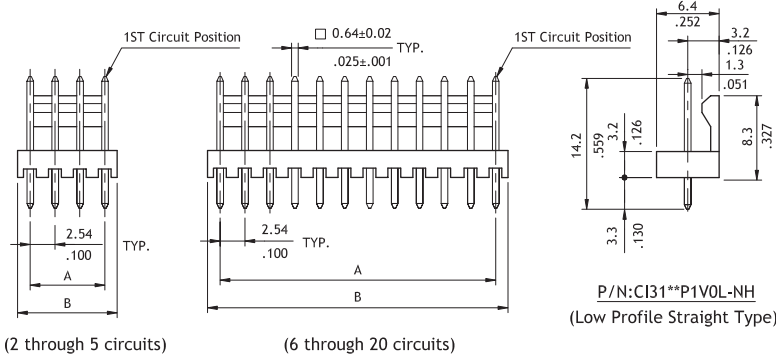
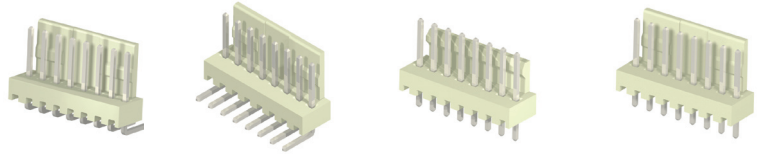

Circuits	Dimension	
	A	B
2	2.54(.100)	5.1(.201)
3	5.08(.200)	7.6(.299)
4	7.62(.300)	10.2(.402)
5	10.16(.400)	12.7(.500)
6	12.70(.500)	15.2(.598)
7	15.24(.600)	17.8(.701)
8	17.78(.700)	20.3(.799)
9	20.32(.800)	22.9(.902)
10	22.86(.900)	25.4(1.000)
11	25.40(1.000)	27.9(1.098)
12	27.94(1.100)	30.5(1.201)
13	30.48(1.200)	33.0(1.299)
14	33.02(1.300)	35.6(1.402)
15	35.56(1.400)	38.1(1.500)
16	38.10(1.500)	40.6(1.598)
17	40.64(1.600)	43.2(1.701)
18	43.18(1.700)	45.7(1.799)
19	45.72(1.800)	48.3(1.902)
20	48.26(1.900)	50.8(2.000)

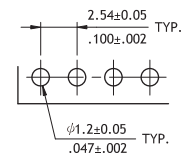

Recommended PCB Layout

**CI39 Series 2.54mm(.100") Wire to Board Connectors SMT Headers**

- ⊙ Locking wall provide secure mating
- ⊙ With PAD for SMT Line pick and place machine
- ⊙ Insulator: High temperature plastic UL 94V-0, Color Nature
- ⊙ With Tin plated SMT type contact

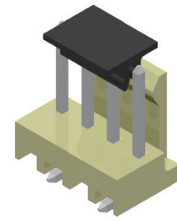

RoHS Compliant

CI

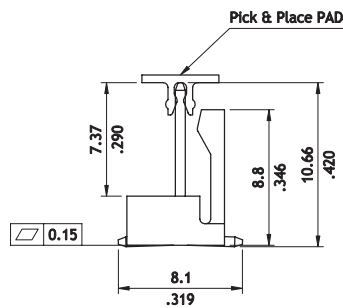
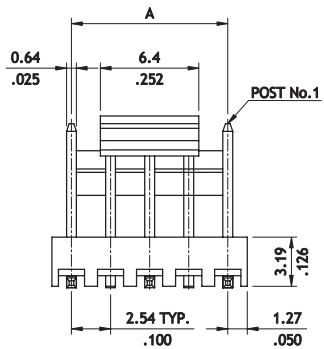
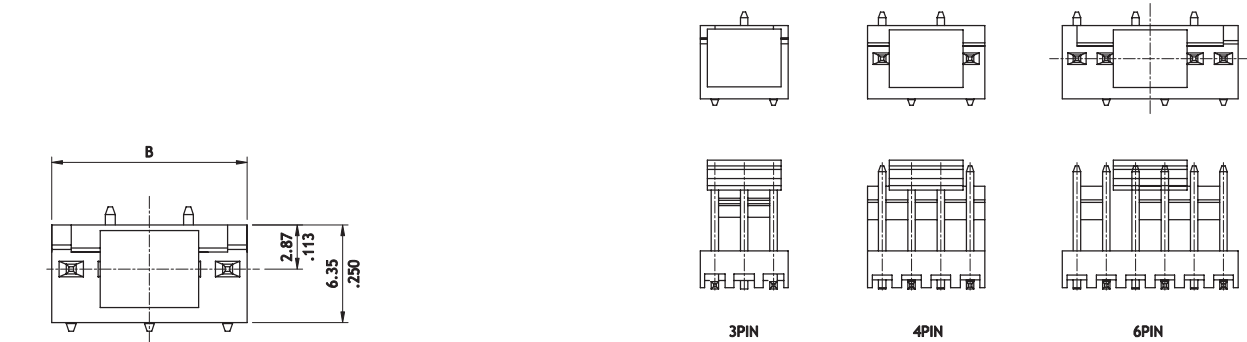

$A = 2.54 \times \text{No. of Spaces}$   
 $B = A + 2.54$

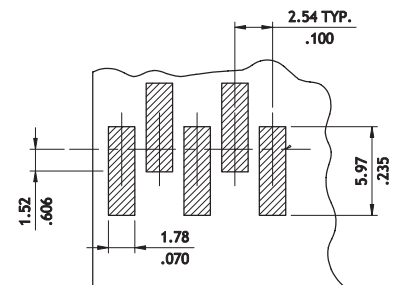

**Recommended P.C. Board Layout**

Ordering Code	①	②	③	④	⑤	⑥	⑦	⑧						
	C	I	3	9	0	4	M	1	V	R	0	-	N	H

① Series No.  
 ② No. of Circuits: 03 ~ 06  
 ③ M = SMT Type  
 ④ Plating Code:  
 1= Matte Tin over Nickel

⑤ Type: V = Straight  
 ⑥ Packing Options: R = Tape & Reel  
 ⑦ Other Options: 0 = Standard  
 ⑧ NH = For Lead Free IR process and Halogen-Free

WIRE TO BOARD

**CI83 Series 2.54mm(.100") Friction Lock Breakaway Headers**

- ⊙ Options with straight and right angle tails
- ⊙ Available with flat back wall for polarization
- ⊙ Mate with most of 2.54mm pitch connector in the market
- ⊙ Insulator: Glass filled polyester UL 94V-0, Color White
- ⊙ With Tin plated 0.64mm square pin

RoHS Compliant 

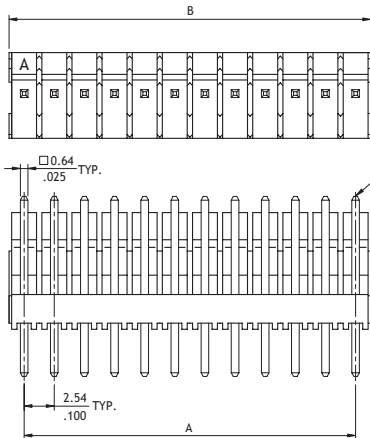
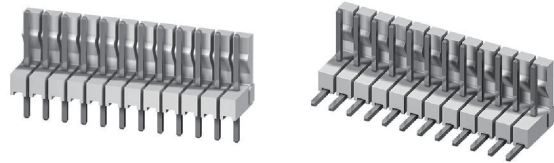

$A = 2.54 \times \text{No. of Spaces}$   
 $B = A + 2.54$

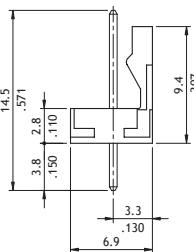

P/N: CI83\*\*P\*V00

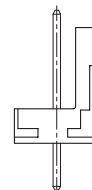

P/N: CI83\*\*P\*V0L

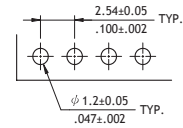

Recommended PCB Layout

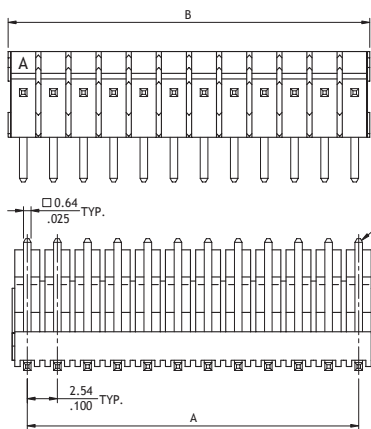

$A = 2.54 \times \text{No. of Spaces}$   
 $B = A + 2.54$

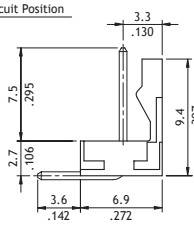

P/N: CI83\*\*P\*H00

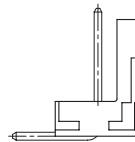

P/N: CI83\*\*P\*H0L

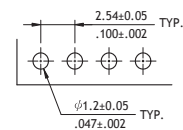

Recommended PCB Layout

**Ordering Code**

① ② ③ ④ ⑤ ⑥  
**CI83 36 P 1 V 00**

- ① Series No.
- ② No. of Circuits: 02 ~ 36
- ③ P = DIP Header
- ④ Plating Code :1 = Tin over Nickel

- ⑤ Type: V = Straight  
 H = Right Angle
- ⑥ Other Options:  
 00 = With Locking Ramp (Standard)  
 0L = Without Locking Ramp  
 \*Special options consult manufacturer

**CID2 Series 2.54mm(.100") IDC Type Connectors**

- ⊙ Terminal: Tin-plated Phosphor Bronze
- ⊙ Housing: Nylon 66 UL 94V-2
- ⊙ With or without locking ramp and polarizing tabs
- ⊙ Feed-Thru and Closed End type
- ⊙ Wire range AWG #22 ~ #28 (Flat ribbon wire)
- ⊙ Mate with CI31 Headers

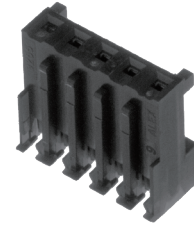

**RoHS** Compliant

**Closed End type Without Polarizing Tabs**

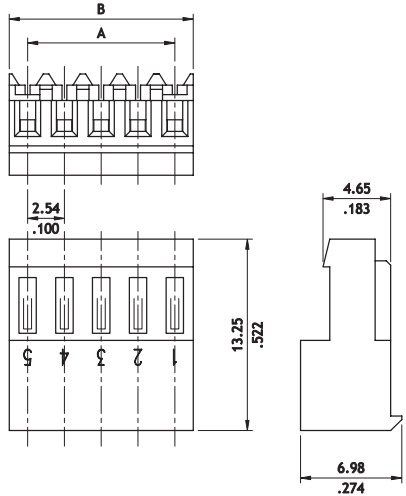

**Closed End type With Polarizing Tabs**

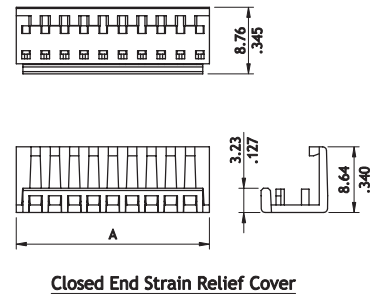
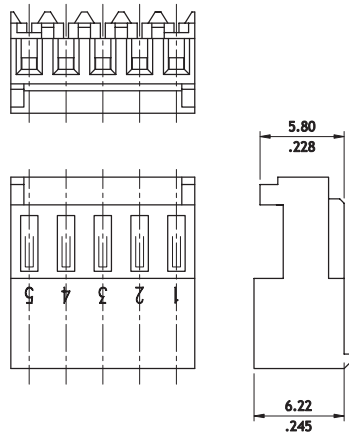

**Feed-Thru type With Polarizing Tabs**

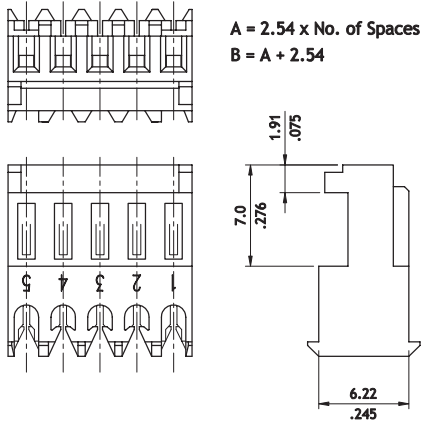

**Feed-Thru type Without Polarizing Tabs**

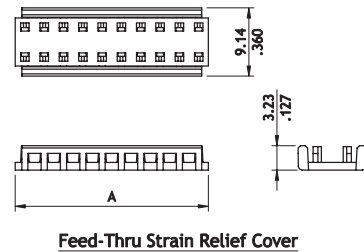
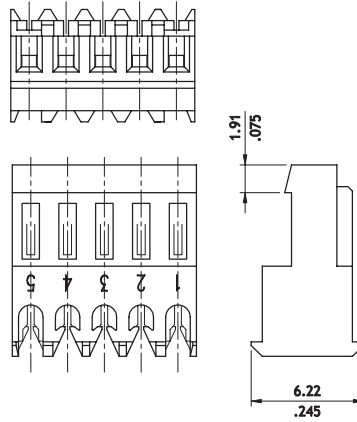

**Ordering Code**

① ② ③ ④ ⑤ ⑥ ⑦  
**C I D 2 2 4 S 1 A 0 0**

- ① Series No.
- ② No. of Circuits: 02 ~ 24
- ③ S = Housing
- ④ Plating Code: 1 = Tin over Nickel
- ⑤ Type : A = Closed End Type  
B = Feed-Thru Type
- ⑥ Color Options:  
0 = Color white, for AWG #24  
3 = Color red, for AWG #22  
6 = Color green, for AWG #28  
7 = Color blue, for AWG #26
- ⑦ Other Options:  
0 = W/O Polarizing Tabs  
P = With Polarizing Tabs

**CID7 2.54mm (.100") Wire to Board Housing / Terminal & DIP Headers**

- ⊙ Box type with locking slot
- ⊙ Insulator : Glass filled polyester UL 94V-0 , color black
- ⊙ With Tin plated 0.64mm square pin

RoHS Compliant

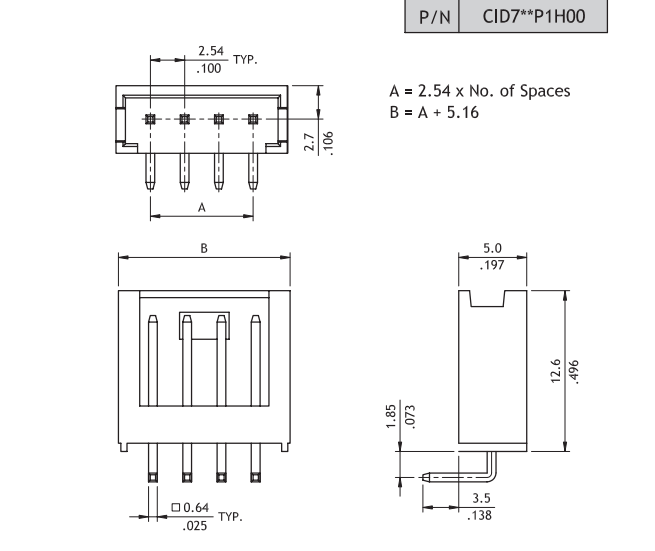
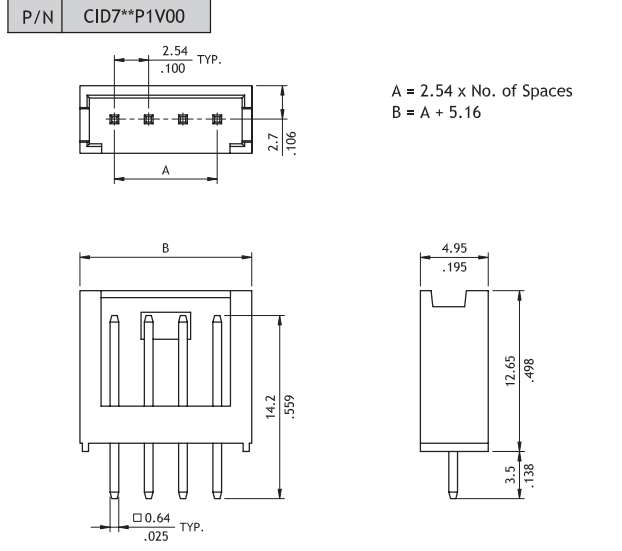
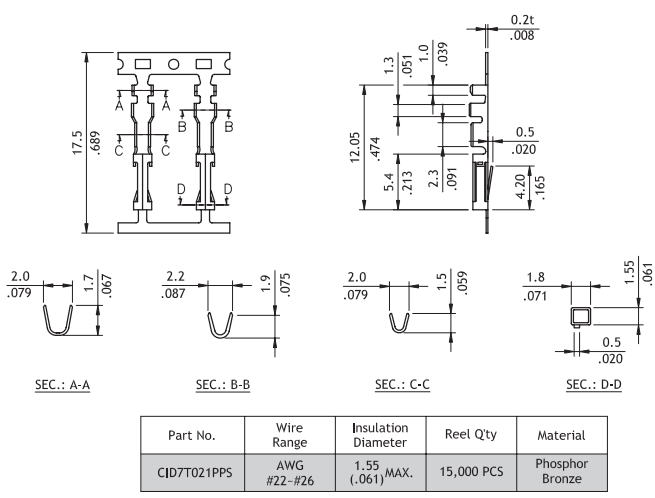
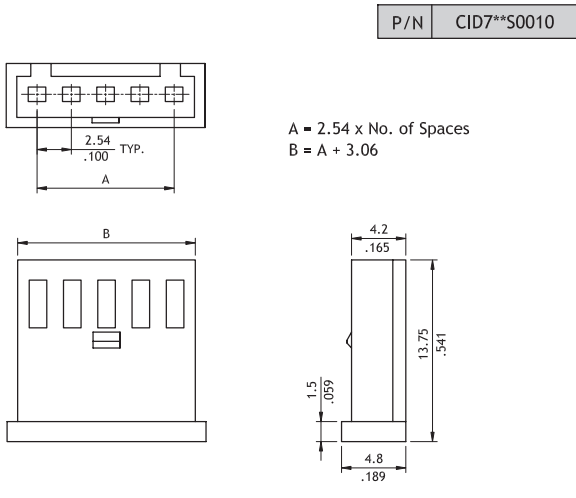
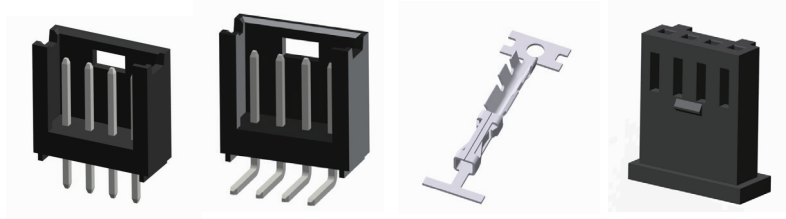

**Ordering Code**

① CID7 ② 10 ③ S ④ 0010

- ① Series No.
- ② No. of Circuits: 02 ~ 10
- ③ S = Housing
- ④ Other Option:  
0010= Color Black (Standard)

① CID7 ② 10 ③ P ④ 1 ⑤ V ⑥ 00

- ① Series No.
- ② No. of Circuits: 02 ~ 10
- ③ P = DIP Header
- ④ Plating Code: 1= Tin over Nickel  
H=Right Angle
- ⑤ Type : V=Straight  
H=Right Angle
- ⑥ Other Option: 00 =Standard

**CI51 Series 3.96mm(.156") Wire to Board Connectors Housing & Terminal**

- ⊙ With locking ramp
- ⊙ Mate with CI51, CI77 Header
- ⊙ Can be used with CI51 crimp clip terminal
- ⊙ Insulator: Nylon 66 UL 94V-2, Color Nature
- ⊙ Terminal: Tin plated Phosphor Bronze

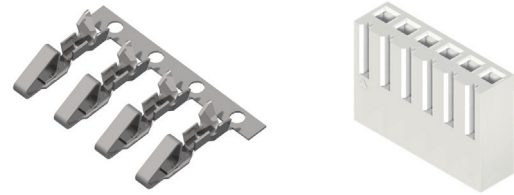

RoHS Compliant

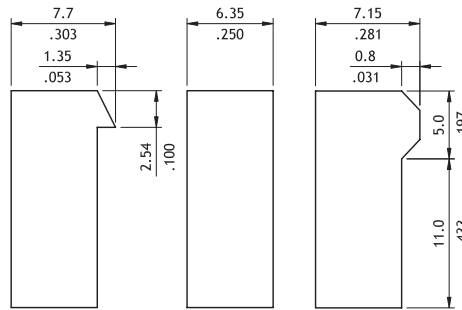
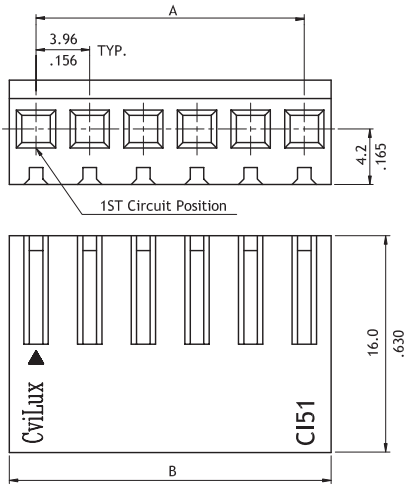

Circuits	Dimension	
	A	B
2	3.96(.156)	8.0(.315)
3	7.92(.312)	12.0(.472)
4	11.88(.468)	15.9(.626)
5	15.84(.624)	19.9(.783)
6	19.80(.780)	23.9(.941)
7	23.76(.935)	28.0(1.102)
8	27.72(1.091)	32.0(1.260)
9	31.68(1.247)	35.9(1.413)
10	35.64(1.403)	39.9(1.571)
11	39.60(1.559)	43.9(1.728)
12	43.56(1.715)	47.8(1.882)
13	47.52(1.871)	51.8(2.039)
14	51.48(2.027)	55.7(2.193)
15	55.44(2.183)	59.7(2.350)
16	59.40(2.339)	63.7(2.508)
17	63.36(2.494)	67.6(2.661)
18	67.32(2.650)	71.6(2.819)
19	71.28(2.806)	75.5(2.972)
20	75.24(2.962)	79.5(3.130)

P/N:CI51\*\*S0000    P/N:CI51\*\*S000R    P/N:CI51\*\*S00DR

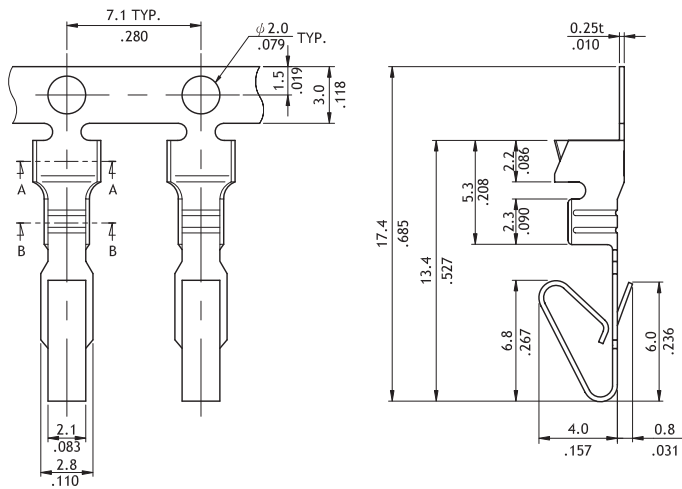

Wire Range	Insulation	Reel Qty
AWG #18-#24	2.10 (.083) MAX.	5,000 PCS

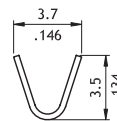

SEC: A-A

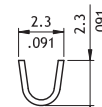

SEC: B-B

**Ordering Code**

① CI51    ② 20    ③ S    ④ 0000

- ① Series No.
- ② No. of Circuits: 02 ~ 20
- ③ S = Housing
- ④ Other Options:  
 0000 = With Locking Ramp (Standard)  
 000R = Without Locking Ramp  
 00DR = Low force Locking Ramp  
 \*Special options consult manufacturer

① CI51    ② T03    ③ 1    ④ P    ⑤ E0

- ① Series No.
- ② Type: T03 = AWG #18 ~ #24
- ③ Plating Code: 1 = Tin over Nickel
- ④ Material: P = Phosphor Bronze
- ⑤ Other Options: E0 = Standard

**CI51 Series 3.96mm(.156") Wire to Board Connectors DIP Headers**

- ⊙ With locking wall
- ⊙ Mate with CI51 Housing
- ⊙ Insulator: Nylon 66 UL 94V-2, Color Nature
- ⊙ With Tin plated 1.14mm square pin

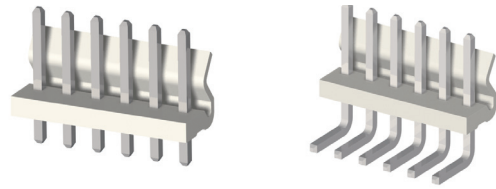

RoHS Compliant  

CI

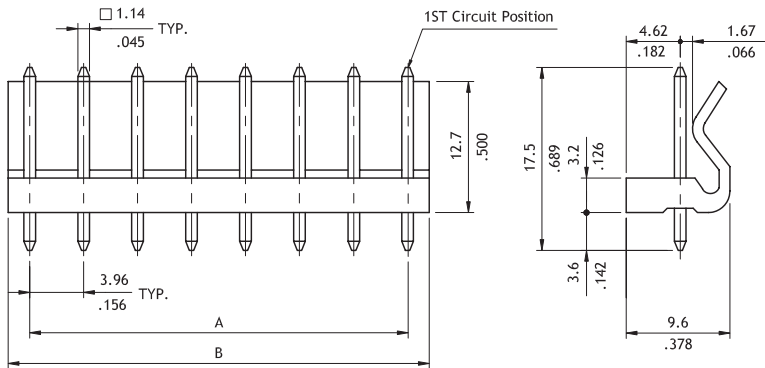

Circuits	Dimension	
	A	B
2	3.96(.156)	7.92(.312)
3	7.92(.312)	11.88(.468)
4	11.88(.468)	15.84(.624)
5	15.84(.624)	19.8(.780)
6	19.80(.780)	23.76(.935)
7	23.76(.935)	27.72(1.091)
8	27.72(1.091)	31.68(1.247)
9	31.68(1.247)	35.64(1.403)
10	35.64(1.403)	39.6(1.559)
11	39.60(1.559)	43.56(1.715)
12	43.56(1.715)	47.52(1.871)
13	47.52(1.871)	51.48(2.027)
14	51.48(2.027)	55.44(2.183)
15	55.44(2.183)	59.4(2.339)
16	59.40(2.339)	63.36(2.494)
17	63.36(2.494)	67.32(2.650)
18	67.32(2.650)	71.28(2.806)
19	71.28(2.806)	75.24(2.962)
20	75.24(2.962)	79.2(3.118)

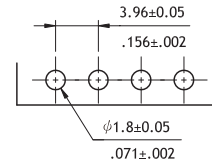
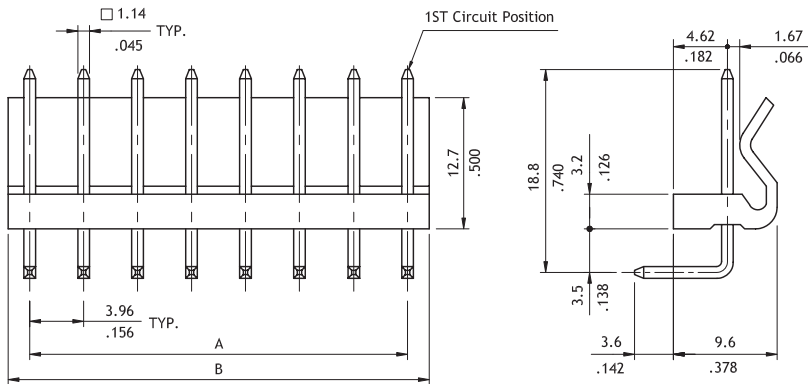

Recommended P.C. Board Layout

**Ordering Code**

① ② ③ ④ ⑤ ⑥  
**CI51 20 P 1 V 00**

- ① Series No.
  - ② No. of Circuits: 02 ~ 20
  - ③ P = DIP Header
  - ④ Plating Code :1 = Tin over Nickel
  - ⑤ Type: V = Straight , H = Right Angle
  - ⑥ Other Options : 00 = Standard
- \*Special options consult manufacturer

WIRE TO BOARD

**CI52 Series 3.96mm(.156") Wire to Board Connectors Housing & Terminal**

- ⊙ With locking latch
- ⊙ Mate with CI52 header
- ⊙ Can be used with CI52 crimp clip terminal
- ⊙ Insulator: Nylon 66 UL 94V-0 , Color Nature
- ⊙ Terminal: Tin plated Brass or Phosphor Bornze

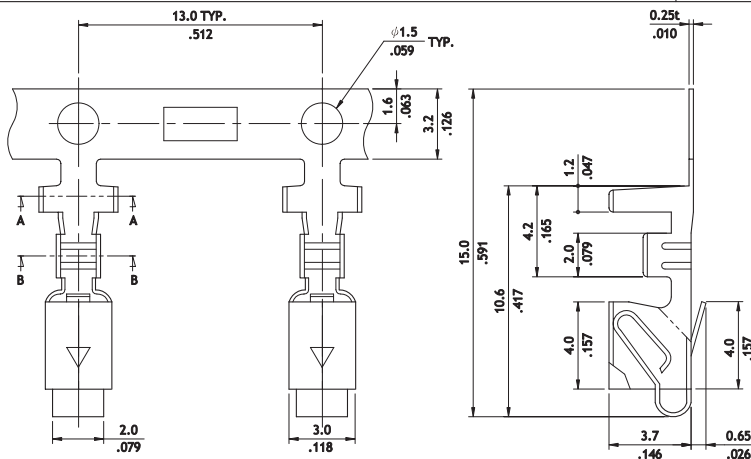
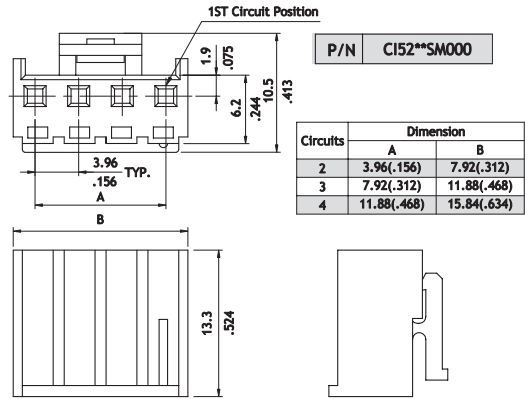
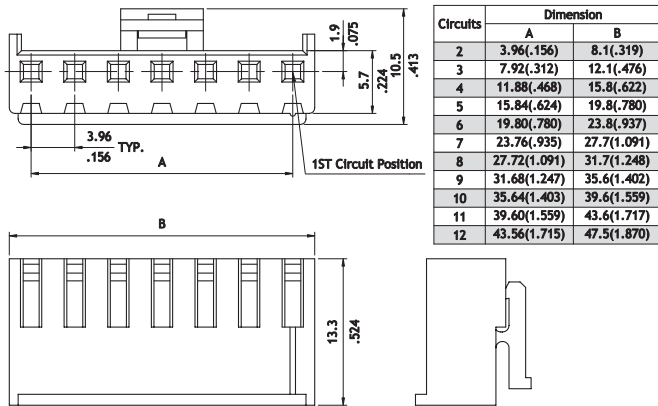
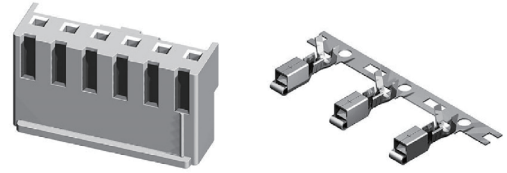

Part No.	Wire Range	Insulation Diameter	Reel Q'ty
CI52T021*E0	AWG #22-#28	1.90 (.075) MAX.	3,500 PCS
CI52T031*E0	AWG #18-#22	2.70 (.106) MAX.	3,500 PCS

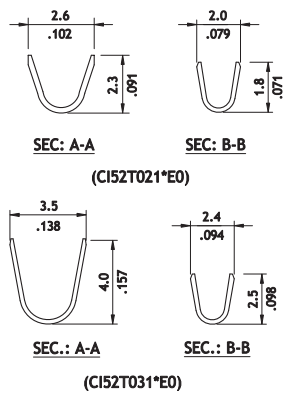

**Ordering Code**

① C ② I ③ 5 ④ 2 ⑤ 1 ⑥ 2 ⑦ S ⑧ 0 ⑨ 0 ⑩ 0 ⑪ 0

- ① Series No.
- ② No. of Circuits: 02 ~ 12
- ③ S = Housing
- ④ Other Options:  
0000 = Standard  
M000 = Special Type  
\*Special options consult manufacturer

① C ② I ③ 5 ④ 2 ⑤ T ⑥ 0 ⑦ 3 ⑧ 1 ⑨ B ⑩ E ⑪ 0

- ① Series No.
- ② Type: T02 = AWG #22 ~ #28  
T03 = AWG #18 ~ #22
- ③ Plating Code: 1 = Tin over Nickel
- ④ Material: B = Brass ; P = Phosphor Bronze
- ⑤ Other Options: E0 = Standard

**CI52 Series 3.96mm(.156") Wire to Board Connectors DIP Headers**

- ⊙ With locking wall
- ⊙ Mate with CI52 Housing
- ⊙ Insulator: Polyamide UL 94V-0, Color Nature
- ⊙ With Tin plated 1.14mm square pin

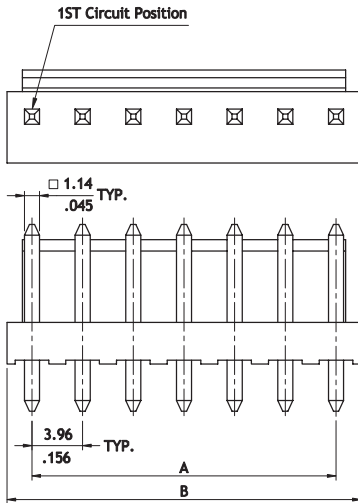
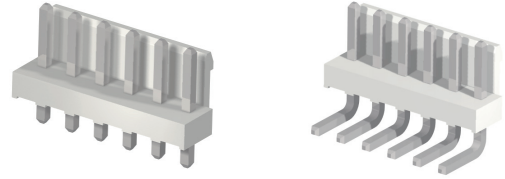

Circuits	Dimension	
	A	B
2	3.96(.156)	7.8(.307)
3	7.92(.312)	11.8(.465)
4	11.88(.468)	15.8(.622)
5	15.84(.624)	19.7(.776)
6	19.80(.780)	23.7(.933)
7	23.76(.936)	27.6(1.087)
8	27.72(1.091)	31.6(1.244)
9	31.68(1.247)	35.5(1.398)
10	35.64(1.403)	39.5(1.555)
11	39.60(1.559)	43.5(1.713)
12	43.56(1.715)	47.4(1.866)

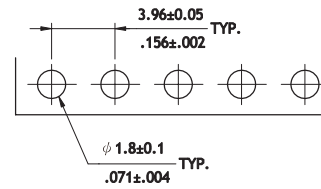
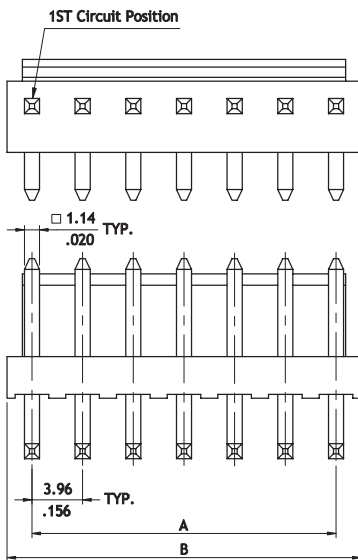

**Recommended P.C. Board Layout**

**Ordering Code**

① ② ③ ④ ⑤ ⑥ ⑦  
**CI52 13 P 1 V 00 - NH**

- ① Series No.
- ② No. of Circuits: 02 ~ 13
- ③ P = DIP Header
- ④ Plating Code: 1 = Tin over Nickel
- ⑤ Type: V = Straight  
H = Right Angle

- ⑥ Other Options:  
00 = Standard  
\*Special options consult manufacturer
- ⑦ NH = For Lead Free Soldering process and Halogen-Free

**CI52 Series 7.92mm(.312") Wire to Board Connectors DIP Headers**

- ⊙ With locking wall
- ⊙ Mate with CI52 Housing
- ⊙ Insulator: Polyamide UL 94V-0, Color Nature
- ⊙ With Tin plated 1.14mm Square pin

RoHS Compliant

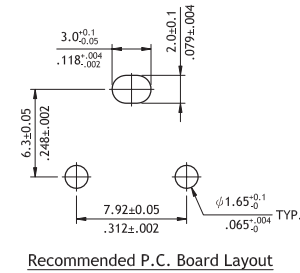
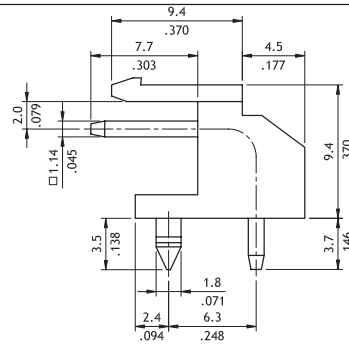
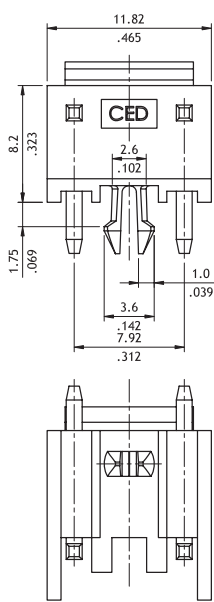
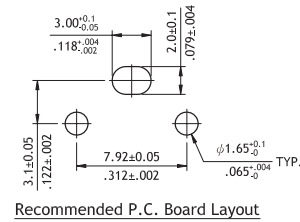
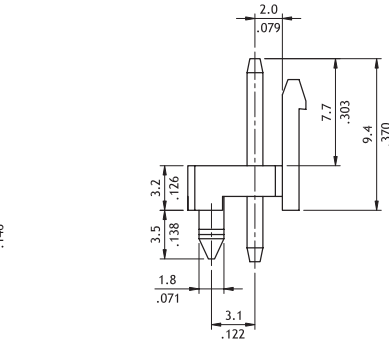
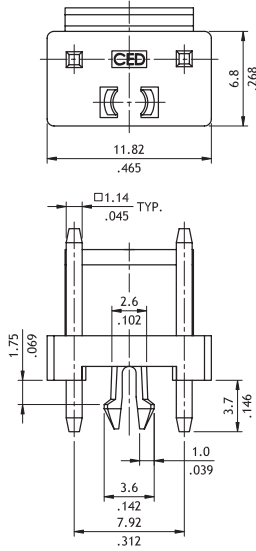
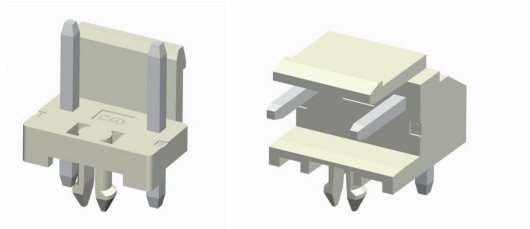

**Ordering Code**

- ①    ②    ③    ④    ⑤    ⑥

**C I 5 2   0 2   P   1   V   D 0**

- ① Series No.
- ② No. of Circuits: 02
- ③ P = Pin Header
- ④ Plating Code: 1 = Matte Tin over Nickel

- ⑤ Type: V = Straight  
H = Right Angle
- ⑥ Other Options:  
D0 = With Plastic Board Lock

**CI82 Series 3.96mm(.156") Friction Lock Breakway Headers**

- ⊙ Options with straight and right angle tails
- ⊙ Available with flat back wall for polarization
- ⊙ Mate with most of 3.96mm pitch connector in the market
- ⊙ Insulator: Glass filled polyester UL 94V-0, Color White
- ⊙ With Tin plated 1.14mm square pin

RoHS Compliant 

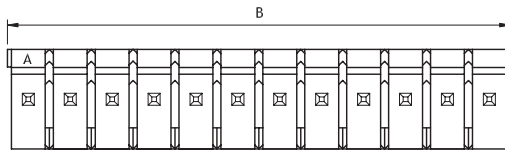
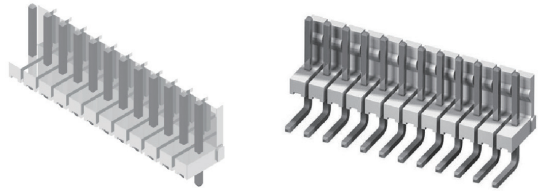

$A = 3.96 \times \text{No. of Spaces}$   
 $B = A + 3.96$

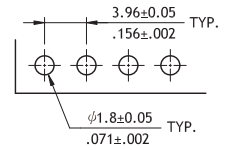

Recommended P.C. Board Layout

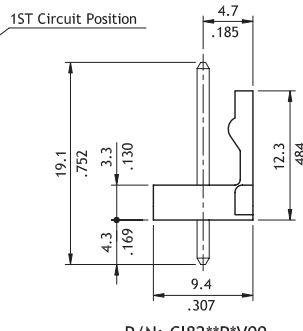
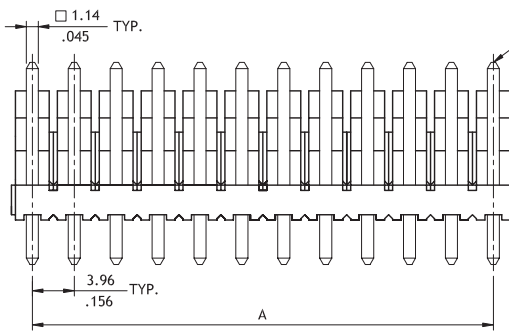

P/N: CI82\*\*P\*V00

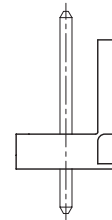

P/N: CI82\*\*P\*V00L

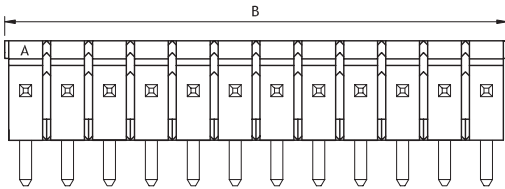

$A = 3.96 \times \text{No. of Spaces}$   
 $B = A + 3.96$

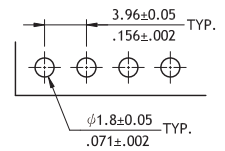

Recommended P.C. Board Layout

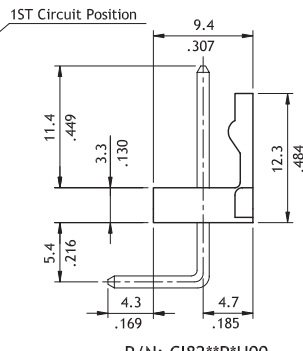
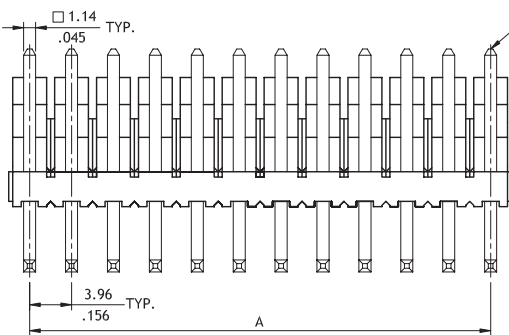

P/N: CI82\*\*P\*H00

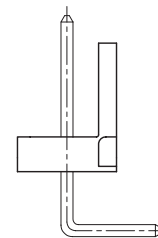

P/N: CI82\*\*P\*H0L

**Ordering Code**

- ①    ②    ③    ④    ⑤    ⑥

**C I 8 2   2 4   P   1   V   0 0**

- ① Series No.
- ② No. of Circuits: 02 ~ 24
- ③ P = DIP Header
- ④ Plating Code :1 = Tin over Nickel

- ⑤ Type: V = Straight  
 H = Right Angle
- ⑥ Other Options:  
 00 = With Locking Ramp (Standard)  
 0L = Without Locking Ramp  
 \*Special options consult manufacturer

**CI77/CI78 Series 3.96mm(.156") / 5.00mm(.196") Breakaway Pin Headers**

- ⊙ Mate with CI51 and CID3 Connector
- ⊙ Available straight and right angle type
- ⊙ Options plating available
- ⊙ Insulator: Glass filled polyester UL 94V-0, Color White
- ⊙ With Tin plated 1.14mm square pin

RoHS Compliant

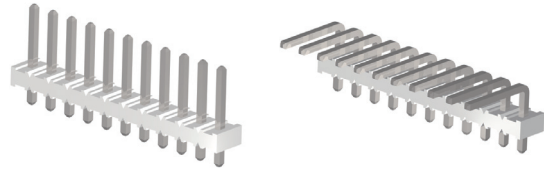

P/N CI77\*\*P1\*00

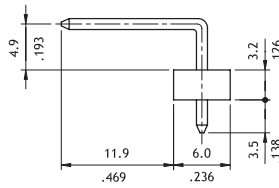
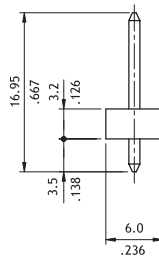
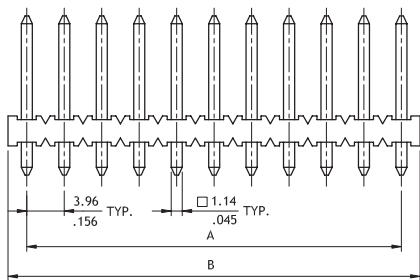

A = 3.96 x No. of Spaces  
B = A + 3.96

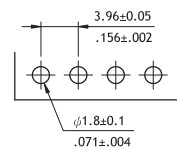

Recommended P.C. Board Layout

P/N CI78\*\*P1\*00

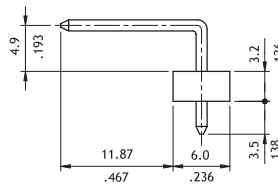
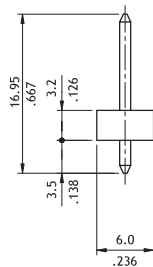
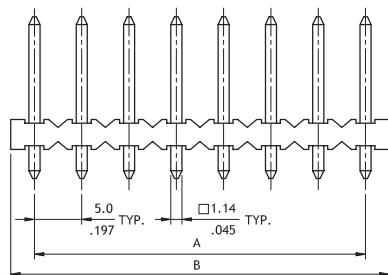

A = 5.0 x No. of Spaces  
B = A + 5.0

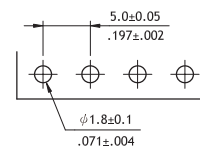

Recommended P.C. Board Layout

<b>Ordering Code</b>	①	②	③	④	⑤	⑥
	<b>C I 7 7</b>	<b>2 0</b>	<b>P</b>	<b>1</b>	<b>V</b>	<b>0 0</b>
<p>① Series No. CI77 = 3.96mm center spacing CI78 = 5.00mm center spacing</p> <p>② No. of Circuits: 02 ~ 20</p> <p>③ P = DIP Header</p> <p>④ Plating Code: 1 = Tin over Nickel</p> <p>⑤ Type: V = Straight , H = Right Angle</p> <p>⑥ Other Options: 00 = Standard *Special options consult manufacturer</p>						

**CID1 Series 4.00mm(.157") Wire to Board SMT Headers**

- ⊙ Surface mount terminal strips with connection
- ⊙ Direct push-in of solid conductors
- ⊙ A total height of only 3.2mm helps minimize shadowing in LED application
- ⊙ Packaged in tape-and-reel for automated SMT processes
- ⊙ Wiring ports with balcony design – creates "lead-in" for ease of wiring, even at a slight angle

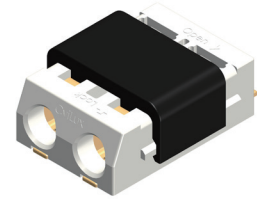

RoHS Compliant  

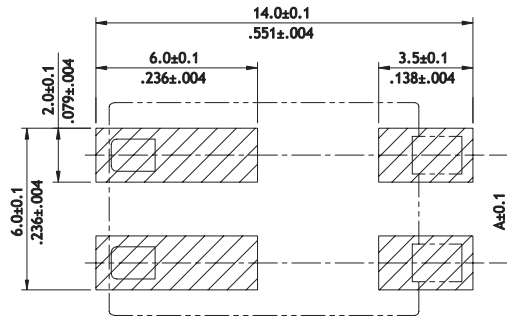
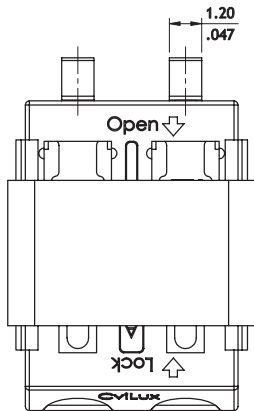

**Recommended P.C. Board Layout**

Circuits	Dimension		
	A	B	C
1	-	3.9(.154)	5.2(.205)
2	4.0(.157)	7.9(.311)	9.2(.362)

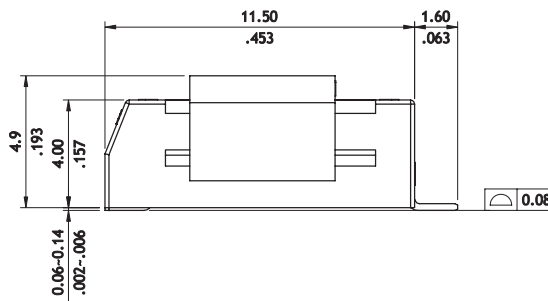
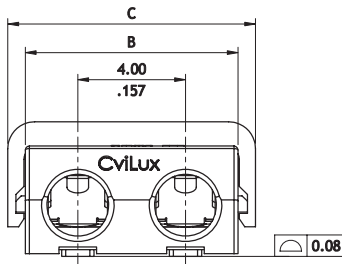

**Ordering Code**

① ② ③ ④ ⑤ ⑥ ⑦  
**CID1 03 M 1 H RA - NH**

- ① Series No.
- ② No. of Circuits: 01~03
- ③ M = SMT Type
- ④ Plating Code: 1 = Matte Tin over Nickel
- ⑤ Type : H = Side Entry
- ⑥ Packing Option : RA = Reel Packing
- ⑦ NH = For Lead Free IR Process and Halogen-Free

**CI55 Series 5.08mm(.200") Wire to Board Header & Housing Connectors**

- ⊙ Housing with locking ramp
- ⊙ Header with locking wall
- ⊙ Can be used with CI51 crimp clip terminal
- ⊙ Insulator: Nylon 66 UL 94V-2, Color Nature
- ⊙ With Tin plated 1.14mm square pin
- ⊙ Terminal: Tin plated Brass

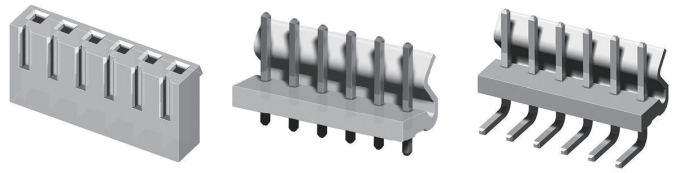

RoHS Compliant

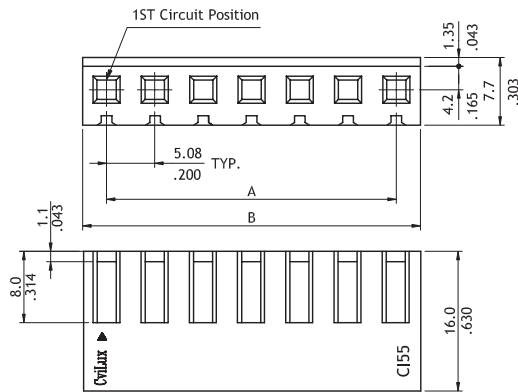

P/N:CI55\*\*S0000

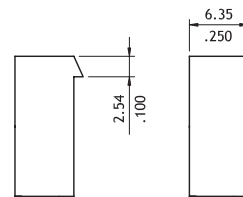

P/N:CI55\*\*S000R

Circuits	Dimension	
	A	B
2	5.08(.200)	10.08(.397)
3	10.16(.400)	15.16(.597)
4	15.24(.600)	20.24(.797)
5	20.32(.800)	25.32(.997)
6	25.40(1.00)	30.40(1.197)
7	30.48(1.20)	35.48(1.397)
8	35.56(1.40)	40.56(1.597)
9	40.64(1.60)	45.64(1.797)
10	45.72(1.80)	50.72(1.997)

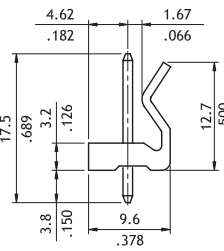
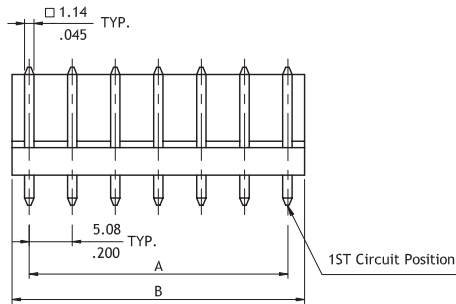

Circuits	Dimension	
	A	B
2	5.08(.200)	10.08(.397)
3	10.16(.400)	15.16(.597)
4	15.24(.600)	20.24(.797)
5	20.32(.800)	25.32(.997)
6	25.40(1.000)	30.40(1.197)
7	30.48(1.200)	35.48(1.397)
8	35.56(1.400)	40.56(1.597)
9	40.64(1.600)	45.64(1.797)
10	45.72(1.800)	50.72(1.997)

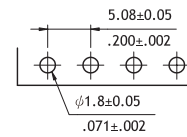
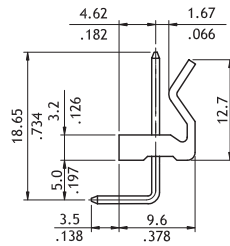
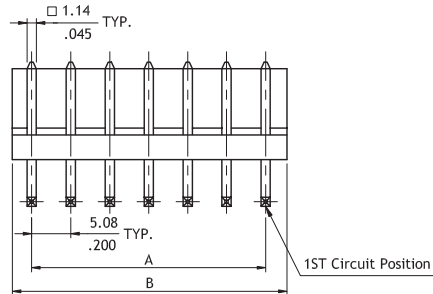

Recommended P.C. Board Layout

**Ordering Code**

① CI55 ② 10 ③ S ④ 0000

- ① Series No.
- ② No. of Circuits: 02 ~ 10
- ③ S = Housing
- ④ Other Options:  
0000 = Standard  
000R = Without Locking Ramp  
\*Special options consult manufacturer

① CI55 ② 10 ③ P ④ 1 ⑤ V ⑥ 00

- ① Series No
- ② No. of Circuits: 02 ~ 10
- ③ P = DIP Header
- ④ Plating Code: 1 = Tin over Nickel
- ⑤ Type: V = Straight ; H = Right Angle
- ⑥ Other Options: 00 = Standard  
\*Special options consult manufacturer

Connection Combinations of Power Connectors

CP

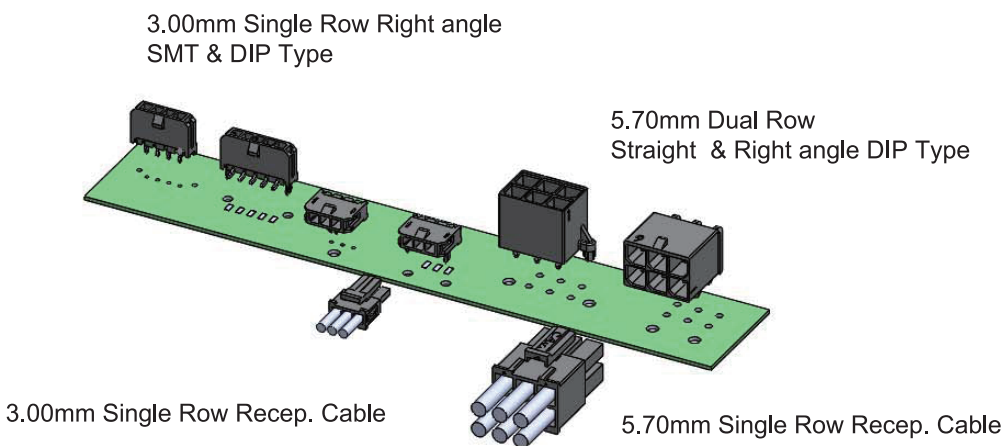
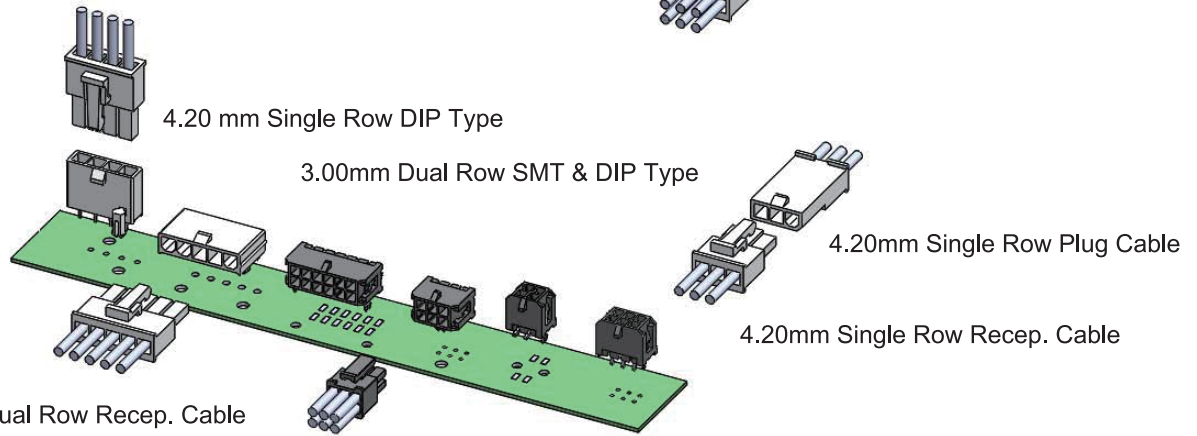
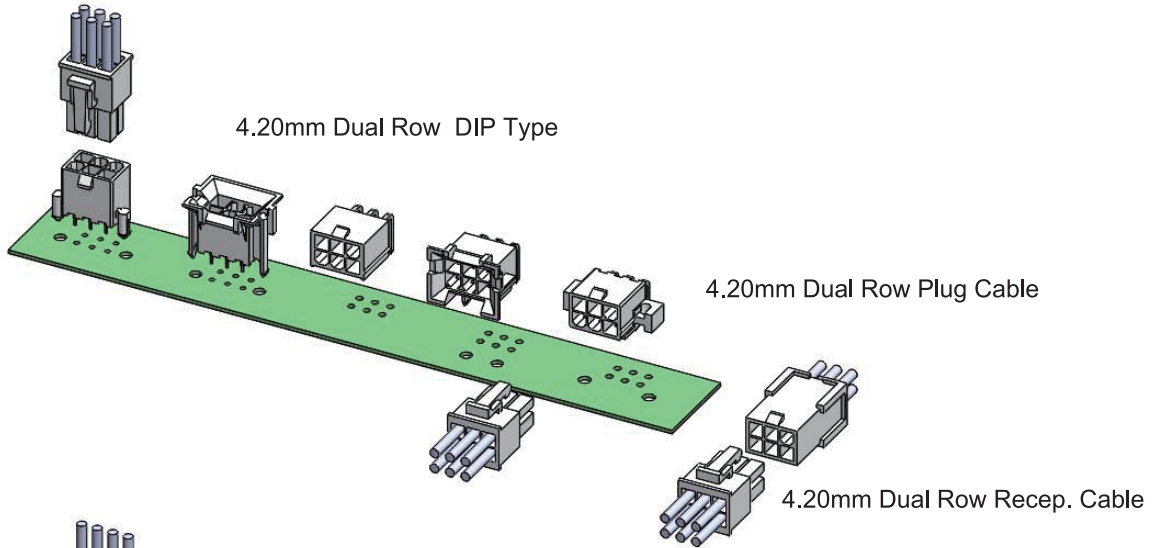

POWER CONNECTOR

## CP30 Series Battery Male Connectors

☉ Insulator: High Temperature plastic UL94V-0, Color Black

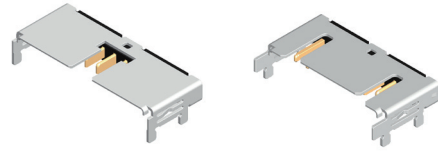

### CP30\*\*PAHSA-NH

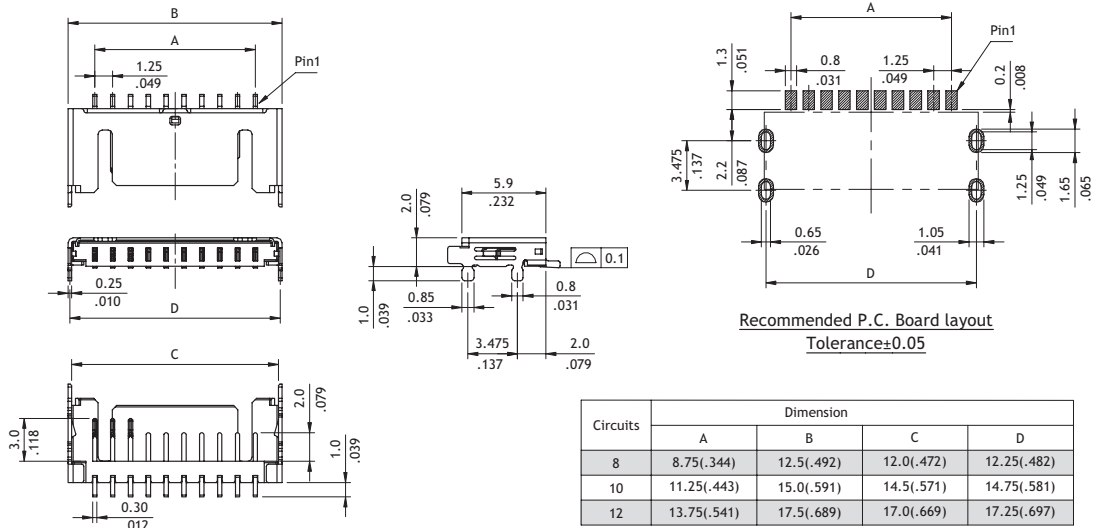

### CP3010PAHSB-NH

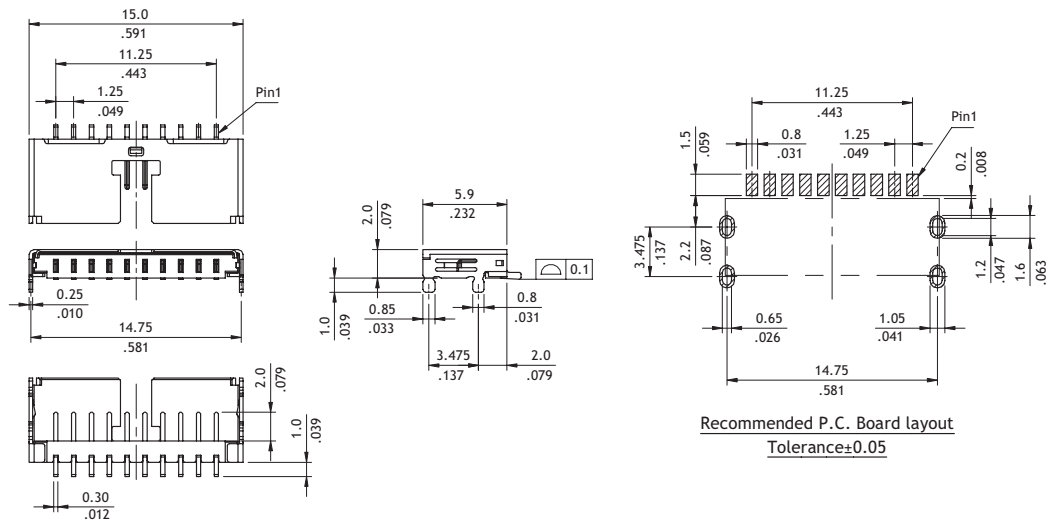

### Ordering Code

① ② ③ ④ ⑤ ⑥ ⑦ ⑧  
**CP30 10 P A H S A - NH**

- ① Series No.
- ② No. of Circuits: 08,10,12
- ③ P = Plug
- ④ Plating : A = Selective Gold flash over Nickel
- ⑤ Type : H = Right Angle
- ⑥ Mount Type : S = SMT Type
- ⑦ Other Option : A = With thru hole solder tab
- ⑧ NH= For Lead Free soldering process and Halogen-Free

① ② ③ ④ ⑤ ⑥ ⑦ ⑧  
**CP30 10 P A H S B - NH**

- ① Series No.
- ② No. of Circuits: 10
- ③ P = Plug
- ④ Plating : A = Selective Gold flash over Nickel
- ⑤ Type : H = Right Angle
- ⑥ Mount Type : S = SMT Type
- ⑦ Other Option : B = Type B
- ⑧ NH= For Lead Free soldering process and Halogen-Free

**CP30 Series Battery Male Connectors**

☉ Insulator: High Temperature plastic UL94V-0, Color Black

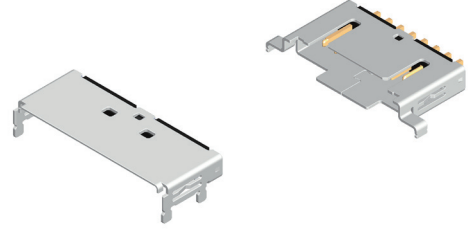

CP30\*\*PAHMC-NH

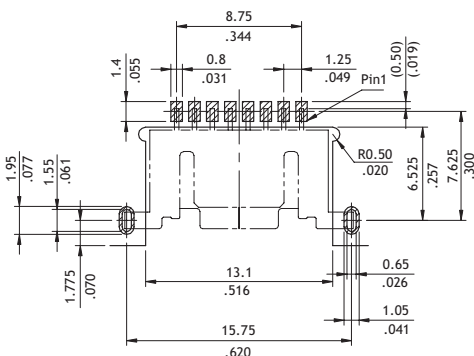
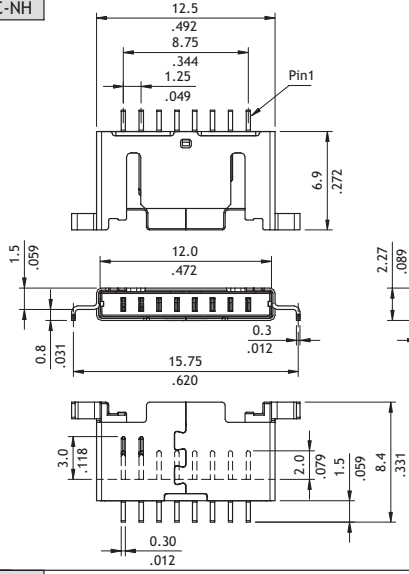

CP30\*\*PAHSE-NH

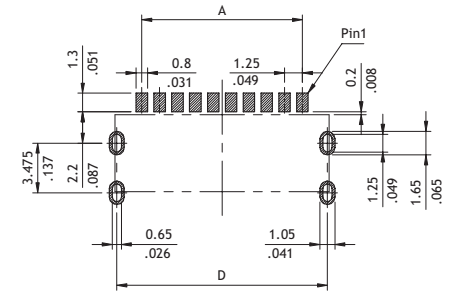
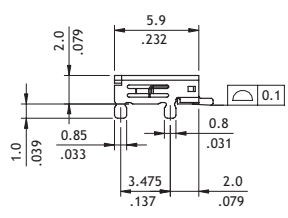
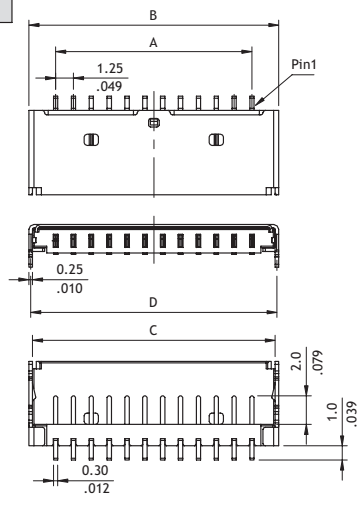

Circuits	Dimension			
	A	B	C	D
12	13.75(.541)	17.5(.689)	17.0(.669)	17.25(.697)
14	16.25(.640)	20.0(.787)	19.5(.768)	19.75(.778)

**Ordering Code**

① ② ③ ④ ⑤ ⑥ ⑦ ⑧  
**CP30 08 P A H M C - NH**

- ① Series No.
- ② No. of Circuits: 08
- ③ P = Plug
- ④ Plating : A = Selective Gold flash over Nickel
- ⑤ Type : H = Right Angle
- ⑥ Mount Type : M = Middle Mount Type
- ⑦ Other Option : C = Pin No.7~8 Power Pin
- ⑧ NH= For Lead Free soldering process and Halogen-Free

① ② ③ ④ ⑤ ⑥ ⑦ ⑧  
**CP30 12 P A H S E - NH**

- ① Series No.
- ② No. of Circuits: 12, 14
- ③ P = Plug
- ④ Plating : A = Selective Gold flash over Nickel
- ⑤ Type : H = Right Angle
- ⑥ Mount Type : S = SMT Type
- ⑦ Other Option : E = With through hole solder tab
- ⑧ NH= For Lead Free soldering process and Halogen-Free

CP

POWER CONNECTOR

**CP75 Series 1.50mm (.059) Board to Board Receptacle Connectors**

- ⊙ Locking slots provide secure mating
- ⊙ Fixed tabs provide PCB hold-down and strain-relief for SMT tails
- ⊙ Insulator: High Temperature plastic UL94V-0, Color Black
- ⊙ Mate with CP75 plug connector

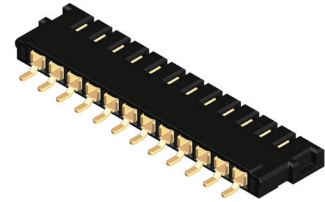

RoHS Compliant

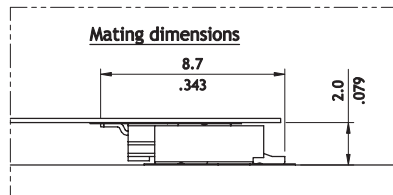
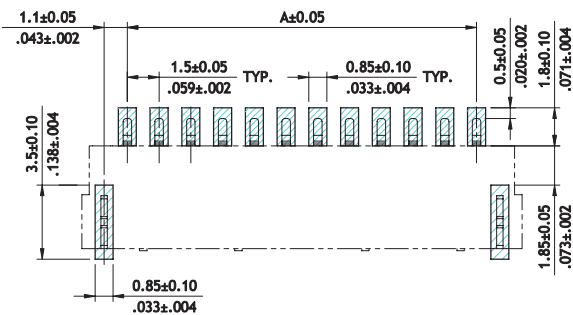
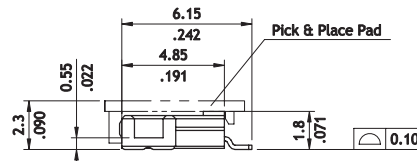
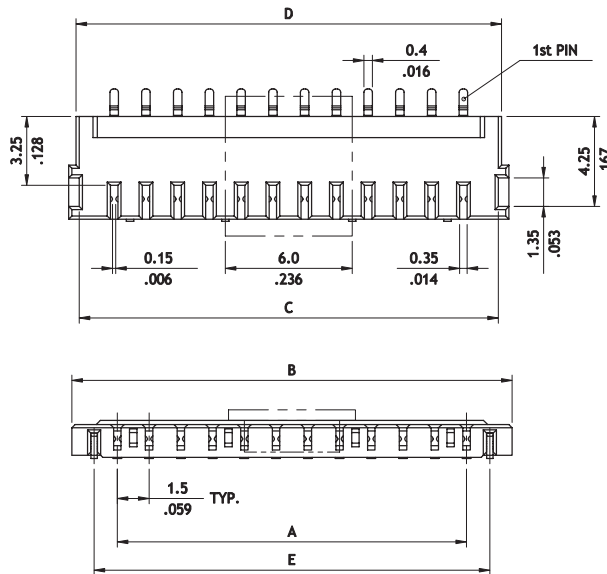

**Recommended P.C. Board Layout**

Circuits	Dimension				
	A	B	C	D	E
10	13.5(.531)	17.8(.701)	16.8(.661)	17.1(.673)	15.7(.618)
12	16.5(.650)	20.8(.819)	19.8(.780)	20.1(.791)	18.7(.736)

**Ordering Code**

① ② ③ ④ ⑤ ⑥ ⑦  
**CP75 10 M E S R0 - NH**

- ① Series No.
- ② No. of Circuits: 10, 12
- ③ M = SMT Type
- ④ Plating Code:  
 E = Contact: 10µ" Gold plated over Nickel  
 Soldertails: Gold flash plated over Nickel  
 G = Contact: 30µ" Gold plated over Nickel  
 Soldertails: Gold flash plated over Nickel
- ⑤ Type: S = Receptacle
- ⑥ Packing Option : R0 = Tape & Reel packing
- ⑦ NH= For Lead Free soldering process and Halogen-Free

**CP75 Series 1.50mm (.059) Board to Board Plug Connectors**

- ⊙ Locking slots provide secure mating
- ⊙ Fixed tabs provide PCB hold-down and strain-relief for SMT tails
- ⊙ Insulator: High Temperature plastic UL94V-0, Color Black
- ⊙ Mate with CP75 receptacle connector

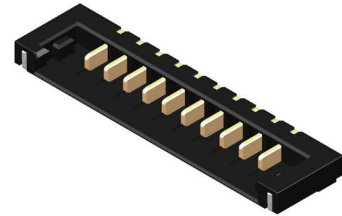

RoHS Compliant  

CP

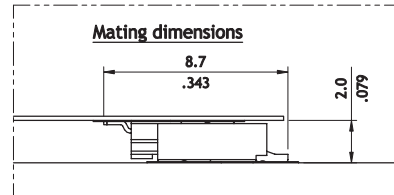
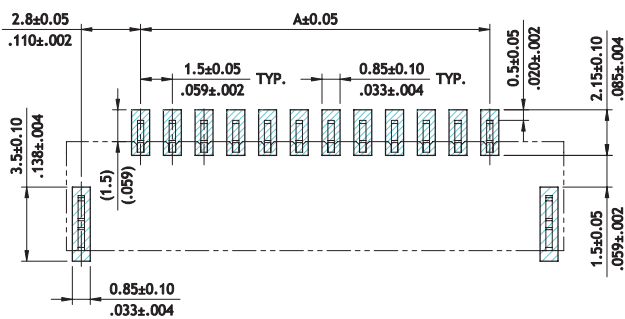
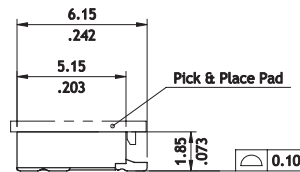
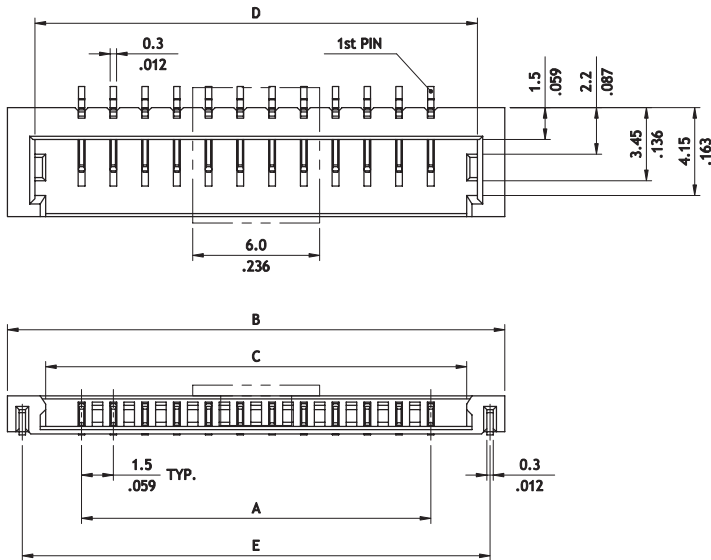

Recommended P.C. Board Layout

Circuits	Dimension				
	A	B	C	D	E
10	13.5(.531)	20.5(.807)	16.9(.665)	17.9(.705)	19.1(.752)
12	16.5(.650)	23.5(.925)	19.9(.783)	20.9(.823)	22.1(.870)

**Ordering Code**

① ② ③ ④ ⑤ ⑥ ⑦  
**CP75 10 M E P R0 - NH**

- ① Series No.
- ② No. of Circuits: 10, 12
- ③ M = SMT Type
- ④ Plating Code:  
 E = Contact: 10µ" Gold plated over Nickel  
 Soldertails: Gold flash plated over Nickel  
 G = Contact: 30µ" Gold plated over Nickel  
 Soldertails: Gold flash plated over Nickel
- ⑤ Type: P = Plug
- ⑥ Packing Option : R0 = Tape & Reel packing
- ⑦ NH= For Lead Free soldering process and Halogen-Free

**CP14 Series 1.50mm(.059") Single Row Side Entry SMT Headers**

- ⊙ Simplify manufacturing procedure
- ⊙ Reduce the Cost
- ⊙ FPC zero insertion force and high holding force
- ⊙ Insulation: High temperature plastic UL 94V-0, Color Black
- ⊙ With metal fixed tabs to secure connector in place

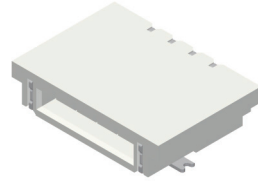

RoHS Compliant

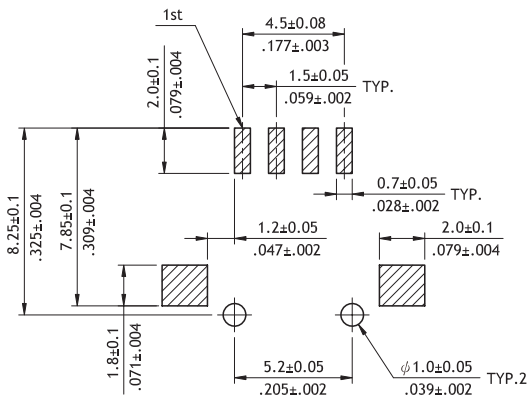
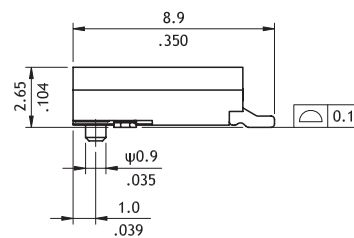
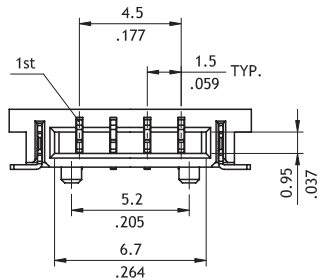
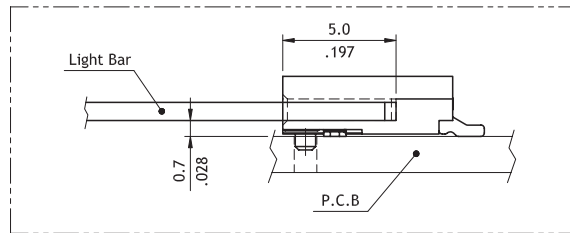
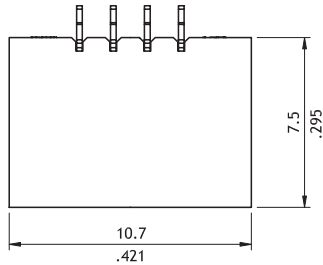

Recommended Connector PCB Layout

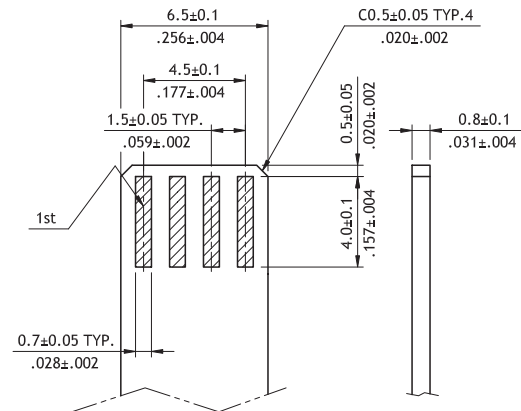

Recommended Light Bar PCB Layout

**Ordering Code**

① ② ③ ④ ⑤ ⑥ ⑦ ⑧  
**CP14 04 M 1 H R B - NH**

- ① Series No.
- ② No. of Circuits: 4  
\*Circuits not found above, please consult manufacturer
- ③ M = SMT Type
- ④ Plating Code : 1 = Matte Tin over Nickel

- ⑤ Type: H = Side Entry
- ⑥ Packing Options: R = Tape & Reel
- ⑦ Other Options: B = Upside Contact
- ⑧ NH = For Lead Free soldering process and Halogen-Free

CP15 Series 1.50mm(.069") SMT Headers

CP

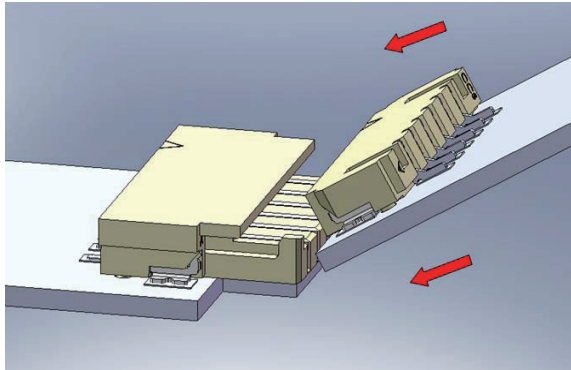

Step 1:  
The male header should be tilted during insertion.

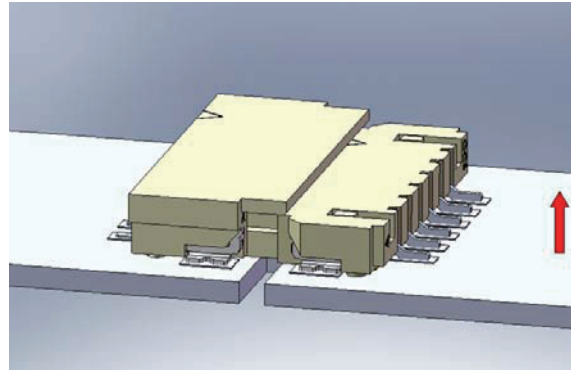

Step 1:  
Lift the male header up at 30° -60°.

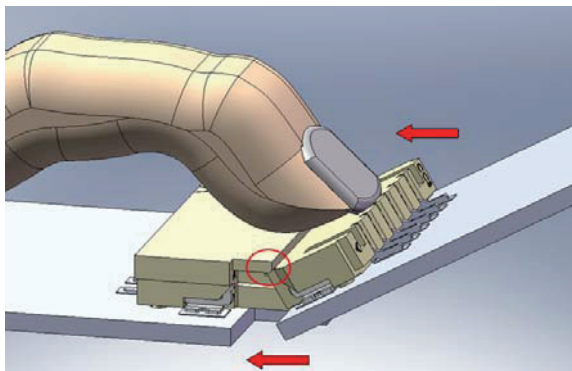

Step 2:  
Push the male header to the end. Make sure the male header is under the rib of female header by finger.

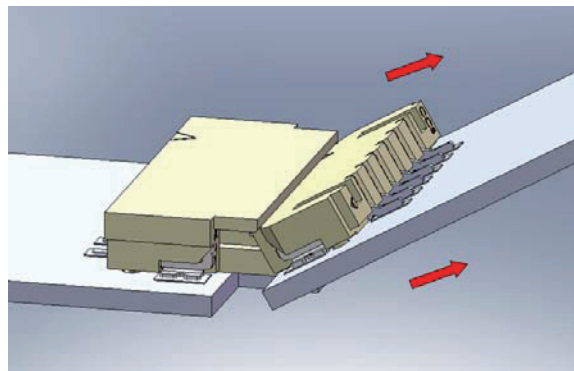

Step 2:  
Remove male header at an angle to finish the disconnection.

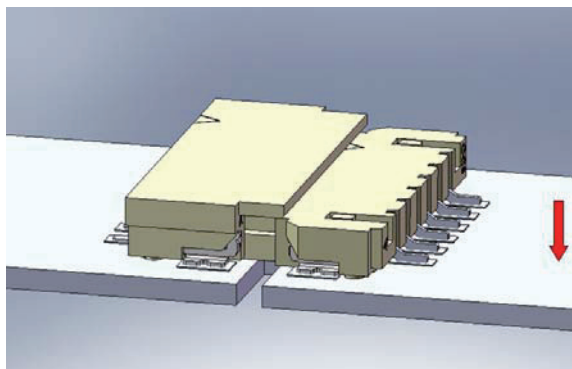

Step 3:  
Press down the male header down vertically to finish the connection.

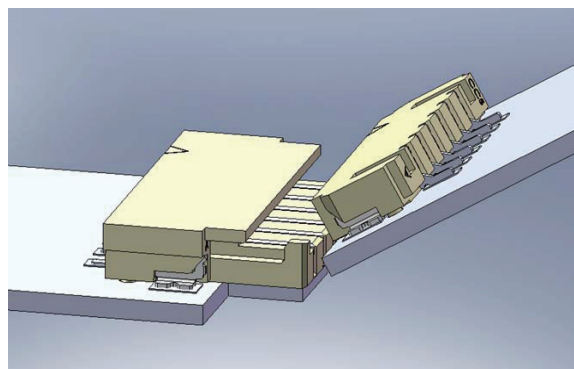

Step 3:  
Finish

**CP15 Series 1.50mm(.069") SMT Headers (Mating height 2.50mm)**

- ⊙ Simplify manufacturing procedure
- ⊙ Reduce the Cost
- ⊙ Insulator: High temperature plastic UL 94V-0
- ⊙ With metal fixed tabs to secure connector in place

RoHS Compliant

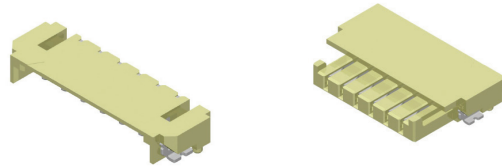

P/N CP15\*\*M1PR0-NH

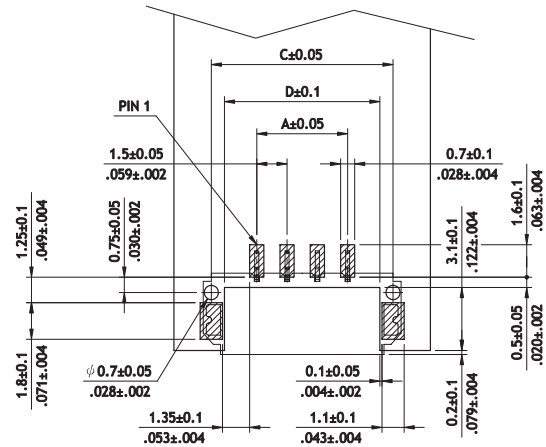
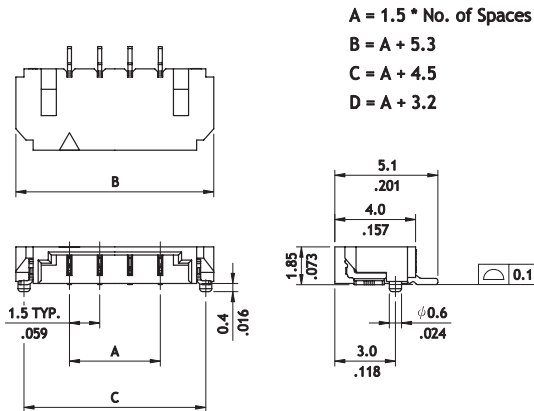

P/N CP15\*\*M1SR0-NH

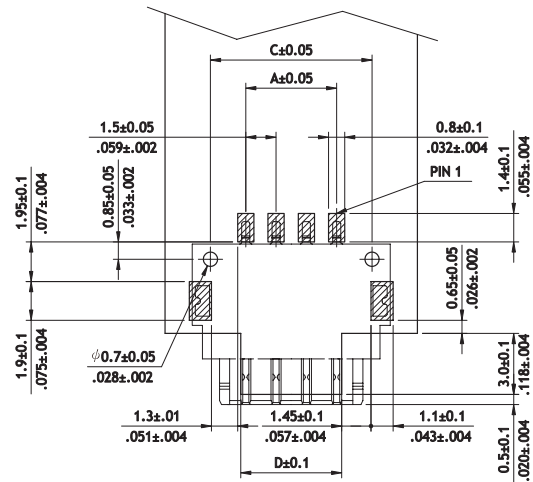
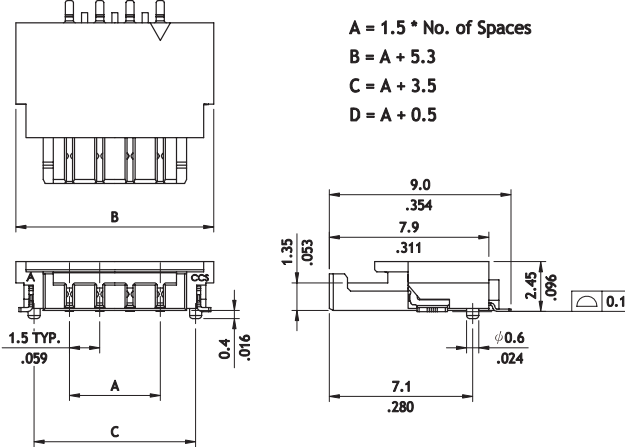

**Ordering Code**

① ② ③ ④ ⑤ ⑥ ⑦ ⑧  
**CP15 04 M 1 S R 0 - NH**

- ① Series No.
- ② No. of Circuits: 02 ~ 05 (Available in 3, 4, 5pin)  
\*Circuits not found above, please consult manufacturer
- ③ M = SMT Type
- ④ Plating Code :  
1 = Matte Tin over Nickel
- ⑤ Type: P = Plug  
S = Receptacle
- ⑥ Packing Options:  
R = Tape & Reel
- ⑦ Other Options:  
0 = Standard (Full of pin)  
1 = Omitted pin No.2 (3 pin)  
\*Special option consult manufacturer
- ⑧ NH = For Lead Free IR process and Halogen-Free

**CP15 Series 1.50mm(.069") SMT Headers (Mating height 3.0mm)**

- ⊙ With taller height, width and enhanced structure
- ⊙ Simplify manufacturing procedure
- ⊙ Reduce the cost
- ⊙ Insulator: High temperature plastic UL 94V-0
- ⊙ With metal fixed tabs to secure connector in place

RoHS Compliant  

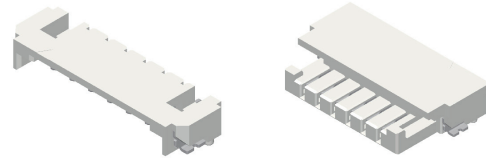

P/N CP15\*\*M1PRB-NH

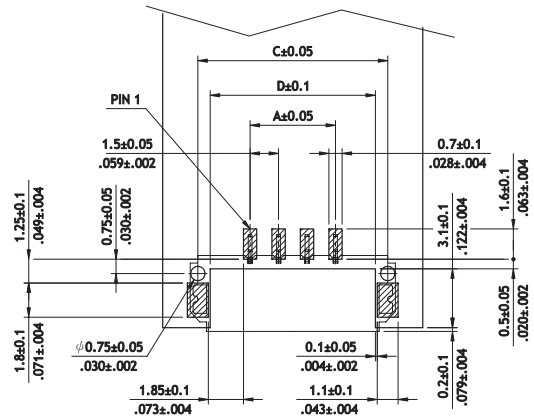
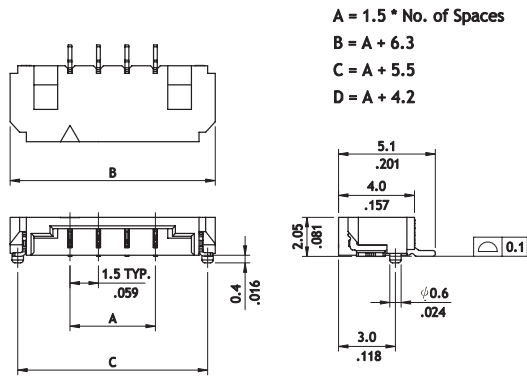

P/N CP15\*\*M1SRB-NH

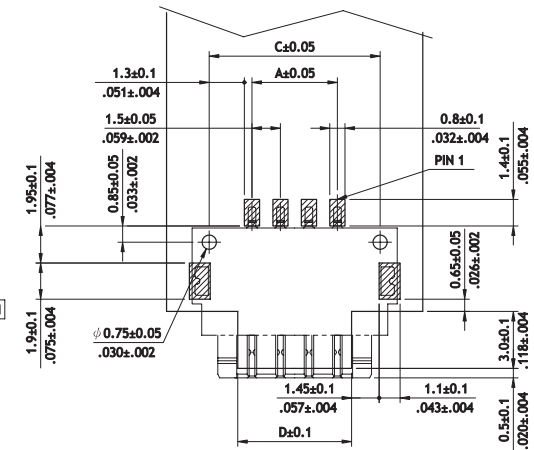
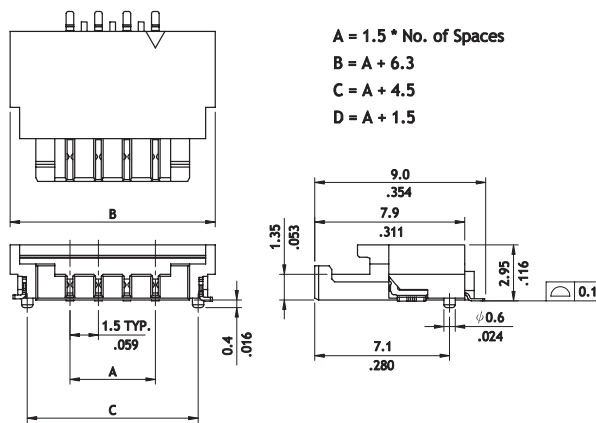

**Ordering Code**

① ② ③ ④ ⑤ ⑥ ⑦ ⑧  
**CP15 04 M 1 S R B - NH**

- ① Series No.
- ② No. of Circuits: 02 ~ 05(Available in 03, 04 pin)  
\*Circuits not found above, please consult manufacturer
- ③ M = SMT Type
- ④ Plating Code : 1 = Matte Tin over Nickel
- ⑤ Type: P = Plug S = Receptacle
- ⑥ Packing Options : R = Tape & Reel

- ⑦ Other Options:  
A = Omitted pin No.2 (3 pin)  
B = Standard (Full of pin)  
\*Special option consult manufacturer
- ⑧ NH = For Lead Free IR process and Halogen-Free

**CPB1 Series Waterproof Connectors**

- ⊙ Insulator: Polycarbonate UL 94 V-2 Color Nature
- ⊙ Contact : Copper Alloy
- ⊙ According to IEC 60529 IPX7
- ⊙ Wire to Wire connecting
- ⊙ Maximum applied current 15A for AWG 14

RoHS Compliant

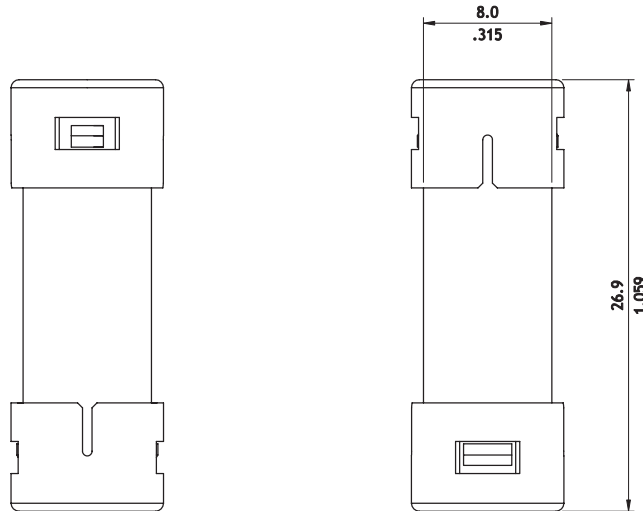
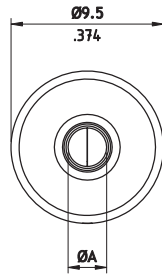
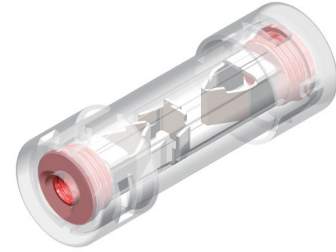

	DIM.A	Waterproof stopper color	Wire Range	Insulation Diameter	Single core wire Core Diameter	Multi-core wire Core Diameter
CPB101S1010-NH	1.70	Red	Awg18	2.00	1.02	1.20 max.
CPB101S1020-NH	2.00	Green	Awg16	2.25	1.29	1.35 max.
			Awg14	2.55	1.63	1.80 max.

Ordering Code	①	②	③	④	⑤	⑥	⑦
	CPB1	01	S	1	01	0	-NH
<p>① Series No.</p> <p>② No. of Circuits: 01</p> <p>③ S = Housing</p> <p>④ Plating Code : 1 = Tin over Nickel</p>	<p>⑤ DIM.A: 01= For Wire insulation O.D.=2.00mm 02= For Wire Insulation O.D.=2.25 and 2.55mm</p> <p>⑥ Option : 0 = Standard</p> <p>⑦ NH= For Lead Free soldering process and Halogen-Free</p>						

**CPB2 Series 2.00mm (.079) Waterproof Connectors**

- ⊙ Mate with CPB2 connector
- ⊙ Can be used with CPB2 Crimp Clip Receptacle terminal
- ⊙ Insulator : PBT UL94V-0, Nature Color
- ⊙ According to IEC 60529 IPX7

RoHS Compliance

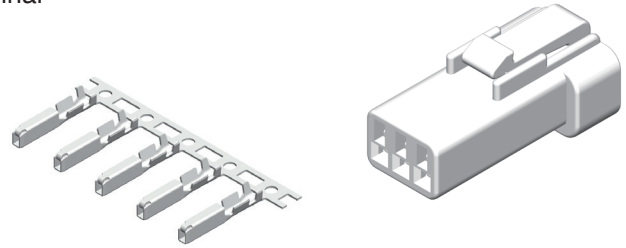

CP

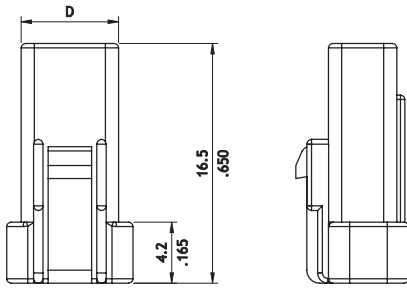
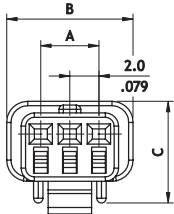

02-04 PIN

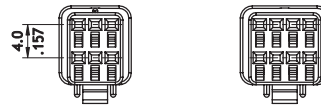
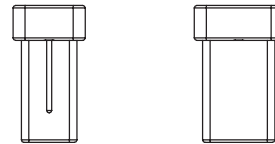

06 PIN      08 PIN

Circuits	Dimension			
	A	B	C	D
2	-	6.7(.264)	7.0(.276)	4.7(.185)
3	4.0(.157)	8.7(.343)	7.0(.276)	6.7(.264)
4	6.0(.236)	10.7(.421)	7.0(.276)	8.7(.343)
6	4.0(.157)	8.7(.343)	11.0(.433)	6.7(.264)
8	6.0(.236)	10.7(.421)	11.0(.433)	8.7(.343)

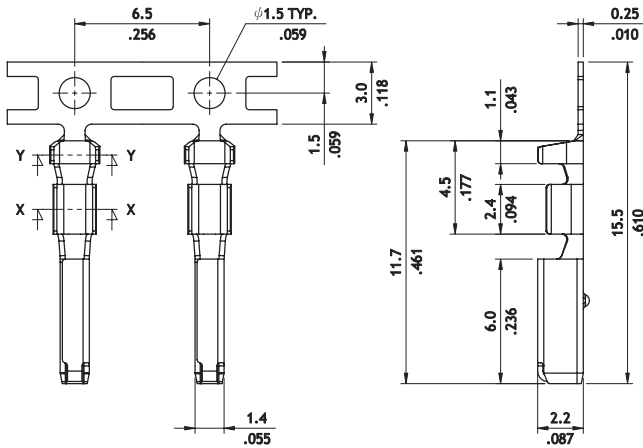

Wire Range	Insulation Diameter	Reel Qty
AWG #22-#26	1.4-1.7mm	10,000 PCS

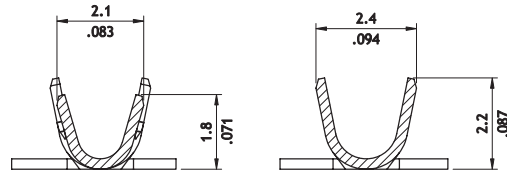

SEC. X-X

SEC. Y-Y

**Ordering Code**

① CPB2   ② 08   ③ S   ④ 0   ⑤ R   ⑥ 00

① CPB2   ② T02   ③ 1   ④ P   ⑤ ES

- ① Series No.
- ② No. of Circuits: 02 ,03 , 04 , 06 , 08
- ③ S = Receptacle
- ④ 0 = Single Row (2P, 3P, 4P only)  
D= Dual Row (6P , 8P , only)
- ⑤ R=Rubber Seal
- ⑥ Other Options: 00= Standard

- ① Series No.
- ② Type:  
T01 = AWG #22 ~ #26
- ③ Plating Code : 1 = Tin over Nickel

- ④ Material:  
P = Phosphor Bronze
- ⑤ ES= Receptacle Terminal

POWER CONNECTOR

**CPB2 Series 2.00mm (.079) Waterproof Connectors**

- ⊙ Mate with CPB2 connector
- ⊙ Can be used with CPB2 Crimp Clip Receptacle terminal
- ⊙ Insulator : PBT UL94V-0, Nature Color
- ⊙ According to IEC 60529 IPX7

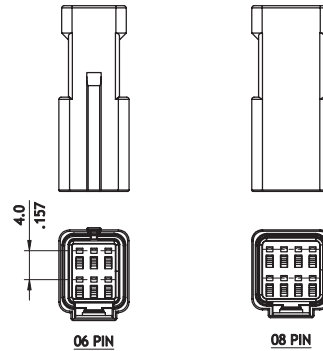
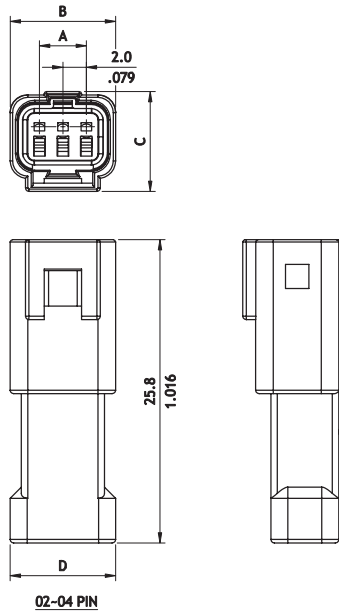
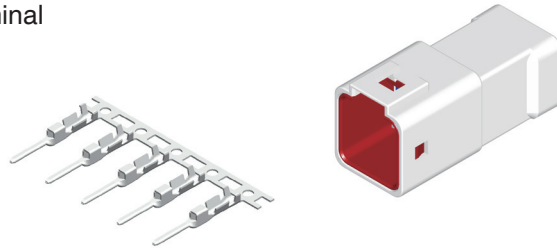

Circuits	Dimension			
	A	B	C	D
2	-	7.0(.276)	8.2(.323)	7.0(.276)
3	4.0(.157)	9.0(.354)	8.5(.335)	9.0(.354)
4	6.0(.236)	11.0(.433)	8.5(.335)	11.0(.433)
6	4.0(.157)	9.8(.386)	12.9(.508)	9.0(.354)
8	6.0(.236)	11.0(.433)	12.2(.480)	11.0(.433)

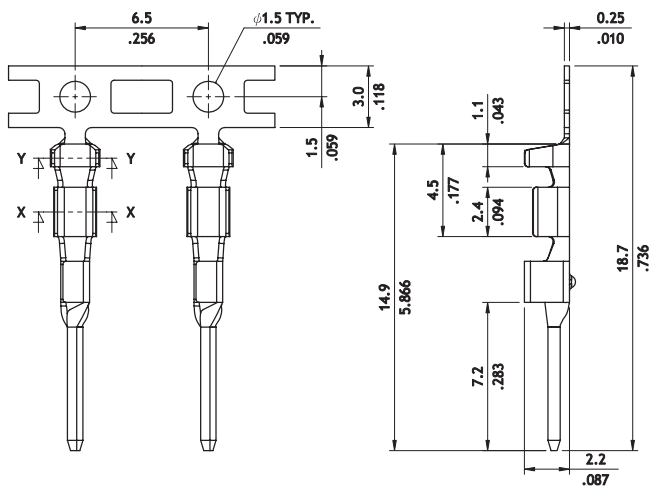

Wire Range	Insulation Diameter	Reel Qty
AWG #22-#26	1.4-1.7mm	10,000 PCS

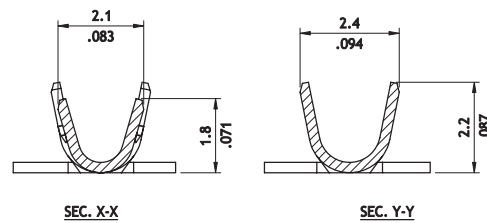

**Ordering Code**

① CPB2    ② 08    ③ P    ④ -0    ⑤ R    ⑥ 00

- ① Series No.
- ② No. of Circuits: 02 ,03 , 04 , 06 , 08
- ③ P = Plug Housing
- ④ 0 = Single Row (2P, 3P, 4P only)  
D= Dual Row (6P , 8P , only)
- ⑤ R=Rubber Seal
- ⑥ Other Options: 00= Standard

① CPB2    ② T02    ③ 1    ④ B    ⑤ P

- ① Series No.
- ② Type: T01 = AWG #22 ~ #26
- ③ Plating Code : 1 = Tin over Nickel
- ④ Material : B = Brass
- ⑤ PP= Plug Terminal

**CPB2 Series 2.00mm (.079) Waterproof Connectors**

- ⊙ Mate with CPB2 connector
- ⊙ Can be used with CPB2 Crimp Clip Receptacle terminal
- ⊙ Insulator : PBT UL94V-0, Nature Color
- ⊙ According to IEC 60529 IPX7



**RoHS** Compliant  

CP

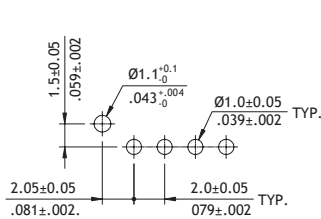
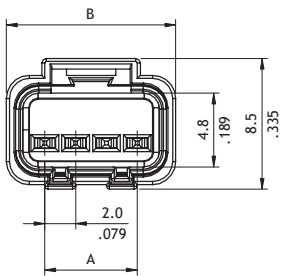

**Recommended P.C.B board Layout**  
02,03,04 PIN

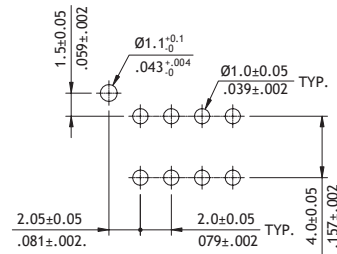

**Recommended P.C.B board Layout**  
06,08P IN

Circuits	Dimension	
	A	B
2	-	7.0(.276)
3	4.0(.157)	9.0(.354)
4	6.0(.236)	11.0(.433)
6	4.0(.157)	9.8(.386)
8	6.0(.236)	11.0(.433)

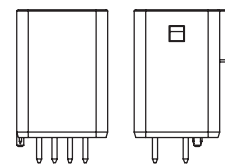
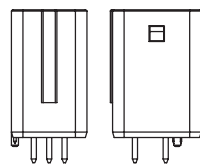
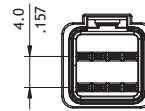
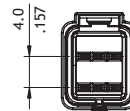
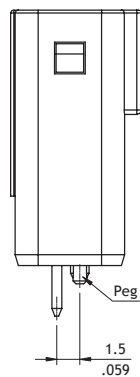
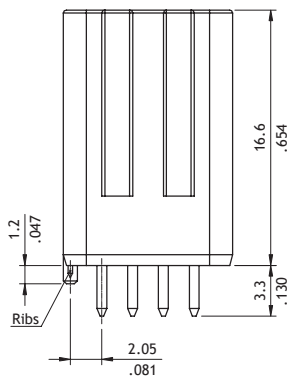

06 PIN

08 PIN

**Ordering Code**

① ② ③ ④ ⑤ ⑥ ⑦ ⑧  
**CPB2 04 S 1 V 0 A - NH**

- ① Series No.
- ② No. of Circuits: 04
- ③ S = Single Row
- ④ Plating Code : 1 = Tin over Nickel

- ⑤ V = Straight
- ⑥ 0 = DIP Type
- ⑦ Other Option :  
 0 = The Peg With Ribs (Standard)  
 A = Ther Peg Without Ribs
- ⑧ NH= For Lead Free soldering process and Halogen-Free

# CP25 Series 2.50mm(.098") Receptacle Battery Connectors

☉ Insulator: High Temperature plastic UL94V-0, Color Black

RoHS Compliant

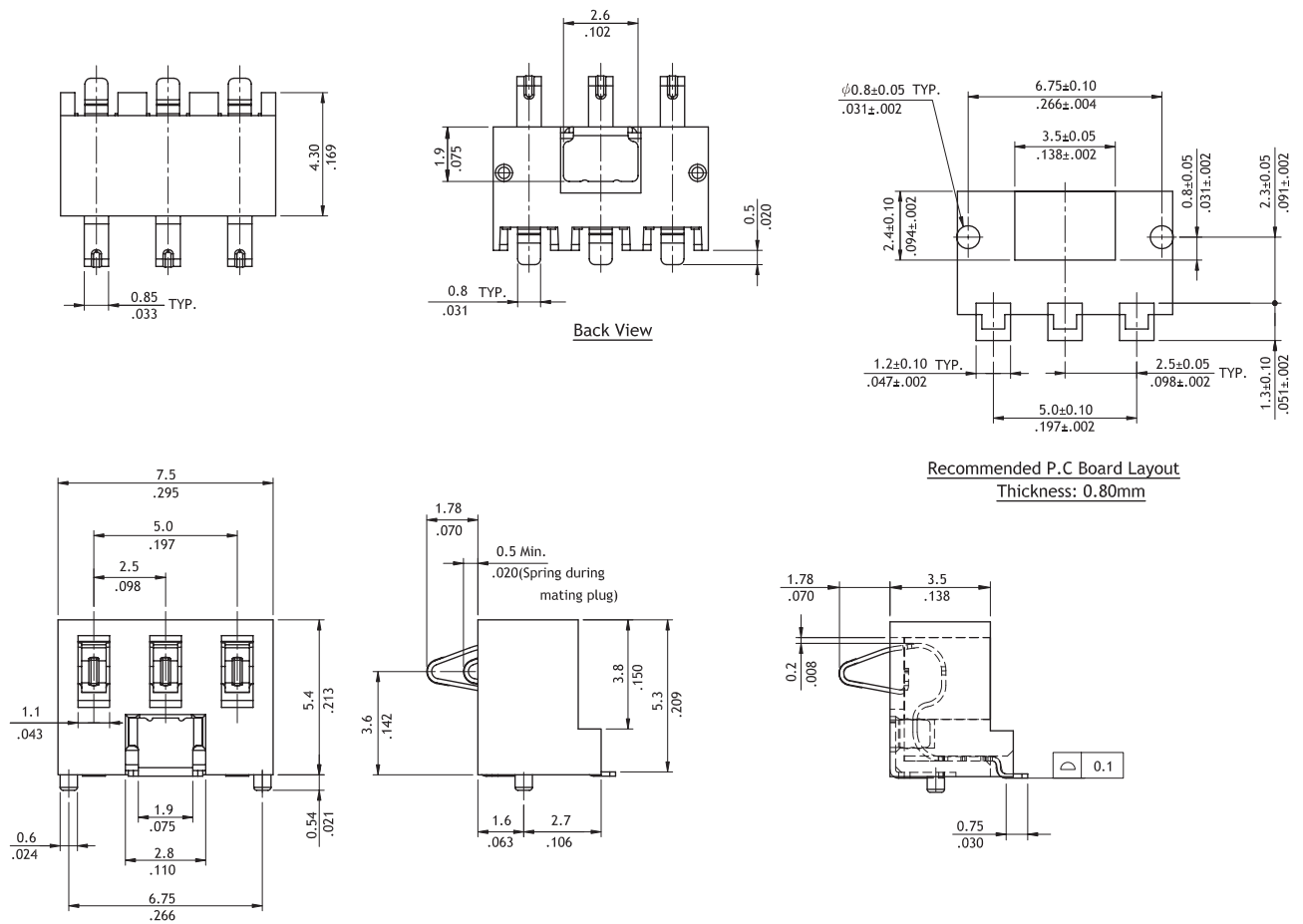
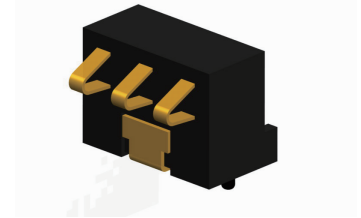

## Ordering Code

① ② ③ ④ ⑤ ⑥ ⑦  
**CP25 03 S 2 M R B**

- ① Series No.
- ② No. of Circuits: 3
- ③ S = Receptacle
- ④ Plating Code : 2 = Gold flash over Nickel

- ⑤ Type: M = SMT Type
- ⑥ Packing option: R= Tape & Reel
- ⑦ Other Options: B= Height = 5.4mm

**CP35 Series 3.00mm(.118") Single Row Housing Connectors**

- ⊙ With locking latch and mounting ears
- ⊙ Available in 2 through 12 circuits
- ⊙ Can be used with CP35 Crimp terminal
- ⊙ Thermal Polyester UL 94V-0, Color Black

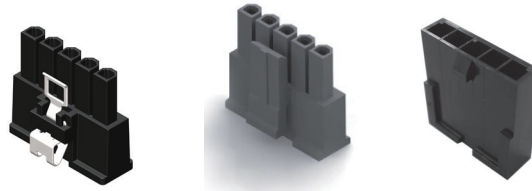

RoHS Compliant

CP

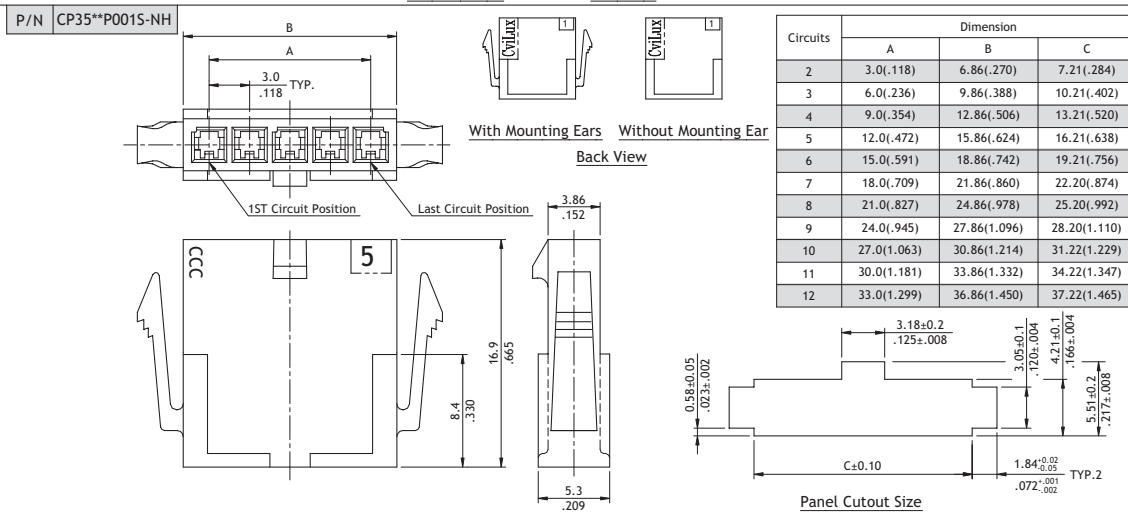
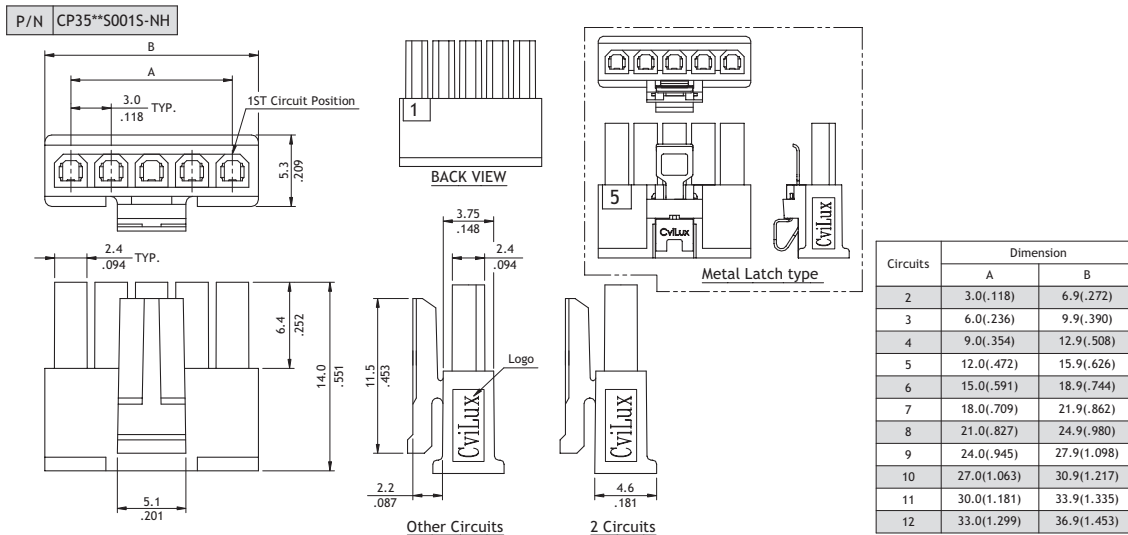

**Ordering Code**

① CP 35    ② 12    ③ S    ④ 001    ⑤ S - NH      ① CP 35    ② 12    ③ P    ④ 001    ⑤ S - NH

- ① Series No.
- ② No. of Circuits: 02 ~ 12
- ③ Type: S = Receptacle
- ④ Color: 001 = Color Black
- ⑤ Other Options: S = Single Row Type
- ⑥ NH = For Lead Free soldering process and Halogen-Free

- ① Series No.
- ② No. of Circuits: 02 ~ 12
- ③ Type: P = Plug
- ④ Options:  
0 = With mounting ears  
R = Without mounting ears

- ⑤ Color: 01 = Color Black
- ⑥ Other Options : S = Single Row Type  
\*Special options consult manufacturer
- ⑦ NH = For Lead Free soldering process and Halogen-Free

POWER CONNECTOR

# CP35 Series 3.00mm(.118") Single Row Board Mount Headers

- ⊙ Mates with CP35 Connector
- ⊙ Shrouded header with PCB mounting pegs or board locks
- ⊙ Available straight and right angle solder Tails

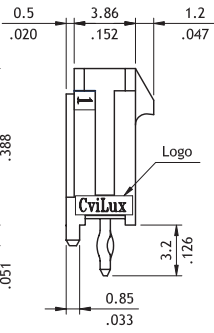
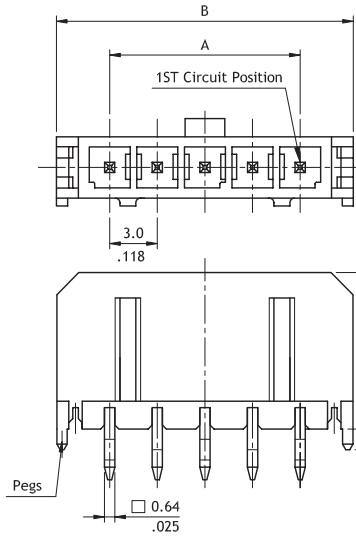
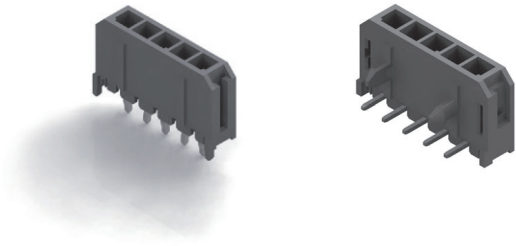

Circuits	Dimension	
	A	B
2	3.0(.118)	9.65(.380)
3	6.0(.236)	12.65(.498)
4	9.0(.354)	15.65(.616)
5	12.0(.472)	18.65(.734)
6	15.0(.591)	21.65(.852)
7	18.0(.709)	24.65(.970)
8	21.0(.827)	27.65(1.089)
9	24.0(.945)	30.65(1.207)
10	27.0(1.063)	33.65(1.325)
11	30.0(1.181)	36.65(1.443)
12	33.0(1.299)	39.65(1.561)

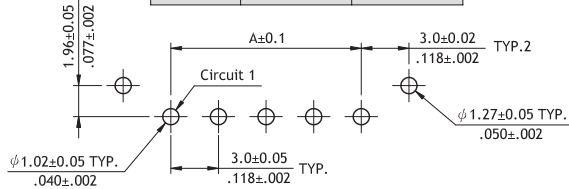

Recommended P.C. Board layout

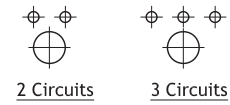
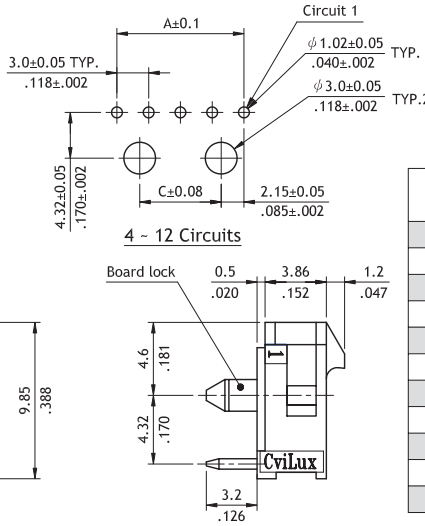
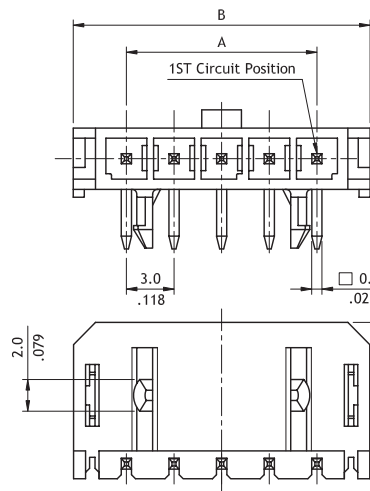

Circuits	Dimension		
	A	B	C
2	3.0(.118)	9.65(.380)	—
3	6.0(.236)	12.65(.498)	—
4	9.0(.354)	15.65(.616)	4.7(.185)
5	12.0(.472)	18.65(.734)	7.7(.303)
6	15.0(.591)	21.65(.852)	10.7(.421)
7	18.0(.709)	24.65(.970)	13.7(.539)
8	21.0(.827)	27.65(1.089)	16.7(.657)
9	24.0(.945)	30.65(1.207)	19.7(.776)
10	27.0(1.063)	33.65(1.325)	22.7(.894)
11	30.0(1.181)	36.65(1.443)	25.7(1.012)
12	33.0(1.299)	39.65(1.561)	28.7(1.130)

**Ordering Code**

①
②
③
④
⑤
⑥
⑦
⑧
⑨

CP35 12 P 1 V 0 0 - S - NH

① Series No.

② No. of Circuits: 02 ~12

③ P = Plug

④ Plating Code : 1 = Matte Tin over Nickel  
\*Optional plating available but MOQ requested

⑤ Contact Type : V = Straight , H = Right Angle

⑥ Mount Type : 0 = DIP Type

⑦ Other Options:  
0 = With pegs (Straight)  
0 = With plastic board lock (Right Angle)

⑧ S= Single Row Header

⑨ NH = For Lead Free soldering process and Halogen-Free

**CP35 Series 3.00mm (.118") Single Row Side Entry SMT Headers**

- ⊙ Mates with CP35 Connector
- ⊙ Shrouded header with PCB board locks or fixed tabs
- ⊙ High temperature plastic for SMT process

RoHS Compliant 

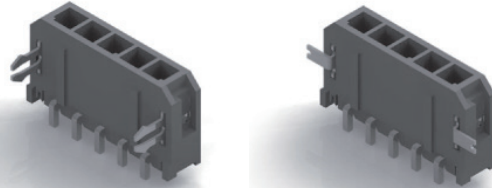

CP

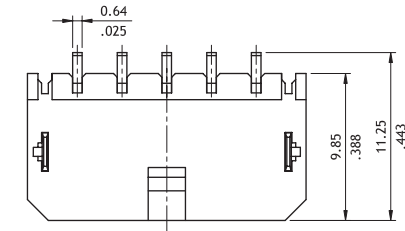

Circuits	Dimension	
	A	B
2	3.0(.118)	9.65(.380)
3	6.0(.236)	12.65(.498)
4	9.0(.354)	15.65(.616)
5	12.0(.472)	18.65(.734)
6	15.0(.591)	21.65(.852)
7	18.0(.709)	24.65(.970)
8	21.0(.827)	27.65(1.089)
9	24.0(.945)	30.65(1.207)
10	27.0(1.063)	33.65(1.325)
11	30.0(1.181)	36.65(1.443)
12	33.0(1.299)	39.65(1.561)

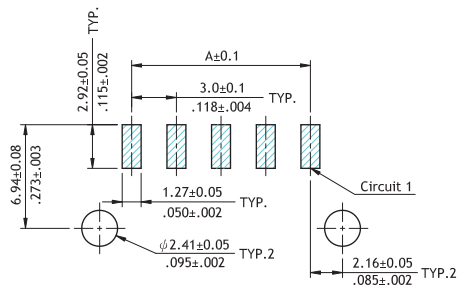
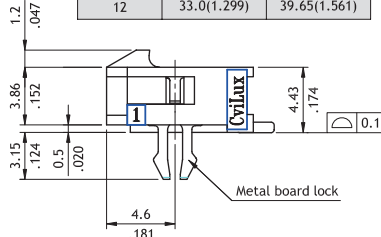
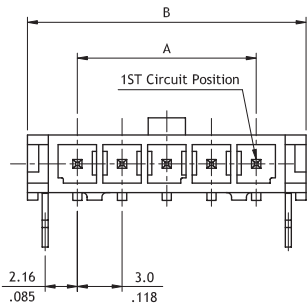

Recommended P.C. Board Layout

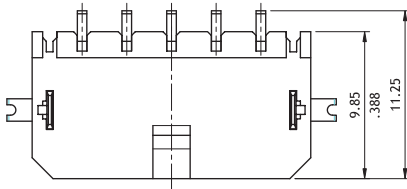

Circuits	Dimension	
	A	B
2	3.0(.118)	9.65(.380)
3	6.0(.236)	12.65(.498)
4	9.0(.354)	15.65(.616)
5	12.0(.472)	18.65(.734)
6	15.0(.591)	21.65(.852)
7	18.0(.709)	24.65(.970)
8	21.0(.827)	27.65(1.089)
9	24.0(.945)	30.65(1.207)
10	27.0(1.063)	33.65(1.325)
11	30.0(1.181)	36.65(1.443)
12	33.0(1.299)	39.65(1.561)

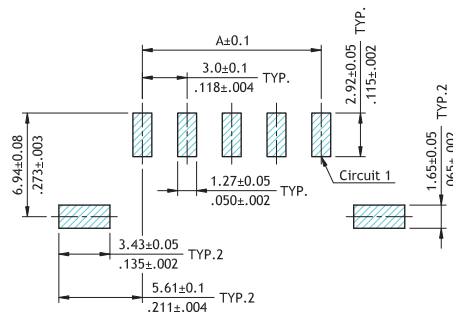
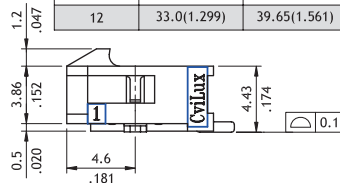
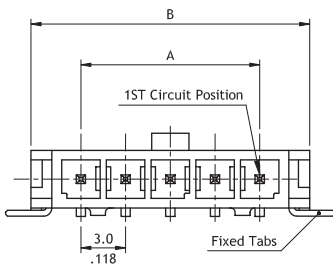

Recommended P.C. Board Layout

**Ordering Code**

① ② ③ ④ ⑤ ⑥ ⑦ ⑧ ⑨  
**CP35 12 P 1 H S 0 - S - NH**

- ① Series No.
- ② No. of Circuits: 02 ~ 12
- ③ P = Plug
- ④ Plating Code : 1 = Matte Tin over Nickel  
 \*Optional plating available but MOQ requested
- ⑤ Contact Type: H = Side Entry
- ⑥ Mount Type: S = SMT Type
- ⑦ Other Options:  
 0 = With Metal board lock  
 T = With Fixed Tabs (Available for Tape & Reel)
- ⑧ S= Single Row Header
- ⑨ NH = For Lead Free soldering process and Halogen-Free

**CP35 Series 3.00mm(.118") Single Row Side Entry SMT Headers**

- ⊙ Mates with CP35 Connector
- ⊙ Shrouded header with board locks
- ⊙ High temperature plastic for SMT process

RoHS Compliant

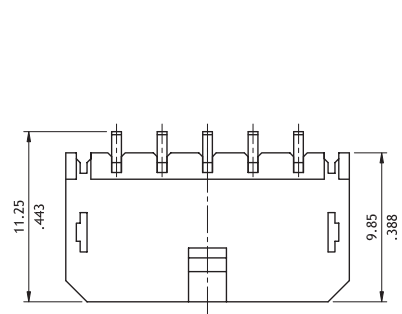
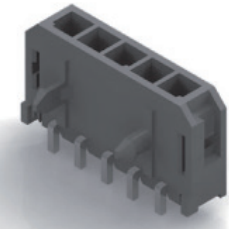

Circuits	Dimension		
	A	B	C
2	3.0(.118)	9.65(.380)	—
3	6.0(.236)	12.65(.498)	—
4	9.0(.354)	15.65(.616)	4.7(.185)
5	12.0(.472)	18.65(.734)	7.7(.303)
6	15.0(.591)	21.65(.852)	10.7(.421)
7	18.0(.709)	24.65(.970)	13.7(.539)
8	21.0(.827)	27.65(1.089)	16.7(.657)
9	24.0(.945)	30.65(1.207)	19.7(.776)
10	27.0(1.063)	33.65(1.325)	22.7(.894)
11	30.0(1.181)	36.65(1.443)	25.7(1.012)
12	33.0(1.299)	39.65(1.561)	28.7(1.130)

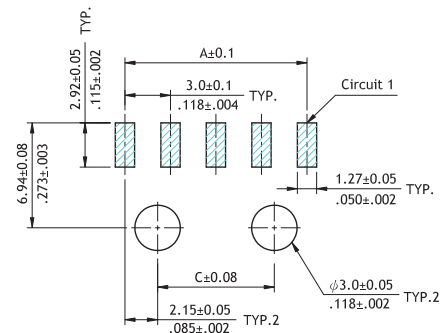
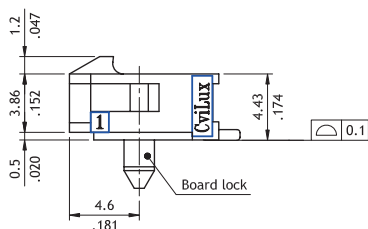
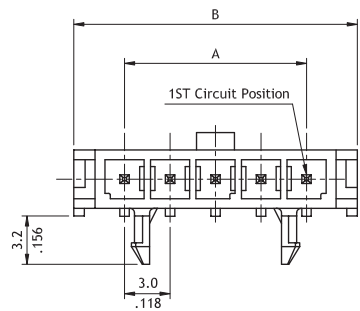
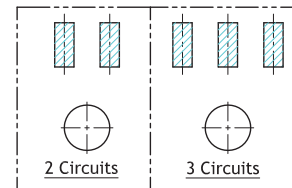

Recommended P.C. Board Layout

**Ordering Code**

① CP ② 35 ③ 12 ④ P ⑤ 1 ⑥ H ⑦ S ⑧ P - S - NH ⑨

- ① Series No.
- ② No. of Circuits: 02 ~ 12
- ③ P = Plug
- ④ Plating Code : 1 = Matte Tin over Nickel  
\*Optional plating available but MOQ requested
- ⑤ Contact Type: H = Side Entry
- ⑥ Mount Type: S = SMT Type
- ⑦ Other Options:  
P = With plastic board lock
- ⑧ S= Single Row Header
- ⑨ NH = For Lead Free soldering process and Halogen-Free

**CP35 Series 3.00mm(.118") Single Row Top Entry SMT Headers**

- ⊙ Mates with CP35 Connector
- ⊙ Shrouded header with board locks or fixed tabs.
- ⊙ With metal pick and place Pad
- ⊙ High temperature plastic for SMT process

RoHS Compliant 

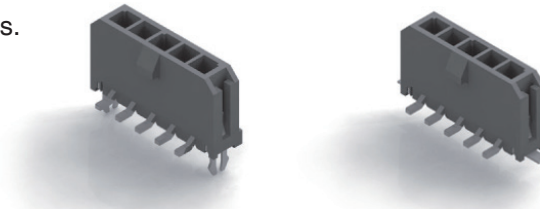

CP

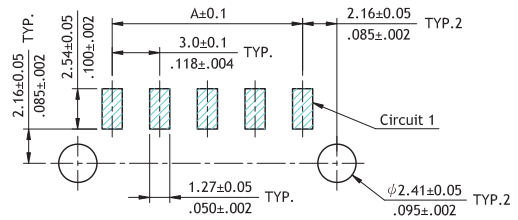
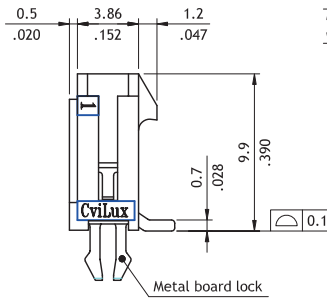
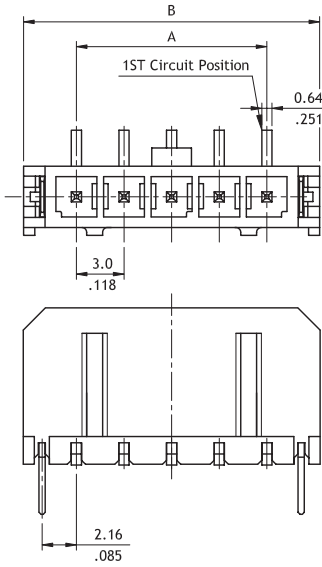

Recommended P.C. Board Layout

Circuits	Dimension	
	A	B
2	3.0(.118)	9.65(.380)
3	6.0(.236)	12.65(.498)
4	9.0(.354)	15.65(.616)
5	12.0(.472)	18.65(.734)
6	15.0(.591)	21.65(.852)
7	18.0(.709)	24.65(.970)
8	21.0(.827)	27.65(1.089)
9	24.0(.945)	30.65(1.207)
10	27.0(1.063)	33.65(1.325)
11	30.0(1.181)	36.65(1.443)
12	33.0(1.299)	39.65(1.561)

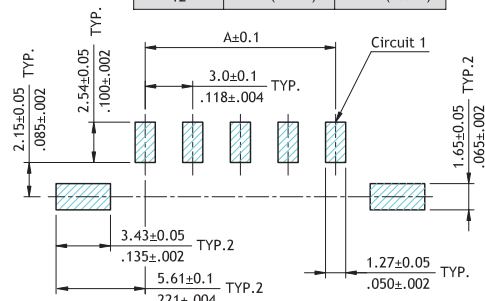
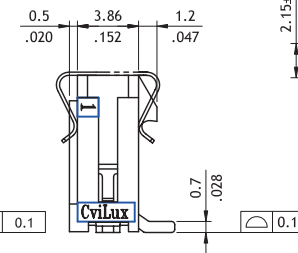
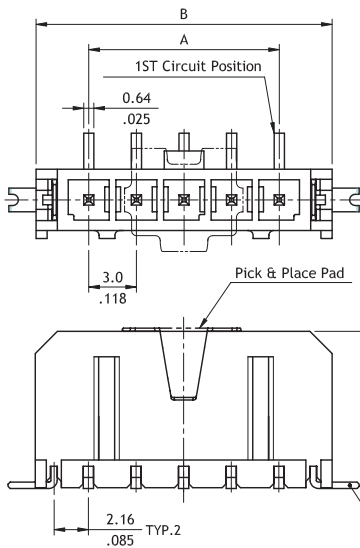

Recommended P.C. Board Layout

**Ordering Code**

① ② ③ ④ ⑤ ⑥ ⑦ ⑧ ⑨  
**CP35 12 P 1 V S 0 - S - NH**

- ① Series No.
- ② No. of Circuits: 02 ~12
- ③ P = Plug
- ④ Plating Code : 1 = Matte Tin over Nickel  
 \*Optional plating available but MOQ requested
- ⑤ Contact Type: V = Top Entry
- ⑥ Mount Type: S = SMT Type
- ⑦ Other Options:  
 0 = With Metal board locks  
 T = With Fixed Tabs (Available for Tape & Reel)
- ⑧ S= Single Row Header
- ⑨ NH = For Lead Free soldering process and Halogen-Free

POWER CONNECTOR

## CP35 Series 3.00mm(.118") Dual Row Receptacle Connectors

- ⊙ With locking latch
- ⊙ Available in 2 through 24 circuits
- ⊙ Can be used with CP35 Crimp Terminal
- ⊙ Terminal accommodated AWG #20 ~ #30

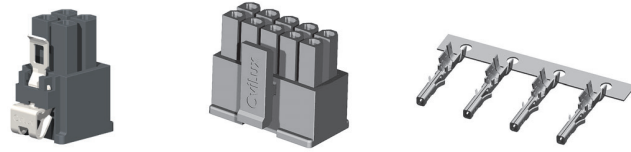

RoHS Compliant

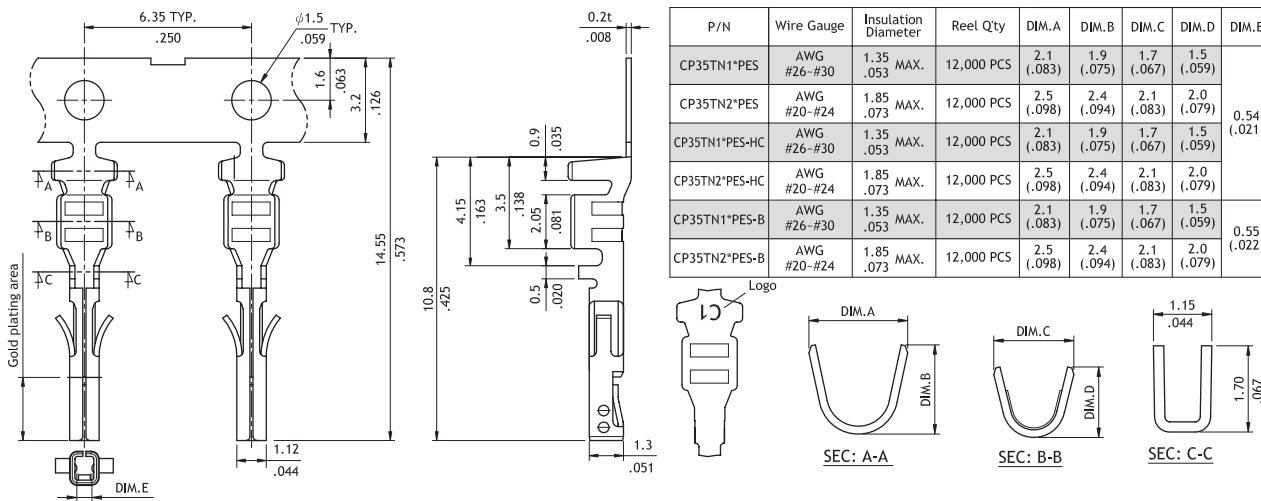
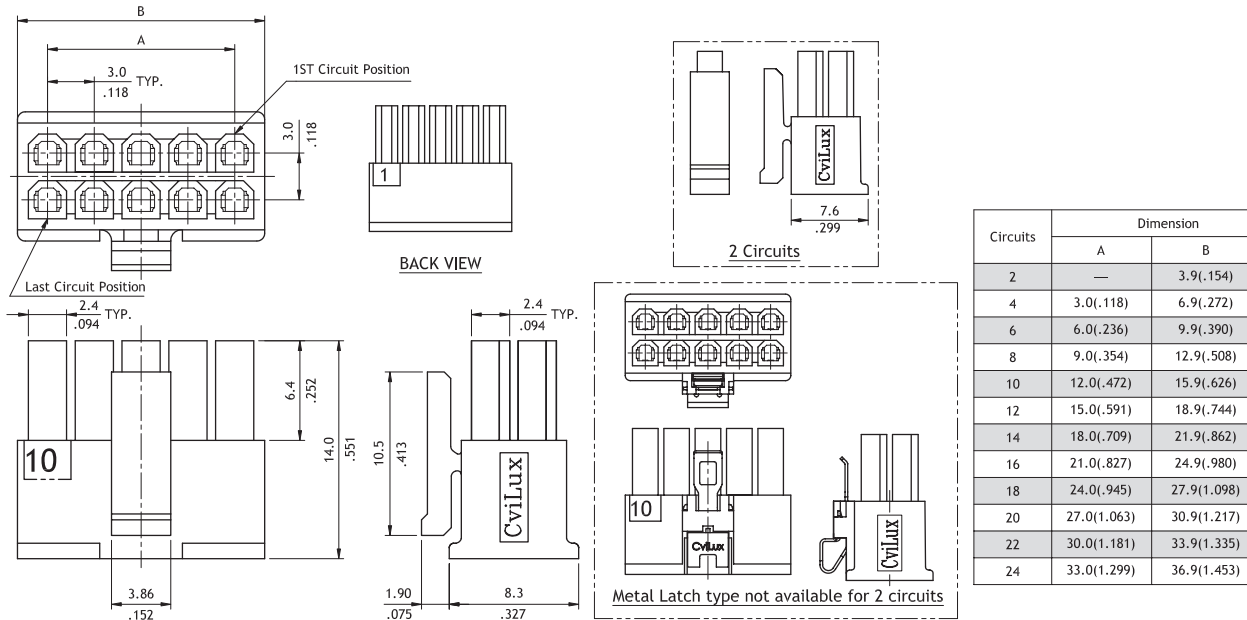

### Ordering Code

- |              |                            |                  |   |                          |  |  |              |   |   |                                    |   |
|--------------|----------------------------|------------------|---|--------------------------|--|--|--------------|---|---|------------------------------------|---|
| ①            | ②                          | ③                | ④   | ⑤                        | ⑥  | ⑦  | ①            | ②   | ③   | ④                                  | ⑤   |
| <b>CP35</b>  | <b>24</b>                  | <b>S</b>         | <b>00</b>                                       | <b>10</b>                | <b>-NH</b>   |  | <b>CP35</b>  | <b>TN2</b>  | <b>1</b>  | <b>P</b>                           | <b>ES</b>   |
| ① Series No. | ② No. of Circuits: 02 ~ 24 | ③ S = Receptacle | ④ Type: 00 = Standard,<br>ML = Metal Latch Type | ⑤ Color: 1 = Color Black | ⑥ Other Options: 0 = Standard<br>*Special options consult manufacturer | ⑦ NH = For Lead Free soldering process<br>and Halogen-Free | ① Series No. | ② Wire Range:<br>TN1 = AWG #26 ~ #30<br>TN2 = AWG #20 ~ #24 | ③ Plating Code :<br>1 = Tin over Nickel<br>A = Selective Gold flash over Nickel<br>*Optional plating available<br>but MOQ requested | ④ Material:<br>P = Phosphor Bronze | ⑤ Style:<br>ES = Receptacle Terminal<br>ES-B = Receptacle Terminal<br>(Low insertion Force)<br>ES-HC =<br>For high current required |

**CP35 Series 3.00mm(.118") Dual Row Plug Connectors**

- ⊙ With mounting ears
- ⊙ Available in 2 through 24 circuits
- ⊙ Can be used with CP35 Crimp terminal
- ⊙ Accommodated AWG #20 ~ #30

RoHS Compliant



CP

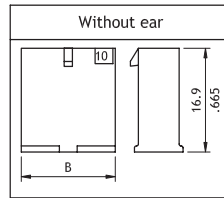
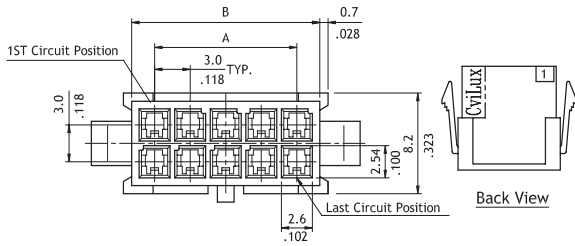

Circuits	Dimension		
	A	B	C
2	—	3.9(.154)	4.09(.161)
4	3.0(.118)	6.9(.272)	7.09(.279)
6	6.0(.236)	9.9(.390)	10.08(.397)
8	9.0(.354)	12.9(.508)	13.08(.515)
10	12.0(.472)	15.9(.626)	16.06(.633)
12	15.0(.591)	18.9(.744)	19.08(.751)
14	18.0(.709)	21.9(.862)	22.07(.869)
16	21.0(.827)	24.9(.980)	25.07(.967)
18	24.0(.945)	27.9(1.098)	28.07(1.105)
20	27.0(1.063)	30.9(1.217)	31.06(1.223)
22	30.0(1.181)	33.9(1.335)	34.06(1.341)
24	33.0(1.299)	36.9(1.453)	37.06(1.459)

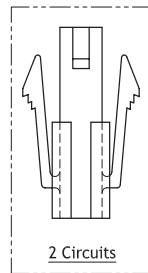
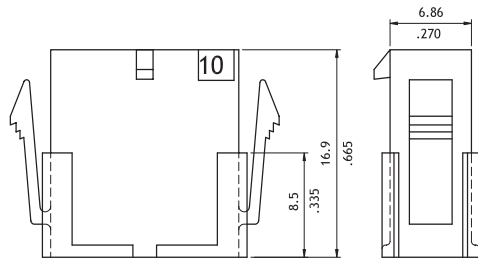

Panel Cutout Size

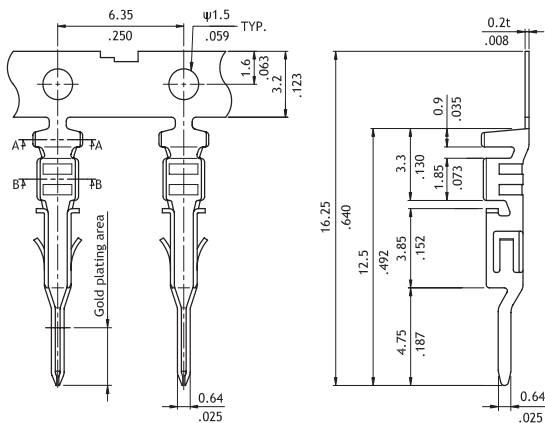

P/N	Wire Gauge	Insulation Diameter	Reel Q'ty	DIM.A	DIM.B	DIM.C	DIM.D
CP35TN1*PEP	AWG #26-#30	1.35 .053 MAX.	12,000 PCS	2.1 (.083)	1.9 (.075)	1.7 (.067)	1.5 (.059)
CP35TN2*PEP	AWG #20-#24	1.85 .073 MAX.	12,000 PCS	2.5 (.098)	2.4 (.094)	2.1 (.083)	2.0 (.079)

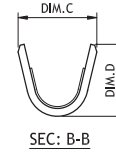
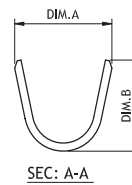

**Ordering Code**

① CP35    ② 24    ③ P    ④ 001    ⑤ 0 - NH    ① CP35    ② TN2    ③ 1    ④ P    ⑤ EP

- ① Series No.
- ② No. of Circuits: 02 ~24
- ③ P = Plug
- ④ Color: 001 = Color Black
- ⑤ Other Options:  
0 = Standard ; B = Without Ear
- ⑥ NH = For Lead Free soldering process and Halogen-Free

- ① Series No.
- ② Wire Range :  
TN1 = AWG #26 ~ #30  
TN2 = AWG #20 ~ #24
- ③ Plating Code :  
1 = Tin over Nickel  
A = Selective Gold flash over Nickel

- ④ Material:  
P = Phosphor Bronze
- ⑤ Style:  
EP = Plug Terminal

POWER CONNECTOR

# CP35 Series 3.00mm (.118") Dual Row Board Mount Headers

- ⊙ Mate with CP35 Connector
- ⊙ Shrouded header with PCB mounting pegs or board locks
- ⊙ Available straight and right angle solder tails

RoHS Compliant

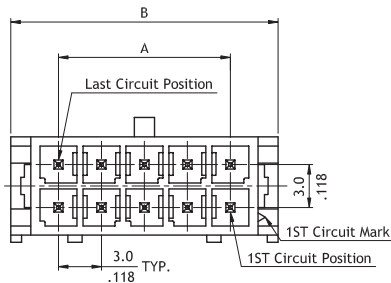
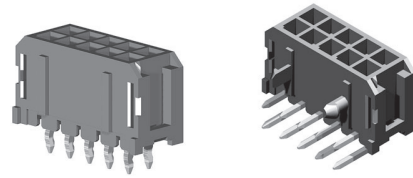

Circuits	Dimension	
	A	B
2	—	6.7(.264)
4	3.0(.118)	9.7(.382)
6	6.0(.236)	12.7(.500)
8	9.0(.354)	15.7(.618)
10	12.0(.472)	18.7(.657)
12	15.0(.591)	21.7(.854)
14	18.0(.709)	24.7(.972)
16	21.0(.827)	27.7(1.091)
18	24.0(.945)	30.7(1.209)
20	27.0(1.063)	33.7(1.327)
22	30.0(1.181)	36.7(1.445)
24	33.0(1.299)	39.7(1.563)

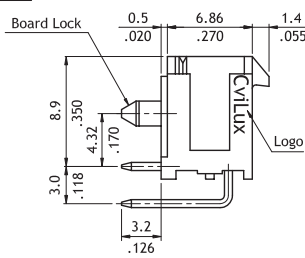
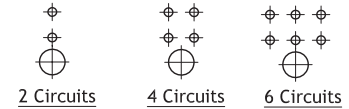
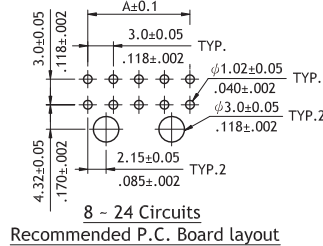
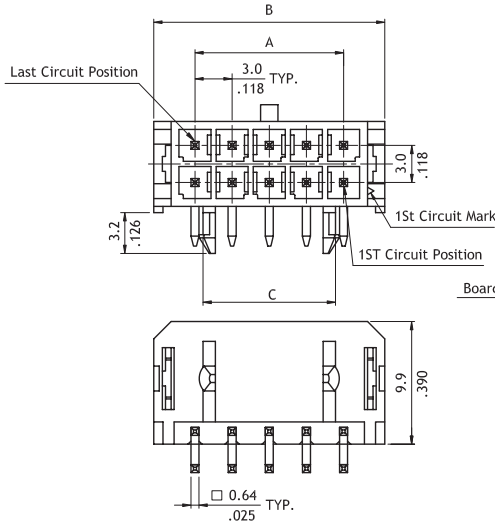
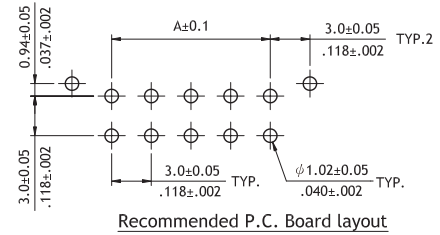
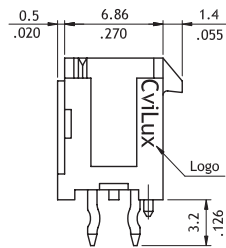
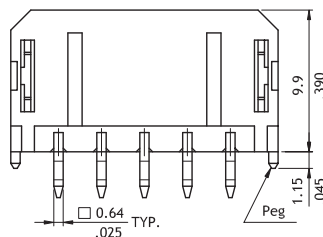

Circuits	Dimension		
	A	B	C
2	—	6.7(.264)	3.0(.118)
4	3.0(.118)	9.7(.382)	3.0(.118)
6	6.0(.236)	12.7(.500)	3.0(.118)
8	9.0(.354)	15.7(.618)	7.7(.303)
10	12.0(.472)	18.7(.657)	10.7(.421)
12	15.0(.591)	21.7(.854)	13.7(.539)
14	18.0(.709)	24.7(.972)	16.7(.657)
16	21.0(.827)	27.7(1.091)	19.7(.776)
18	24.0(.945)	30.7(1.209)	22.7(.894)
20	27.0(1.063)	33.7(1.327)	25.7(1.012)
22	30.0(1.181)	36.7(1.445)	28.7(1.130)
24	33.0(1.299)	39.7(1.563)	31.7(1.248)

## Ordering Code

① CP ② 35 ③ 24 ④ P ⑤ 1 ⑥ V ⑦ 0 ⑧ 0 - NH

- ① Series No.
- ② No. of Circuits: 02 ~ 24
- ③ P = Plug
- ④ Plating Code :
  - 1 = Matte Tin over Nickel
  - A = Selective Gold flash over Nickel
  - B = Selective 15μ" Gold flash over Nickel
- \*Optional plating available but MOQ requested
- ⑤ Contact Type : V = Straight , H = Right Angle
- ⑥ Mount Type : 0 = DIP Type
- ⑦ Other Options:
  - 0 = With pegs (Straight)
  - 0 = With plastic board locks (Right Angle)
- ⑧ NH = For Lead Free soldering process and Halogen-Free

CP35 Series 3.00mm(.118") Dual Row Side Entry SMT Headers

- ⊙ Mate with CP35 Connector
- ⊙ Shrouded header with board locks or fixed tabs
- ⊙ High temperature plastic for SMT process

RoHS Compliant 

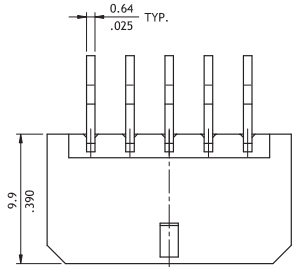
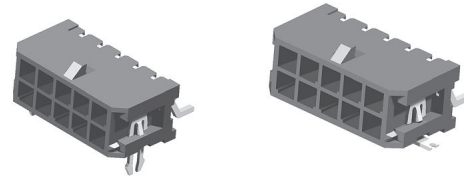

Circuits	Dimension	
	A	B
2	—	6.7(.264)
4	3.0(.118)	9.7(.382)
6	6.0(.236)	12.7(.500)
8	9.0(.354)	15.7(.618)
10	12.0(.472)	18.7(.657)
12	15.0(.591)	21.7(.854)
14	18.0(.709)	24.7(.972)
16	21.0(.827)	27.7(1.091)
18	24.0(.945)	30.7(1.209)
20	27.0(1.063)	33.7(1.327)
22	30.0(1.181)	36.7(1.445)
24	33.0(1.299)	39.7(1.563)

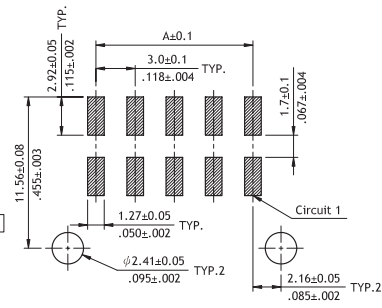
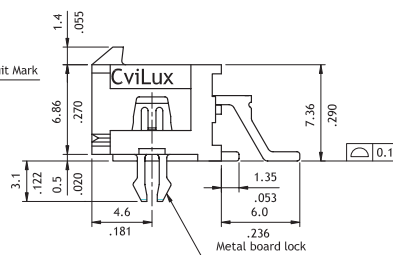
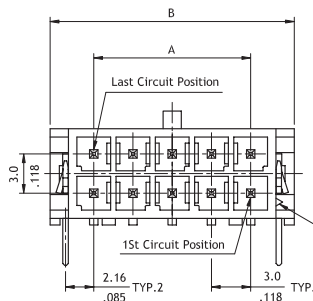

Recommended P.C. Board Layout

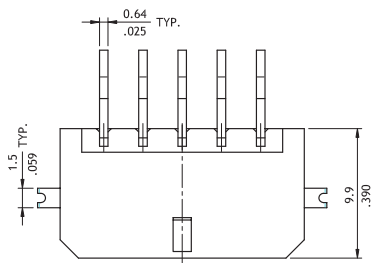

Circuits	Dimension	
	A	B
2	—	6.7(.264)
4	3.0(.118)	9.7(.382)
6	6.0(.236)	12.7(.500)
8	9.0(.354)	15.7(.618)
10	12.0(.472)	18.7(.657)
12	15.0(.591)	21.7(.854)
14	18.0(.709)	24.7(.972)
16	21.0(.827)	27.7(1.091)
18	24.0(.945)	30.7(1.209)
20	27.0(1.063)	33.7(1.327)
22	30.0(1.181)	36.7(1.445)
24	33.0(1.299)	39.7(1.563)

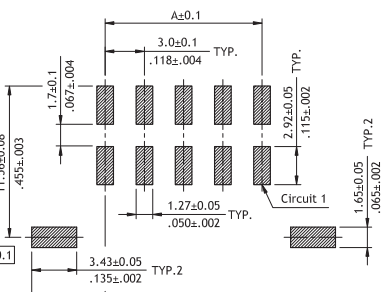
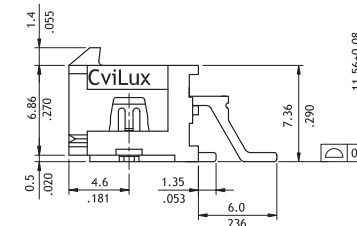
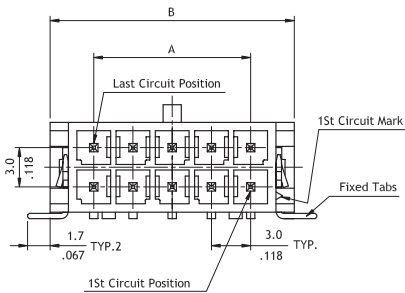

Recommended P.C. Board Layout

Ordering Code

① ② ③ ④ ⑤ ⑥ ⑦ ⑧  
**CP35 24 P 1 H S 0 - NH**

- ① Series No.
- ② No. of Circuits: 02 ~ 24
- ③ P = Plug
- ④ Plating Code : 1 = Matte Tin over Nickel  
 A = Selective Gold flash over Nickel  
 \*Optional plating available but MOQ requested
- ⑤ Contact Type: H = Side Entry
- ⑥ Mount Type: S = SMT Type
- ⑦ Other Options:  
 0 = With Metal board locks  
 T = With Fixed Tabs
- ⑧ NH = For Lead Free soldering process and Halogen-Free

## CP35 Series 3.00mm(.118") Dual Row Side Entry SMT Headers

- ⊙ Mate with CP35 Connector
- ⊙ Shrouded header with board locks
- ⊙ High temperature plastic for SMT process

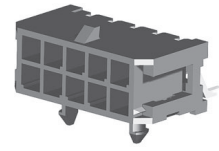

RoHS Compliant

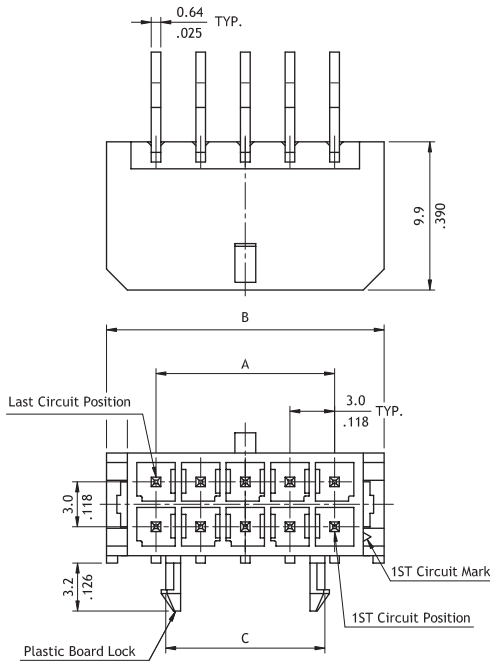

Circuits	Dimension		
	A	B	C
2	—	6.7(.264)	3.0(.118)
4	3.0(.118)	9.7(.382)	3.0(.118)
6	6.0(.236)	12.7(.500)	3.0(.118)
8	9.0(.354)	15.7(.618)	7.7(.303)
10	12.0(.472)	18.7(.736)	10.7(.421)
12	15.0(.591)	21.7(.854)	13.7(.539)
14	18.0(.709)	24.7(.972)	16.7(.657)
16	21.0(.827)	27.7(1.091)	19.7(.776)
18	24.0(.945)	30.7(1.209)	22.7(.894)
20	27.0(1.063)	33.7(1.327)	25.7(1.012)
22	30.0(1.181)	36.7(1.445)	28.7(1.130)
24	33.0(1.299)	39.7(1.563)	31.7(1.248)

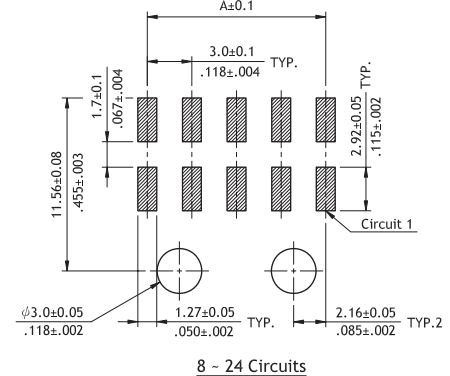
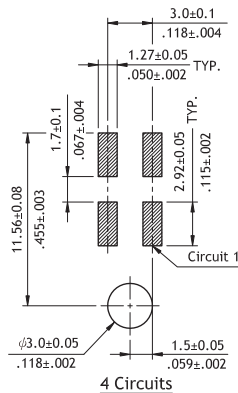
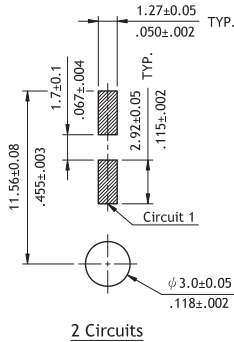
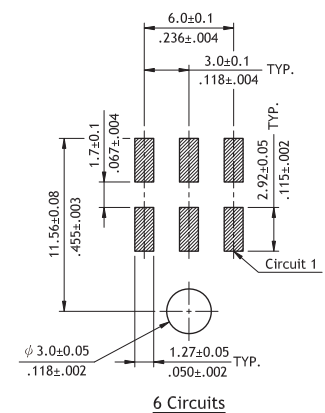
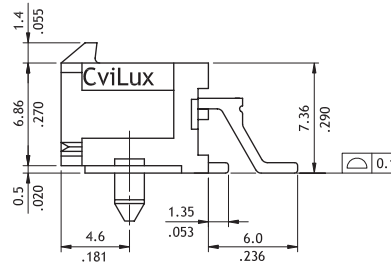

Recommended P.C. Board Layout

### Ordering Code

① ② ③ ④ ⑤ ⑥ ⑦ ⑧  
**CP35 24 P 1 H S P - NH**

- ① Series No.
- ② No. of Circuits: 02 ~ 24
- ③ P = Plug
- ④ Plating Code : 1 = Matte Tin over Nickel  
 A = Selective Gold flash over Nickel  
 \*Optional plating available but MOQ requested
- ⑤ Contact Type: H = Side Entry
- ⑥ Mount Type:  
 S = SMT Type
- ⑦ Other Options:  
 P = With plastic board lock
- ⑧ NH = For Lead Free soldering process and Halogen-Free

**CP35 Series 3.00mm(.118") Dual Row Top Entry SMT Headers**

- ⊙ Mate with CP35 Connector
- ⊙ Shrouded header with board locks or fixed tabs
- ⊙ With metal pick and place Pad
- ⊙ High temperature plastic for SMT process

RoHS Compliant 

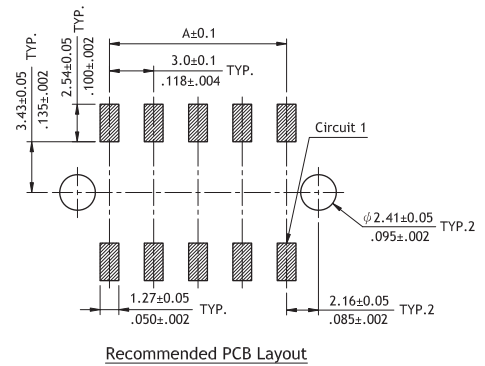
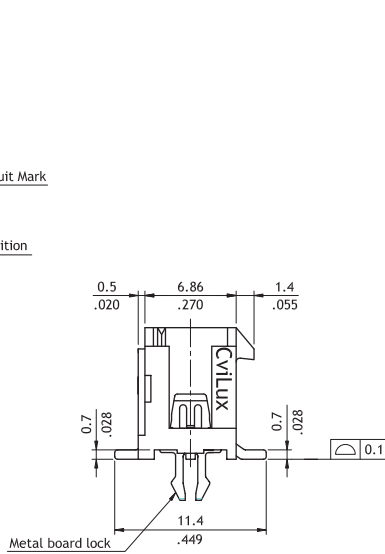
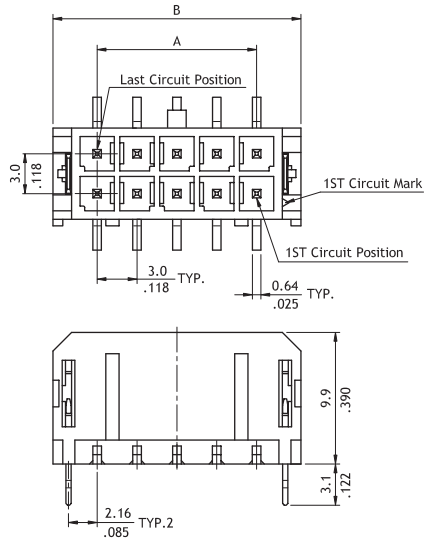
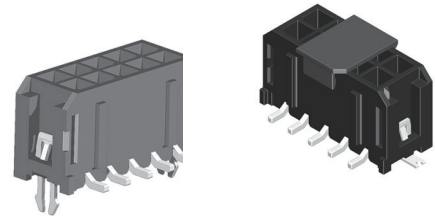

Circuits	Dimension	
	A	B
2	—	6.7(.264)
4	3.0(.118)	9.7(.382)
6	6.0(.236)	12.7(.500)
8	9.0(.354)	15.7(.618)
10	12.0(.472)	18.7(.657)
12	15.0(.591)	21.7(.854)
14	18.0(.709)	24.7(.972)
16	21.0(.827)	27.7(1.091)
18	24.0(.945)	30.7(1.209)
20	27.0(1.063)	33.7(1.327)
22	30.0(1.181)	36.7(1.445)
24	33.0(1.299)	39.7(1.563)

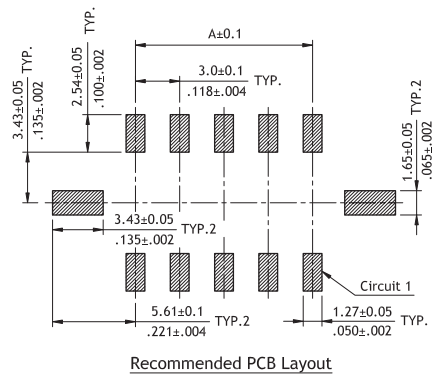
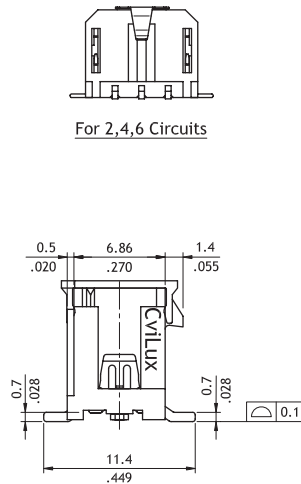
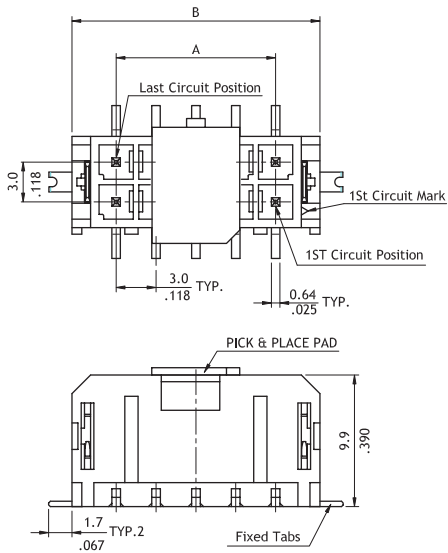

**Ordering Code**

① ② ③ ④ ⑤ ⑥ ⑦ ⑧  
**CP35 24 P 1 V S 0 - NH**

- ① Series No.
- ② No. of Circuits: 02 ~24
- ③ P = Plug
- ④ Plating Code : 1 = Matte Tin over Nickel  
 A = Selective Gold flash over Nickel  
 \*Optional available but MOQ requested
- ⑤ Contact Type: V = Top Entry
- ⑥ Mount Type: S = SMT Type
- ⑦ Other Options:  
 0 = With Metal board lock  
 T = With Fixed Tabs  
 (Available for Tape & Reel packing)
- ⑧ NH = For Lead Free soldering process and Halogen-Free

**CP-01 Series 4.20mm (.165") Power Connectors**

- ⊙ Wire to Wire and Wire to Board applications
- ⊙ Straight and Right Angle Headers
- ⊙ High current

Rated Current(max.) and Applicable Wire\*600V AC (r.m.s)

Rated Current(max.)	Wire gage/Circuits	2-3	4-6	7-10	12-24
High electric conductive copper alloy ( High current crimp terminal )	AWG#16 wire gage	12A	11A	10A	9A
	AWG#18 wire gage	12A	11A	10A	9A
	AWG#20 wire gage	9A	9A	8A	8A
	AWG#22 wire gage	7A	6A	6A	6A
	AWG#28 wire gage	3.5A	2A	2A	2A
Brass & Phosphor Bronze	AWG#16 wire gage	9A	8A	7A	6A
	AWG#18 wire gage	9A	8A	7A	6A
	AWG#20 wire gage	7A	6A	5A	5A
	AWG#22 wire gage	5A	4A	4A	4A
	AWG#24 wire gage	4A	3A	3A	3A
	AWG#26 wire gage	3A	2A	2A	2A

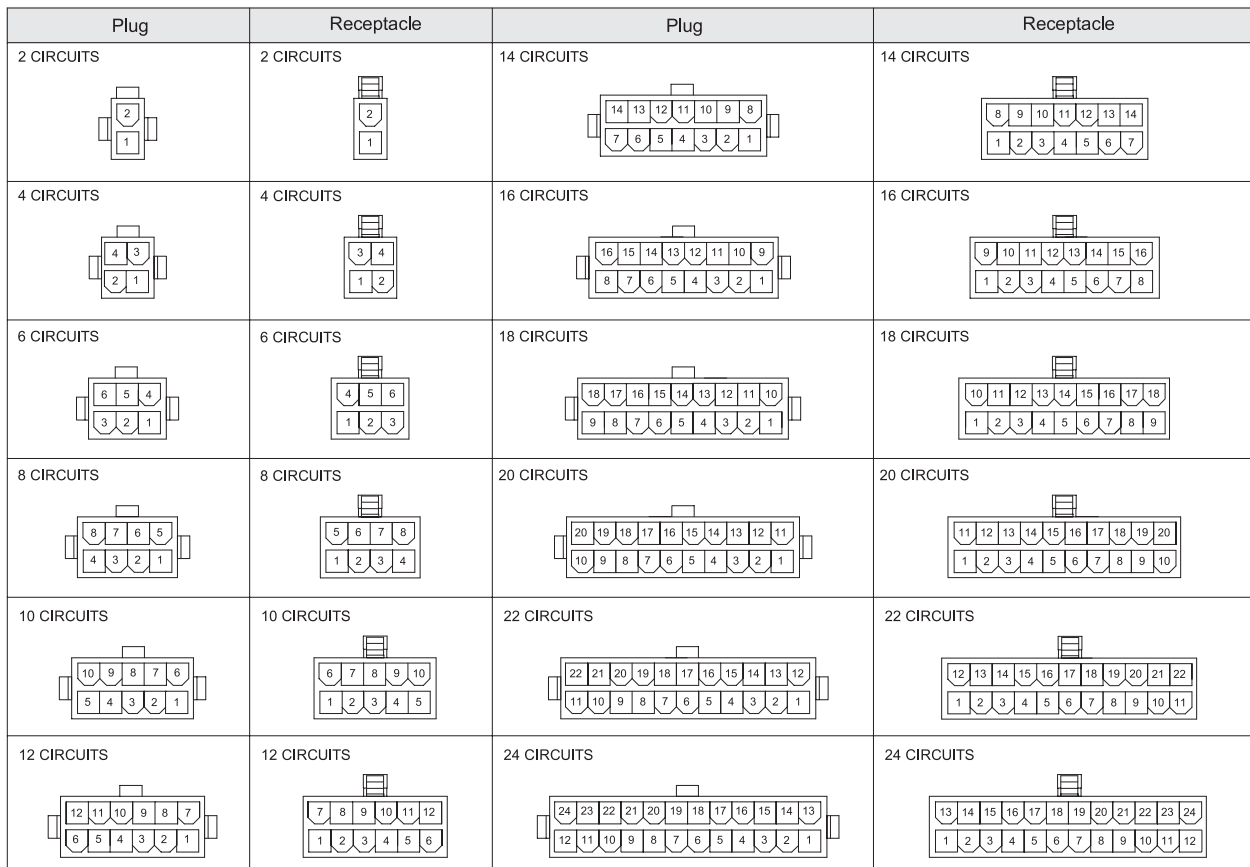

CP

POWER CONNECTOR

**CP-011 Series 4.20mm (.165") Receptacle Connectors**

- ⊙ With locking latch
- ⊙ Available in 2 through 24 circuits
- ⊙ Mates with CP-012, CP-013 or CP-014 connector
- ⊙ Nylon 66 UL 94V-0 or V-2 insulator material
- ⊙ Can be used with CP-011 crimp terminal Terminal
- ⊙ Accommodated AWG #16 ~ #26
- ⊙ Glow Wire test material available

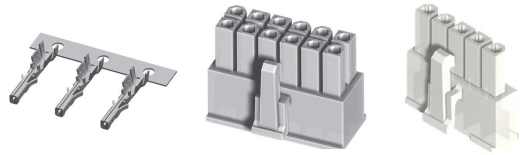

**RoHS** Compliant

P/N CP-011\*\*0\*0

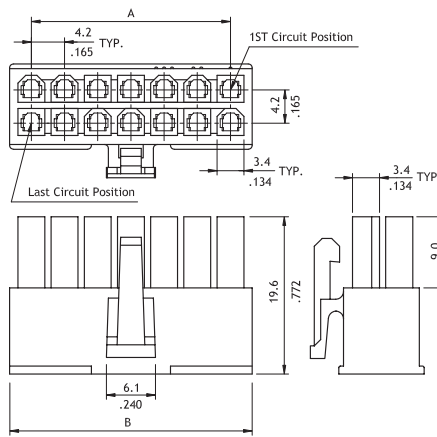

Circuits	Dimension	
	A	B
2	-	5.5(.217)
4	4.2(.165)	9.7(.382)
6	8.4(.331)	13.9(.547)
8	12.6(.496)	18.1(.713)
10	16.8(.661)	22.3(.878)
12	21.0(.827)	26.5(1.043)
14	25.2(.992)	30.7(1.209)
16	29.4(1.157)	34.9(1.374)
18	33.6(1.322)	39.1(1.539)
20	37.8(1.487)	43.3(1.705)
22	42.0(1.652)	47.5(1.870)
24	46.2(1.817)	51.7(2.035)

P/N CP-011\*\*0\*S

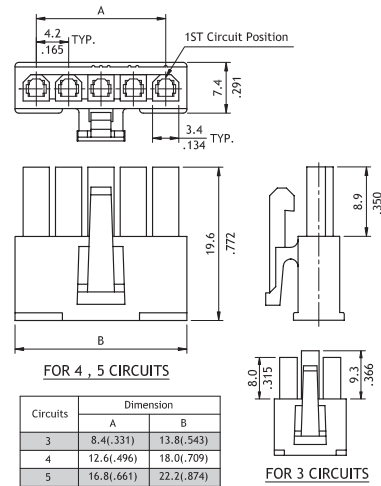

Circuits	Dimension	
	A	B
3	8.4(.331)	13.8(.543)
4	12.6(.496)	18.0(.709)
5	16.8(.661)	22.2(.874)

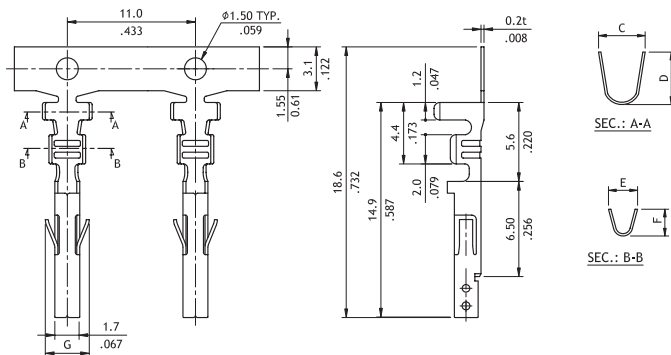

Part No.	Wire Range	Dimension					Insulation Range	Material	Reel Qty
		C	D	E	F	G			
CP-01100*01	AWG #22-26	3.4(.134)	3.3(.130)	2.5(.098)	2.3(.091)	2.6(.102)	0.9-1.8(.035-.071)	Brass	5,000 PCS
CP-01100*02	AWG #18-22	4.0(.158)	4.5(.177)	2.5(.098)	2.3(.091)	3.2(.126)	1.3-3.1(.051-.122)	Brass	4,000 PCS
CP-01100*03	AWG #22-26	3.4(.134)	3.3(.130)	2.5(.098)	2.3(.091)	2.6(.102)	0.9-1.8(.035-.071)	Phosphor Bronze	5,000 PCS
CP-01100*04	AWG #18-22	4.0(.158)	4.5(.177)	2.5(.098)	2.3(.091)	3.2(.126)	1.3-3.1(.051-.122)	Phosphor Bronze	4,000 PCS
CP-01100*05	AWG #16	4.0(.158)	4.5(.177)	2.8(.110)	2.7(.106)	3.2(.126)	1.8-3.1(.071-.122)	Brass	4,000 PCS
CP-01100*06	AWG #16	4.0(.158)	4.5(.177)	2.8(.110)	2.7(.106)	3.2(.126)	1.8-3.1(.071-.122)	Phosphor Bronze	4,000 PCS
CP-01100104-HC	AWG #18-22	4.0(.158)	4.5(.177)	2.5(.098)	2.3(.091)	3.2(.126)	1.3-3.1(.051-.122)	High electric conductive copper alloy	4,000 PCS
CP-01100106-HC	AWG #16	4.0(.158)	4.5(.177)	2.8(.110)	2.7(.106)	3.2(.126)	1.8-3.1(.071-.122)	High electric conductive copper alloy	4,000 PCS

**Ordering Code**

① ② ③ ④ ⑤ ⑥  
**CP - 01 1 24 0 1 0**

- ① Series No.
- ② Connector Type: 1 = Receptacle
- ③ No. of Circuits : 02 ~ 24 (Dual Row)  
03 ~ 05 (Single Row)
- ④ Plating Code: 0 = Non plating
- ⑤ Variation:  
1 = UL 94V-2 ; 6 = UL 94V-2, BMI Type  
3 = UL 94V-0 ; 7 = UL 94V-0, BMI Type  
E = Glow wire test approval
- ⑥ Other Options: 0 = Dual Row  
S = Single Row

\*Special options consult manufacturer

### CP-011 Series 4.20mm (.165") Blind Mating Panel Mount Receptacle Connector

- ⊙ Mates with CP-012, CP-013 or CP-014 connector
- ⊙ Nylon 66 UL 94V-0 or V-2 insulator material
- ⊙ Can be used with CP-011 crimp terminal
- ⊙ Terminal accommodated AWG #16 ~ #26

RoHS Compliant

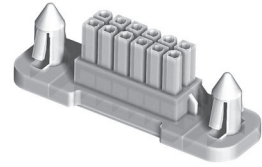

P/N CP-01104060 / CP-01104070

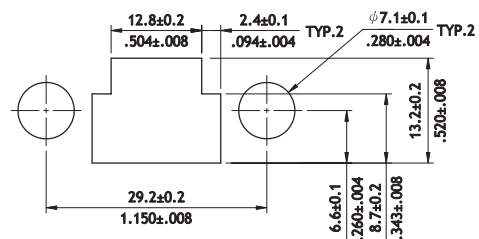
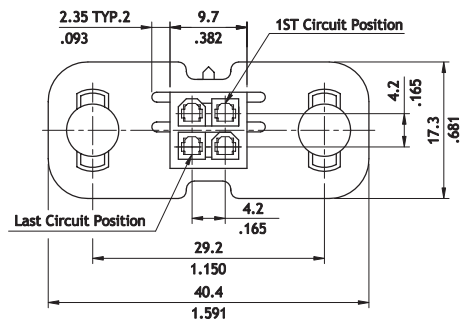

Panel Cutout (Panel Thickness= 1.6±0.05mm)

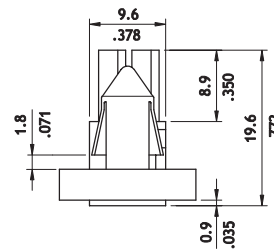
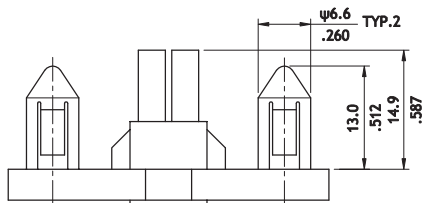

### CP-01 Series Extractor Hand Tool

- ⊙ Can be used CP-011 & CP-012 series crimp terminal

P/N CP-RWT-0201

P/N CP-RWT-0200

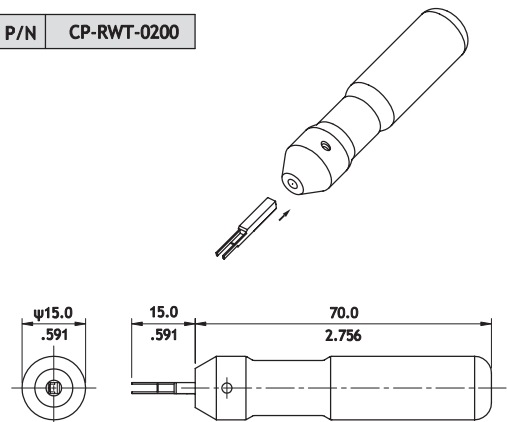
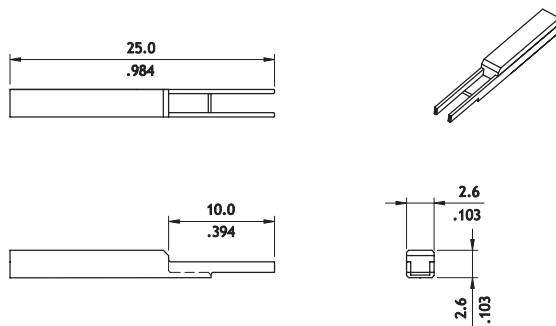

CP

POWER CONNECTOR

**CP-011 Series 4.20mm (.165") Receptacle Board Mount Connectors**

- ⊙ With Board Locks
- ⊙ Available in 2 through 24 circuits
- ⊙ Mates with CP-012, CP-013 or CP-014 connector
- ⊙ Nylon 66 UL 94V-0 or V-2 and 46 UL94V-0 insulator material
- ⊙ Glow wire test available

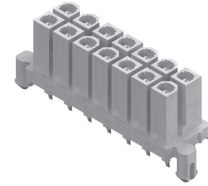

RoHS Compliant

CP

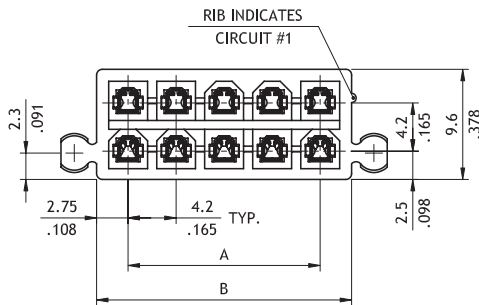

Circuits	Dimension		
	A	B	C
2	—	5.5(.217)	9.4(.370)
4	4.2(.165)	9.7(.382)	13.6(.535)
6	8.4(.331)	13.9(.547)	17.8(.701)
8	12.6(.496)	18.1(.713)	22.0(.866)
10	16.8(.661)	22.3(.878)	26.2(1.031)
12	21.0(.827)	26.5(1.043)	30.4(1.197)
14	25.2(.992)	30.7(1.209)	34.6(1.362)
16	29.4(1.157)	34.9(1.374)	38.8(1.528)
18	33.6(1.322)	39.1(1.539)	43.0(1.693)
20	37.8(1.487)	43.3(1.705)	47.2(1.858)
22	42.0(1.652)	47.5(1.870)	51.4(2.024)
24	46.2(1.817)	51.7(2.035)	55.6(2.189)

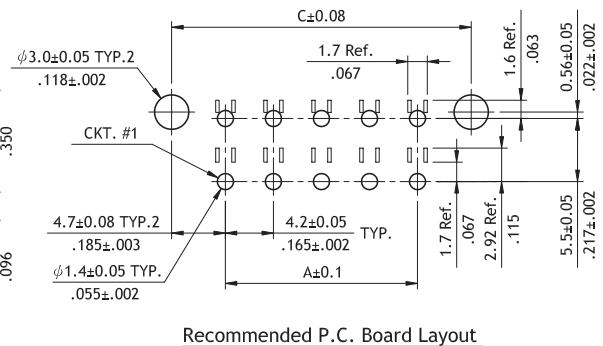
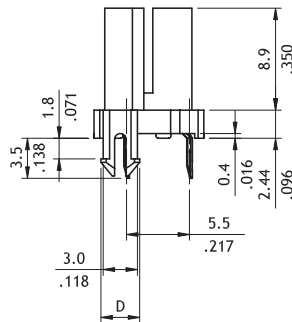
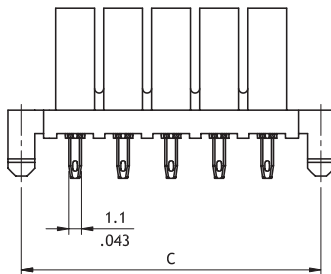

Recommended P.C. Board Layout

**Ordering Code**

① ② ③ ④ ⑤ ⑥  
**CP - 01 1 24 1 1 0**

- ① Series No.
- ② Connector Type:  
1 = Receptacle
- ③ No. of Circuits : 02 ~ 24
- ④ Plating Code : 1 = Tin over Nickel

- ⑤ Variation:  
0 = UL 94V-0 (PA46) (DIM. D = 3.2mm)  
1 = UL 94V-0 (PA66) (DIM. D = 3.4mm)  
2 = UL 94V-2 (PA66) (DIM. D = 3.4mm)  
3 = UL 94V-2 (GWT) (DIM. D = 3.4mm)
- ⑥ Other Options: 0 = Standard  
\*Special options consult manufacturer

POWER CONNECTOR

**CP-011 Series 4.20mm (.165") Assembly Power Connectors**

- ⊙ With locking latch
- ⊙ Nylon 66 UL 94V-0 insulator material
- ⊙ Can be used with CP-011 crimp terminal
- ⊙ Terminal accommodated AWG #16 ~ #26

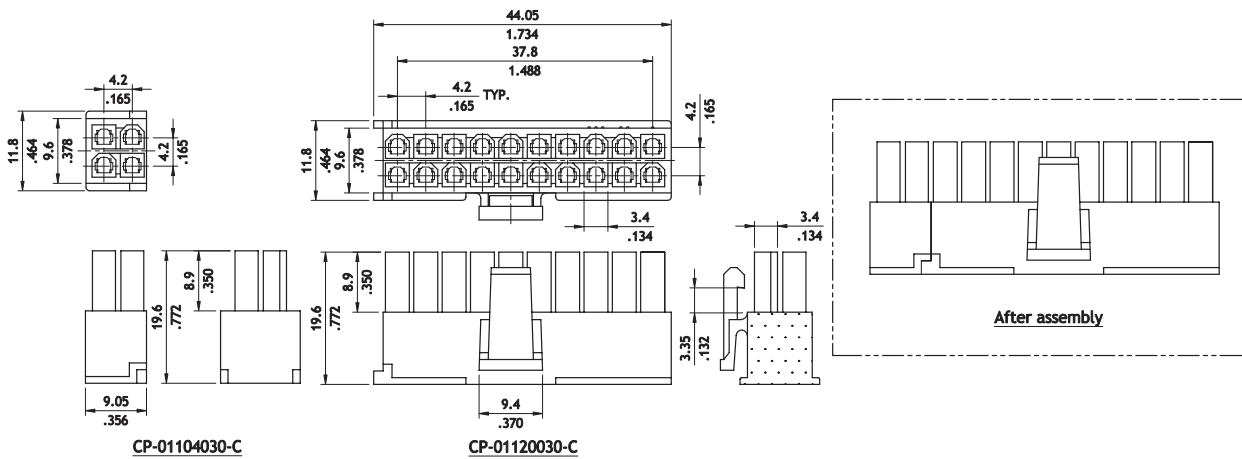
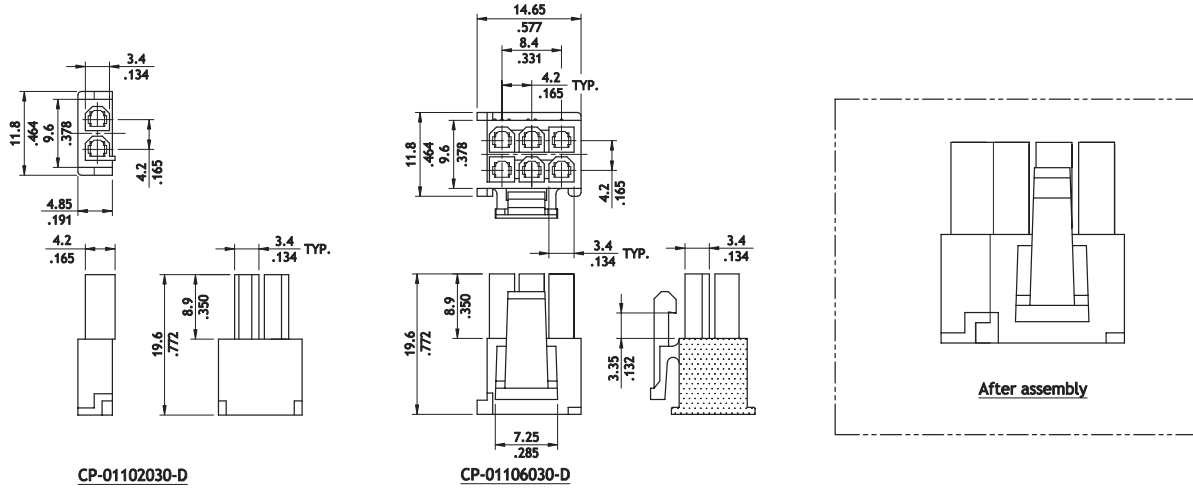
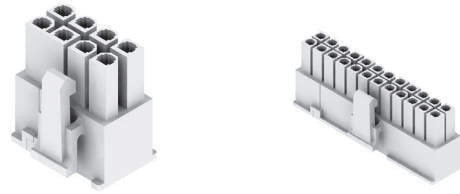

Ordering Code		①	②	③	④	⑤	⑥	⑦
		CP - 01	1	20	0	1	0	- C

① Series No.  
 ② Connector Type: 1 = Receptacle  
 ③ No. of Circuits: 02, 04, 06, 20  
 ④ Plating Code : 0 = Non plating  
 ⑤ Variation: 3 = UL 94V-0  
 ⑥ Color Options: 0 = Nature (Standard)  
 \*Special options consult manufacturer  
 ⑦ Other Options:  
 C = Assembly Type  
 D = PCI-E Assembly Type

**CP-012 Series 4.20mm (.165") Plug Connectors**

- ⊙ With mounting ears
- ⊙ Available in 2 through 24 circuits
- ⊙ Mate with CP-011 connector
- ⊙ Nylon 66 UL 94V-0 or V-2 insulator material
- ⊙ Can be used with CP-012 crimp terminal
- ⊙ Terminal accommodated AWG #16 ~ #26
- ⊙ Glow Wire test material available

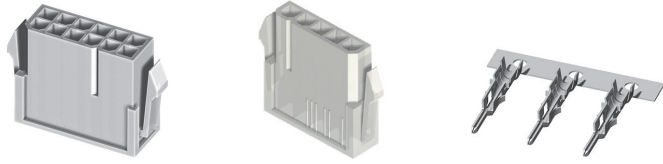

RoHS Compliant

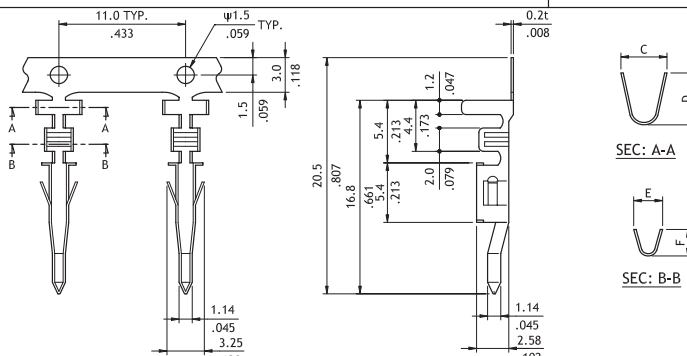
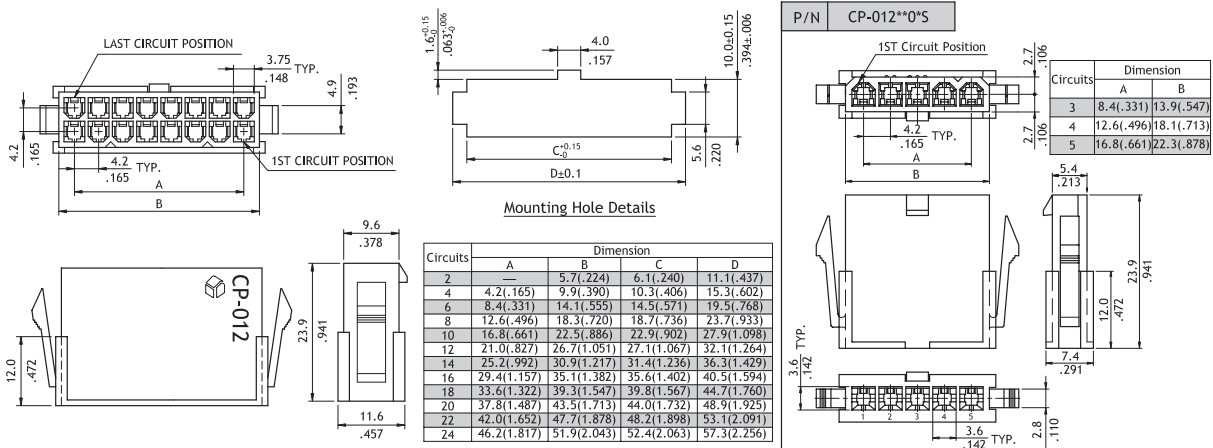

Part No.	Wire Range	Dimension				Insulation Range	Material	Reel Qty
		C	D	E	F			
CP-01200*01	AWG #22-26	3.4(.134)	3.3(.130)	2.5(.098)	2.3(.091)	0.9-1.8(.035-.071)	Brass	5,000 PCS
CP-01200*02	AWG #18-22	4.0(.158)	4.5(.177)	2.5(.098)	2.3(.091)	1.3-3.1(.051-.122)	Brass	4,000 PCS
CP-01200*03	AWG #22-26	3.4(.134)	3.3(.130)	2.5(.098)	2.3(.091)	0.9-1.8(.035-.071)	Phosphor Bronze	5,000 PCS
CP-01200*04	AWG #18-22	4.0(.158)	4.5(.177)	2.5(.098)	2.3(.091)	1.3-3.1(.051-.122)	Phosphor Bronze	4,000 PCS
CP-01200*05	AWG #16	4.0(.158)	4.5(.177)	2.8(.110)	2.6(.102)	1.8-3.1(.071-.122)	Brass	4,000 PCS
CP-01200*06	AWG #16	4.0(.158)	4.5(.177)	2.8(.110)	2.6(.102)	1.8-3.1(.071-.122)	Phosphor Bronze	4,000 PCS
CP-01200*04-HC	AWG #18-22	4.0(.158)	4.5(.177)	2.5(.098)	2.3(.091)	1.3-3.1(.051-.122)	High electric conductive copper alloy	4,000 PCS
CP-01200*06-HC	AWG #16	4.0(.158)	4.5(.177)	2.8(.110)	2.6(.102)	1.8-3.1(.071-.122)	High electric conductive copper alloy	4,000 PCS
CP-01200*07-HC	AWG #28	2.3(.091)	2.3(.091)	1.8(.071)	1.65(.065)	0.9(.035)	High electric conductive copper alloy	6,000 PCS

**Ordering Code**

① ② ③ ④ ⑤ ⑥  
**CP - 01 2 24 0 0 0**

- ① Series No.
- ② Connector Type : 2 = Plug
- ③ No. of Circuits:  
 02 ~ 24 (Dual Row)  
 03 ~ 05 (Single Row)
- ④ Plating Code: 0 = Non plating
- ⑤ Variation:  
 0 = UL 94V-2 (with mounting ears)  
 1 = UL 94V-2 (without mounting ear)  
 2 = UL 94V-0 (with mounting ears)  
 3 = UL 94V-0 (without mounting ear)  
 E = GWT approval (without mounting ear)  
 F = GWT approval (with mounting ears)
- ⑥ Other Options:  
 0 = Dual Row  
 S = Single Row  
 \*Special options consult manufacturer

CP

POWER CONNECTOR

## CP-013 Series 4.20mm (.165") Straight DIP Solder Headers

- ⊙ Optional PCB mounting pegs
- ⊙ Mate with CP-011 connector
- ⊙ Nylon 66 UL 94V-0 or V-2 insulator material
- ⊙ Glow wire test material available

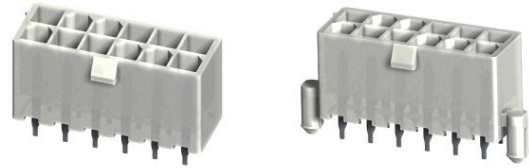

RoHS Compliant

P/N CP-013\*\*110 / CP-013\*\*130 / CP-013\*\*1E0

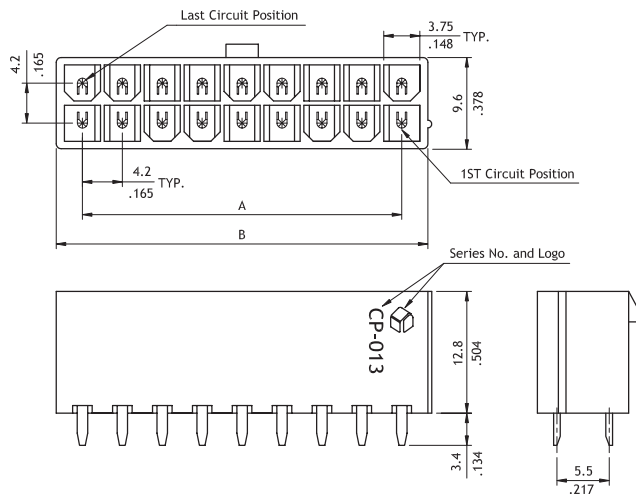

Circuits	Dimension	
	A	B
2	—	5.5(.217)
4	4.2(.165)	9.7(.382)
6	8.4(.331)	13.9(.547)
8	12.6(.496)	18.1(.713)
10	16.8(.661)	22.3(.878)
12	21.0(.827)	26.5(1.043)
14	25.2(.992)	30.7(1.209)
16	29.4(1.157)	34.9(1.374)
18	33.6(1.322)	39.1(1.539)
20	37.8(1.487)	43.3(1.705)
22	42.0(1.652)	47.5(1.870)
24	46.2(1.817)	51.7(2.035)

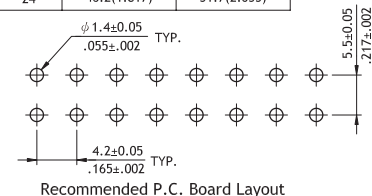

Recommended P.C. Board Layout

P/N CP-013\*\*140 / CP-013\*\*150 / CP-013\*\*1G0

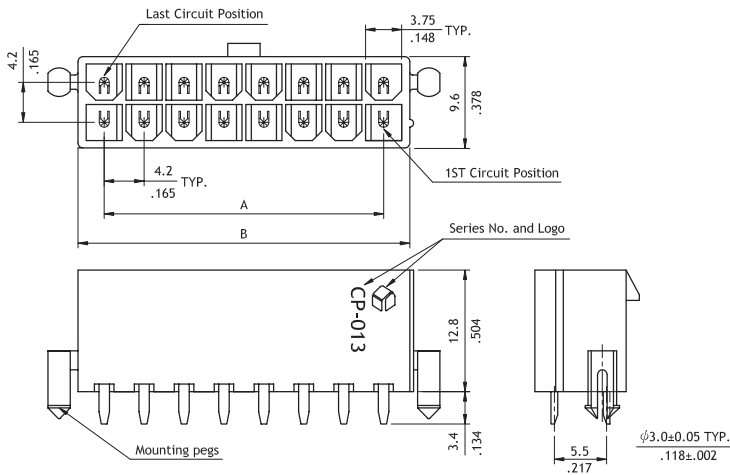

Circuits	Dimension	
	A	B
2	—	5.5(.217)
4	4.2(.165)	9.7(.382)
6	8.4(.331)	13.9(.547)
8	12.6(.496)	18.1(.713)
10	16.8(.661)	22.3(.878)
12	21.0(.827)	26.5(1.043)
14	25.2(.992)	30.7(1.209)
16	29.4(1.157)	34.9(1.374)
18	33.6(1.322)	39.1(1.539)
20	37.8(1.487)	43.3(1.705)
22	42.0(1.652)	47.5(1.870)
24	46.2(1.817)	51.7(2.035)

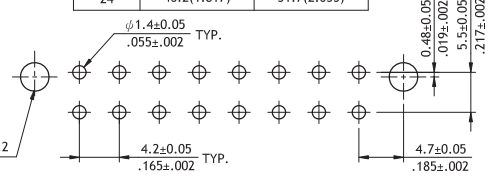

Recommended P.C. Board Layout

### Ordering Code

① ② ③ ④ ⑤ ⑥  
**CP - 01 3 24 1 1 0**

- ① Series No.
- ② Connector Type:  
3 = Straight PCB mount header
- ③ No. of Circuits : see above table
- ④ Plating Code :  
1 = Tin over Nickel

- ⑤ Variation:  
1 = UL 94V-2 (without mounting peg)  
3 = UL 94V-0 (without mounting peg)  
4 = UL 94V-2 (with mounting pegs)  
5 = UL 94V-0 (with mounting pegs)  
E = GWT approval (without mounting peg)  
G = GWT approval (with mounting pegs)

- ⑥ Other Options:  
0 = Standard (with drain holes shown, non for 2 pin Type)  
H = Without drain hole  
\*Special options consult manufacturer

**CP-013 Series 4.20mm (.165") Straight DIP Solder Headers**

- ⊙ Optional PCB mounting pegs
- ⊙ Mates with CP-011 Connector
- ⊙ Nylon 66 UL 94V-0 or V-2 insulator material
- ⊙ Glow Wire test material available

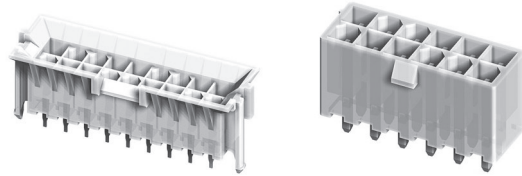

P/N CP-013\*\*160 / CP-013\*\*170 / CP-013\*\*1H0

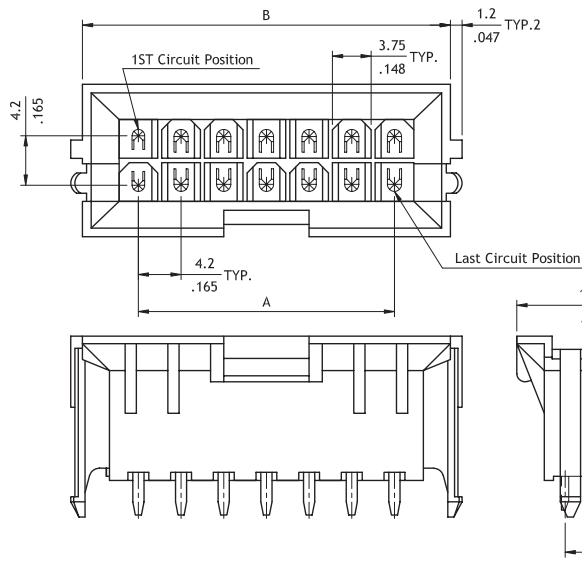

Circuits	Dimension	
	A	B
4	4.2(.165)	15.1(.594)
6	8.4(.331)	19.3(.760)
8	12.6(.496)	23.5(.925)
10	16.8(.661)	27.7(1.091)
14	25.2(.992)	36.1(1.421)
16	29.4(1.157)	40.3(1.587)
18	33.6(1.323)	44.5(1.752)
24	46.2(1.819)	57.1(2.248)

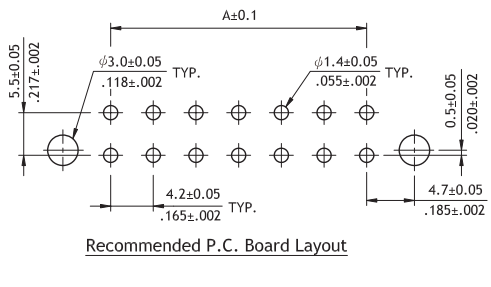

P/N CP-013\*\*180 / CP-013\*\*190 / CP-013\*\*1J0

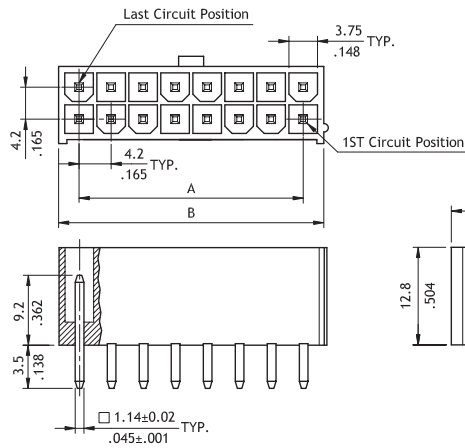

Circuits	Dimension	
	A	B
2	—	6.0(.236)
4	4.2(.165)	10.2(.402)
6	8.4(.331)	14.4(.567)
8	12.6(.496)	18.6(.732)
10	16.8(.661)	22.8(.898)
12	21.0(.827)	27.0(1.063)
14	25.2(.992)	31.2(1.228)
16	29.4(1.157)	35.4(1.394)
18	33.6(1.322)	39.6(1.559)
20	37.8(1.487)	43.8(1.724)
22	42.0(1.652)	48.0(1.890)
24	46.2(1.817)	52.2(2.055)

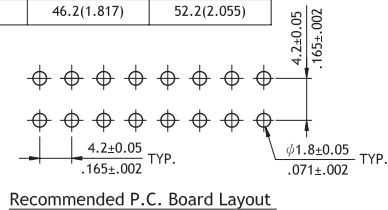

**Ordering Code**

① ② ③ ④ ⑤ ⑥  
**CP - 01 3 24 1 6 0**

- ① Series No.
- ② Connector Type:  
3 = Straight PCB mount header
- ③ No. of Circuits : see above table
- ④ Plating Code : 1 = Tin over Nickel

- ⑤ Variation : 6 = UL 94V-2 (B.M.I Type)  
7 = UL 94V-0 (B.M.I Type)  
8 = UL 94V-2 (with square pin)  
9 = UL 94V-0 (with square pin)  
J = GWT approval (with square pin)  
H = GWT approval (B.M.I Type)
- ⑥ Other Options: 0 = Standard

\*Special options consult manufacturer

## CP-013 Series 4.20mm (.165") Straight DIP Solder Headers

- ⊙ Optional PCB mounting pegs
- ⊙ Mate with CP-011 Connector
- ⊙ Nylon 66 UL 94V-0 or V-2 insulator material

RoHS Compliant

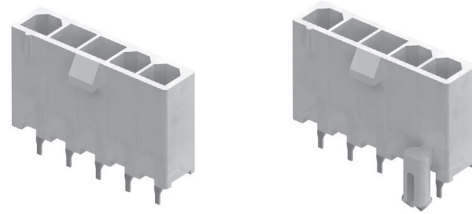

P/N CP-013\*\*11S / CP-013\*\*13S / CP-013\*\*16S / CP-013\*\*17S

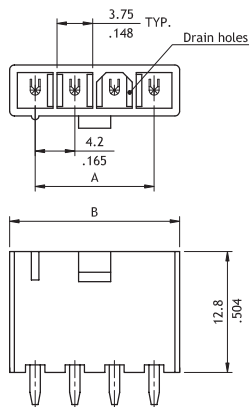

Circuits	Dimension	
	A	B
3	8.4(.331)	13.8(.543)
4	12.6(.496)	18.0(.709)
5	16.8(.661)	22.2(.874)

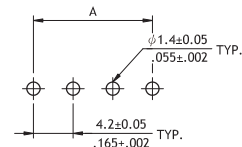
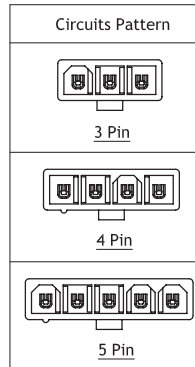

Recommended P.C. Board Layout

P/N CP-013\*\*14S / CP-013\*\*15S / CP-013\*\*18S / CP-013\*\*19S

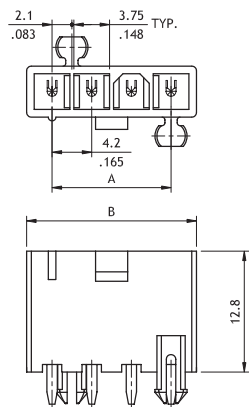

Circuits	Dimension	
	A	B
3	8.4(.331)	13.8(.543)
4	12.6(.496)	18.0(.709)
5	16.8(.661)	22.2(.874)

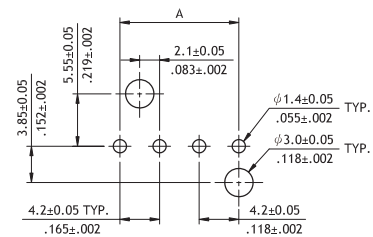
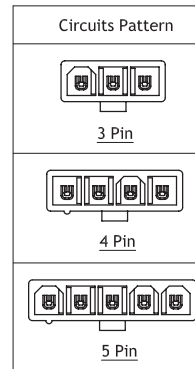

Recommended P.C. Board Layout

### Ordering Code

① ② ③ ④ ⑤ ⑥  
**CP - 01 3 05 1 S S**

- ① Series No.
- ② Connector Type:  
3 = Straight PCB mount header
- ③ No. of Circuits: see above table
- ④ Plating Code: 1 = Tin over Nickel

- ⑤ Variation:  
Without mounting peg:  
1 = UL 94V-2 (with drain holes)  
3 = UL 94V-0 (with drain holes)  
6 = UL 94V-2 (without drain hole)  
7 = UL 94V-0 (without drain hole)  
With mounting pegs:  
4 = UL 94V-2 (with drain holes)  
5 = UL 94V-0 (with drain holes)  
8 = UL 94V-2 (without drain hole)  
9 = UL 94V-0 (without drain hole)

- ⑥ Other Options:  
S = Single Row Header  
\*Special options consult manufacturer

**CP-014 Series 4.20mm (.165") Right Angle DIP Solder Headers**

- ⊙ Option with mounting ears
- ⊙ Mate with CP-011 connector
- ⊙ Nylon 66 UL 94V-0 or V-2 insulator material

RoHS Compliant 

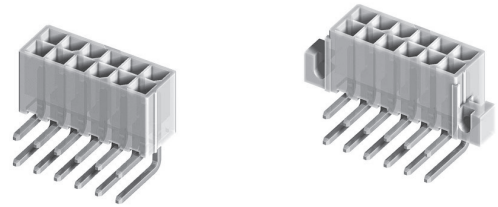

P/N CP-014\*\*110 / CP-014\*\*130

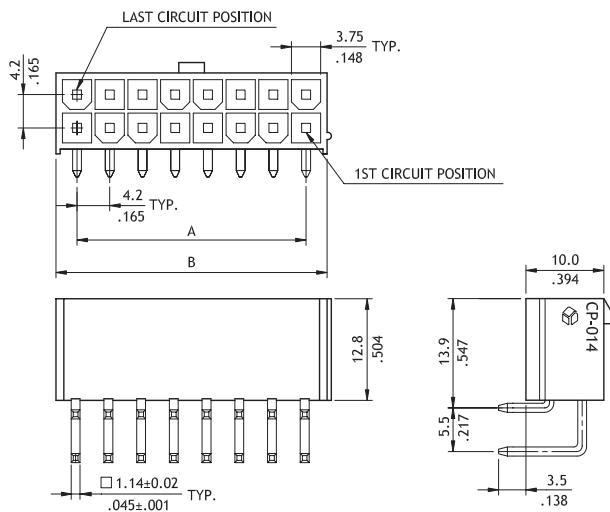

Circuits	Dimension	
	A	B
2	—	6.0(.236)
4	4.2(.165)	10.2(.402)
6	8.4(.331)	14.4(.567)
8	12.6(.496)	18.6(.732)
10	16.8(.661)	22.8(.898)
12	21.0(.827)	27.0(1.063)
14	25.2(.992)	31.2(1.228)
16	29.4(1.157)	35.4(1.394)
18	33.6(1.322)	39.6(1.559)
20	37.8(1.487)	43.8(1.724)
22	42.0(1.652)	48.0(1.890)
24	46.2(1.817)	52.2(2.055)

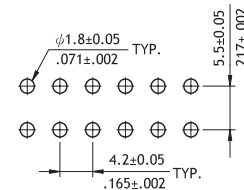

Recommended P.C. Board Layout

P/N CP-014\*\*100 / CP-014\*\*120

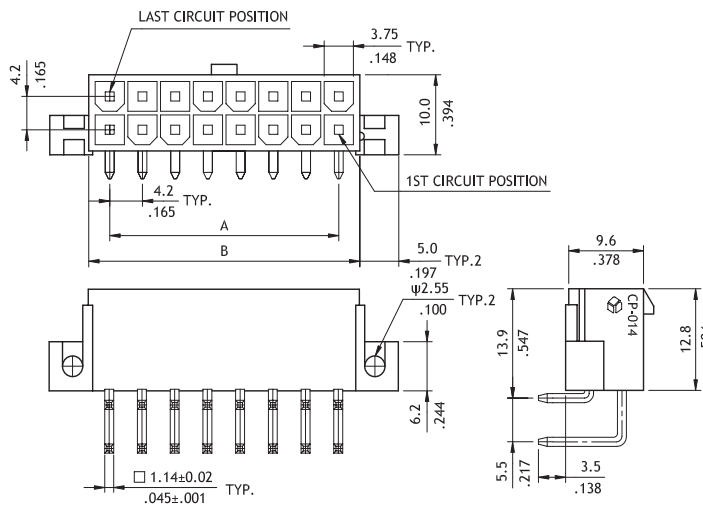

Circuits	Dimension	
	A	B
2	—	6.0(.236)
4	4.2(.165)	10.2(.402)
6	8.4(.331)	14.4(.567)
8	12.6(.496)	18.6(.732)
10	16.8(.661)	22.8(.898)
12	21.0(.827)	27.0(1.063)
14	25.2(.992)	31.2(1.228)
16	29.4(1.157)	35.4(1.394)
18	33.6(1.322)	39.6(1.559)
20	37.8(1.487)	43.8(1.724)
22	42.0(1.652)	48.0(1.890)
24	46.2(1.817)	52.2(2.055)

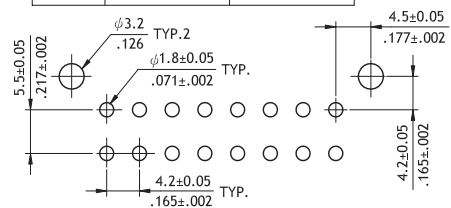

Recommended P.C. Board Layout

**Ordering Code**

① ② ③ ④ ⑤ ⑥  
**CP - 01 4 24 1 0 0**

- ① Series No.
- ② Connector Type : 4 = Right Angle Header
- ③ No. of Circuits : see above table
- ④ Plating Code : 1 = Tin over Nickel

- ⑤ Variation:
  - 0 = UL 94V-2 (with mounting ears)
  - 1 = UL 94V-2 (without mounting ear)
  - 2 = UL 94V-0 (with mounting ears)
  - 3 = UL 94V-0 (without mounting ear)
- ⑥ Other Options: 0 = Standard  
 \*Special options consult manufacturer

## CP-014 Series 4.20mm (.165") Right Angle DIP Solder Headers

- ⊙ Optional with mounting ears or pegs
- ⊙ Mate with CP-011 connector
- ⊙ Nylon 66 UL 94V-0 or V-2 insulator material
- ⊙ Glow wire test approval material available

RoHS Compliant

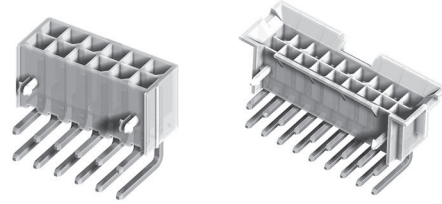

P/N CP-014\*\*140 / CP-014\*\*150 / CP-014\*\*1G0

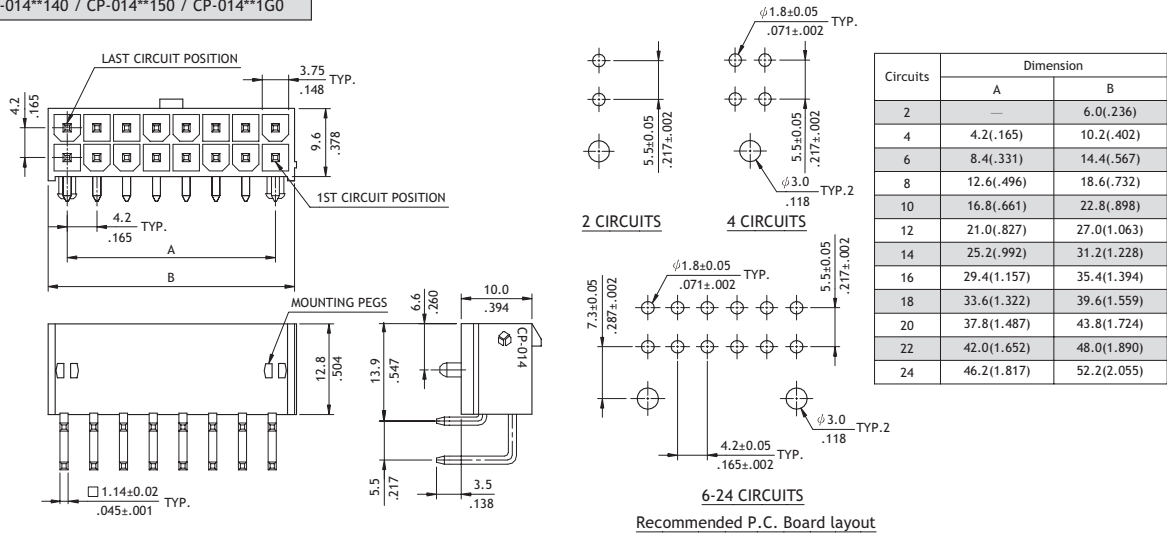

P/N CP-014\*\*160 / CP-014\*\*170 / CP-014\*\*1H0

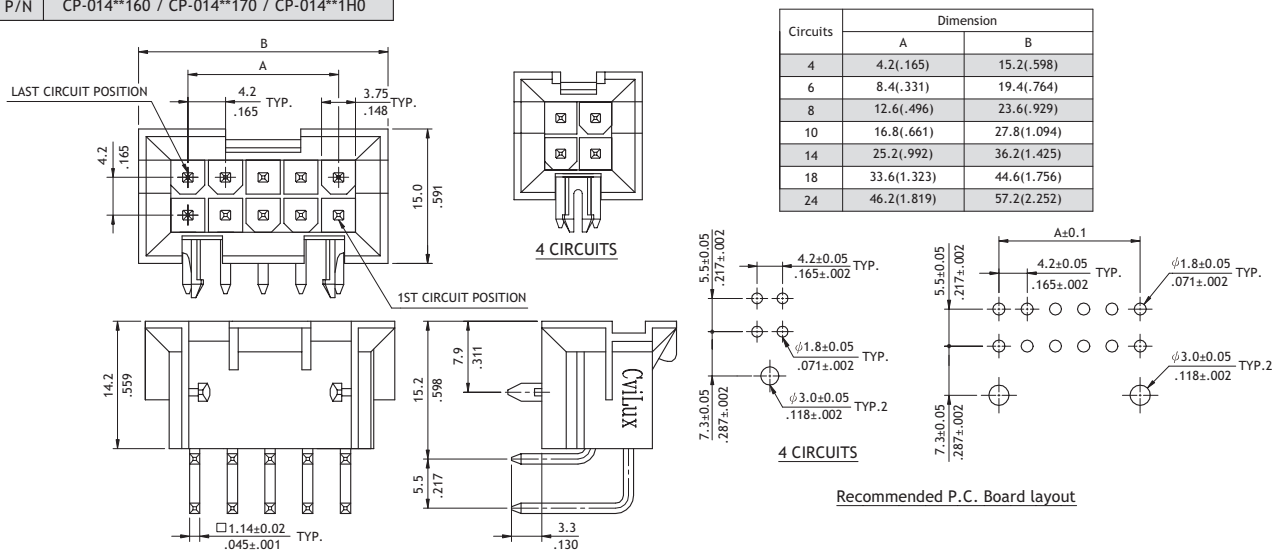

### Ordering Code

① ② ③ ④ ⑤ ⑥  
**CP - 01 4 24 1 4 0**

- ① Series No.
- ② Connector Type :  
4 = Right Angle Header
- ③ No. of Circuits : see above table
- ④ Plating Code : 1 = Tin over Nickel
- ⑤ Variation:  
4 = UL 94V-2 (with mounting pegs)  
5 = UL 94V-0 (with mounting pegs)  
6 = UL 94V-2 (B.M.I Type)  
7 = UL 94V-0 (B.M.I Type)  
G = GWT Type (with mounting pegs)  
H = GWT Type (B.M.I Type)
- ⑥ Other Options: 0 = Standard  
\*Special options consult manufacturer

**CP-014 Series 4.20mm (.165") Right Angle DIP Solder Headers**

- ⊙ Option with mounting ears or pegs
- ⊙ Mate with CP-011 connector
- ⊙ Nylon 66 UL 94V-0 or V-2 insulator material

RoHS Compliant 

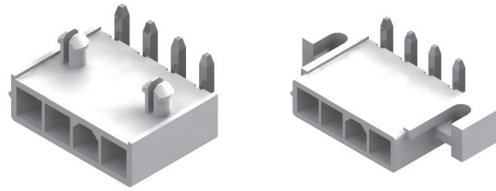

P/N CP-014\*\*10S / CP-014\*\*12S

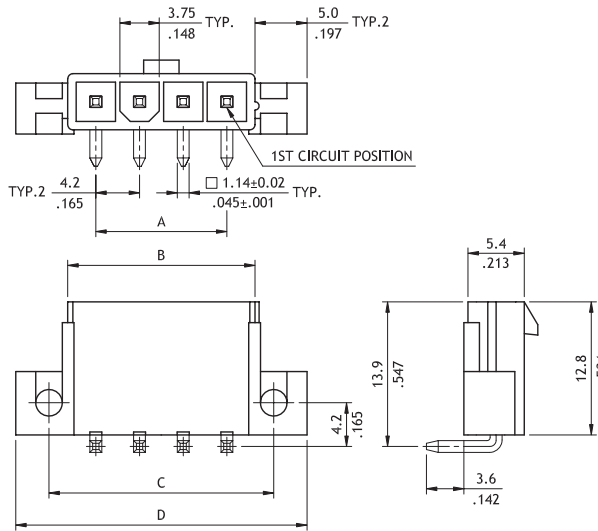

Circuits	Dimension			
	A	B	C	D
3	8.4(.331)	13.8(.543)	17.4(.685)	23.8(.937)
4	12.6(.496)	18.0(.709)	21.6(.850)	28.0(1.102)
5	16.8(.661)	22.2(.874)	25.8(1.016)	32.2(1.268)

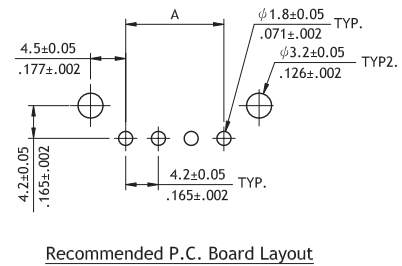
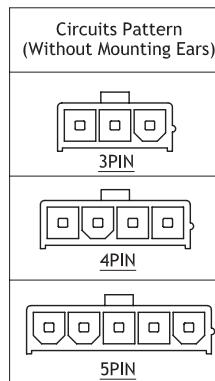

P/N CP-014\*\*11S / CP-014\*\*13S/CP-014\*\*14S / CP-014\*\*15S

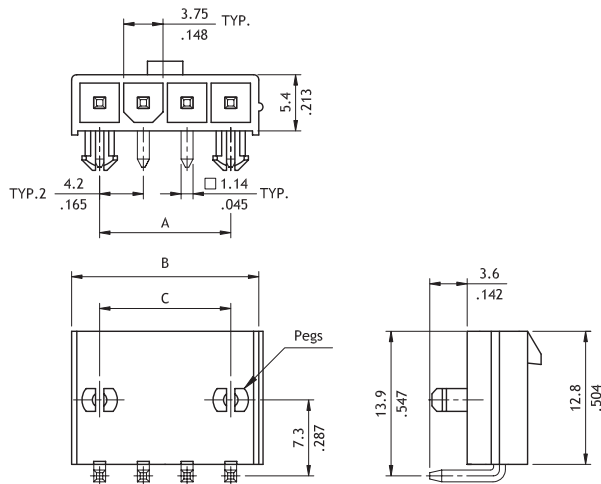

Circuits	Dimension		
	A	B	C
3	8.4(.331)	13.8(.543)	8.4(.331)
4	12.6(.496)	18.0(.709)	12.6(.496)
5	16.8(.661)	22.2(.874)	16.8(.661)

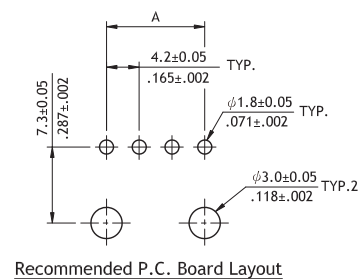
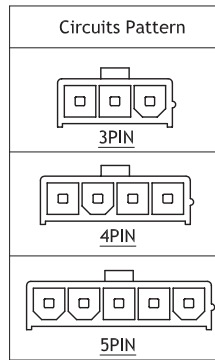

**Ordering Code**

① ② ③ ④ ⑤ ⑥  
**CP - 01 4 05 1 0 S**

- ① Series No.
- ② Connector Type:  
4 = Right Angle Header
- ③ No. of Circuits : see above table
- ④ Plating Code :  
1 = Tin over Nickel

- ⑤ Variation:  
0 = UL 94V-2 (with mounting ears)  
1 = UL 94V-2 (without mounting ear and peg)  
2 = UL 94V-0 (with mounting ears)  
3 = UL 94V-0 (without mounting ear and peg)  
4 = UL 94V-2 (with mounting pegs)  
5 = UL 94V-0 (with mounting pegs)
- ⑥ Other Options : S = Single Row Header  
\*Special options consult manufacturer

**CP32 Series 5.08mm (.200") Power Connectors**

- ⊙ Power connector for Disk Driver
- ⊙ Can be used with CP32 Crimp terminal
- ⊙ Nylon 66 UL 94V-2, Color Nature
- ⊙ Terminal: Tin plated Brass

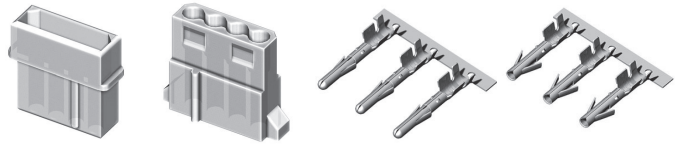

RoHS Compliant

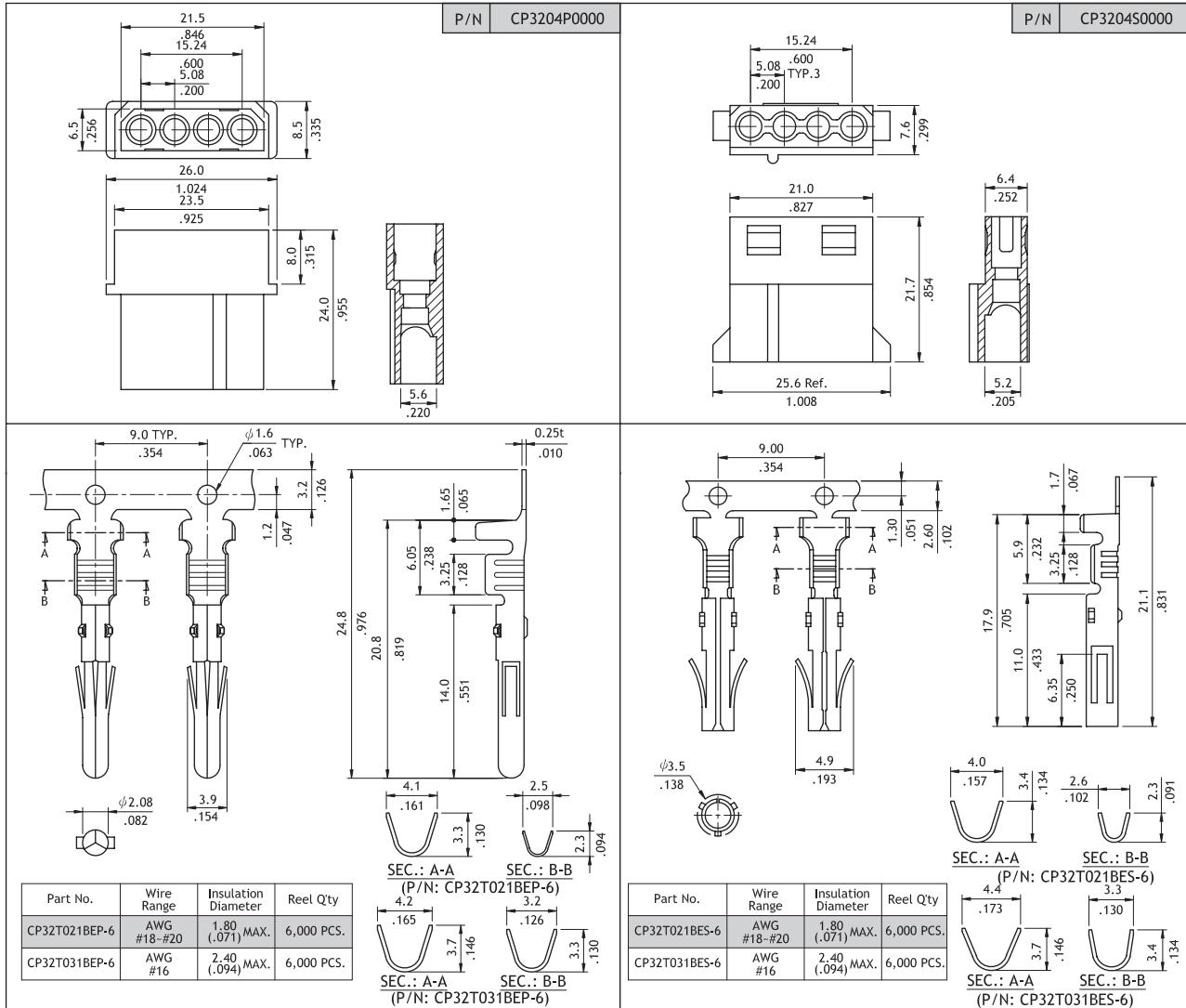

**Ordering Code**

① CP ② 32 ③ 04 ④ S ⑤ 000

- ① Series No.
- ② No. of Circuits: 04
- ③ Type: P = Plug  
S = Receptacle
- ④ Color: 0 = Nature
- ⑤ Other Options:  
000 = Standard  
\*Special options consult manufacturer

CP

POWER CONNECTOR

**CP33 Series 5.08mm (.200") IDC Receptacle Power Connectors**

- ⊙ Insulator displacement termination
- ⊙ Option closed end daisy chain cover
- ⊙ Mates with CP32 or CP33 plug connector
- ⊙ Accept AWG #18 ~#22 wire
- ⊙ Nylon 66 UL 94V-0 or V-2 Color Nature
- ⊙ Contact: Tin plated Phosphor Bronze

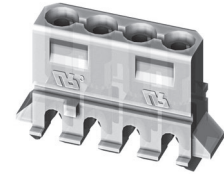

**RoHS** Compliant

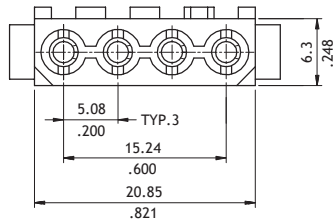

Part No.	Flame Class	Wire Range
CP3304S1000	94V-2	AWG #18-#20
CP3304S100A	94V-2	AWG #22
CP3304S100B	94V-0	AWG #18-#20
CP3304S100C	94V-0	AWG #22

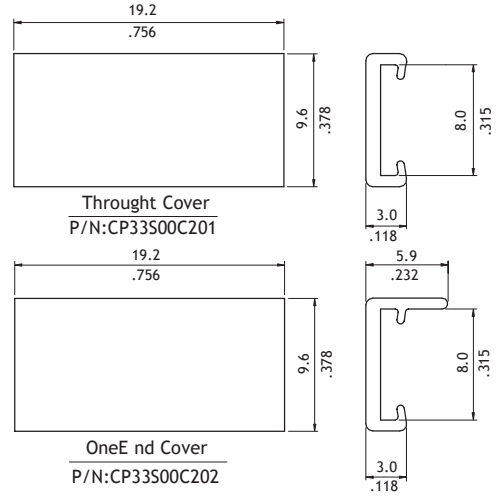
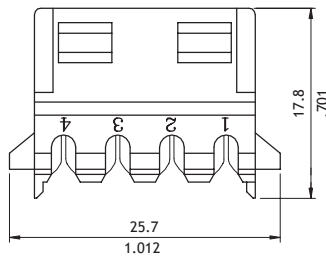

**CP33 Series 5.08mm (.200") Board Mount Plug Power Connectors**

- ⊙ Optional mounting pegs
- ⊙ Mate with CP32 or CP33 Receptacle connector
- ⊙ Nylon 66 UL V-2 Color Nature
- ⊙ Contact: Tin plated Brass

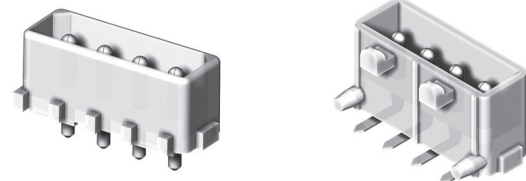

**RoHS** Compliant

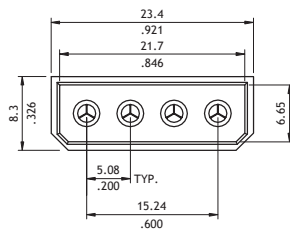

P/N CP3304P1V00

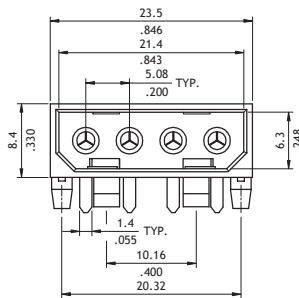

P/N CP3304P1H00

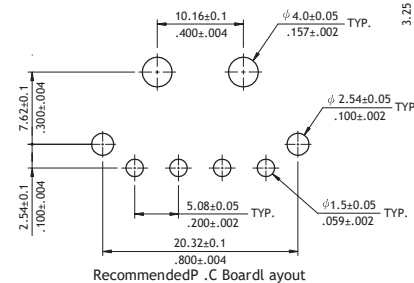
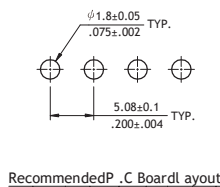
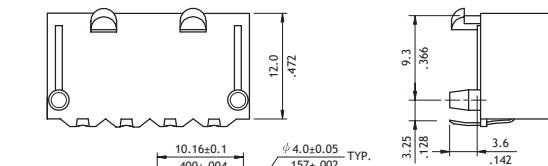
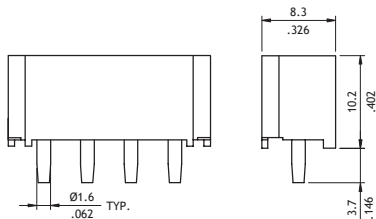

**CP60 Series 5.7mm (.224) Dual Row Receptacle Connectors**

- ⊙ Mate with CP60 Header
- ⊙ Can be used with CP60 Crimp Clip terminal
- ⊙ Insulator : UL 94V-0 , Color Black
- ⊙ Terminal accommodated AWG#12~#16
- ⊙ Maximum applied current 23A

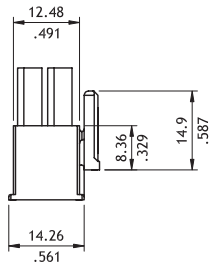
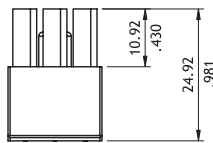
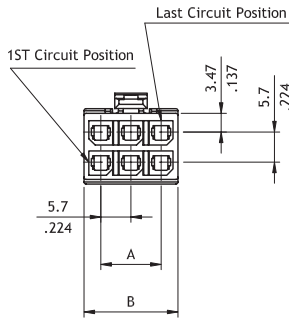
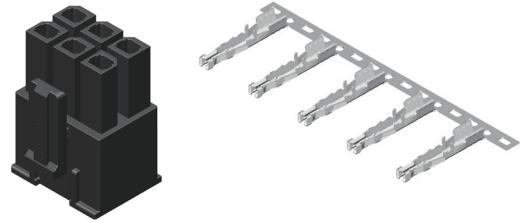

Circuits	Dimension	
	A	B
2	-	8.35(.329)
4	5.7(.224)	12.05(.474)
6	11.4(.449)	17.75(.699)
8	17.1(.673)	23.45(.923)
10	22.8(.898)	29.15(1.148)
12	28.5(1.122)	34.85(1.372)

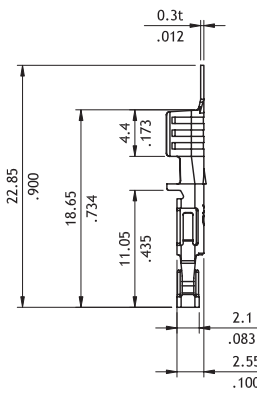
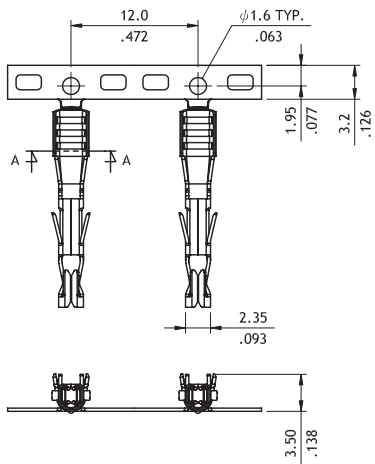

P/N	Wire Range	Reel Qty
CP60T04*PP0-HC	AWG #12	4,000 PCS
CP60T03*PP0-HC	AWG #14-#16	4,250 PCS

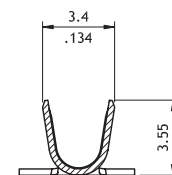

SEC. A-A  
P/N:CP60T03\*PP0-HC

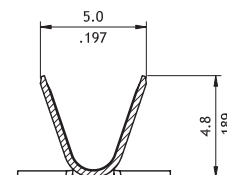

SEC. A-A  
P/N:CP60T04\*PP0-HC

**Ordering Code**

① CP 60 ② 12 ③ S ④ N01 ⑤ 0

- ① Series No.
- ② No. of Circuits: 02 ~ 12
- ③ S = Housing
- ④ Color: N01 = Black Color
- ⑤ Other options : 0= Standard

① CP 60 ② T04 ③ 1 ④ PP ⑤ 0 - ⑥ HC

- ① Series No.
- ② Wire Range: T04 = AWG #12 , T03 = AWG #14 - #16
- ③ Plating Code:
  - 1 = Tin over Nickel
  - B = Selective 15μ" Gold flash over Nickel
  - C = Selective 30μ" Gold flash over Nickel
- ④ Plating method : PP =Post plating
- ⑤ Options: 0 = Standard
- ⑥ HC= High Current Copper Alloy

**CP60 Series 5.7mm (.224) Dual Row Board Mount Header**

- ⊙ Mate with CP60 Connector
- ⊙ High temperature plastic UL 94V-0
- ⊙ With PCB mounting pegs
- ⊙ Maximum applied current 23A

RoHS Compliant 

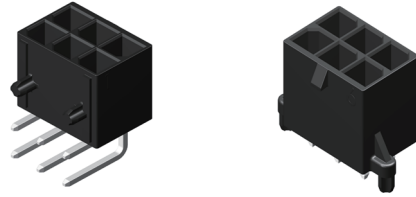

CP

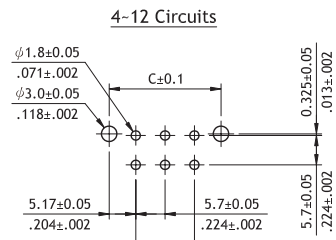
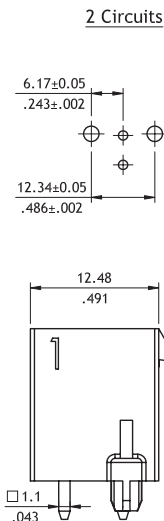
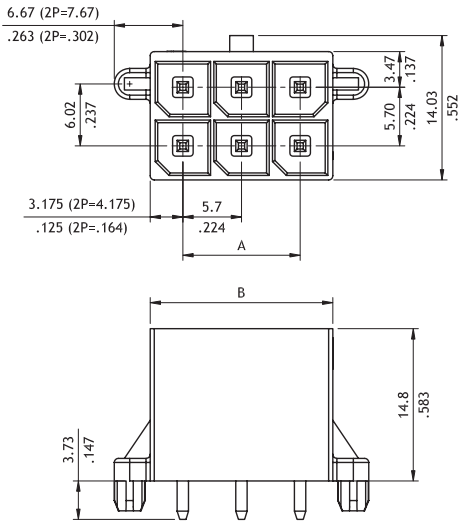

Recommended P.C. Board layout

Circuits	Dimension		
	A	B	C
2	-	8.35(.329)	12.34(.486)
4	5.7(.224)	12.05(.474)	16.04(.631)
6	11.4(.449)	17.75(.699)	21.74(.856)
8	17.1(.673)	23.45(.923)	27.44(1.080)
10	22.8(.898)	29.15(1.148)	33.14(1.305)
12	28.5(1.122)	34.85(1.372)	38.84(1.529)

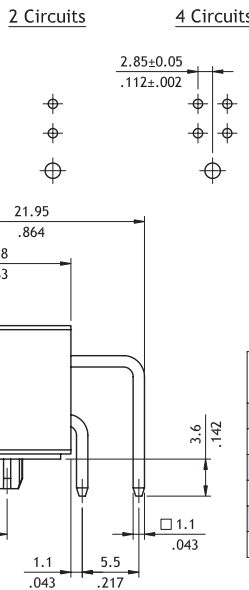
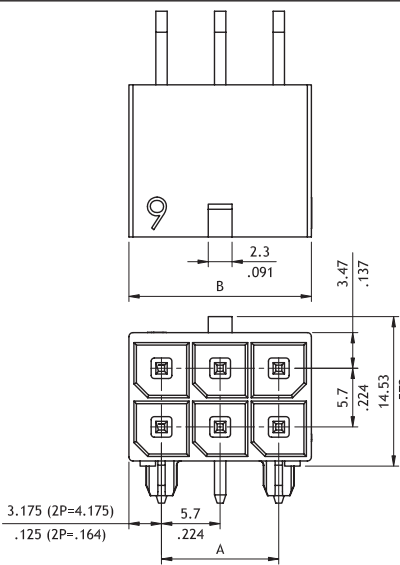

Recommended P.C. Board layout

Circuits	Dimension		
	A	B	C
2	-	8.35(.329)	-
4	5.7(.224)	12.05(.474)	-
6	11.4(.449)	17.75(.699)	11.4(.449)
8	17.1(.673)	23.45(.923)	17.1(.673)
10	22.8(.898)	29.15(1.148)	22.8(.898)
12	28.5(1.122)	34.85(1.372)	28.5(1.122)

**Ordering Code**

① ② ③ ④ ⑤ ⑥ ⑦  
**CP60 12 P 1 V 00 - NH**

- ① Series No.
- ② No. of Circuits: 02 ~ 12
- ③ P = DIP Type
- ④ Plating Code:  
 1 = Tin over Nickel  
 B= Selective 15μ" Gold flash over Nickel  
 C= Selective 30μ" Gold flash over Nickel
- ⑤ Type  
 V=Straight Type  
 H=Right Angle Type
- ⑥ Option : 00=Standard
- ⑦ NH = For Lead Free soldering process and Halogen-Free

POWER CONNECTOR

## CP08 Series 6.35mm (.250) Single Row Power Connectors

- ⊙ Can be used CP08 Crimp Clip terminal
- ⊙ Insulator Nylon 66 UL 94V-0 , Color Nature
- ⊙ Mate with CP08 Header
- ⊙ Terminal accommodated AWG#14~#20

RoHS Compliant

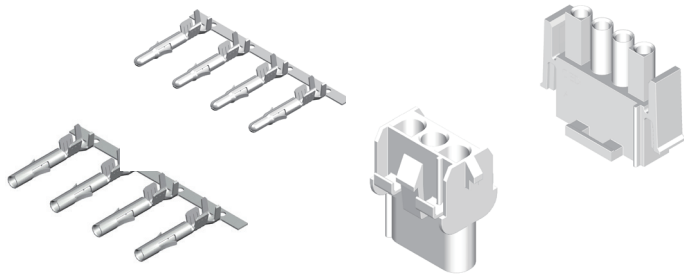

P/N CP08\*\*SCS00

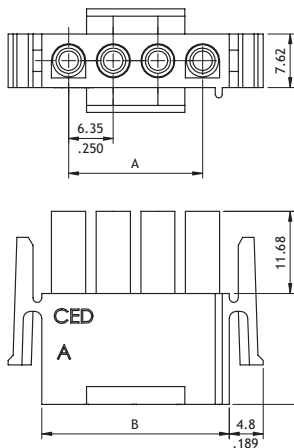

Circuits	Dimension	
	A	B
2	6.35(.250)	13.97(.550)
3	12.70(.500)	20.32(.800)
4	19.05(.750)	26.67(1.050)
5	25.40(1.000)	33.02(1.300)

P/N CP08TC3\*\*\*S

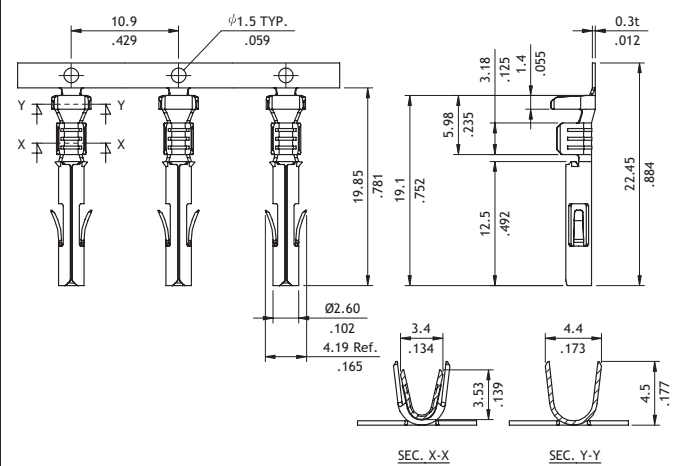

P/N CP08\*\*PCS00

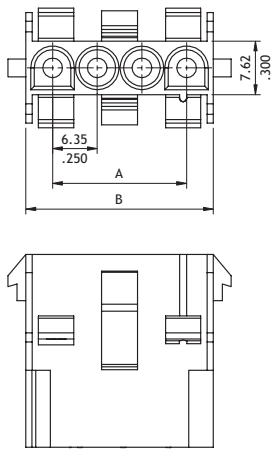

Circuits	Dimension	
	A	B
2	6.35(.250)	13.97(.550)
3	12.70(.500)	20.32(.800)
4	19.05(.750)	26.67(1.050)
5	25.40(1.000)	33.02(1.300)

P/N CP08TC3\*\*\*P

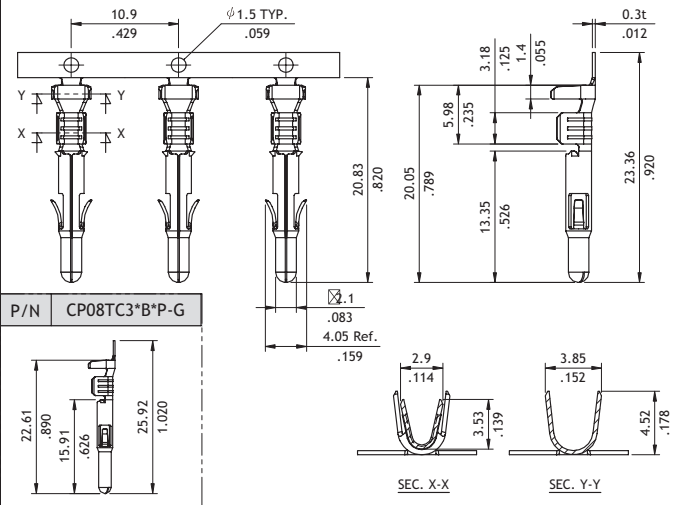

P/N CP08TC3\*B\*P-G

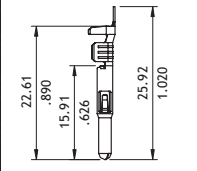

### Ordering Code

① CP08 ② 10 ③ S ④ CS ⑤ 00      ① CP08 ② TC3 ③ 1 ④ P ⑤ EP - ⑥ G

- |   |  |  |
|---|--|--|
| <ul style="list-style-type: none"> <li>① Series No.</li> <li>② No. of Circuits: 02 ~ 06 , 08 , 10</li> <li>③ S = Receptacle Housing<br/>P = Plug Housing</li> <li>④ Type: CS = Single Row</li> <li>⑤ Other Option: 00 = Standard</li> </ul> | <ul style="list-style-type: none"> <li>① Series No.</li> <li>② Wire Range: TC3 = AWG #14 ~ #20</li> <li>③ Plating Code :<br/>1 = Tin over Nickel<br/>C = Selective 30µ" Gold flash over Nickel</li> <li>④ Material:<br/>P = Phosphor Bronze<br/>B = Brass</li> </ul> | <ul style="list-style-type: none"> <li>⑤ Option:<br/>ES = Receptacle Terminal (Tin)<br/>EP = Plug Terminal (Tin)<br/>PS = Receptacle Terminal(Gold)<br/>PP = Plug Terminal (Gold)</li> <li>⑥ G = Ground Type<br/>(Only for Plug terminal)</li> </ul> |
|---|--|--|

**CP08 Series 6.35mm (.250) Single Row Power Connectors**

- ⊙ Insulator Nylon 66 UL 94V-0 , Color Nature
- ⊙ Mate with CP08 Housing
- ⊙ With PCB mounting pegs

RoHS Compliant 

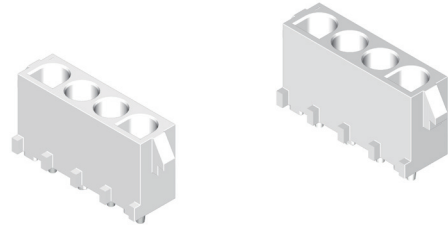

P/N CP08\*\*P1VCP

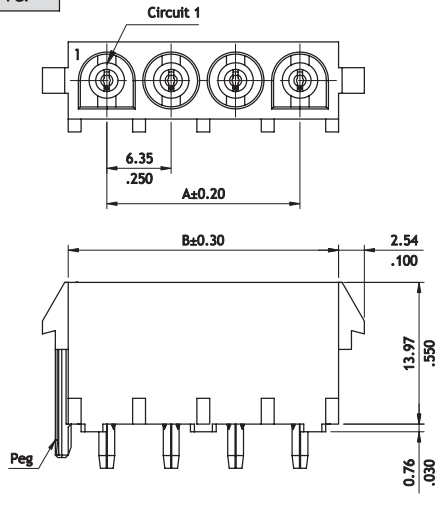

Circuits	Dimension	
	A	B
2	6.35	13.97
3	12.70	20.32
4	19.05	26.67
5	25.40	33.02

P/N CP08\*\*P1VCS

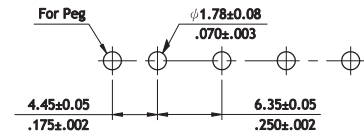
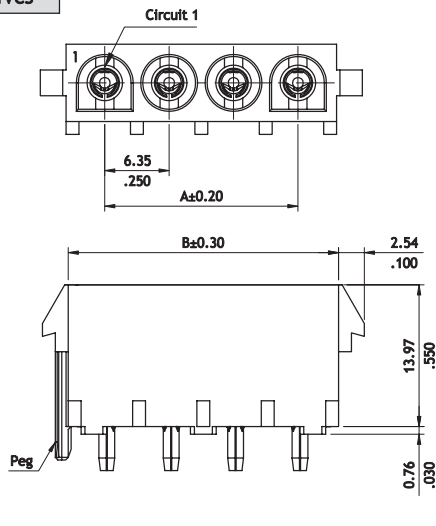

Recommended P.C. Board layout

**Ordering Code**

① ② ③ ④ ⑤ ⑥ ⑦  
**CP08 05 P 1 V C P**

- ① Series No.
- ② No. of Circuits: 02 ~ 05
- ③ Contact Type : P = Board mount type
- ④ Plating Code : 1 = Tin over Nickel

- ⑤ Type: V=Straight Type
- ⑥ Material: C = Single Row
- ⑦ Other Options:  
 P = Male contact  
 S = Female contact

**CP08 Series 6.35mm (.250) Triple Row Power Connectors**

- ⊙ Can be used CP08 Crimp Clip terminal
- ⊙ Insulator Nylon 66 UL 94V-0 , Color Nature
- ⊙ Mate with CP08 Triple Row Header
- ⊙ Terminal accommodated AWG#14~#20

RoHS Compliant

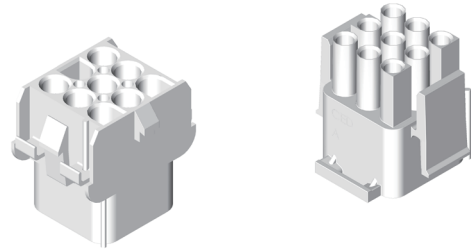

P/N	CP08**SCT00
Mate with CP08TC3***S	

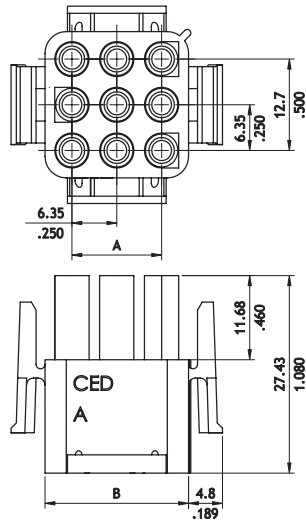

Circuits	Dimension	
	A	B
6	6.35(.250)	13.97(.550)
9	12.70(.500)	20.32(.800)
12	19.05(.750)	26.67(1.050)
15	25.40(1.000)	33.02(1.300)

P/N	CP08**PCT00
Mate with CP08TC3***P	

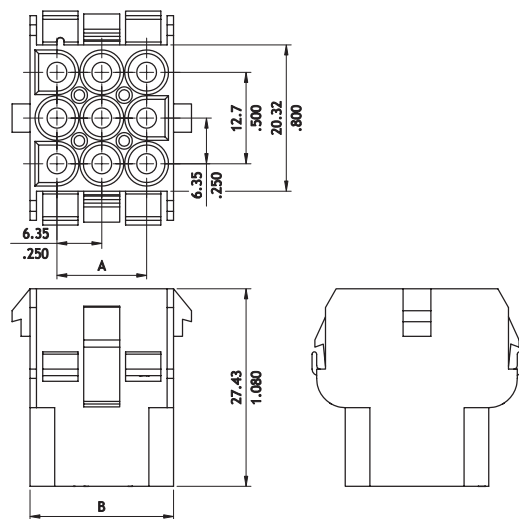

Circuits	Dimension	
	A	B
6	6.35(.250)	13.97(.550)
9	12.70(.500)	20.32(.800)
12	19.05(.750)	26.67(1.050)
15	25.40(1.000)	33.02(1.300)

**Ordering Code**

① CP 0 8    ② 1 2    ③ S    ④ CT    ⑤ 0 0

- ① Series No.
- ② No. of Circuits: 06 , 09 , 12 , 15
- ③ S = Receptacle Housing
- ④ Type : CT = Triple Row
- ⑤ Other options : 00= Standard

① CP 0 8    ② 1 0    ③ P    ④ CT    ⑤ 0 0

- ① Series No.
- ② No. of Circuits: 06 , 09 , 12 , 15
- ③ P = Plug Housing
- ④ Type : CT = Triple Row
- ⑤ Other options : 00= Standard

**CP08 Series 6.35mm (.250) Triple Row Power Connectors**

- ⊙ Insulator Nylon 66 UL 94V-0 , Color Nature
- ⊙ Mate with CP08 Triple Row Header
- ⊙ Option PCB mounting ped

**RoHS** Compliant

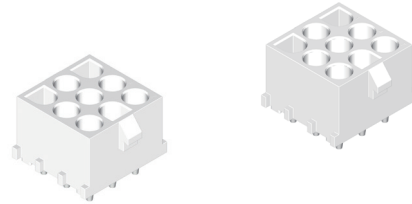

P/N CP08\*\*P1VDP

P/N CP08\*\*P1VDP-N (without peg)

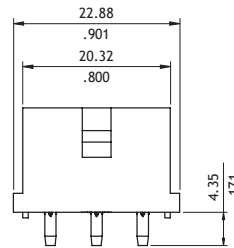
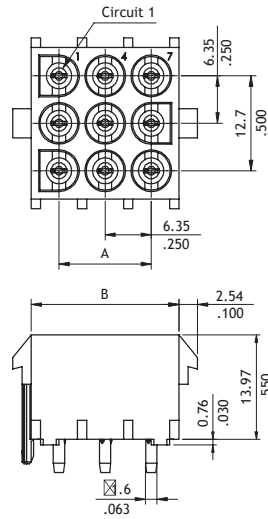
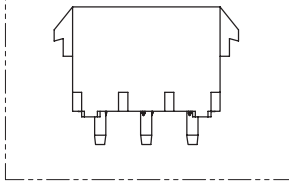

Circuits	Dimensions	
	A	B
06	6.35(.250)	13.97(.550)
09	12.70(.500)	20.32(.800)
12	19.05(.750)	26.67(1.050)
15	25.40(1.000)	33.02(1.300)

P/N CP08\*\*P1VDS

P/N CP08\*\*P1VDS-N (without peg)

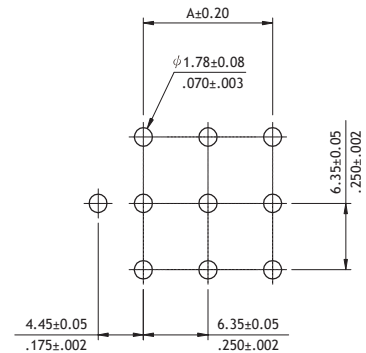
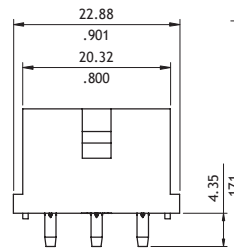
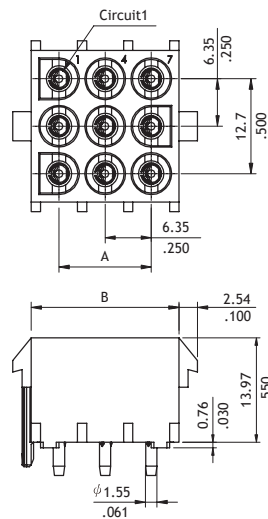
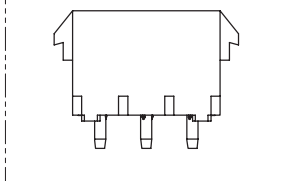

Recommended P.C.B oard layout

**Ordering Code**

① ② ③ ④ ⑤ ⑥ ⑦ ⑧  
**CP08 06 P 1 V D P - N**

- ① Series No.
- ② No. of Circuits: 06, 09, 12, 15
- ③ Contact Type : P = Plug
- ④ Plating Code : 1 = Tin over Nickel

- ⑤ Type: V= Straight Type
- ⑥ Material: D = Nylon 66 , UL 94V-0 (Triple Row)
- ⑦ Other Options : P = Male contact  
S = Female contact
- ⑧ N = Without Peg  
\*Code 8 for without peg type only

## CPF1 Series High-Voltage Plug Connectors

- ⊙ Mate with CPB2 Connectors
- ⊙ Can be used CPB2 Crimp Clip Pug terminal
- ⊙ Insulator : PBT UL 94V-0 , Color Nature
- ⊙ According to IEC 60529 IPX7

RoHS Compliant

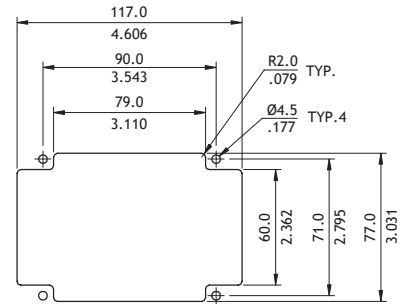
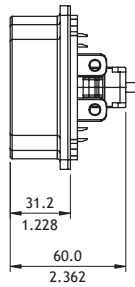
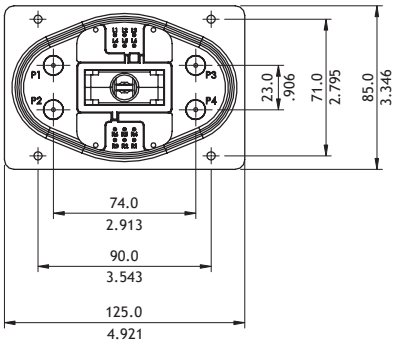
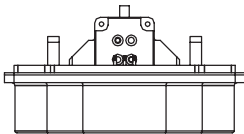
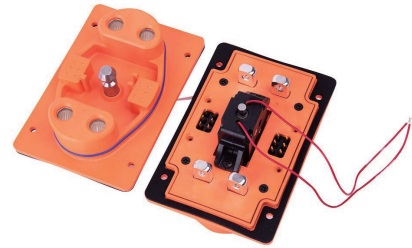

Recommended Panel Cutout (Front Mounting)

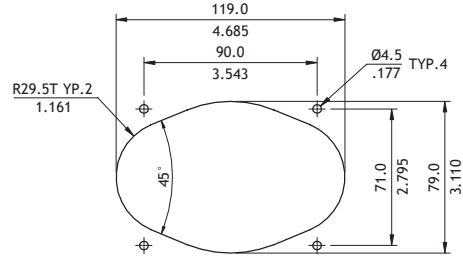

Recommended Panel Cutout (Rear Mounting)

ForU L1 977  
P/N: CPF14150SPA94BP1-0

ForU L4 128  
P/N: CPF14150SPA94BP1-A  
Recommended Application

ForU L4 128  
P/N: CPF14300SPA94BP1-B  
Recommended Application  
(Parallel Mode)

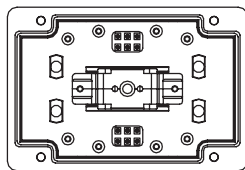

BACK VIEW

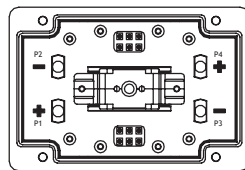

BACK VIEW A

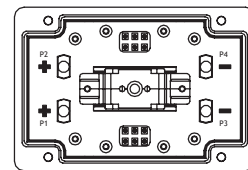

BACK VIEW B

### Ordering Code

① ② ③ ④ ⑤ ⑥ ⑦ ⑧ ⑨ ⑩ ⑪ ⑫  
**CPF1 4 150 S P A 9 4 B P 1 - A**

- ① Series No.
- ② No. of Circuits: 4, 2
- ③ Current : 150 = 150A(Per Pin)  
300=The two assigned pins of the connector (P1 and P2, P3 and P4) can be connected for parallel output to increase the total current up to 300A
- ④ Power pin plating : S = Silver plated
- ⑤ ConnectorType : P=Plug
- ⑥ SignalType : A = 6+6 B = 6+USBC(USB 3.2 Gen2)  
C = 6+0

- ⑦ Signal Pin plating: 9 = 5μ" Gold plated over 50μ"Nickel
- ⑧ Insulator color : 4 = Orange
- ⑨ Lock Type :  
0 = W/O Lock (2 in 1 Series)  
A = With Lock (Two-way solenoid valve)  
B = With Lock (One-way solenoid valve)
- ⑩ Prevention key option : 0 = W/O key, P = With Key
- ⑪ Options: 0 = Front & Rear Mounting all available  
1 = Front Mounting, 2 = Rear Mounting
- ⑫ Product Safety Certification : -0 for UL1977  
-A for UL4128(See back View A)  
-B for UL4128(See back View B)

**CPF1 Series High-Voltage Plug Connectors**

- ⊙ Mate with CPB2 Connectors
- ⊙ Can be used CPB2 Crimp Clip Pug terminal
- ⊙ Insulator : PBT UL 94V-0 , Color Nature
- ⊙ According to IEC 60529 IPX7

RoHS Compliant 

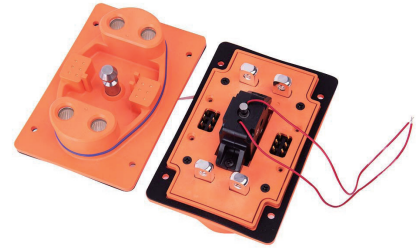

CP

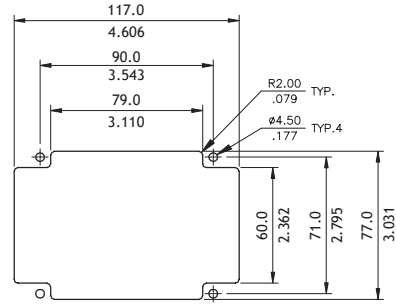
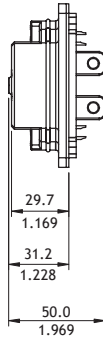
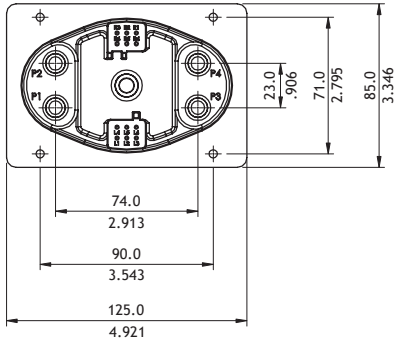
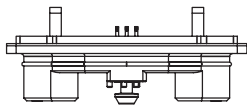

Recommended Panel Cutout (Front Mounting)

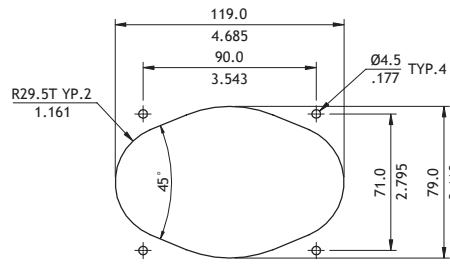

Recommended Panel Cutout (Rear Mounting)

For U L1 977

P/N: C PF14150SSA94BP0-0

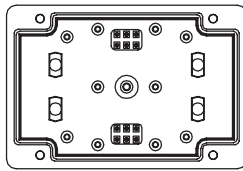

BACK VIEW

For U L4 128

P/N: CPF14150SSA94BP0-A  
Recommended Application

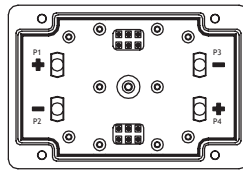

BACK VIEW A

For U L4 128

P/N: CPF14300SSA94BP0-B  
Recommended Application (Parallel Mode)

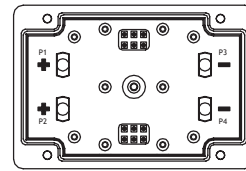

BACK VIEW B

**Ordering Code**

① CPF1 ② 4 ③ 150 ④ S ⑤ S ⑥ A ⑦ 9 ⑧ 4 ⑨ B ⑩ P ⑪ 1 ⑫ - A

- ① Series No.
- ② No. of Circuits: 4, 2
- ③ Current : 150 = 150A(Per Pin)  
300=The two assigned pins of the connector (P1 and P2, P3 and P4) can be connected for parallel out put to increase the total current up to 300A
- ④ Power pin plating : S = Silver plated
- ⑤ Connector Type : S = Receptacle
- ⑥ Signal Type : A = 6+6 B = 6+USBC(USB 3.2 Gen2)  
C = 6+0

- ⑦ Signal Pin plating: 9 = 5μ" Gold plated over 50μ"Nickel
- ⑧ Insulator color : 4 = Orange
- ⑨ Lock Type :  
0 = W/O Lock (2 in 1 Series)  
A = With Lock (Two-way solenoid valve)  
B = With Lock (One-way solenoid valve)
- ⑩ Prevention key option : 0 = W/O key, P = With Key
- ⑪ Options: 0 = Front & Rear Mounting all available  
1 = Front Mounting, 2 = Rear Mounting
- ⑫ Product Safety Certification : -0 for UL1977  
-A for UL4128(See back View A)  
-B for UL4128(See back View B)

## CPF2 Series High-Voltage Plug Connectors

- ⊙ Mate with CPB2 Connectors
- ⊙ Can be used CPB2 Crimp Clip Pug terminal
- ⊙ Insulator : PBT UL 94V-0 , Color Nature
- ⊙ According to IEC 60529 IPX7

RoHS Compliant

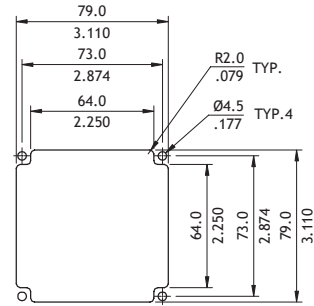
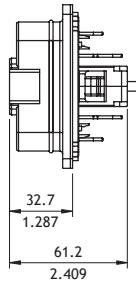
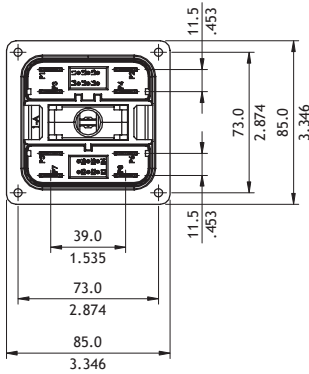
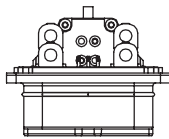

Recommended Panel Cutout (Front Mounting)

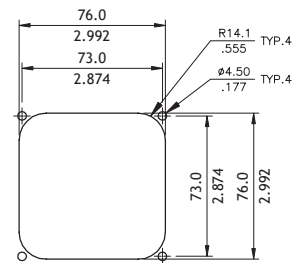

Recommended Panel Cutout (Rear Mounting)

ForU L1 977

P/N: CPF28075SPA94BP0-0

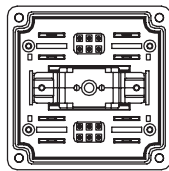

BACK VIEW

ForU L4 128

P/N: CPF28075SPA94BP0-A  
Recommended Application

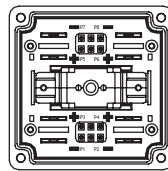

BACK VIEW A

ForU L4 128

P/N: CPF24075SPA94BP0-B  
Recommended Application  
(Parallel Mode)

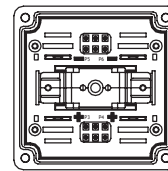

BACK VIEW B

### Ordering Code

① ② ③ ④ ⑤ ⑥ ⑦ ⑧ ⑨ ⑩ ⑪ ⑫  
**CPF2 8 075 S P A 9 4 B P 0 - A**

- ① Series No.
- ② No. of Circuits: 8, 4
- ③ Current : 075 = 75A
- ④ Power pin plating : S = Silver plated
- ⑤ ConnectorType : P = Plug
- ⑥ SignalType : A = 6+6 B = 6+USBC(USB 3.2 Gen2)  
C = 6+0
- ⑦ Signal Pin plating: 9 = 5μ" Gold plated over 50μ"Nickel

- ⑧ Insulator color : 4 = Orange
- ⑨ Lock Type :  
0 = W/O Lock (2 in 1 Series)  
A = With Lock (Two-way solenoid valve)  
B = With Lock (One-way solenoid valve)
- ⑩ Prevention key option : 0 = W/O key , P = With Key
- ⑪ Options: 0 = Front & Rear Mounting all available  
1 = Front Mounting , 2 = Rear Mounting
- ⑫ Product Safety Certification : -0 for UL1977  
-A for UL4128(See back View A)  
-B for UL4128(See back View B)

CPF2 Series High-Voltage Plug Connectors

- ⊙ Mate with CPB2 Connectors
- ⊙ Can be used CPB2 Crimp Clip Pug terminal
- ⊙ Insulator : PBT UL 94V-0 , Color Nature
- ⊙ According to IEC 60529 IPX7

RoHS Compliant 



CP

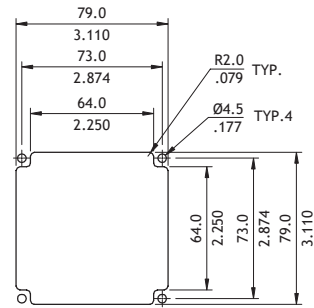
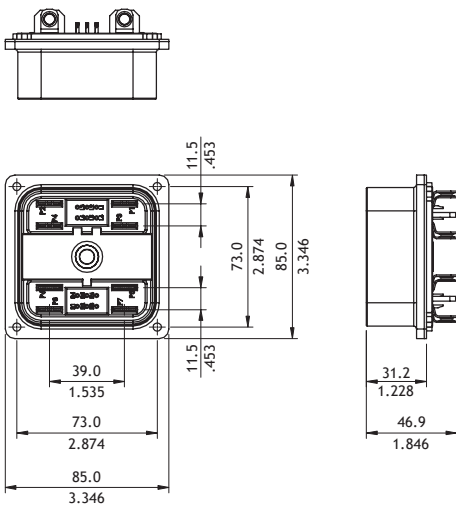

Recommended Panel Cutout (Front Mounting)

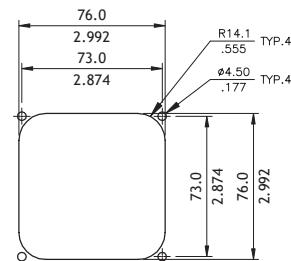

Recommended Panel Cutout (Rear Mounting)

For U L1 977  
P/N: CPF28075SSA94BP1-0

For U L4 128  
P/N: CPF28075SSA94BP1-A  
Recommended Application

For U L4 128  
P/N: CPF24075SSA94BP1-B  
Recommended Application  
(Parallel Mode)

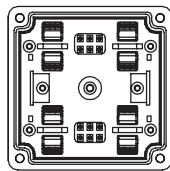

BACK VIEW

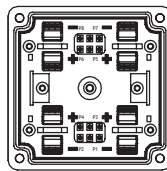

BACK VIEW A

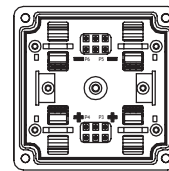

BACK VIEW B

Ordering Code

① ② ③ ④ ⑤ ⑥ ⑦ ⑧ ⑨ ⑩ ⑪ ⑫  
**CPF2 8 075 S S A 9 4 B P 0 - A**

- ① Series No.
- ② No. of Circuits: 8, 4
- ③ Current : 075 = 75A
- ④ Power pin plating : S = Silver plated
- ⑤ Connector Type : S = Receptacle
- ⑥ Signal Type : A = 6+6 B = 6+USBC(USB 3.2 Gen2)  
C = 6+0
- ⑦ Signal Pin plating: 9 = 5µ" Gold plated over 50µ"Nickel

- ⑧ Insulator color : 4 = Orange
- ⑨ Lock Type :  
0 = W/O Lock (2 in 1 Series)  
A = With Lock (Two-way solenoid valve)  
B = With Lock (One-way solenoid valve)
- ⑩ Prevention key option : 0 = W/O key , P = With Key
- ⑪ Options: 0 = Front & Rear Mounting all available  
1 = Front Mounting , 2 = Rear Mounting
- ⑫ Product Safety Certification : -0 for UL1977  
-A for UL4128(See back View A)  
-B for UL4128(See back View B)

**Connection Combination of IDC Connectors**

1.27 Pitch Female IDC Cable  
(Board in)

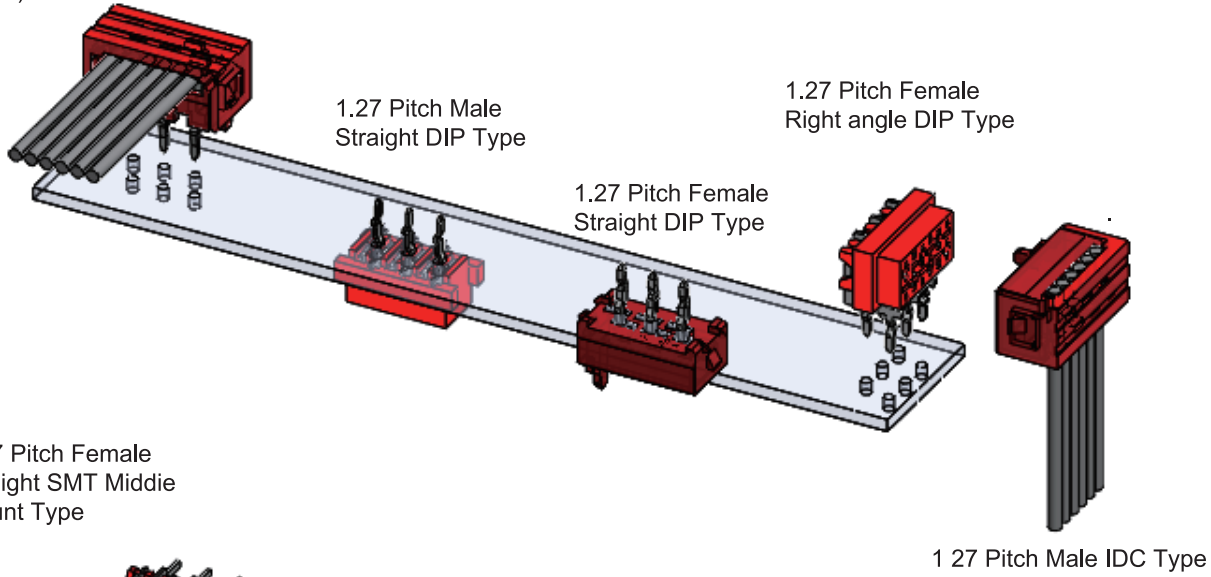

1.27 Pitch Female IDC Cable

1.27 Pitch Female IDC Cable  
(Board in )

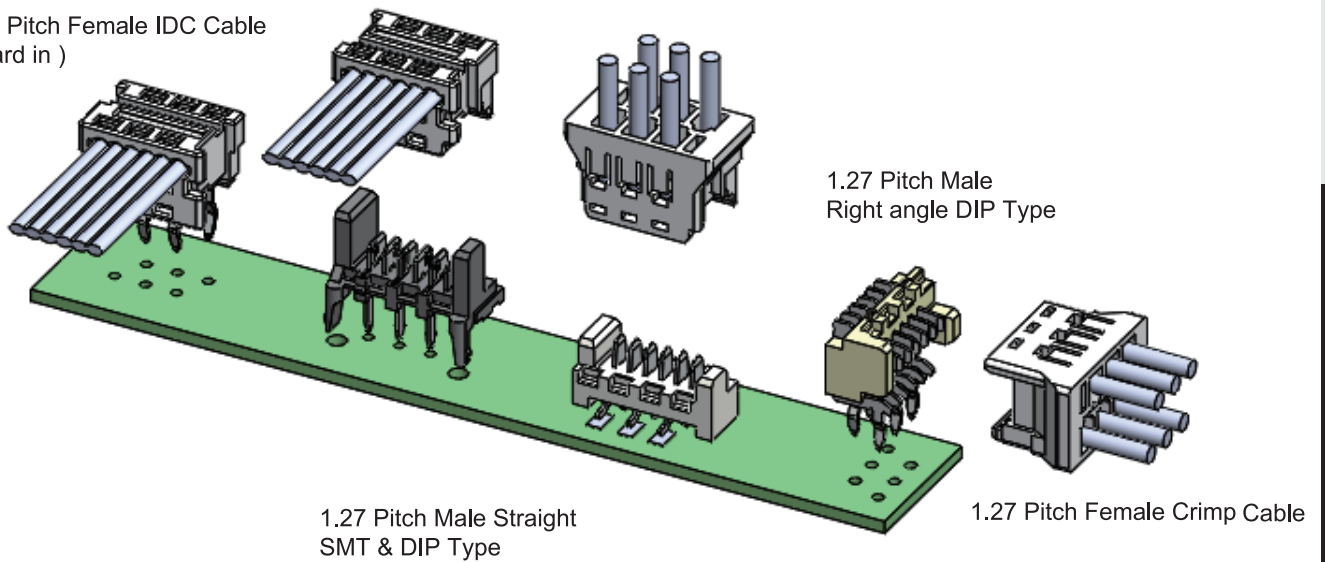

CA

IDC CONNECTORS

CA30 Series 1.27mm(.050") Male IDC & DIP Type Connectors

- ⊙ Can be used with CW03 1.27mm(.050") center spacing flat ribbon cable.
- ⊙ Mate with CA32 connector

RoHS Compliant 

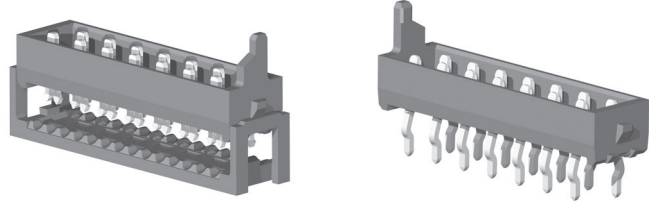

IDC Type

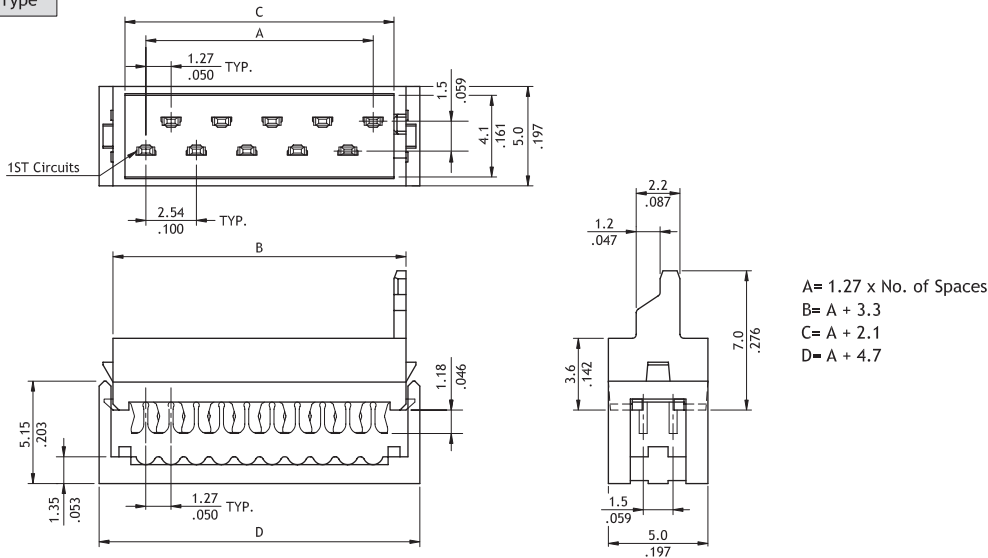

DIP Type

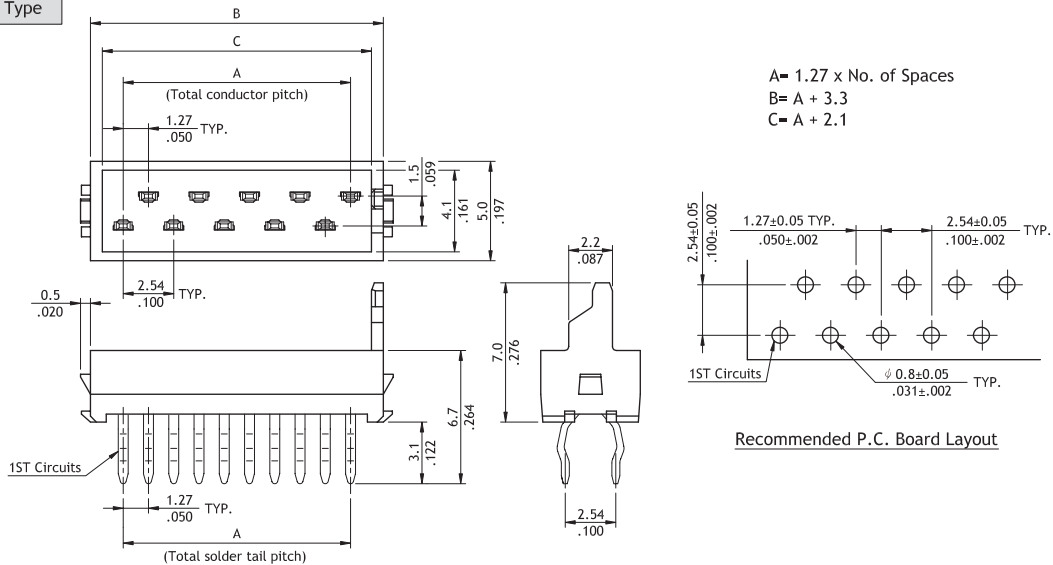

Ordering Code

① ② ③ ④ ⑤ ⑥ ⑦  
**CA30 26 P 1 3 0 0**

- ① Series No.
- ② No. of Circuits: 04 ~ 26
- ③ Contact Type: P = Plug
- ④ Plating Code:  
 1 = Matte Tin over Nickel  
 \*Optional plating available but MOQ requested

- ⑤ Color: 3 = Red
- ⑥ Type: 0 = DIP Type  
 I = IDC Type
- ⑦ Other Options:  
 0 = Standard  
 \*Special options consult manufacturer

**CA30 Series 1.27mm(.050") Male SMT Type Connectors**

- ☉ Mate with CA32 connector
- ☉ High temperature plastic UL 94V-0, color red

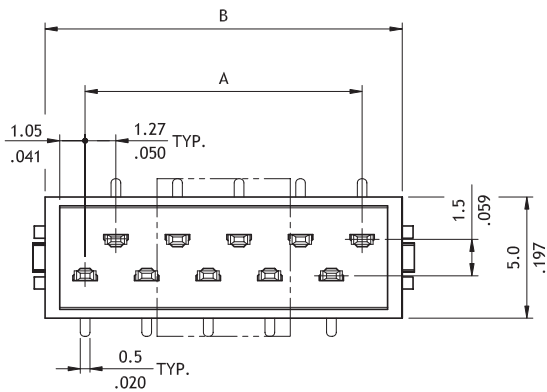
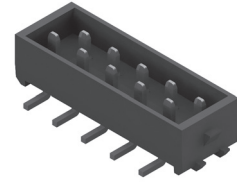

A = 1.27 x No. of Spaces  
B = A + 3.3

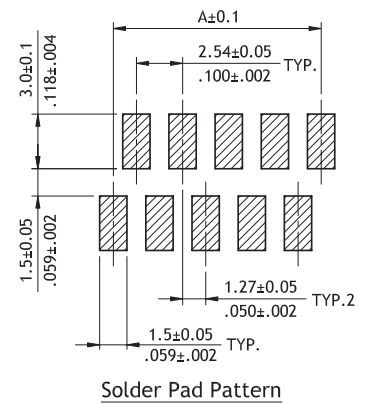
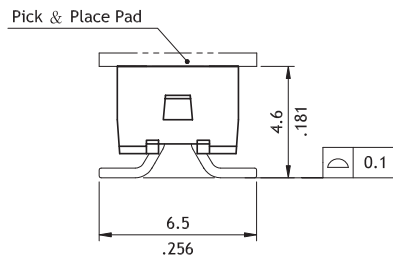
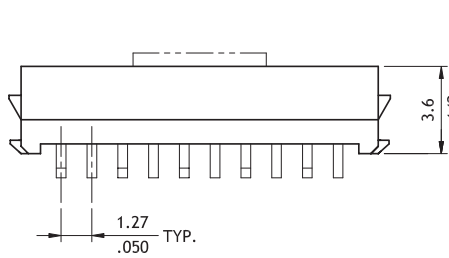

**Ordering Code**

①	②	③	④	⑤	⑥
CA30	26	M	1	3	R0

- ① Series No.
- ② No. of Circuits: 04 ~ 26
- ③ Contact Type: M = SMT
- ④ Plating Code:  
1 = Matte Tin over Nickel  
\*Optional plating available but MOQ requested

- ⑤ Color: 3 = Red
- ⑥ Packing Options:  
R0 = With PAD ;Tape & Reel Packing  
RN = Without PAD ;Tape & Reel Packing  
T0 = Without PAD ;Tube Packing  
\*Special options consult manufacturer

**CA31 Series 1.27mm(.050") Flat Cable - IDC DIP Type Connectors**

© Can be used with CW03 1.27mm(.050") center spacing flat ribbon cable.

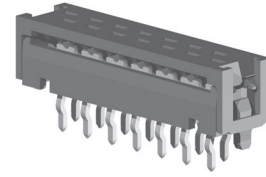

CA

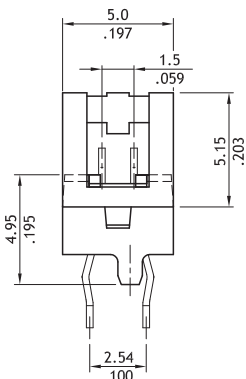
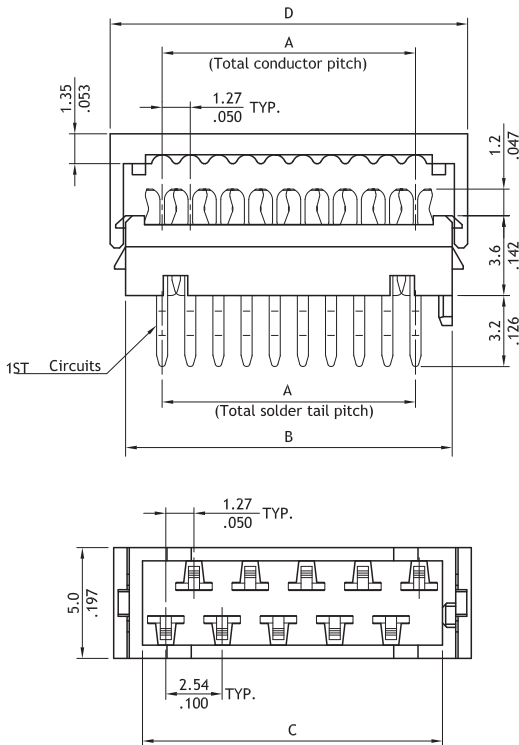

A = 1.27 x No. of Spaces  
 B = A + 3.3  
 C = A + 2.1  
 D = A + 4.7

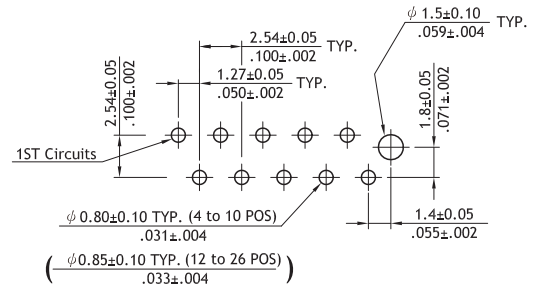

Recommended PCB Layout

**Ordering Code**

①	②	③	④	⑤	⑥
CA31	26	P	1	3	00

- ① Series No.
- ② No. of Circuits: 04 ~ 26
- ③ Contact Type:P=Plug
- ④ Plating Code:  
1 = Matte Tin over Nickel  
\*Optional plating available but MOQ requested

- ⑤ Color: 3 = Red
- ⑥ Other Options:  
00=Standard  
\*Special options consult manufacturer

IDC CONNECTORS

**CA30 & CA31 Series Flat Cable Assemblies**

Compact and low profile IDC connector with 1.27mm pitch flat cable assembly combinations.

With full range connectors produced in house, Cvilux is fully equipped to provide cost-effective and high quality flat cble assemblies.

Furthermore, integrated production and assembly process can save your time to market and increase more profit.

Please check below sketch for all kinds of options and advice more details (length, stripped,red line positions, polarizing direction....etc.) we will follow up your request accordingly.

Consult CviLux sales person if customized assembly required.

TYPE A	TYPE B	TYPE C	TYPE D
TYPE E	TYPE F	TYPE G	TYPE H
TYPE J	TYPE K	TYPE M	TYPE N
TYPE P	TYPE Q	TYPE R	TYPE S

CA

IDC CONNECTORS

CA32 Series 1.27mm(.050") Female DIP Type Connectors

☉ Mate with CA30 connector

RoHS Compliant 

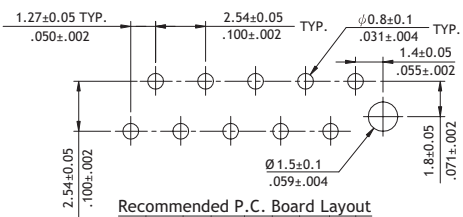
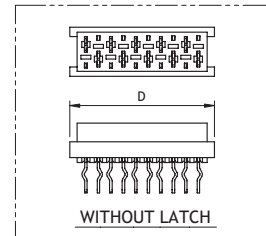
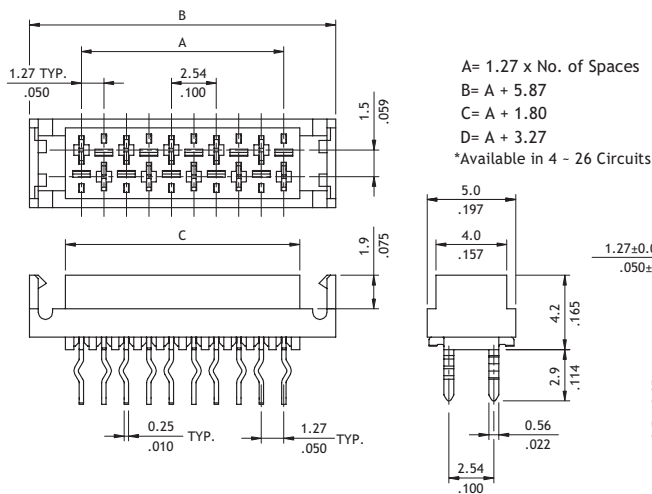
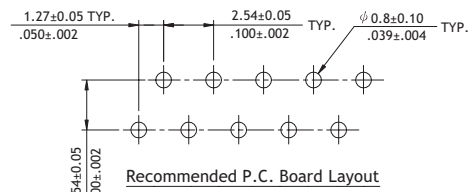
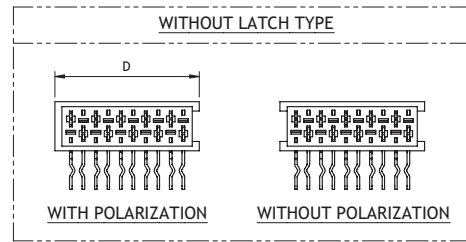
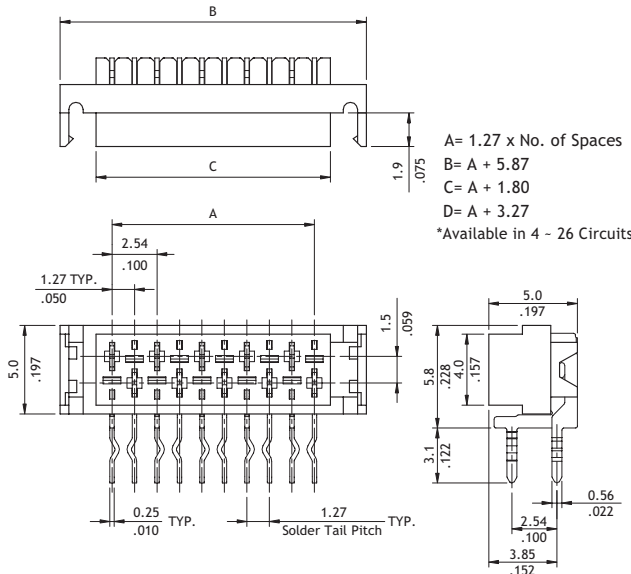
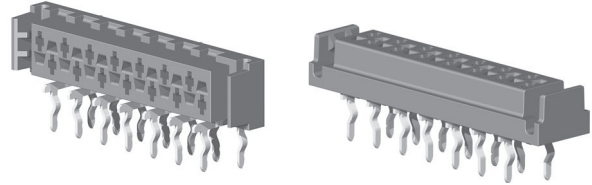

Ordering Code

① ② ③ ④ ⑤ ⑥  
**CA32 26 H 1 3 00**

- ① Series No.
- ② No. of Circuits: 04 ~ 26
- ③ Contact Type: V = Straight  
H = Right Angle
- ④ Plating Code:  
1 = Matte Tin over Nickel  
\*Optional plating available but MOQ requested
- ⑤ Color: 3 = Red

- ⑥ Right Angle Type:  
00 = Without Latch & With Polarization  
S0 = Without Latch & Without Polarization  
OL = With Latch
- Straight Type:  
00 = Without Latch  
OL = With Latch  
\*Special options consult manufacturer

CA

IDC CONNECTORS

**CA32 Series 1.27mm(.050") Female SMT Type Connectors**

- ⊙ Mate with CA30 connector
- ⊙ High temperature plastic UL 94V-0, color red

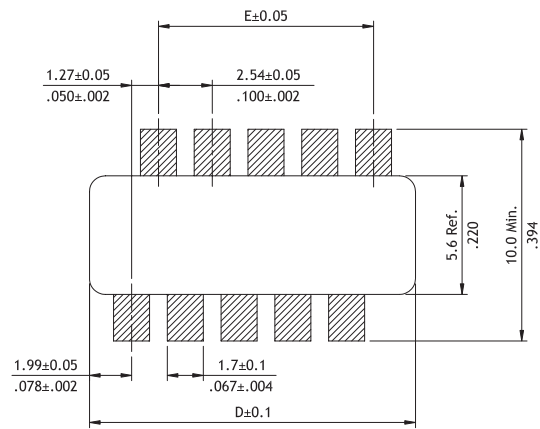
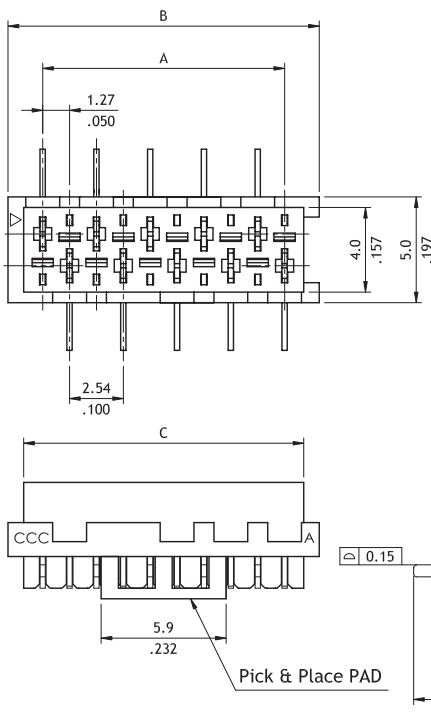
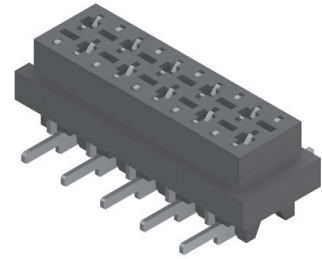

Recommended P.C. Board Layout

- A = 1.27 x No. of Spaces
- B = A + 3.28
- C = A + 1.80
- D = A + 3.97
- E = A - 1.27
- \*Available in 4 - 26 Circuits

**Ordering Code**

① ② ③ ④ ⑤ ⑥ ⑦  
**CA32 26 M 1 3 0 A**

- ① Series No.
- ② No. of Circuits: 04 ~ 26
- ③ Contact Type: M = SMT Type
- ④ Plating Code:  
 1 = Matte Tin over Nickel  
 \*Optional plating available but MOQ requested
- ⑤ Color: 3 = Red

- ⑥ Pad Options:  
 0 = With Pad (Reel Packing)
- ⑦ Other Options:  
 A = Middle mount type  
 0 = Top mount type (Without Latch)  
 L = Top mount type (With Latch)  
 \*Special options consult manufacturer

**CA33 Series 1.27mm(.050") IDC & Crimping Type Connectors**

- ⊙ Can be used CW03 1.27mm(.050") Center Spacing flat ribbon cable
- ⊙ Mate with CA35 Connectors
- ⊙ Can be used CA33 crimp clip terminal
- ⊙ Insulator: Glass Filled Polyester UL 94V-0, Color Nature



**RoHS** Compliant

**IDC Type**

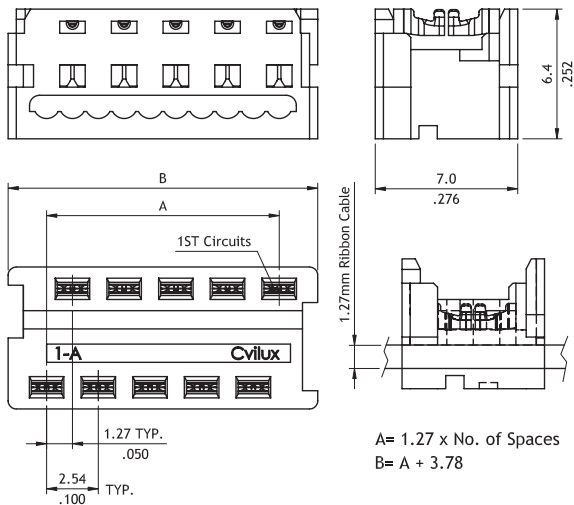

**Crimp Type Housing**

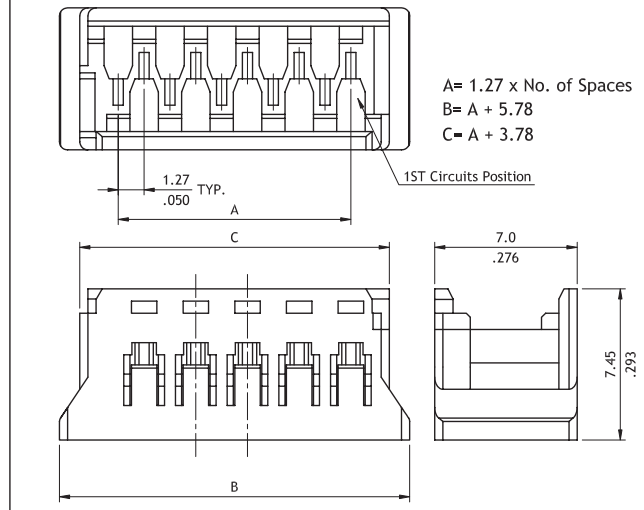

**Crimp Type Terminal**

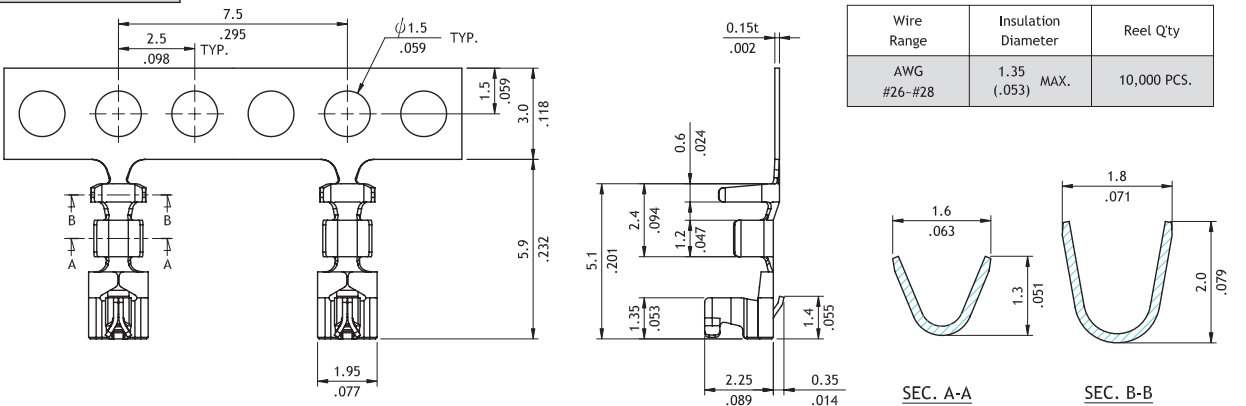

**Ordering Code**

① CA 33    ② 26    ③ P    ④ 1    ⑤ 0    ⑥ I    ⑦ 0    ⑧ - NH       ① CA 33    ② 26    ③ S00    ④ 0    ⑤ 0    ⑥ - NH

- ① Series No.
- ② No. of Circuits: 04 ~ 26
- ③ Contact Type:  
P = Pin Header
- ④ Plating Code:  
1 = Tin over Nickel
- ⑤ Color: 0 = Nature
- ⑥ Type: I = IDC Type
- ⑦ Other Options:  
0 = Standard (Tube Packing)
- ⑧ NH = Halogen-Free
- ① Series No.
- ② No. of Circuits: 04 ~ 26
- ③ Type: S00 = Housing
- ④ Color: 0 = Nature
- ⑤ Other Options: 0 = Standard
- ⑥ NH = Halogen-Free

CA

IDC CONNECTORS

## CM19A330000 Pull-off tongs for CA33

- ⊙ Steel and plastic construction with molded prongs
- ⊙ Long life spring steel handles
- ⊙ Designed for field use
- ⊙ This Extractor Tool is for the removal of CA33 series

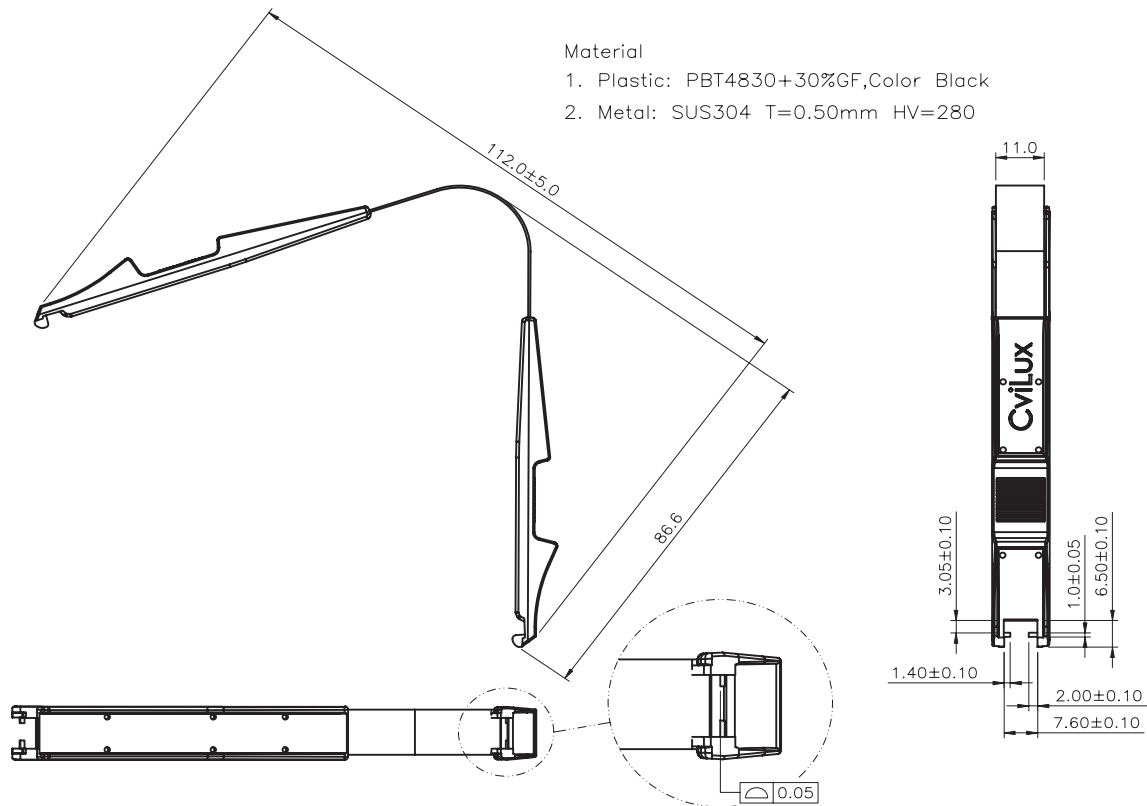

To remove a connector from the assembly

Please follow the steps below:

- ⊙ Hold the tool between the thumb and forefinger.
- ⊙ Push the tool together, the prongs are far enough apart to fit over the connector that is being extracted.
- ⊙ Squeeze the prongs together until the locator fingers are in the slots on the end wall of the connector.
- ⊙ While keeping the extractor tool engaged with the connector, pull the connector upright from the header softly.

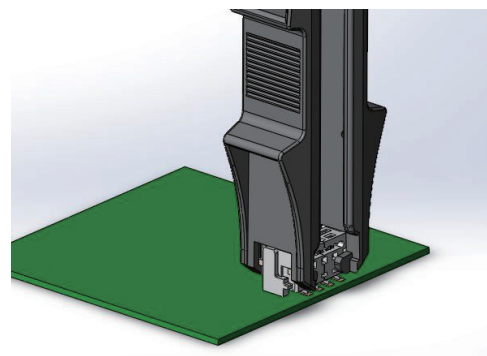
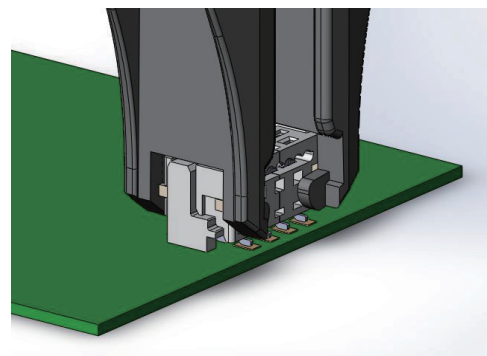

**CA34 Series 1.27mm(.050") Flat Cable - IDC DIP Plugs**

- ⊙ Can be used CW03 1.27mm(.050") Center Spacing flat ribbon cable
- ⊙ Insulator: Glass Filled Polyester UL 94V-0, Color Nature

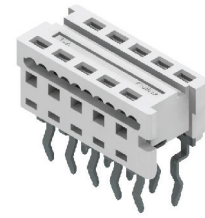

CA

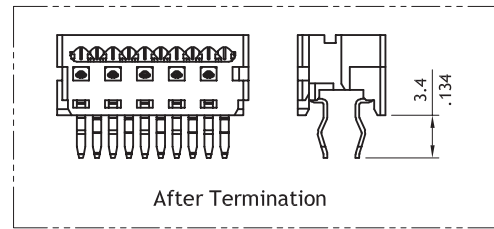
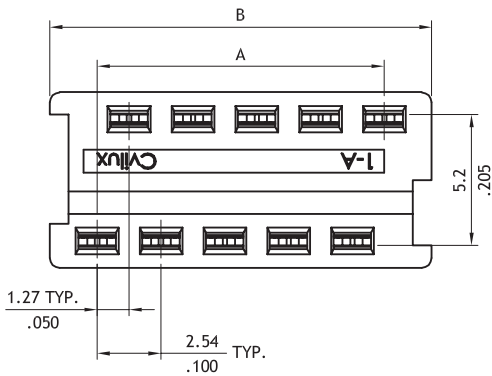

A = 1.27 x No. of Spaces  
B = A + 3.78

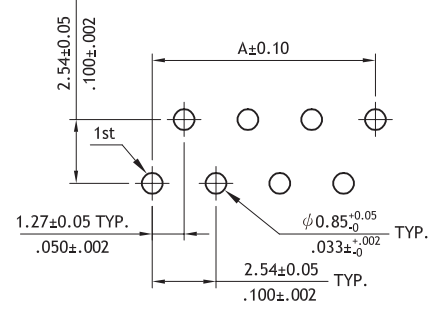
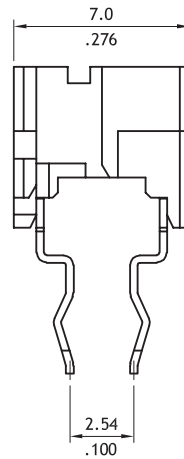
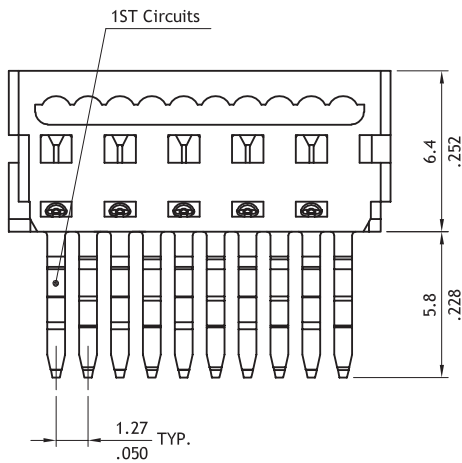

Recommended P.C. Board Layout

**Ordering Code**

① ② ③ ④ ⑤ ⑥ ⑦  
**CA34 26 P 1 0 00 - NH**

- ① Series No.
- ② No. of Circuits: 04 ~ 26
- ③ Contact Type:  
P = Pin Header

- ④ Plating Code:  
1 = Matte Tin over Nickel
- ⑤ Color: 0 = Nature
- ⑥ Other Options: 00 = Standard (Tube Packing)
- ⑦ NH = For Lead Free Process and Halogen-Free

IDC CONNECTORS

## CA35 Series 1.27mm(.050") Male DIP Type Connectors

- ☉ Mate with CA33 connectors
- ☉ Insulator: High temperature plastic UL 94V-0, Color Black

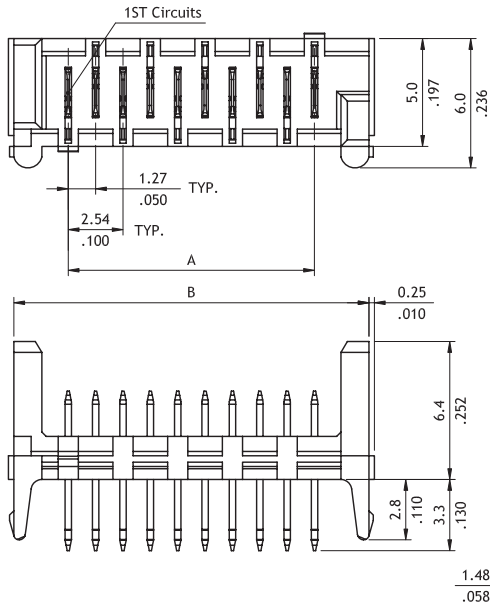
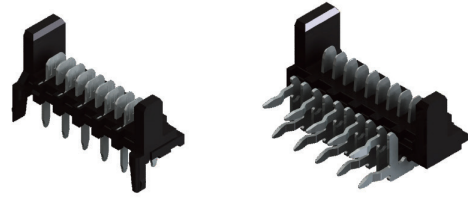

A = 1.27 x No. of Spaces  
B = A + 5.05

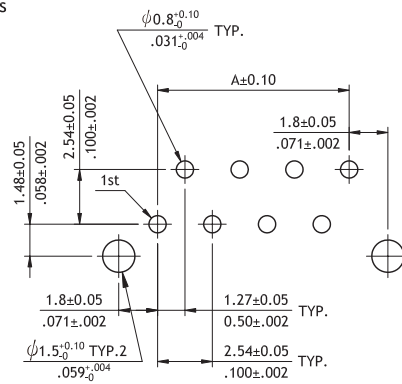

Recommended P.C. Board Layout

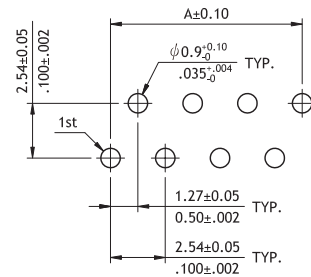
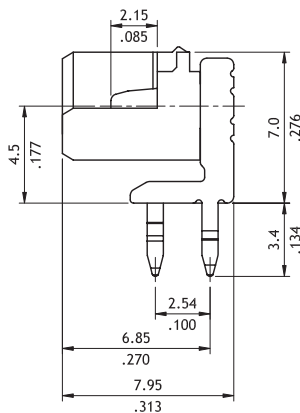
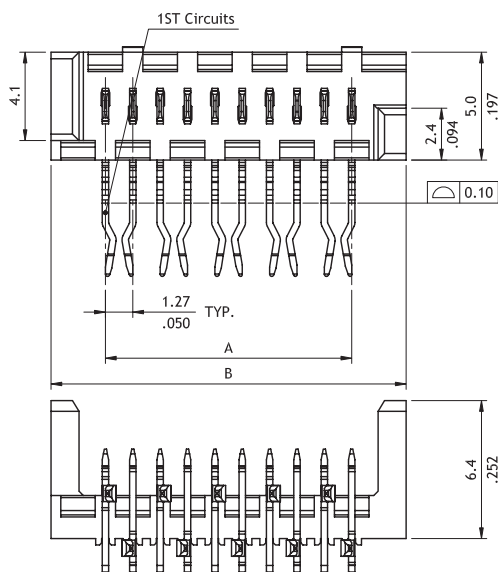

Recommended P.C. Board Layout

A = 1.27 x No. of Spaces  
B = A + 5.05

### Ordering Code

① ② ③ ④ ⑤ ⑥ ⑦  
CA35 26 V 1 1 00 - NH

- ① Series No.
- ② No. of Circuits: 04 ~ 26
- ③ Contact Type:  
V = Straight  
H = Right Angle

- ④ Plating Code:  
1 = Matte Tin over Nickel
- ⑤ Color: 1 = Black
- ⑥ Other Options: 00 = Standard
- ⑦ NH = For Lead Free Process and Halogen-Free

CA35 Series 1.27mm(.050") Male SMT Type Connectors

- ☉ Mate with CA33 connectors
- ☉ Insulator: High temperature plastic UL 94V-0, Nature

RoHS Compliant

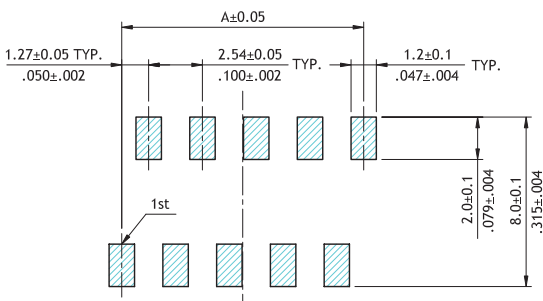
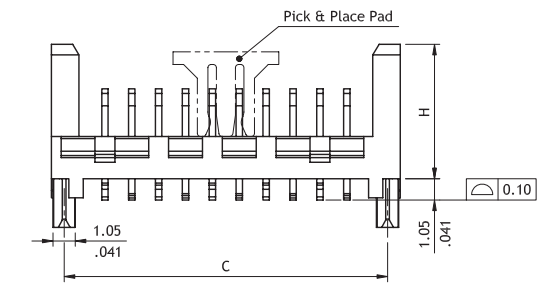
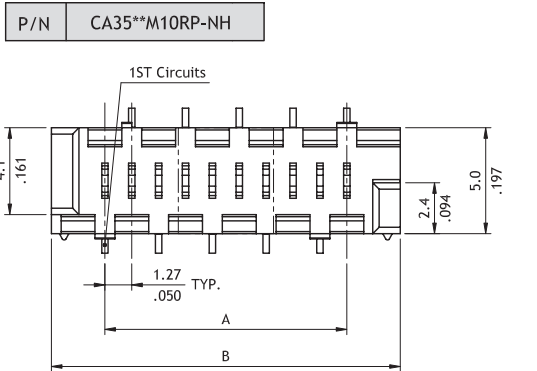
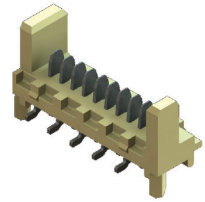

P.C.B Layout Headers Without Plastic Pegs

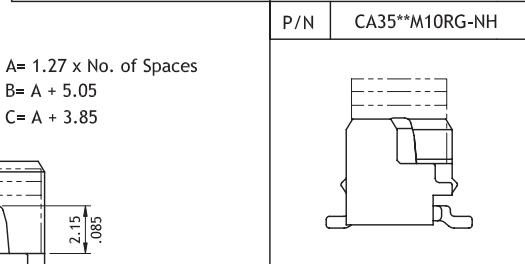
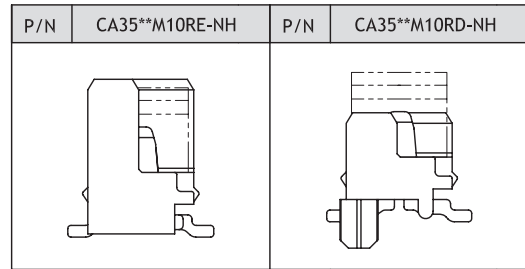

P/N	CA35**M10RE-NH	P/N	CA35**M10RD-NH
P/N	CA35**M10RG-NH		

A = 1.27 x No. of Spaces  
 B = A + 5.05  
 C = A + 3.85

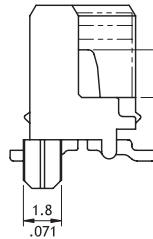

Transition Fit With P.C.B Pegs	K = 1.75
Clearance Fit With P.C.B Pegs	K = 2.0

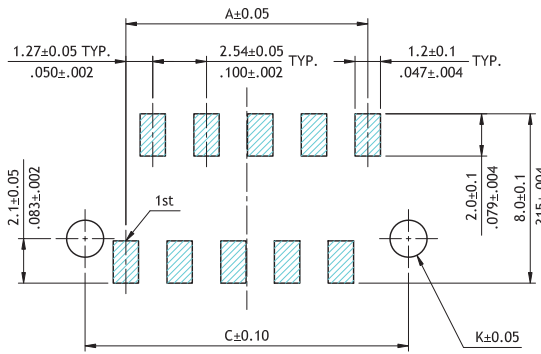

P.C.B Layout Headers With Plastic Pegs

Ordering Code

① ② ③ ④ ⑤ ⑥ ⑦ ⑧  
**CA35 26 M 1 0 R P - NH**

- ① Series No.
- ② No. of Circuits: 04 ~ 26
- ③ Contact Type:  
M = SMT Type
- ④ Plating Code:  
1 = Matte Tin over Nickel

- ⑤ Color: 0 = Nature
- ⑥ Packing Options:  
R = Tape & Reel (With pick & place pad)  
T = Tube  
0 = Bags

- ⑦ Other Options:  
G = Without positioning pegs, H = 4.10mm  
D = With positioning pegs, H = 4.10mm  
E = Without positioning pegs, H = 6.40mm  
P = With positioning pegs, H = 6.40mm
- ⑧ NH = For Lead Free IR Process and Halogen-Free

CA

IDC CONNECTORS

**CA35 Series 1.27mm(.050") Female DIP Type Connectors**

- ☉ Mate with CA33 connectors
- ☉ Insulator: High temperature plastic UL 94V-0, Nature

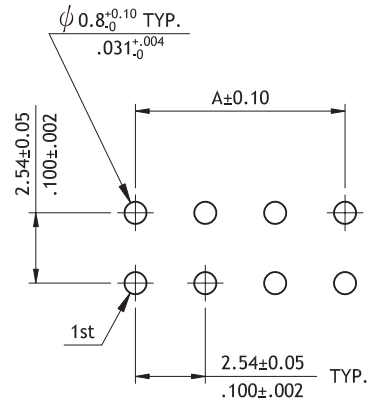
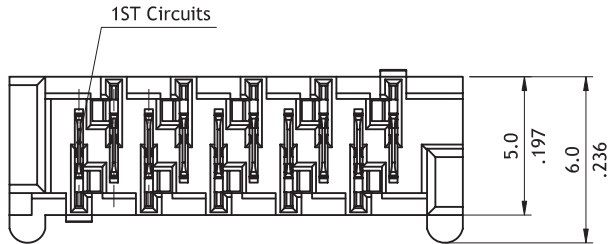
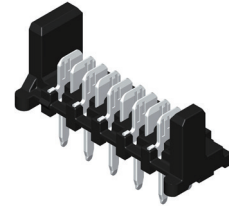

Recommended P.C. Board Layout

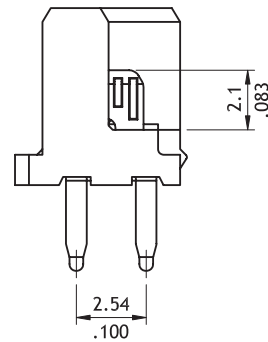
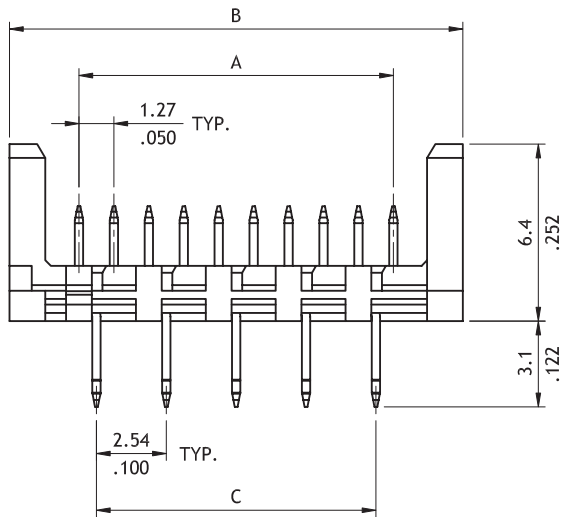

A= 1.27 x No. of Spaces  
 B= A + 5.05  
 C= 2.54 x No. of Spaces

**Ordering Code**

① ② ③ ④ ⑤ ⑥ ⑦  
**CA35 26 V 1 1 0B - NH**

- ① Series No.
- ② No. of Circuits: 04 ~ 26
- ③ Contact Type:  
V = Straight Type
- ④ Plating Code:  
1 = Matte Tin over Nickel
- ⑤ Color: 1 = Black
- ⑥ Options: 0B = Type B
- ⑦ NH = For Lead Free Process and Halogen-Free

## CW03 Series 1.27mm(.050") Flat Ribbon Cable

**UL GRADE:**

UL STYLE: 2651

Rate temperature: 105 degree celsius

Rate voltage: 300V

Flame Test: VW -1

**CONDUCTOR:Standard**

AWG size: 28 AWG

Number of strands in each conductor: 7/0.127mm

**ELECTRICAL CHARACTERISTICS:**

Spark test: 2500V

Dielectric strength test: Min. 2KV in 1 minute

Conductor resistance: Max. 237 ohm/km

Insulation resistance: Min. 1G ohm/m

Capacity: 45 PF/m

Inductance: 1.45 uH/m

Impedance: 100 ohm

Propagation Delay Time: 4.2 ns/m

**INSULATION:**

Material of insulation: PVC, Color Gray

**PHYSICAL PROPERTIES:**

after 7 days air oven at 136 degree celsius

Average tensile strength: 1500 lbs/inch

Percent of original: 70% at least

Average elongation: 200%

Percent of original: 65% at least



P/N : CW03\*\*D900A

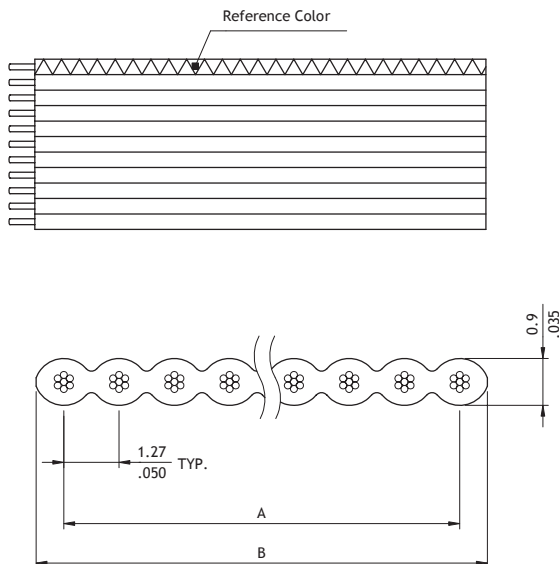

Circuits	Dimension	
	A	B
8	8.89(.350)	10.16(.400)
9	10.16(.400)	11.43(.450)
10	11.43(.450)	12.70(.500)
12	13.97(.550)	15.24(.600)
14	16.51(.650)	17.78(.700)
15	17.78(.700)	19.05(.750)
16	19.05(.750)	20.32(.800)
17	20.32(.800)	21.59(.850)
18	21.59(.850)	22.86(.900)
20	24.13(.950)	25.40(1.000)
24	29.21(1.150)	30.48(1.200)
25	30.48(1.200)	31.75(1.250)
26	31.75(1.250)	33.02(1.300)
28	34.29(1.350)	35.56(1.400)
30	36.83(1.450)	38.10(1.500)
32	39.37(1.550)	40.64(1.600)
34	41.91(1.650)	43.18(1.700)
36	44.45(1.750)	45.72(1.800)
38	46.99(1.850)	48.26(1.900)
40	49.53(1.950)	50.80(2.000)
50	62.23(2.540)	63.50(2.500)
60	74.93(2.950)	76.20(3.000)
64	80.01(3.150)	81.28(3.200)

## CA11 Series 2.00mm(.079") Center Spacing Flat Cable - IDC Sockets

- ☉ Mate with CH71, CH75 and CH74 headers
- ☉ Can be used with CW02 1.00mm(.039") Center Spacing flat ribbon cable

RoHS Compliant

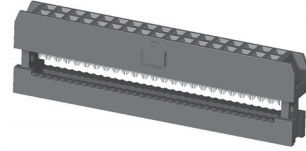

P/N CA11\*\*SA1\*0

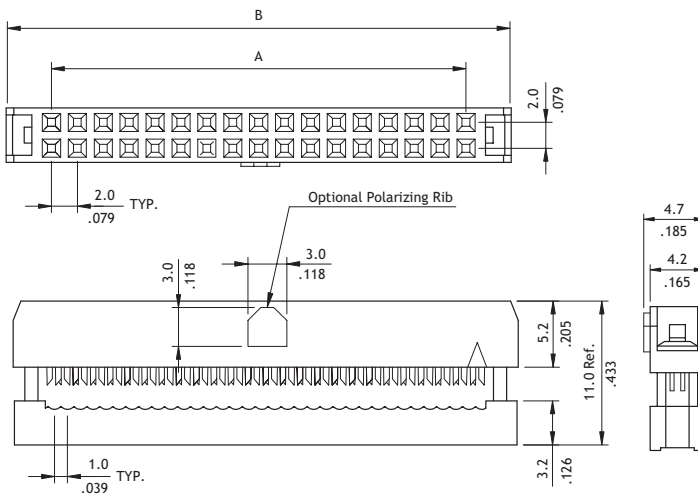

Circuits	Dimension		
	A	B	C
6	4.0(.157)	11.2(.441)	11.2(.441)
8	6.0(.236)	13.2(.520)	13.2(.520)
10	8.0(.315)	15.2(.598)	15.2(.598)
12	10.0(.394)	17.2(.677)	17.2(.677)
14	12.0(.472)	19.2(.756)	19.2(.756)
16	14.0(.551)	21.2(.835)	21.2(.835)
20	18.0(.709)	25.2(.992)	25.2(.992)
22	20.0(.787)	27.2(1.071)	27.2(1.071)
24	22.0(.866)	29.2(1.150)	29.2(1.150)
26	24.0(.945)	31.2(1.228)	31.2(1.228)
30	28.0(1.102)	35.2(1.386)	35.2(1.386)
32	30.0(1.181)	37.2(1.465)	37.2(1.465)
34	32.0(1.260)	39.2(1.543)	39.2(1.543)
36	34.0(1.339)	41.2(1.622)	41.2(1.622)
40	38.0(1.496)	45.2(1.780)	45.2(1.780)
44	42.0(1.654)	49.2(1.937)	49.2(1.937)
50	48.0(1.890)	55.2(2.173)	55.2(2.173)
60	58.0(2.283)	65.2(2.567)	65.2(2.567)
64	62.0(2.441)	69.2(2.724)	69.2(2.724)

P/N CA11\*\*SR100

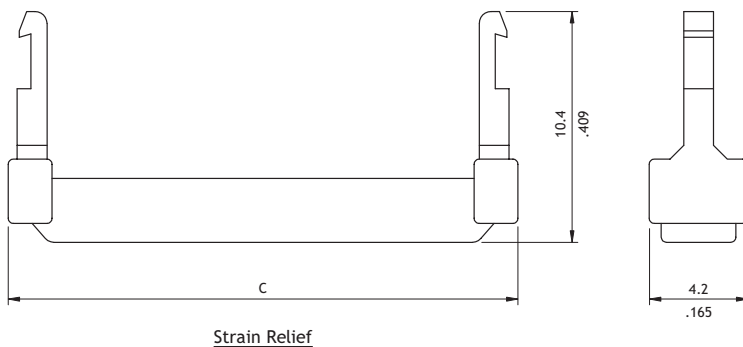

### Ordering Code

① CA 11 ② 6 4 ③ S ④ A ⑤ 1 ⑥ 0 0

- ① Series No.
- ② No. of Circuits: See above table
- ③ Contact Type: S = Socket
- ④ Plating Code : A = Selective Gold flash over Nickel  
\*Optional plating available but MOQ requested
- ⑤ Color: 1 = Black
- ⑥ Other Options : 00 = With polarizing rib (Standard)  
A0 = Without polarizing rib  
\*Special options consult manufacturer

① CA 11 ② 6 4 ③ SR ④ 100

- ① Series No.
- ② Contacts: See above table
- ③ SR = Strain-Relief
- ④ Color: 100 = Black

**CA21 Series 2.54mm(.100") Center Spacing Flat Cable - IDC Sockets**

- ⊙ Mate with CH81, CH84, CH87 and CH88 Headers
- ⊙ Can be used with CW03 1.27mm(.050") Center Spacing flat ribbon cable

RoHS Compliant

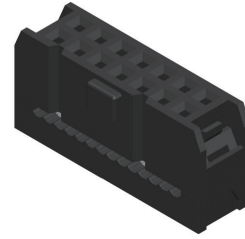

P/N CA21\*\*SA1\*0

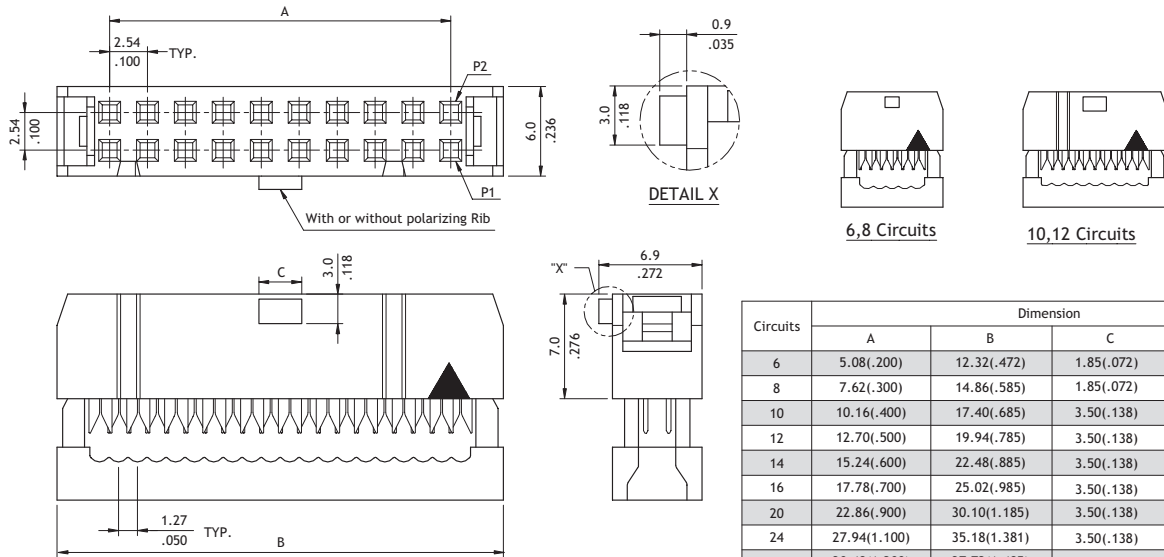

Circuits	Dimension			
	A	B	C	D
6	5.08(.200)	12.32(.472)	1.85(.072)	12.2(.480)
8	7.62(.300)	14.86(.585)	1.85(.072)	14.7(.579)
10	10.16(.400)	17.40(.685)	3.50(.138)	17.3(.681)
12	12.70(.500)	19.94(.785)	3.50(.138)	19.8(.780)
14	15.24(.600)	22.48(.885)	3.50(.138)	22.3(.878)
16	17.78(.700)	25.02(.985)	3.50(.138)	24.9(.980)
20	22.86(.900)	30.10(1.185)	3.50(.138)	30.0(1.181)
24	27.94(1.100)	35.18(1.381)	3.50(.138)	35.0(1.378)
26	30.48(1.200)	37.72(1.485)	3.50(.138)	37.6(1.480)
30	35.56(1.400)	42.80(1.685)	3.50(.138)	42.7(1.681)
34	40.64(1.600)	47.88(1.885)	3.50(.138)	47.7(1.878)
36	43.18(1.700)	50.42(1.985)	3.50(.138)	50.2(1.976)
40	48.26(1.900)	55.50(2.185)	3.50(.138)	55.4(2.181)
44	53.34(2.100)	60.58(2.385)	3.50(.138)	60.4(2.378)
50	60.96(2.400)	68.20(2.685)	3.50(.138)	68.1(2.681)

P/N CA21\*\*SR100

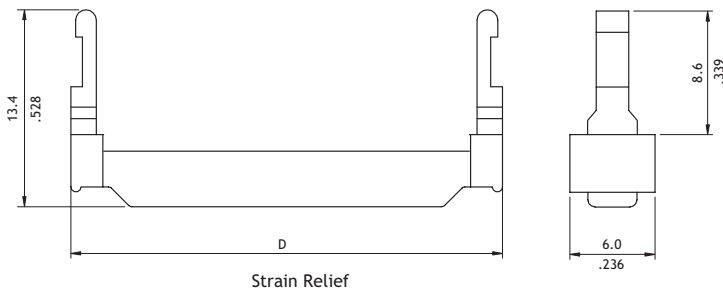

**Ordering Code**

① ② ③ ④ ⑤ ⑥  
**CA 2 1 5 0 S A 1 0 0**

① ② ③ ④  
**CA 2 1 5 0 S R 1 0 0**

- ① Series No.
- ② No. of Circuits: See above table
- ③ Contact Type: S = Socket
- ④ Plating Code : A = Selective Gold flash over Nickel  
 \*Optional plating available but MOQ requested
- ⑤ Color: 1 = Black
- ⑥ Other Options: 00 = With polarizing rib(Standard)  
 A0 = Without polarizing rib  
 \*Special options consult manufacturer

- ① Series No.
- ② Contacts: See above table
- ③ SR = Strain-Relief
- ④ Color: 100 = Black

**CA23 Series 2.54mm(.100") Center Spacing Flat Cable - IDC DIP Plugs**

© Can be used with CW03 1.27mm(.050) Center Spacing flat ribbon cable

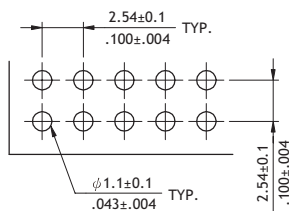
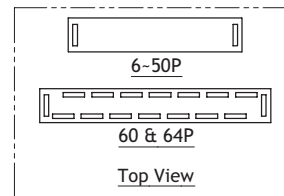
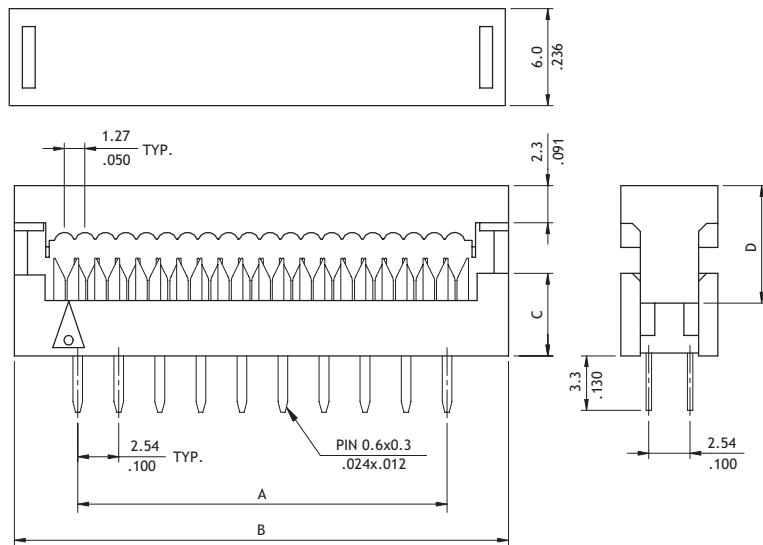
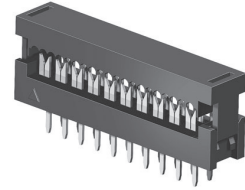

Recommended P.C. Board Layout

Circuits	Dimension			
	A	B	C	D
6	5.08(.200)	12.98(.511)	5.00(.197)	7.23(.284)
8	7.62(.300)	15.52(.611)	5.00(.197)	7.23(.284)
10	10.16(.400)	18.06(.711)	5.00(.197)	7.23(.284)
12	12.97(.500)	20.60(.811)	5.00(.197)	7.23(.284)
14	15.24(.600)	23.14(.911)	5.00(.197)	7.23(.284)
16	17.78(.700)	25.68(1.011)	5.00(.197)	7.23(.284)
18	20.32(.800)	28.22(1.111)	5.00(.197)	7.23(.284)
20	22.86(.900)	30.76(1.211)	5.00(.197)	7.23(.284)
24	27.94(1.100)	35.84(1.411)	5.00(.197)	7.23(.284)
26	30.48(1.200)	38.38(1.511)	5.00(.197)	7.23(.284)
28	33.02(1.300)	40.92(1.611)	5.00(.197)	7.23(.284)
30	35.56(1.400)	43.46(1.711)	5.00(.197)	7.23(.284)
34	40.64(1.600)	48.54(1.911)	5.00(.197)	7.23(.284)
40	48.26(1.900)	56.16(2.211)	5.00(.197)	7.23(.284)
50	60.96(2.400)	68.86(2.711)	5.00(.197)	7.23(.284)
60	73.66(2.900)	81.65(3.215)	4.00(.157)	6.23(.245)
64	78.74(3.100)	86.73(3.415)	4.00(.157)	6.23(.245)

**Ordering Code**

① ② ③ ④ ⑤ ⑥  
**CA23 64 P A 1 00**

- ① Series No.
- ② No. of Circuits: See above table
- ③ Contact Type=P= Plug
- ④ Plating Code:  
 A=Selective Gold flash over Nickel  
 \*Optional plating available but MOQ requested

- ⑤ Color: 1 = Black
- ⑥ Other Options:  
 00 = Standard  
 \*Special options consult manufacturer

Connection Combination of Board to Board Connectors

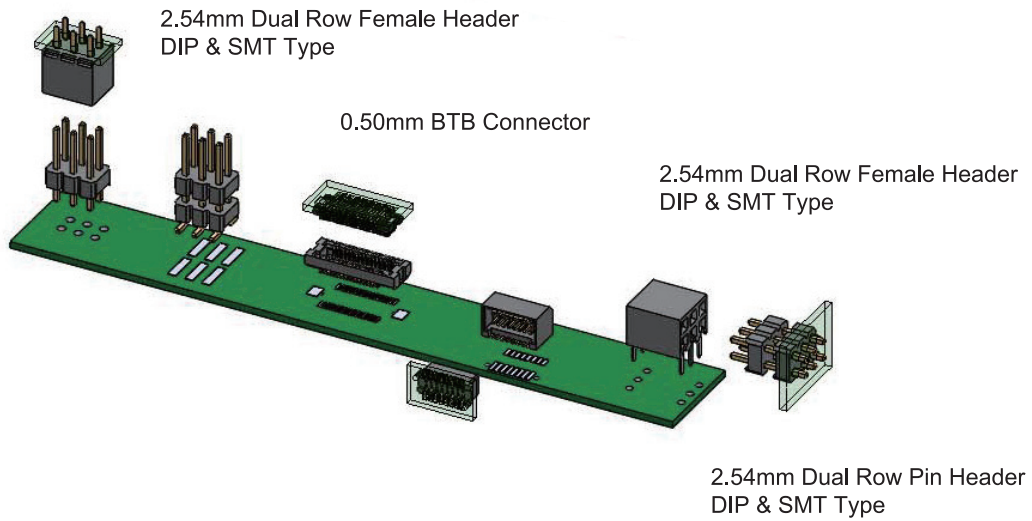
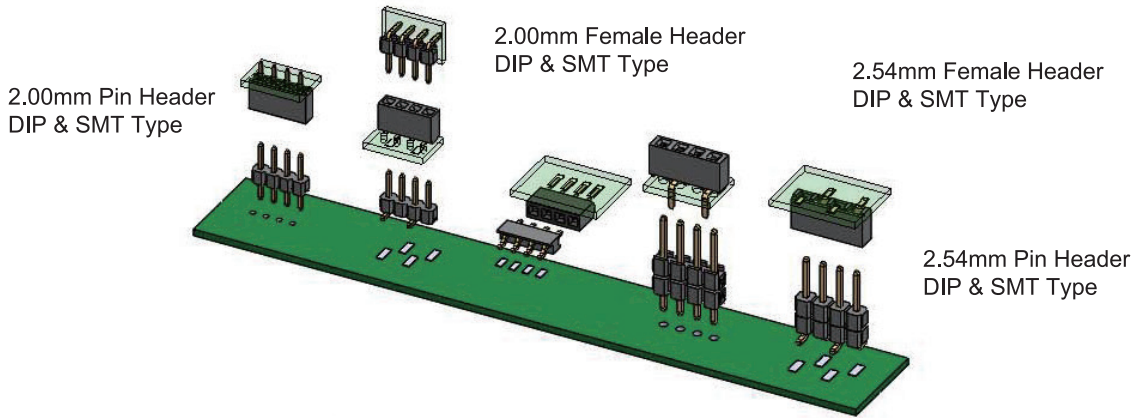

2.54mm Dual Row Pin Header  
DIP & SMT Type

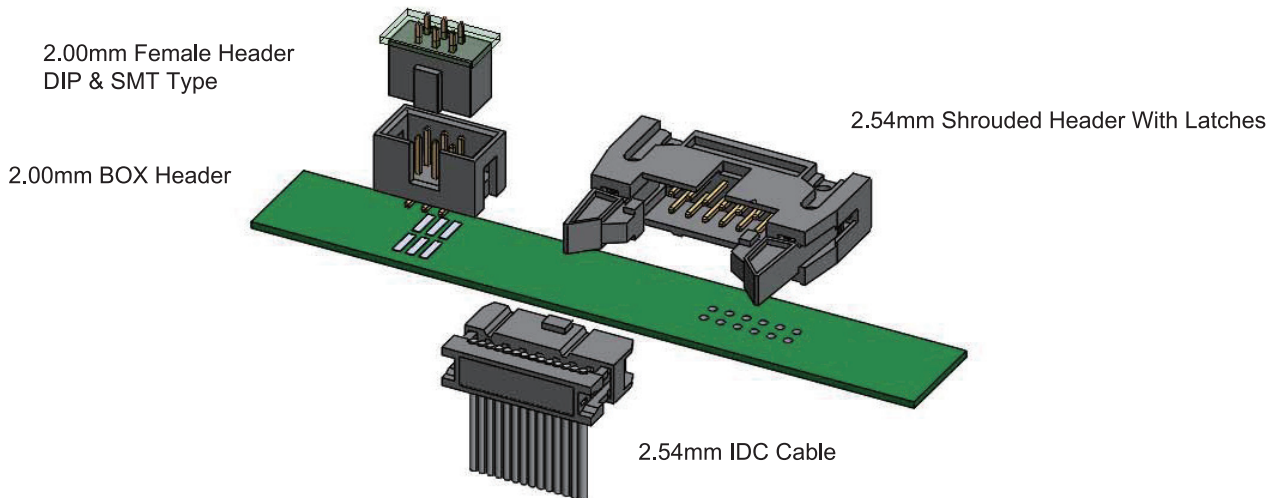

CB

BOARD TO BOARD

# System CB Board To Board Connectors Selection Index

- ⊙ Mating height of pitch 0.5mm and 0.8mm connectors shown as below table;
- ⊙ Mating height of pitch 1.27mm connectors or above, please refer to below table and add the height of male and female insulator body.

⊙ Example (For Pitch 1.27mm or above)

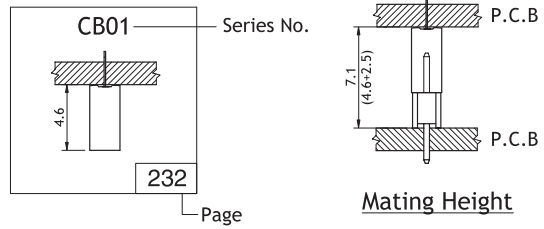

## ⊙ Configuration

0.50mm Center spacing						
Dual Rows Board to Board	CBRC  235	CBRC  235				
	CBRB  233	CBRB  233	CBRB  233	CBRB  233	CBRB  233	CBRB  233
	CBRD  239	CBRD  239	CBRD  239	CBRE  237	CBRE  237	

0.80mm Center spacing		1.0mm Center spacing			
Dual Rows Board to Board	CBC3 & CHC3  241&260	Single Row Female Header	CB03  242	CH16  261	CH07  261











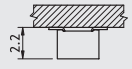

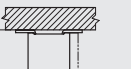

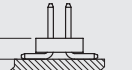

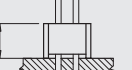
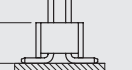



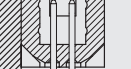

1.27mm Center spacing						
Single Row Female Header	CB01  243	CB01  243				
Single Row Header	CH01  262	CH01  262	CH02  263	CH02  263	CH03  264	CH03  264

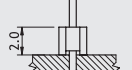
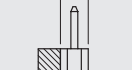
CB

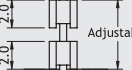
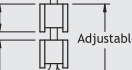
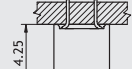
BOARD TO BOARD

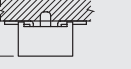
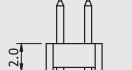
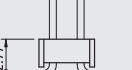
**System CB Board To Board Connectors Selection Index**

1.27mm Center spacing						
Dual Rows Female Header	 <p>2.2</p> <p>244</p>	 <p>4.6</p> <p>245</p>	 <p>4.75</p> <p>245</p>			
Dual Rows Header	 <p>1.0</p> <p>266</p>	 <p>1.55</p> <p>266</p>	 <p>3.4</p> <p>266</p>	 <p>2.5</p> <p>268</p>	 <p>2.97</p> <p>268</p>	 <p>3.4</p> <p>268</p>
	 <p>1.55</p> <p>271</p>	 <p>1.55</p> <p>271</p>	 <p>271</p>	 <p>2.5</p> <p>Adjustable</p> <p>270</p>	 <p>2.5</p> <p>Adjustable</p> <p>270</p>	

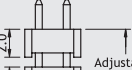
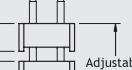
2.0mm Center spacing						
Single Row Female Header	 <p>4.5</p> <p>247</p>					
Single Row Header	 <p>2.0</p> <p>274</p>	 <p>2.0</p> <p>274</p>	 <p>2.77</p> <p>274</p>	 <p>2.0</p> <p>Adjustable</p> <p>276</p>	 <p>2.0</p> <p>Adjustable</p> <p>276</p>	
Dual Rows Female Header	 <p>4.25</p> <p>248</p>	 <p>4.45</p> <p>248</p>	 <p>2.4</p> <p>249</p>			
Dual Rows Header	 <p>2.0</p> <p>277</p>	 <p>2.77</p> <p>277</p>	 <p>4.0</p> <p>277</p>	 <p>4.0</p> <p>279</p>	 <p>4.3</p> <p>279</p>	
	 <p>2.0</p> <p>Adjustable</p> <p>281</p>	 <p>2.0</p> <p>Adjustable</p> <p>281</p>				

CB

BOARD TO BOARD

**System CB Board To Board Connectors Selection Index**

2.54mm Center spacing					
Single Row Female Header	<p>CB33 5.0 250</p>	<p>CB37 6.8 250</p>	<p>CB39 8.6 251</p>	<p>CB39 2.5 251</p>	
Single Row Header	<p>CH31 2.54 283</p>	<p>CH31 2.54 283</p>	<p>CH31 3.81 283</p>	<p>CH34 2.54 Adjustable 282</p>	<p>CH34 2.54 Adjustable 3.81 282</p>
Dual Rows Female Header	<p>CB83 5.0 253</p>	<p>CB85 5.5 253</p>	<p>CB96 11.05 Adjustable 254</p>	<p>CB91 8.6 255</p>	<p>CB91 5.0 255</p>
	<p>CB94 7.1 256</p>	<p>CB94 8.4 256</p>	<p>CB97 5.85 257</p>	<p>CB41 5.25 252</p>	<p>CB86 17.4 258</p>
Dual Rows Header	<p>CH81 2.54 284</p>	<p>CH81 5.0 284</p>	<p>CH81 3.81 284</p>	<p>CH87 9.1 287</p>	<p>CH87 9.1 287</p>
	<p>CH85 2.54 Adjustable 286</p>	<p>CH85 2.54 Adjustable 3.81 286</p>			

CB

BOARD TO BOARD

**CBRH Series 0.4mm(.016") Board to Board Connectors**

- ⊙ Mating Height 0.8 mm
- ⊙ Insulator : High temperature plastic UL 94V-0 , Color Black

**RoHS** Compliant

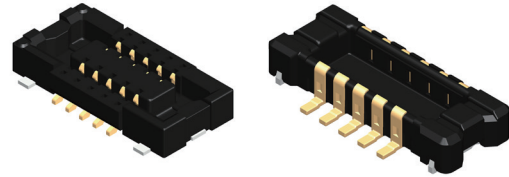

P/N: CBRH\*\*\*POWF00R0-NH

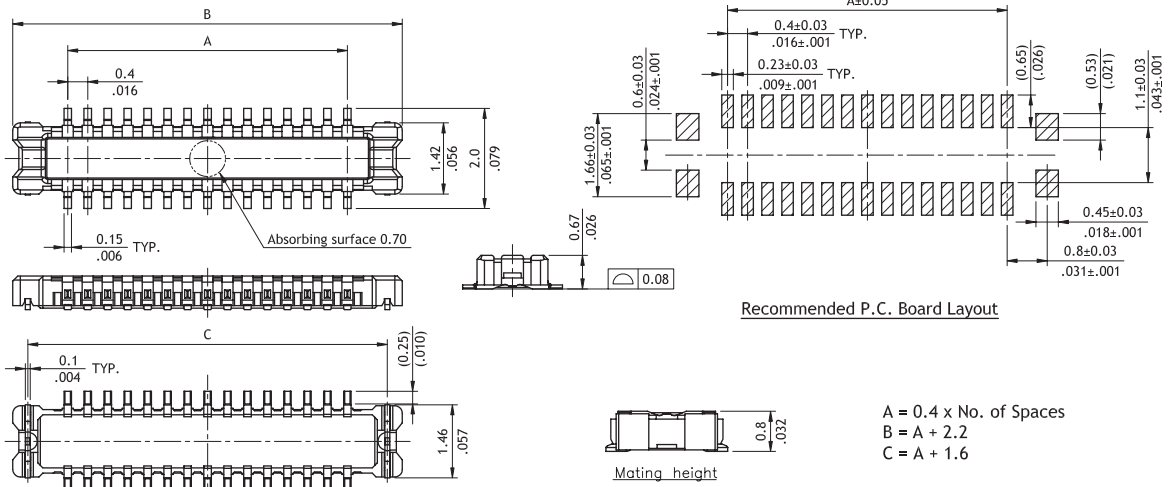

P/N: CBRH\*\*\*SOWF00R0-NH

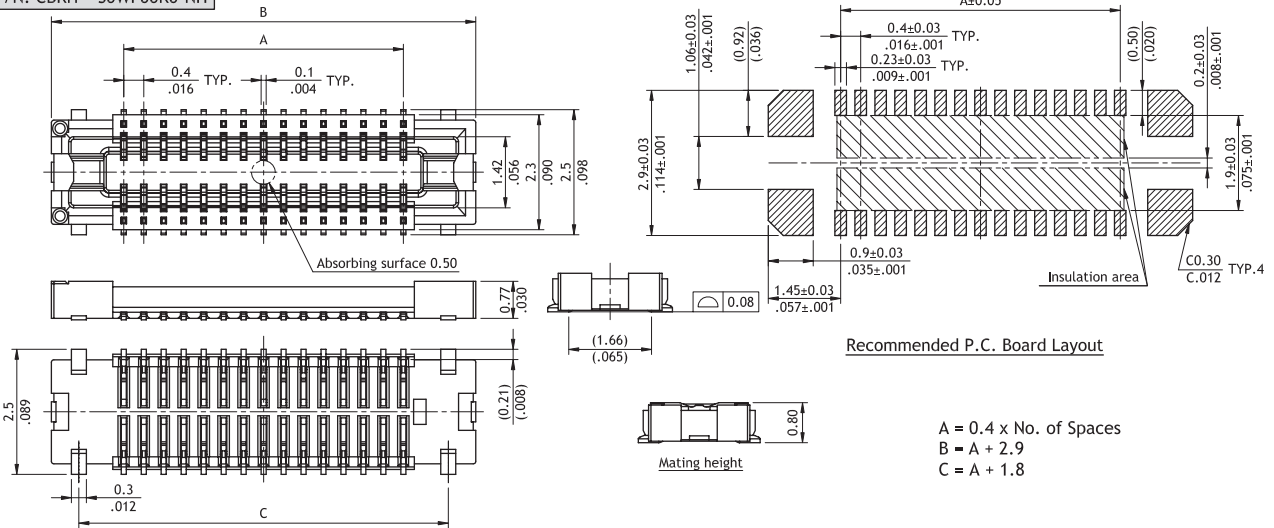

**Ordering Code**

① CBRH ② 10 ③ P0 ④ W ⑤ F00 ⑥ R0 - NH      ① CBRH ② 10 ③ S0 ④ W ⑤ F00 ⑥ R0 - NH

- ① Series No.
- ② No. of Circuits: 10 , 24 , 30 , 40
- ③ P0= Plug
- ④ Plating Code: W = Selective 4μ"Gold flash over Nickel
- ⑤ Fixed Tab Option: F00 = With Fixed Tabs
- ⑥ Packing Options : R0 = Tape & Reel
- ⑦ NH = For Lead Free IR process and Halogen-Free

- ① Series No.
- ② No. of Circuits: 10 , 24 , 30 , 40
- ③ S0= Receptacle
- ④ Plating Code: W = Selective 4μ" Gold flash over Nickel
- ⑤ Fixed Tab Option: F00 = With Fixed Tabs
- ⑥ Packing Options : R0 = Tape & Reel
- ⑦ NH = For Lead Free IR process and Halogen-Free

CB

BOARD TO BOARD

## CBRQ Series 0.4mm(.016") Board to Board Connectors

- ⊙ Mating Height 3.5mm
- ⊙ Insulator : High temperature plastic UL 94V-0 , Color Black

RoHS Compliant

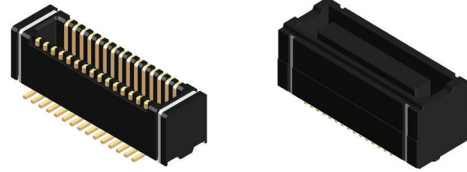

P/N: CBRQ030PA2F00R0-LF

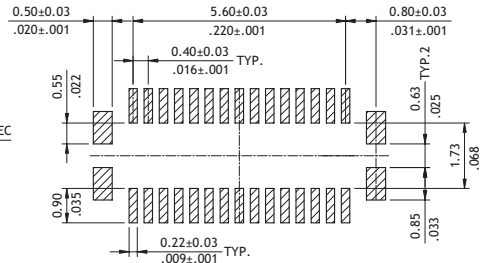
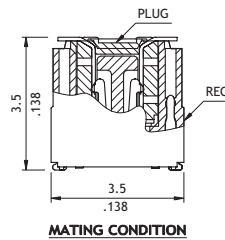
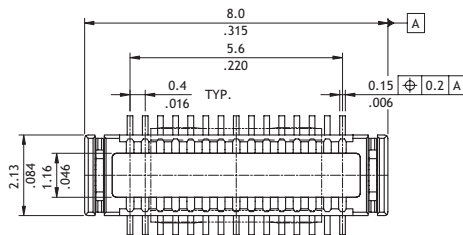

Recommended P.C. Board Layout  
General tolerance ±0.05

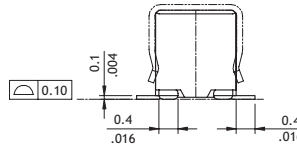
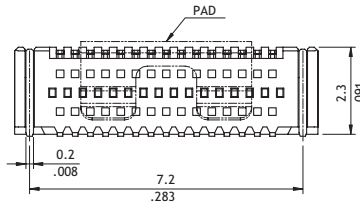

P/N: CBRQ030SA2F00R0-LF

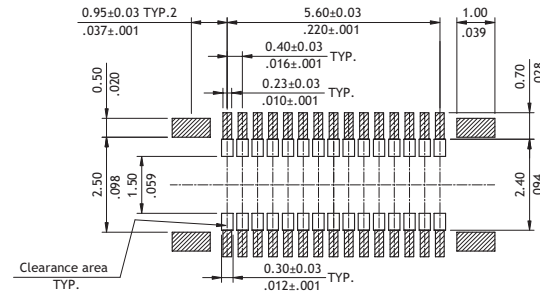
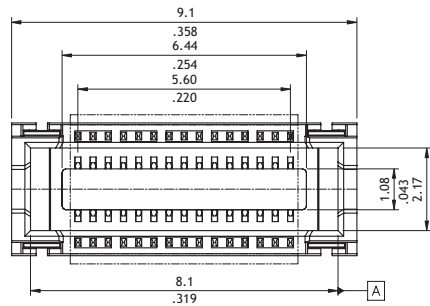

Recommended P.C. Board Layout  
General tolerance ±0.05

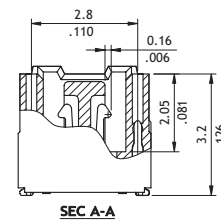
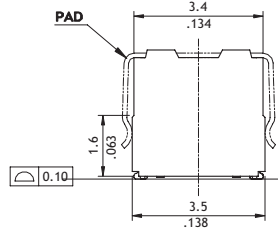
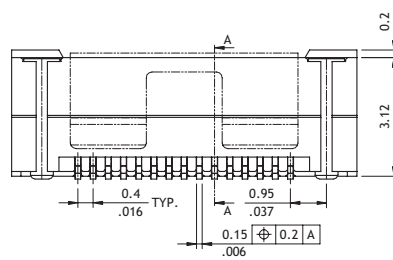

### Ordering Code

① ② ③ ④ ⑤ ⑥ ⑦ ⑧ ⑨      ① ② ③ ④ ⑤ ⑥ ⑦ ⑧ ⑨  
**CBRQ 030 P A 2 F 00 R0 - LF      CBRQ 030 S A 2 F 00 R0 - LF**

- ① Series No.
- ② No. of Circuits: 30
- ③ P= Plug
- ④ Height : A :2.30mm
- ⑤ Plating Code: 2 = Gold flash over Nickel
- ⑥ Fixed Tab Option : F=With Fixed Tabs
- ⑦ Pegs Option : 00 = Without Pegs
- ⑧ Packing Option : R0 =Tape & Reel
- ⑨ LF = For Lead Free IR process

- ① Series No.
- ② No. of Circuits: 30
- ③ S= Receptacle
- ④ Height : A : 3.12mm
- ⑤ Plating Code: 2 = Gold flash over Nickel
- ⑥ Fixed Tab Option : F=With Fixed Tabs
- ⑦ Pegs Option : 00 = Without Pegs
- ⑧ Packing Option : R0 =Tape & Reel
- ⑨ LF = For Lead Free IR process

**CBRB Series 0.50mm(.020") Board To Board Connectors**

- ⊙ Mating Height 2.5, 3.0, 3.5, 4.0, 4.5 ,5.0mm
- ⊙ Insulator: High temperature plastic UL 94V-0, Color Black

RoHS Compliant  

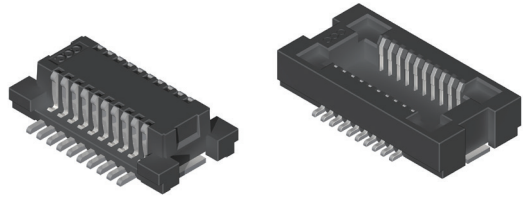

P/N CBRB\*\*\*P\*2FP1R0-NH

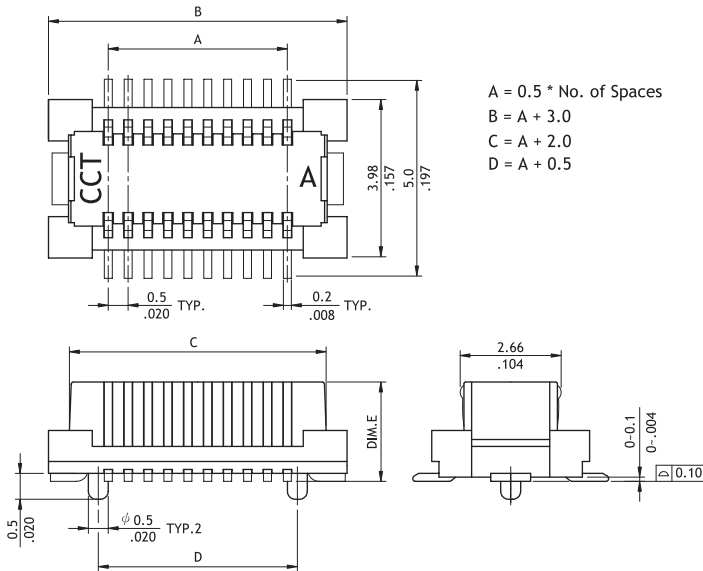

Mating Height	DIM.E
2.5, 3.0, 4.5 mm	2.0
3.5, 4.0, 5.0 mm	3.0

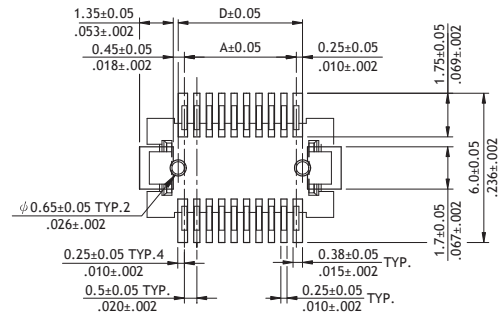

Recommended PCB Layout

P/N CBRB\*\*\*S\*2FP1R0-NH

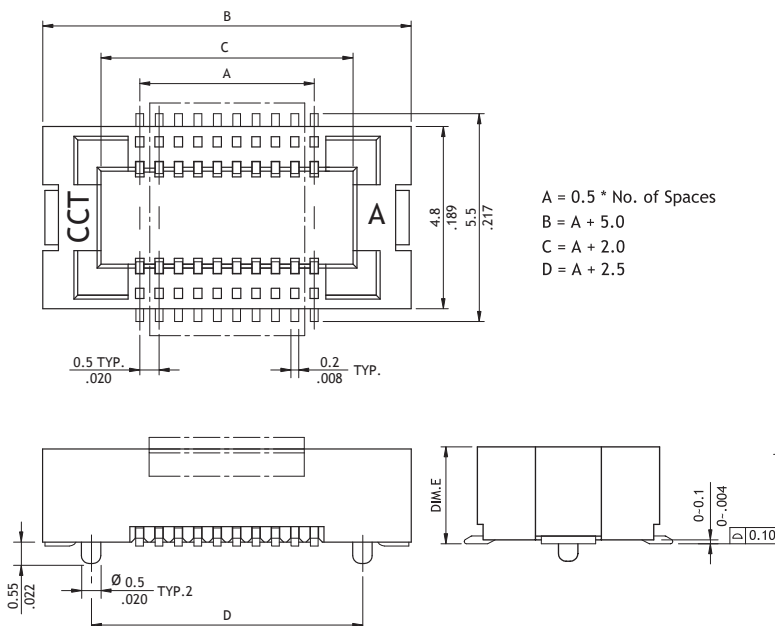

Mating Height	DIM.E
2.5 mm	2.0
3.0 / 3.5 mm	2.5
4.0 mm	3.0
4.5 / 5.0 mm	4.0

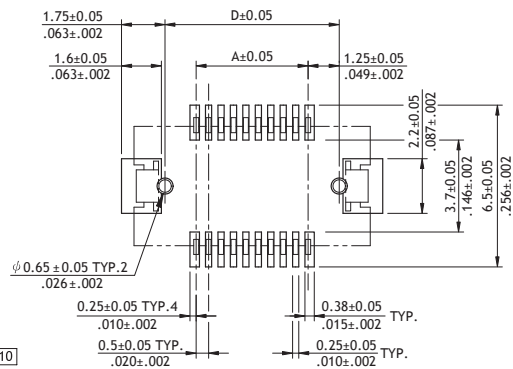

Recommended PCB Layout

**CBRB Series 0.50mm(.020") Board To Board Connectors**

Mating height	Plug	Receptacle
	 P/N: CBRB***PA2FP1R0-NH	 P/N: CBRB***SA2FP1R0-NH
	 P/N: CBRB***PA2FP1R0-NH	 P/N: CBRB***SB2FP1R0-NH
	Circuits: 1 0-60P in  P/N: CBRB***PC2FP1R0-NH	
	Circuits: 1 0-60P in  P/N: CBRB***PC2FP1R0-NH	 P/N: CBRB***SC2FP1R0-NH
	 P/N: CBRB***PA2FP1R0-NH	 P/N: CBRB***SE2FP1R0-NH
	Circuits: 1 0-60 Pin  P/N: CBRB***PC2FP1R0-NH	

CB

**Ordering Code**

① CBRB ② 080 ③ P ④ A ⑤ 2 ⑥ F ⑦ P1 ⑧ R ⑨ 0 - NH ⑩

- ① Series No.
- ② No. of Circuits: 010 ~ 080  
\*Circuits not found above please consult manufacturer
- ③ Connector Type: P = Plug, S = Receptacle
- ④ Height:  
Plug: A: DIM.E = 2.0mm , C: DIM.E = 3.0mm  
Receptacle:  
A: DIM.E = 2.0mm , B: DIM.E = 2.5mm  
C: DIM.E = 3.0mm , E: DIM.E = 4.0mm
- ⑤ Plating Code: 2 = Gold flash over Nickel
- ⑥ Tabs Options: F = With Fixed Tabs  
0 = Without Fixed Tabs
- ⑦ Pegs Options: P1 = With Pegs  
00 = Without Peg
- ⑧ Packing Options: R = Tape & Reel
- ⑨ Other Options: 0 = Standard
- ⑩ NH = For Lead Free IR process and Halogen-Free

BOARD TO BOARD

**CBRC Series 0.50mm(.020") Board To Board Connectors**

- ⊙ Mating Height 1.5mm & 2.0mm
- ⊙ Insulator: High temperature plastic UL 94V-0, Color Nature

**RoHS** Compliant  

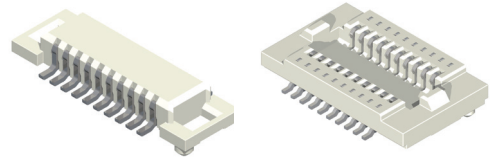

P/N CBRC\*\*\*P02001R0-NH

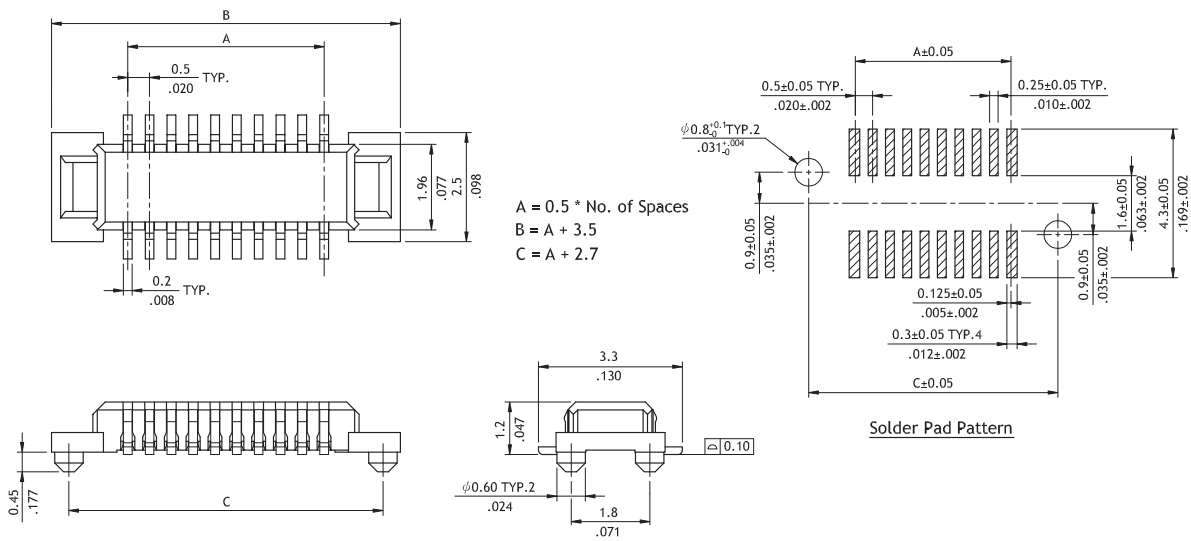

P/N CBRC\*\*\*S\*2001R0-NH

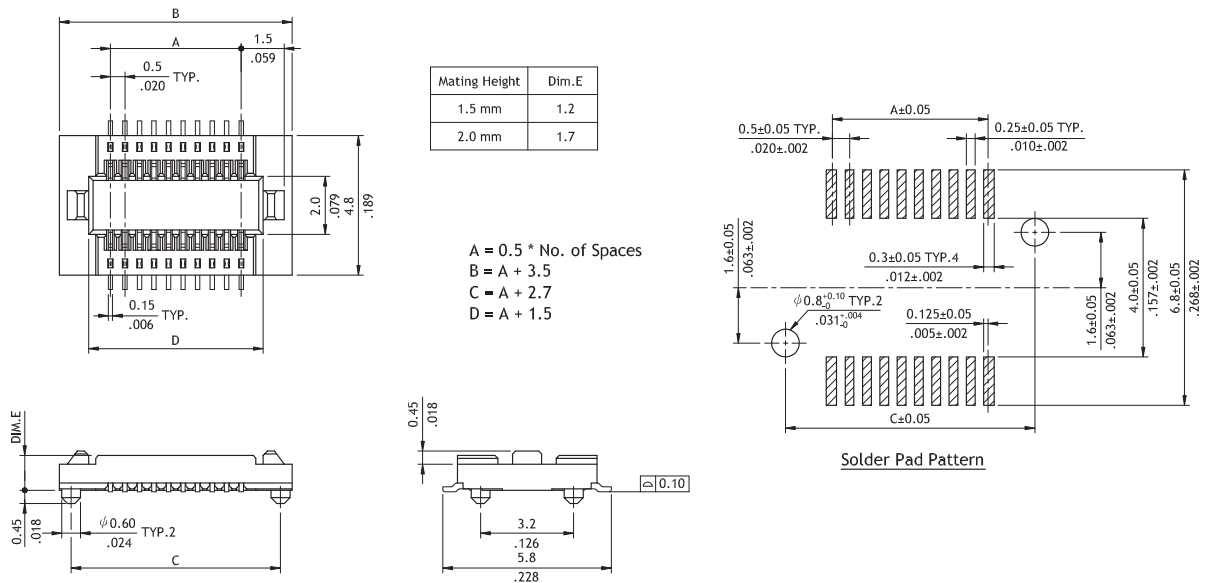

CB

BOARD TO BOARD

**CBRC Series 0.50mm(.020") Board To Board Connectors**

- ⊙ Mating Height 1.5mm & 2.0mm
- ⊙ Insulator: High temperature plastic UL 94V-0, Color Nature

**RoHS** Compliant 

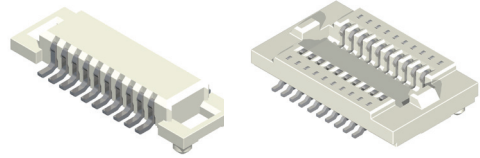

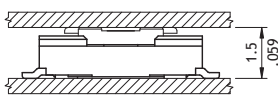
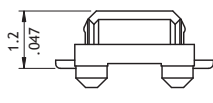
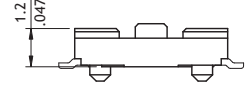
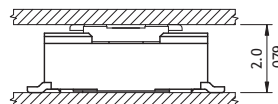
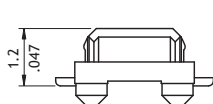
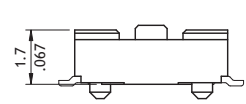
Mating Height	Plug	Receptacle
	<p>Circuits: 10, 16, 20, 22</p>  <p>P/N: <u>CBRC***P0*001R0-NH</u></p>	<p>Circuits: 10, 16, 20, 22</p>  <p>P/N: <u>CBRC***S0200*R0-NH</u></p>
	<p>Circuits: 10, 16, 20, 22</p>  <p>P/N: <u>CBRC***P0*001R0-NH</u></p>	<p>Circuits: 10</p>  <p>P/N: <u>CBRC***SA200*R0-NH</u></p>

**Ordering Code**

①      ②      ③      ④      ⑤      ⑥      ⑦      ⑧  
**CBRC 022 P0 2 001 R 0 - NH**

- ① Series No.
- ② No. of Circuits: 10 ~ 22  
(Available: 10,16,20,22)  
\*Circuits not found above please consult manufacturer
- ③ Connector Type:  
P0 = Plug  
S0 = Receptacle (DIM.E = 1.2mm)  
SA = Receptacle (DIM.E = 1.7mm)
- ④ Plating Code : 2 = Gold flash over Nickel
- ⑤ Pegs Options: 000 = Without Peg  
001 = With Pegs
- ⑥ Packing Options: R = Tape & Reel
- ⑦ Other Options: 0 = Standard
- ⑧ NH = For Lead Free IR process and Halogen-Free

**CBRE Series 0.50mm(.020") Board To Board Connectors**

- ⊙ Mating Height 3.0mm & 3.5mm
- ⊙ Insulator: High temperature plastic UL 94V-0, Color Nature
- ⊙ With metal fixed tabs to secure connector in place

RoHS Compliant

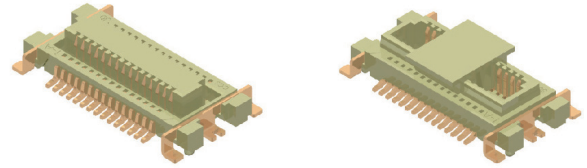

P/N CBRE\*\*\*PA2FP1R0-NH

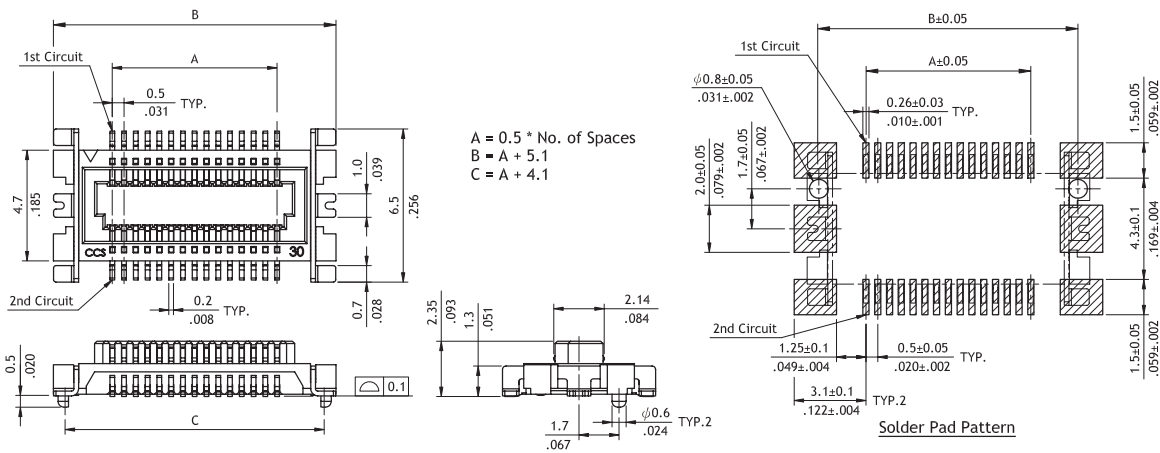

P/N CBRE\*\*\*S\*2FP1R0-NH

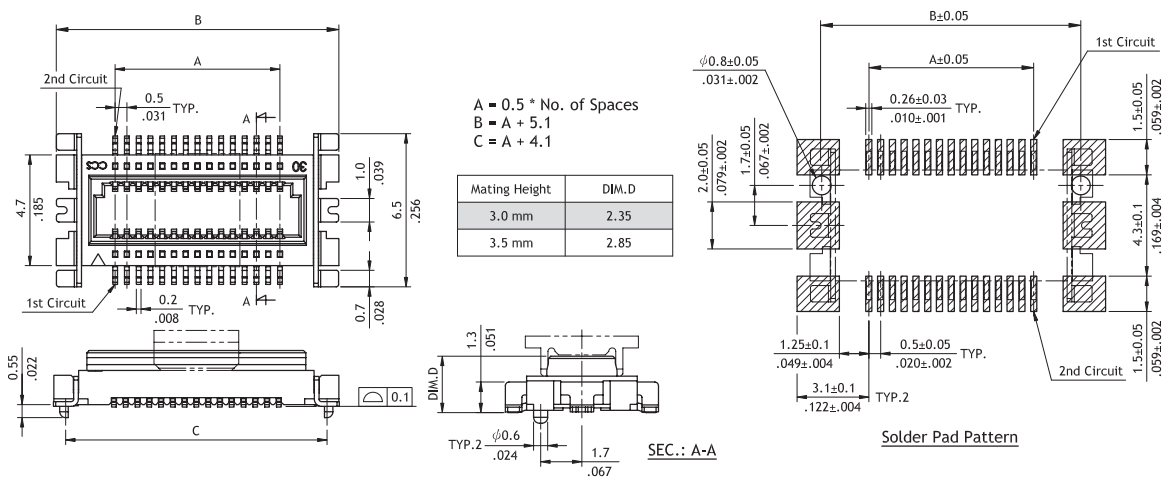

CB

BOARD TO BOARD

**CBRE Series 0.50mm(.020") Board To Board Connectors**

- ⊙ Mating Height 3.0mm & 3.5mm
- ⊙ Insulator: High temperature plastic UL 94V-0, Color Nature
- ⊙ With metal fixed tabs to secure connector in place

RoHS Compliant

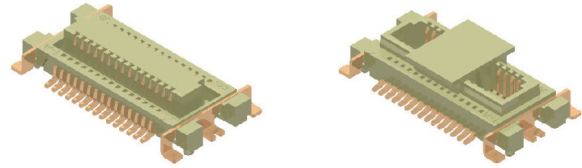

Mating Height	Plug	Receptacle
	<p>Circuits: 10, 20, 30</p> <p>P/N:CBRE***PA2FP1R0-NH</p>	<p>Circuits: 10, 30</p> <p>P/N:CBRE***SA2FP1R0-NH</p>
	<p>Circuits: 10, 20, 30</p> <p>P/N:CBRE***PA2FP1R0-NH</p>	<p>Circuits: 20</p> <p>P/N:CBRE***SB2FP1R0-NH</p>

**Ordering Code**

① ② ③ ④ ⑤ ⑥ ⑦ ⑧ ⑨  
CBRE 030 PA 2 F P1 R 0 -NH

- ① Series No.
- ④ Plating Code: 2 = Gold flash over Nickel
- ② No. of Circuits: 10, 20, 30  
\*Circuits not found above please consult manufacturer
- ⑤ Fixed Tab Options: F = With Fixed Tabs
- ③ Connector Type:  
PA = Plug  
SA = Receptacle (DIM.E = 2.35mm)  
SB = Receptacle (DIM.E = 2.85mm)
- ⑥ Pegs Options: P1 = With Pegs
- ⑦ Packing Options: R = Tape & Reel
- ⑧ Other Options: 0 = Standard
- ⑨ NH = For Lead Free IR process and Halogen-Free

**CBRD Series 0.80mm(.031") Board To Board Connectors**

- ⊙ Mating Height 4.0, 5.0 & 8.0mm
- ⊙ Insulator: High temperature plastic UL 94V-0, Color Nature

**RoHS** Compliant

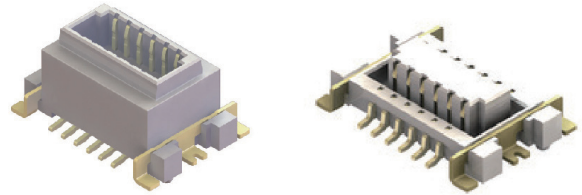

P/N CBRD\*\*\*PA2\*\*\*R0-NH

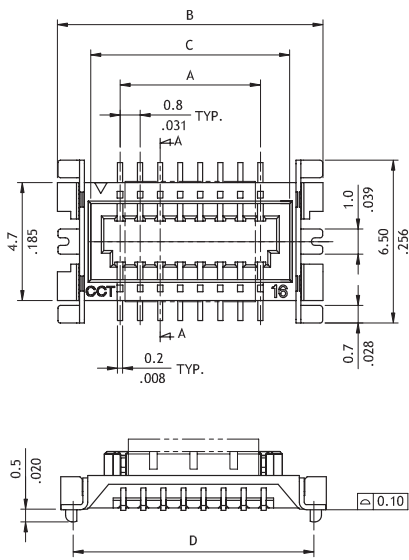

A = 0.8 \* No. of Spaces  
 B = A + 5.0  
 C = A + 2.34  
 D = A + 4.0

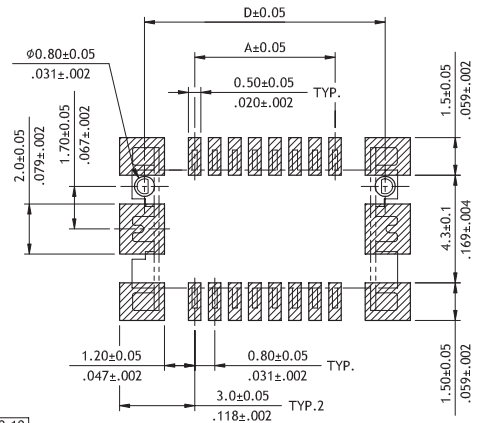
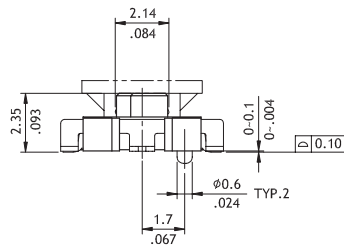

Recommended PCB Layout

P/N CBRD\*\*\*S\*2\*\*\*R0-NH

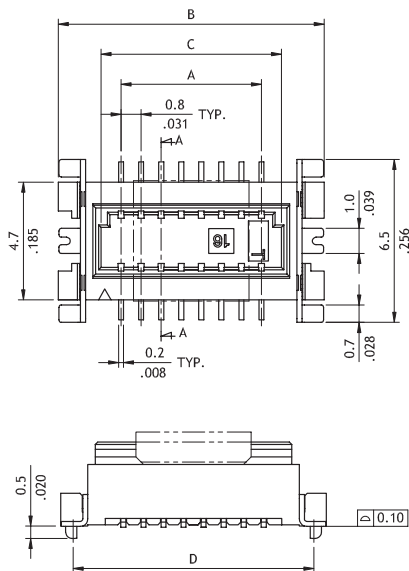

A = 0.8 \* No. of Spaces  
 B = A + 5.0  
 C = A + 1.6  
 D = A + 4.0

Mating Height	DIM.E
4.0 mm	3.4
5.0 mm	4.4
8.0 mm	7.4

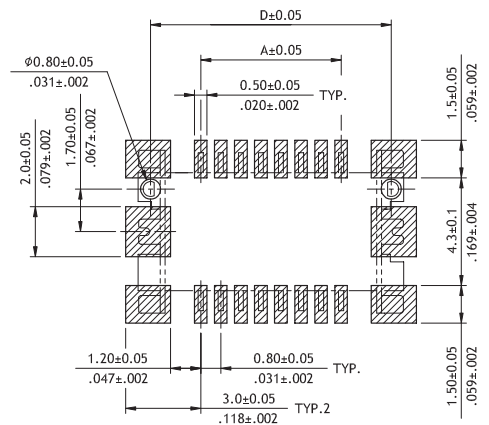
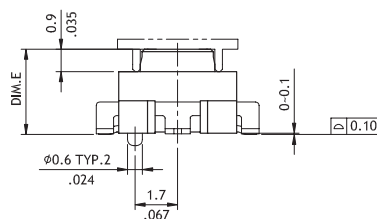

Recommended PCB Layout

CB

BOARD TO BOARD

**CBRD Series 0.80mm(.031") Board To Board Connectors**

© MOQ: 5000pcs but also based on MPQ

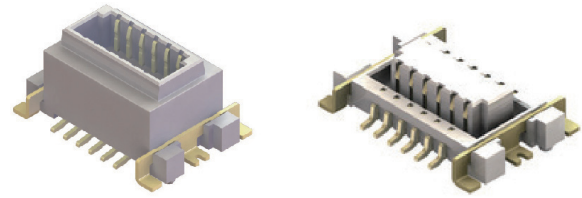

Mating Height	Plug	Receptacle
<p>4.0 .157</p>	<p>2.35 .093</p> <p>P/N:CBRD***PA2FP1R0-NH</p>	<p>3.4 .134</p> <p>P/N:CBRD***SA2FP1R0-NH</p>
<p>5.0 .197</p>	<p>2.35 .093</p> <p>P/N:CBRD***PA2FP1R0-NH</p>	<p>4.4 .173</p> <p>P/N:CBRD***SB2FP1R0-NH</p>
<p>8.0 .315</p>	<p>2.35 .093</p> <p>P/N:CBRD***PA2FP1R0-NH</p>	<p>7.4 .291</p> <p>P/N:CBRD***SE2FP1R0-NH</p>

**Ordering Code**

① ② ③ ④ ⑤ ⑥ ⑦ ⑧ ⑨ ⑩  
**C B R D 0 8 0 S A 2 F P 1 R 0 - N H**

- ① Series No.
- ② No. of Circuits: 010 ~ 080  
(Available: 10,12,14,16,20,24,30,34, 36,40,50,60,80)  
\*Circuits not found above please consult manufacturer
- ③ Connector Type:  
P = Plug  
S = Receptacle

- ④ Height:  
Plug: A: DIM.E = 2.35mm  
Receptacle: A: DIM.E = 3.40mm  
B: DIM.E = 4.40mm  
E: DIM.E = 7.40mm
- ⑤ Plating Code:  
2 = Gold flash over Nickel
- ⑥ Fixed Tab Options:  
0 = Without Fixed Tab  
F = With Fixed Tabs

- ⑦ Pegs Options:  
00 = Without Peg  
P1 = With Pegs
- ⑧ Packing Options:  
R = Tape & Reel
- ⑨ Other Options: 0 = Standard
- ⑩ NH = For Lead Free IR process and Halogen-Free

**CBC3 Series 0.80mm(.031") Dual Row Female Headers**

- ☉ Mate with CHC3 Header
- ☉ Insulator: High temperature plastic UL 94V-0, Color Black

RoHS Compliant

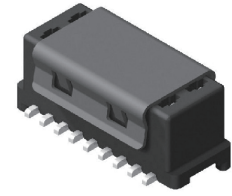

CB

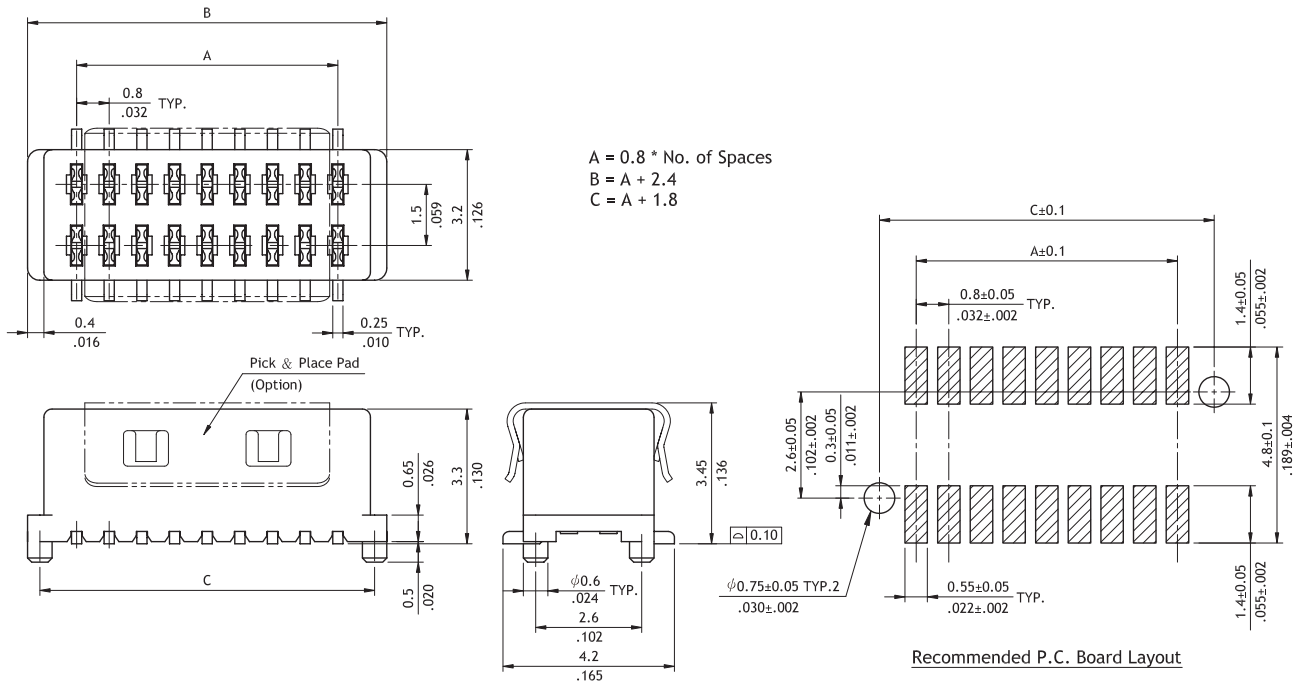

**Ordering Code**

① ② ③ ④ ⑤ ⑥ ⑦  
**CBC3 36 1 M 1 R 0**

- ① Series No.
- ② No. of Circuits: 06 ~ 36
- ③ Plating Code:  
 1 = Tin over Nickel  
 2 = Gold flash over Nickel
- ④ Tail Style: M = SMT Type
- ⑤ Color: 1 = Black
- ⑥ Packing Options:  
 R = Tape & Reel (With pick & place pad)  
 T = Tube
- ⑦ Other Options: 0 = Standard  
 \* Special options consult manufacturer

BOARD TO BOARD

### CB03 Series 1.00mm(.039") SMT Type Single Row Pin Headers

☉ Mate with CH07 series

RoHS Compliant

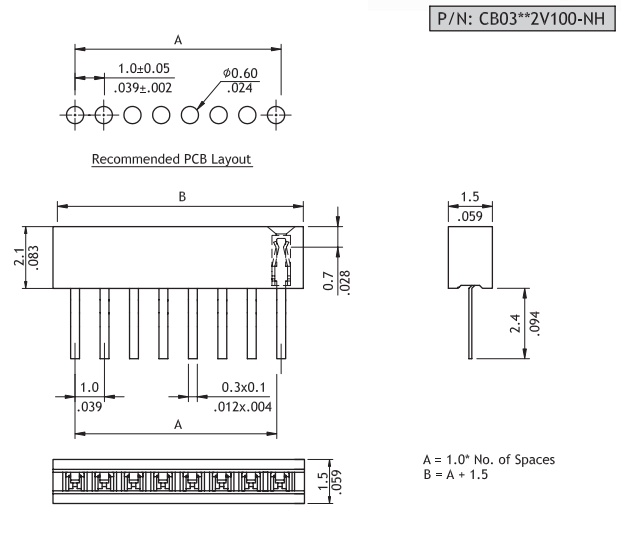
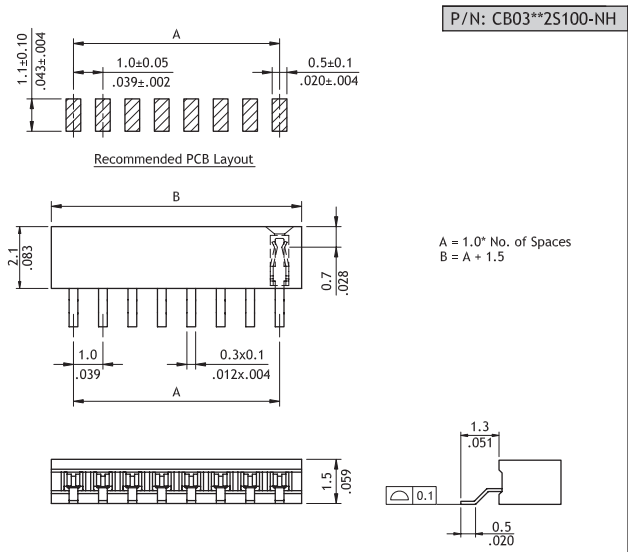
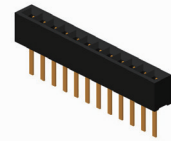

**Ordering Code**

①	②	③	④	⑤	⑥	⑦
CB03	50	2	S	1	00	-NH

① Series No.  
② No. of Circuits: 02 ~ 50  
③ Plating Code: 2 = Gold flash over Nickel  
④ Tail Style: S = SMT Type  
V = Straight DIP Type  
⑤ Color: 1 = Black  
⑥ Other Options: 00 = Standard  
⑦ NH = For Lead Free Soldering process and Halogen-Free

### CB12 Series 1.00mm(.039") Dual Row Female Headers

☉ Mate with CH16 series

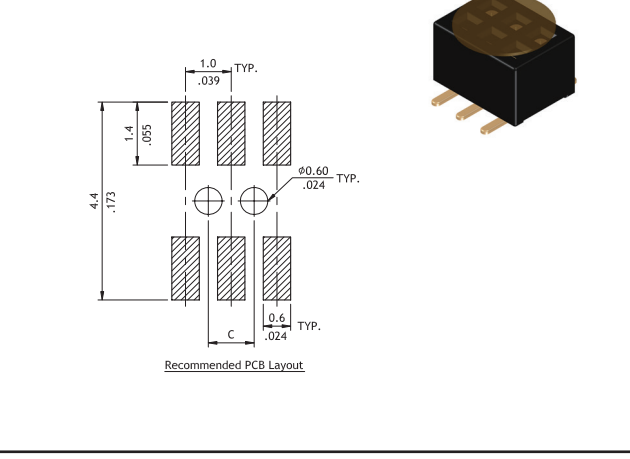
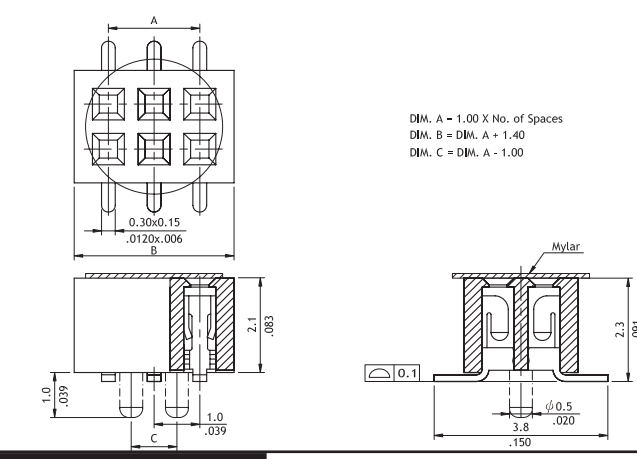
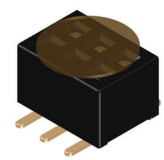

**Ordering Code**

①	②	③	④	⑤	⑥	⑦	⑧
CB12	36	2	M	1	00	-R	P

① Series No.  
② No. of Circuits: 06 ~ 100  
③ Plating Code: 2 = Gold flash over Nickel  
④ Tail Style: M = SMT Type  
⑤ Color: 1 = Black  
⑥ Other Options: 00 = Standard  
⑦ Packing Options: R = Tape & Reel  
⑧ Pegs Options: M = With Mylar & Without Pegs(4P~100P)  
P = With Mylar and Pegs(6P~100P)

CB BOARD TO BOARD

**CB01 Series 1.27mm(.050") Single Row Female Headers**

☉ Mates with CH01, CH02 and CH03 series

RoHS Compliant  

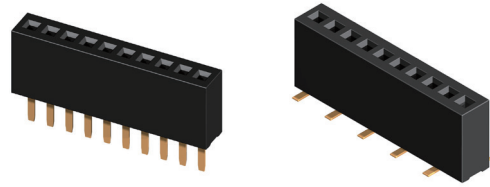

P/N CB01\*\*2D100-NH

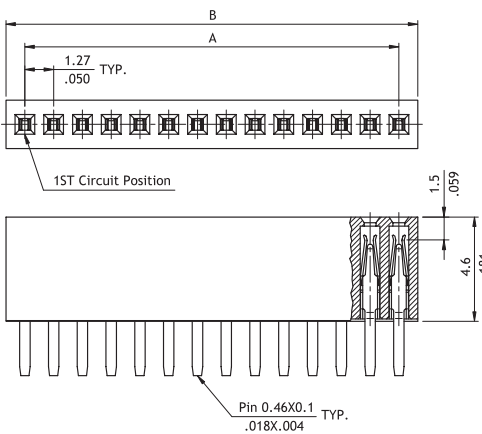

$A = 1.27 * \text{No. of Spaces}$   
 $B = A + 1.67$

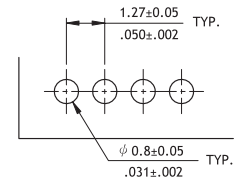
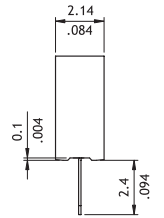

Recommended PCB Layout

P/N CB01\*\*2M100-2\*-NH

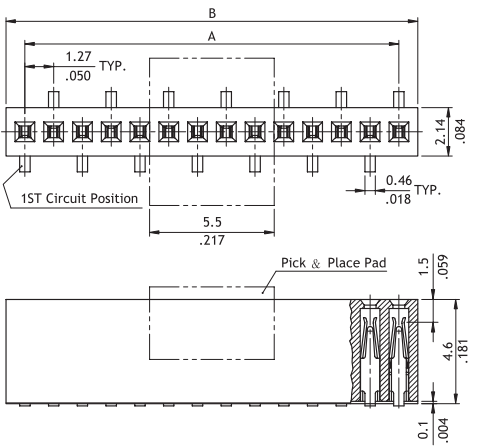

$A = 1.27 * \text{No. of Spaces}$   
 $B = A + 1.67$

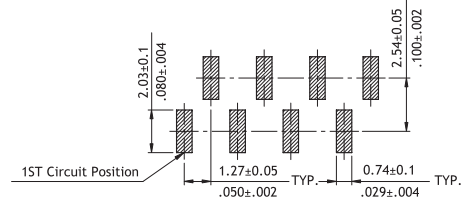
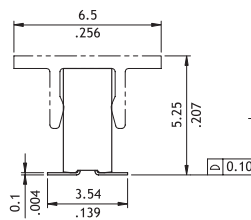

Recommended PCB Layout

**Ordering Code**

① ② ③ ④ ⑤ ⑥ ⑦ ⑧ ⑨  
**CB 0 1 5 0 2 M 1 0 0 - 2 0 - NH**

- ① Series No.
- ② No. of Circuits: 04 ~ 50
- ③ Plating Code: 2 = Gold flash over Nickel
- ④ Tail Style: M = SMT Type  
D = DIP Type
- ⑤ Color: 1 = Black
- ⑥ Other Options: 00 = Standard

- ⑦ Mating Header Pin Size:  
2 = 0.4mm Square Pin
- ⑧ Packing Options:  
0 = Without Pick & Place Pad (Tube)  
P = With Pick & Place Pad (Tape & Reel)  
\*Code 7 and 8 for SMT Type only
- ⑨ NH = For Lead Free Soldering process and Halogen-Free

### CB50 Series 1.27mm(.050") Dual Row Female Headers

- ⊙ Ultra Low profile
- ⊙ Top and bottom entry available
- ⊙ High performance contact design
- ⊙ Mates with CH51, CH52, CH53 and CH57 series

RoHS Compliant

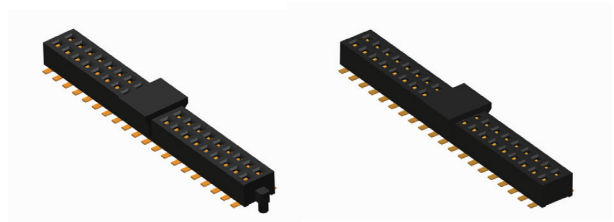

P/N	CB50**20**0-NH	⊙ Without Peg
-----	----------------	---------------

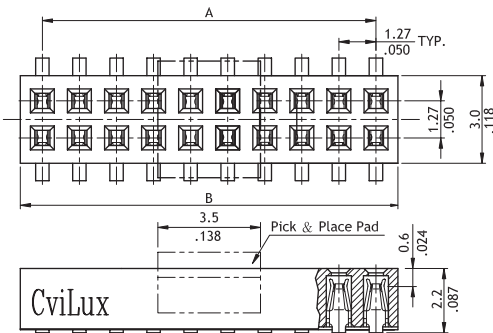

Dim. A = 1.27 X No. of Spaces  
 Dim. B = Dim. A + 1.67  
 Dim. C = Dim. A - 1.27

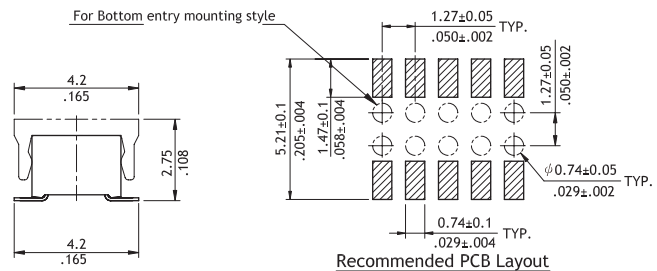

P/N	CB50**2P**0-NH	⊙ Pegs Type 1
-----	----------------	---------------

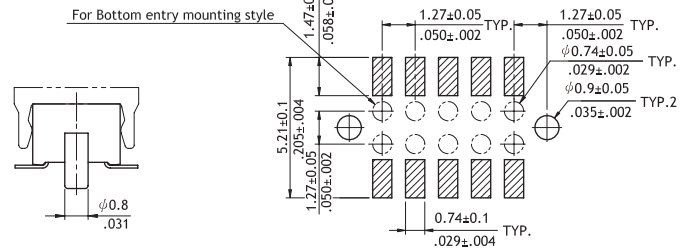
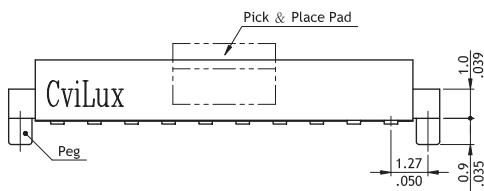

P/N	CB50**2A**0-NH	⊙ Pegs Type 2
-----	----------------	---------------

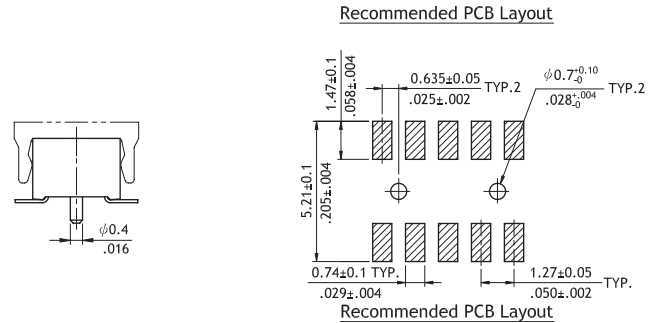
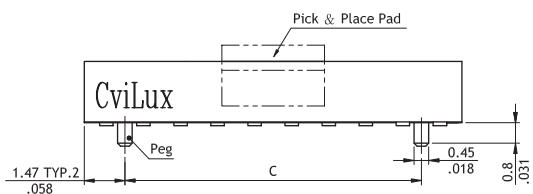

#### Ordering Code

①      ②      ③      ④      ⑤      ⑥      ⑦      ⑧  
**CB 5 0   6 0   2   0   0   R   0   -   NH**

- ① Series No.
- ② No. of Circuits: 06 ~60
- ③ Plating Code: 2 = Gold flash over Nickel
- ④ Pegs Options:  
 0 = Without Peg  
 P = With Pegs Type 1  
 A = With Pegs Type 2

- ⑤ Pegs Options:  
 0 = Without Pick & Place Pad  
 P = With Pick & Place Pad
- ⑥ Packing Options : R = Tape & Reel  
 T = Tube
- ⑦ Other Options: 0 = Standard  
 \*Special options consult manufacturer
- ⑧ NH = For Lead Free IR process and Halogen-Free

**CBC1 Series 1.27mm(.050") Dual Row Female Headers**

- ⊙ Mates with 1.27mm pitch 0.40mm Square pin Header
- ⊙ High performance contact design
- ⊙ Low insertion Force, Anti-flux
- ⊙ With PCB pegs options

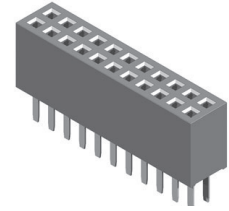

RoHS Compliant  

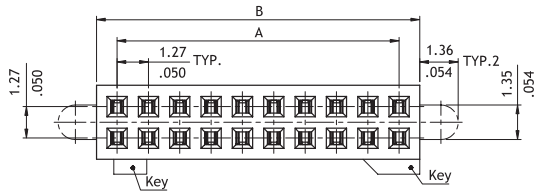

A = 1.27 X No. of Spaces  
 B = A + 1.67  
 C = A + 3.05

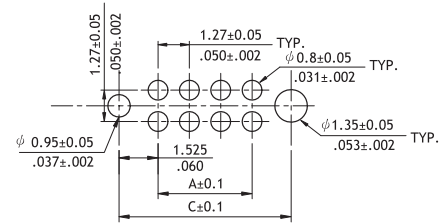
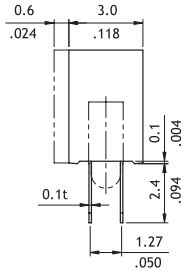
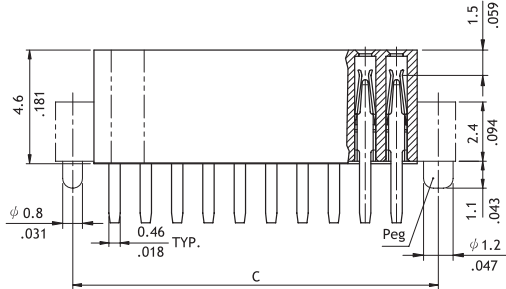

Recommended PCB Layout

**Ordering Code**

① ② ③ ④ ⑤ ⑥ ⑦  
**CBC1 60 2 D 1 00 - NH**

- ① Series No.
- ② No. of Circuits:  
 With keys: 10, 20, 30 ~ 60  
 Without keys: 06 ~ 60
- ③ Plating Code : 2 = Gold flash over Nickel
- ④ Tail Style: D = DIP Type
- ⑤ Color: 1 = Black
- ⑥ Other Options:  
 00 = Without Key and Peg  
 10 = With Keys and Pegs  
 20 = Without Key and With Pegs
- ⑦ NH = For Lead Free soldering process and Halogen-Free

### CBC1 Series 1.27mm(.050") Dual Row Female Headers

- ⊙ Mates with CH51, CH52, CH53, CH57 and CHC2 series
- ⊙ Pick and Place Pad available
- ⊙ High performance contact design
- ⊙ With PCB Pegs options

RoHS Compliant

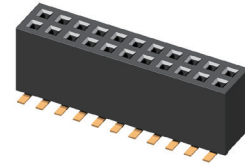

P/N CBC1\*\*2M1\*0-1\*-NH

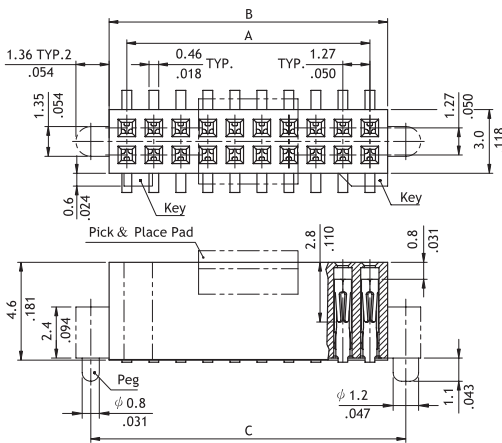

A = 1.27 X No. of Spaces  
 B = A + 1.67  
 C = A + 3.05

P/N CBC1\*\*2M1\*0-2\*-NH

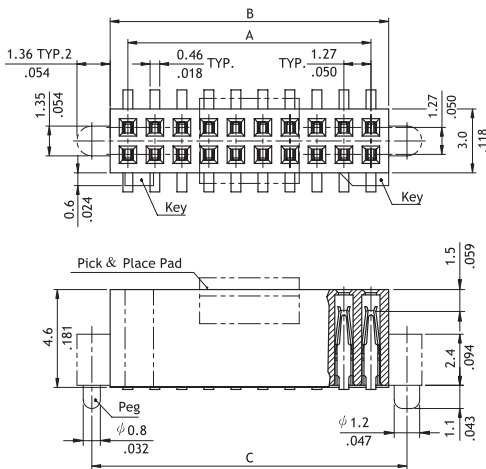

A = 1.27 X No. of Spaces  
 B = A + 1.67  
 C = A + 3.05

Without Key and Peg ; Without Pick & Place Pad	
With Key and Pegs ; Without Pick & Place Pad	
Without Key ; With Pegs ; Without Pick & Place Pad	
Without Key and Peg ; With Pick & Place Pad	
With Key and Pegs ; With Pick & Place Pad	
Without Key ; With Pegs ; With Pick & Place Pad	

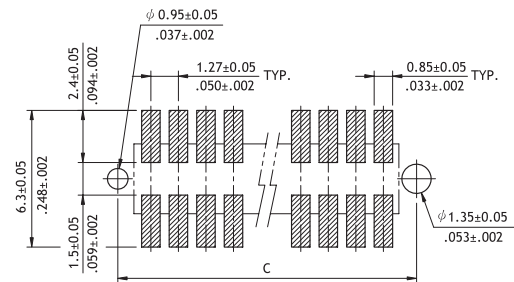

Recommended PCB Layout

#### Ordering Code

① ② ③ ④ ⑤ ⑥ ⑦ ⑧ ⑨ ⑩  
**CBC 1 6 0 2 M 1 0 0 - 2 P - NH**

- ① Series No.
- ② No. of Circuits:  
 With Keys: 10 ~60  
 Without Keys: 06 ~ 60
- ③ Plating Code : 2 = Gold flash over Nickel
- ④ Tail Style: M = SMT Type
- ⑤ Color: 1 = Black
- ⑥ Other Options:  
 0 = Without Key and Peg  
 1 = With Keys and Pegs  
 2 = Without Key and With Pegs
- ⑦ Other Options:  
 0 = Standard
- ⑧ Mating Header Pin Size:  
 1 = 0.46mm Round Pin  
 2 = 0.40mm Square Pin
- ⑨ Packing Options:  
 0 = Without Pick & Place Pad (Tube)  
 P = With Picks & Place Pad ( Tape & Reel)
- ⑩ NH = For Lead Free IR process and Halogen-Free

**CB22 Series 2.00mm(.079") Single Row Female Headers**

☉ Mates with CH11 and CH21 series

**RoHS** Compliant

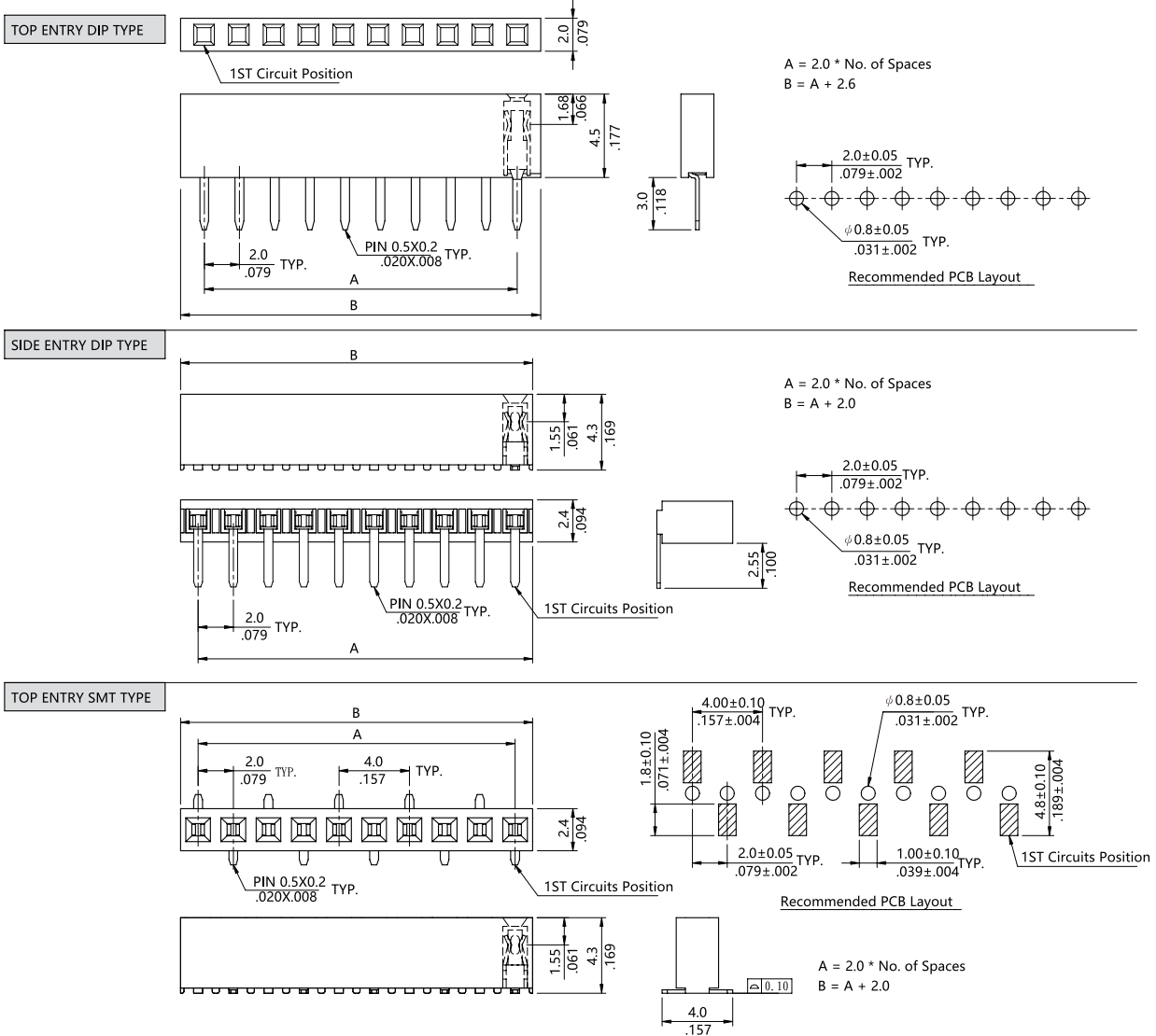
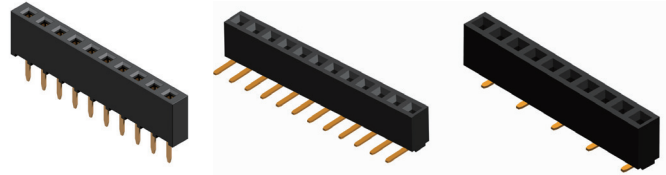

**Ordering Code**

①	②	③	④	⑤	⑥
CB22	40	2	V	1	00

- ① Series No.
- ② No. of Circuits:  
DIP : 02 ~ 40 SMT: 03 ~ 40
- ③ Plating Code : 2 = Gold flash over Nickel
- ④ Tail Style:  
V = Straight DIP  
H= Right angle DIP  
M= Straight SMT
- ⑤ Color: 1 = Black
- ⑥ Other Options : 00 = Standard  
\*Special options consult manufacturer

## CB74 Series 2.00mm(.079") Dual Row Female Headers

☉ Mates with CH71, CH72 and CH75 series

RoHS Compliant

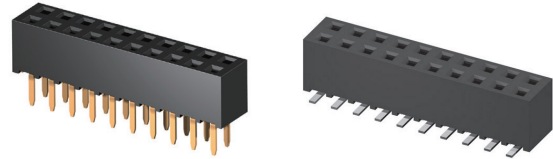

P/N CB74\*\*2V100-NH

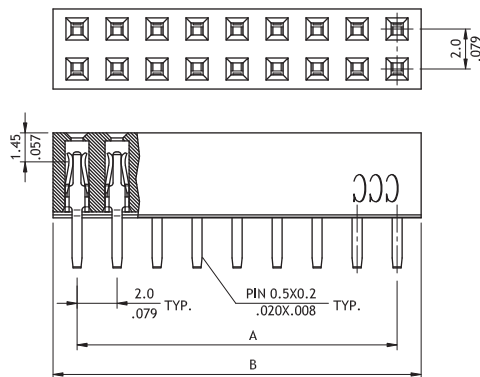

A = 2.0 \* No. of Spaces  
B = A + 2.4

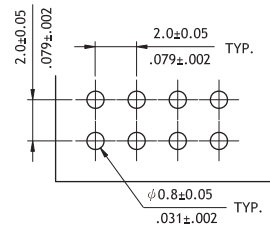

Recommended PCB Layout

P/N CB74\*\*2M100-NH

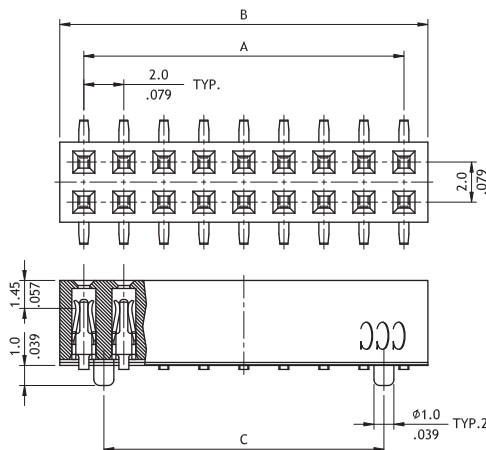

A = 2.0 \* No. of Spaces  
B = A + 2.4  
C = A - 2.0

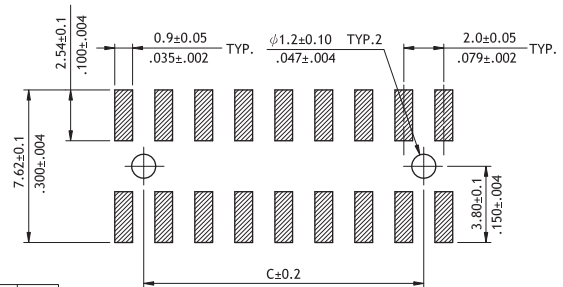

Recommended PCB Layout

### Ordering Code

①    ②    ③    ④    ⑤    ⑥    ⑦  
**CB74 80 2 M 1 00 - NH**

- ① Series No.
- ② No. of Circuits: 04 ~ 80
- ③ Plating Code : 2 = Gold flash over Nickel
- ④ Tail Style:  
V = Top Entry DIP Type  
M = Top Entry SMT Type

- ⑤ Color: 1 = Black
- ⑥ Other Options:  
00 = Standard  
\*Special options consult manufacturer
- ⑦ NH = For Lead Free soldering process and Halogen-Free

**CB76 Series 2.00mm(.079") Dual Row Female Headers**

☉ Mate with CH71, CH72 and CH75 series

RoHS Compliant  

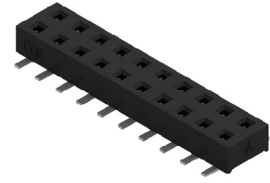

CB

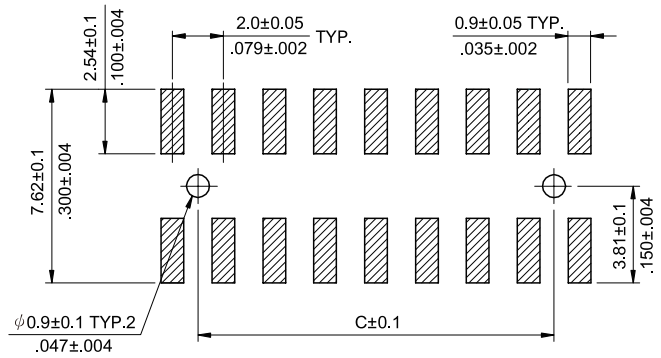
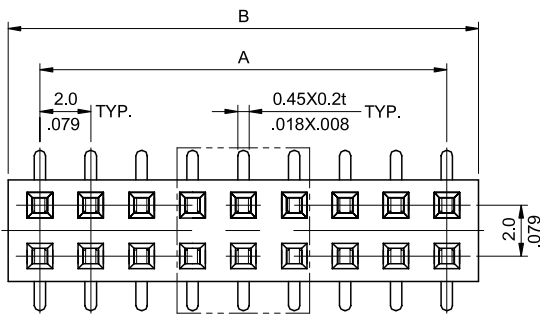

Recommended P.C. Board Layout

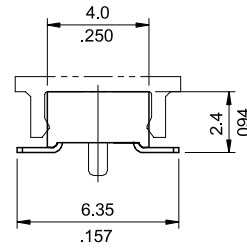
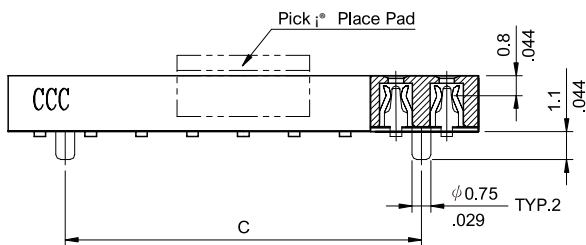

A = 2.0 \* No. of Spaces  
 B = A + 2.5  
 C = A - 2.0

**Ordering Code**

①    ②    ③    ④    ⑤    ⑥    ⑦    ⑧  
**CB76 40 2 M 1 0 0 - NH**

- ① Series No.
- ② No. of Circuits: 04 ~ 40
- ③ Plating Code : 2 = Gold flash over Nickel
- ④ Tail Style: M = SMT Type
- ⑤ Color: 1 = Black

- ⑥ Pegs Options:  
 0 = With Pegs  
 1 = Without Peg
- ⑦ Packing Options:  
 0 = Tube packing  
 R = Tape & Reel (With Pick & Place Pad)
- ⑧ NH = For Lead Free IR process and Halogen-Free

BOARD TO BOARD

### CB33 Series 2.54mm(.100") Single Row Dual Entry Female Header

☉ Mates with CH31 and CH34 series

RoHS Compliant

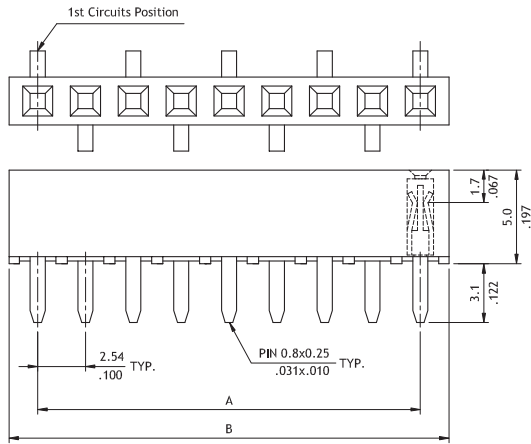

$A = 2.54 * \text{No. of Spaces}$   
 $B = A + 3.14$

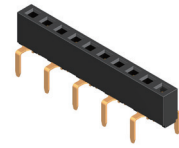
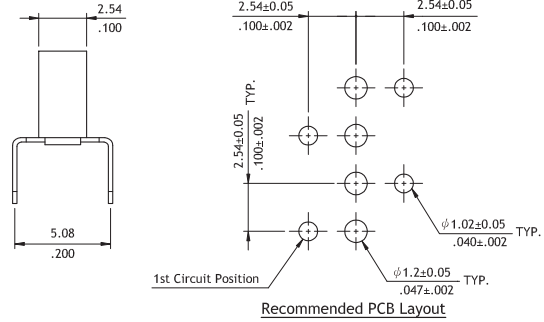

#### Ordering Code

①	②	③	④	⑤	⑥
CB33	40	2	R	1	00

- ① Series No.
- ② No. of Circuits: 02 ~ 40
- ③ Plating Code : 2 = Gold flash over Nickel
- ④ Tail Style: R = Dual Entries

- ⑤ Color: 1 = Black
- ⑥ Other Options: 00 = Standard
- \*Special options consult manufacturer

### CB37 Series 2.54mm(.100") Single Row Female Headers

☉ Mates with CH31 and CH34 series

RoHS Compliant

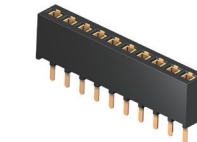
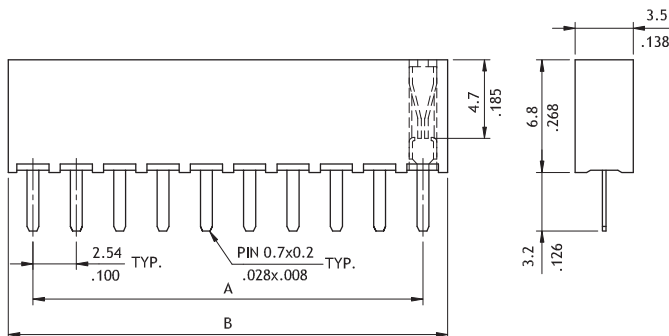
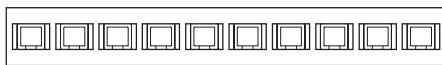

$A = 2.54 * \text{No. of Spaces}$   
 $B = A + 2.5$

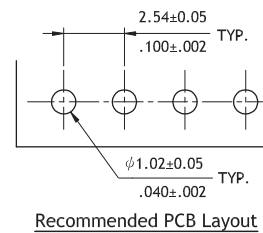

#### Ordering Code

①	②	③	④	⑤	⑥
CB37	40	A	V	1	00

- ① Series No.
- ② No. of Circuits: 02 ~ 40
- ③ Plating Code: A = Selective Gold flash over Nickel
- ④ Tail Style: V = Vertical

- ⑤ Color: 1 = Black
- ⑥ Other Options: 00 = Standard
- \* Special options consult manufacturer

**CB39 Series 2.54mm(.100") Single Row Female Headers**

© Mates with CH31, CH34 series

**RoHS** Compliant

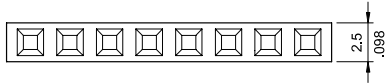
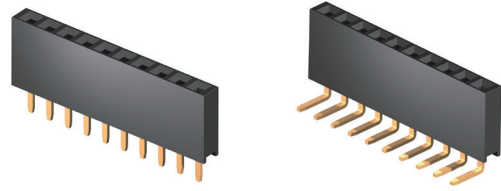

A = 2.54 \* No. of Spaces  
B = A + 3.04

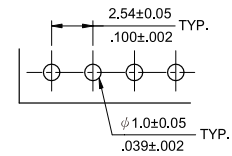
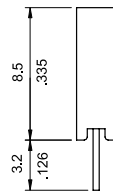
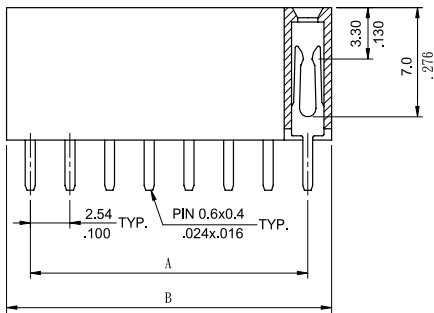

Recommended P.C. Board Layout

CB

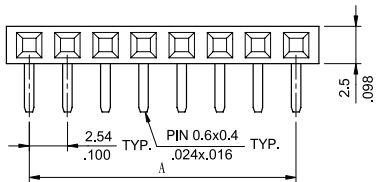

A = 2.54 \* No. of Spaces  
B = A + 3.04

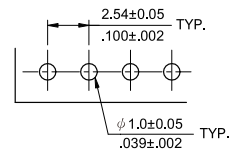
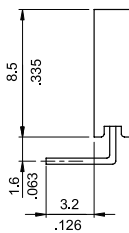
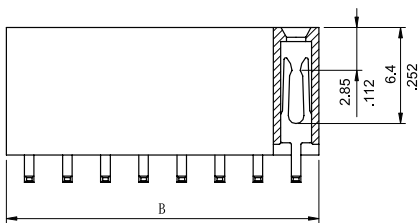

Recommended P.C. Board Layout

**Ordering Code**

①	②	③	④	⑤	⑥
CB39	40	2	V	1	00

- ① Series No.
- ② No. of Circuits: 02 ~ 40
- ③ Plating Code : 2 = Gold flash over Nickel
- ④ Tail Style:  
V = Vertical  
H = Right Angle

- ⑤ Color: 1 = Black
- ⑥ Other Options:  
00 = Standard  
\*Special options consult manufacturer

BOARD TO BOARD

**CB41 Series 2.54mm(.100") Dual Row Female Headers**

CB41 Mates with CH81, CH84, CH85 and CH88 series

**RoHS** Compliant

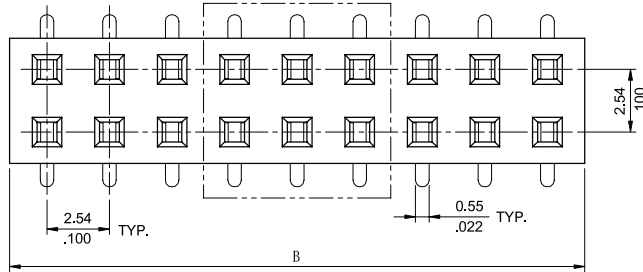
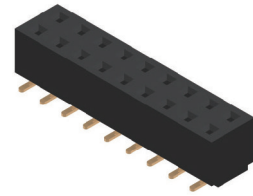

Dim. A = 2.54 X No. of Spaces  
 Dim. B = Dim. A + 3.04  
 Dim. C = Dim. A - 2.54

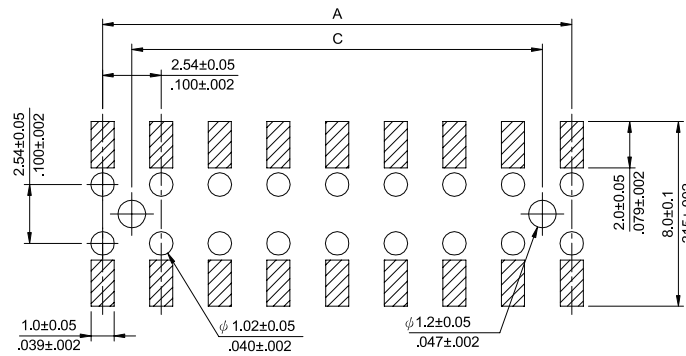
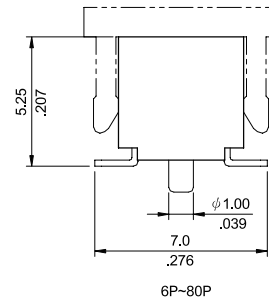
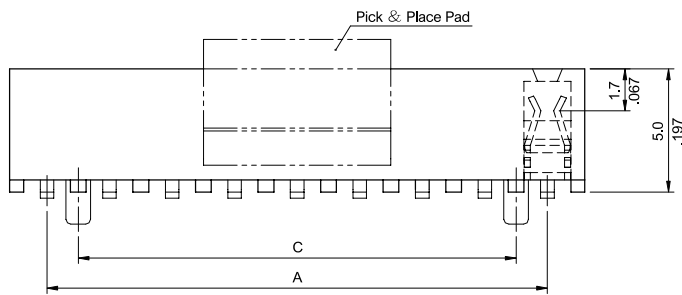
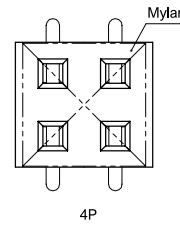

Recommended P.C. Board Layout

**Ordering Code**

①	②	③	④	⑤	⑥
CB41	80	2	M	1	R0

- ① Series No.
- ② No. of Circuits: 04 ~ 80
- ③ Plating Code : 2 = Gold flash over Nickel
- ④ Tail Style: M = SMT Type
- ⑤ Color: 1 = Black

- ⑥ Packing Options:  
 P0 = With Pad & Without Pegs (Tube Packing)  
 PP = With Pad & With Pegs (Tube Packing)  
 R0 = With Pad & Without Peg (Reel Packing)  
 RP = With Pad & With Pegs (Reel Packing)  
 \*Special options consult manufacturer

**CB83 Series 2.54mm(.100") Dual Row Female Headers**

☉ Mates with CH81, CH84 and CH85 series

**RoHS** Compliant

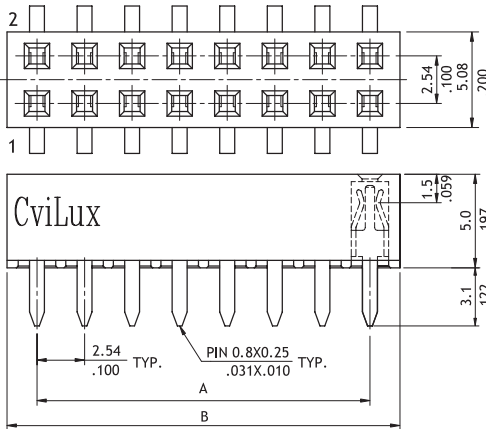
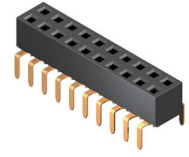

$A = 2.54 * \text{No. of Spaces}$   
 $B = A + 3.2$

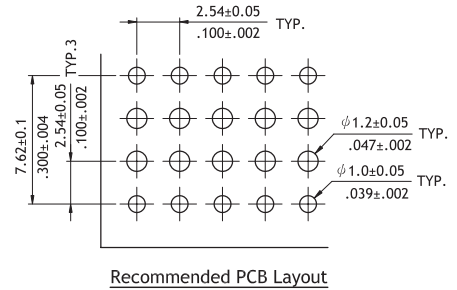
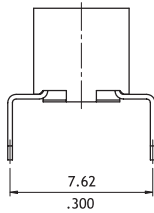

CB

**Ordering Code**

①	②	③	④	⑤	⑥
<b>CB83</b>	<b>40</b>	<b>2</b>	<b>R</b>	<b>1</b>	<b>00</b>

- ① Series No.
- ② No. of Circuits: 04 ~ 40
- ③ Plating Code : 2 = Gold flash over Nickel
- ④ Tail Style: R = Dual Entries
- ⑤ Color: 1 = Black
- ⑥ Other Options:  
00 = Standard  
\*Special options consult manufacturer

**CB85 Series 2.54mm(.100") Dual Row Female Headers**

☉ Mates with CH81, CH84 and CH85 series

**RoHS** Compliant

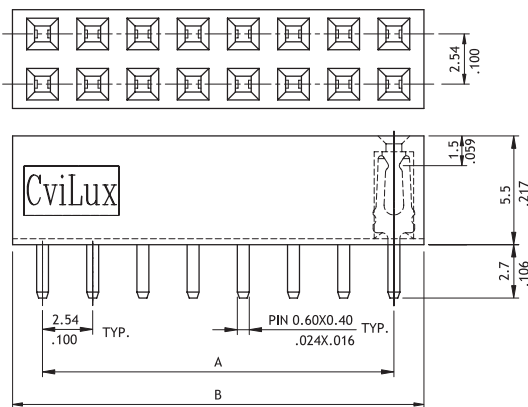
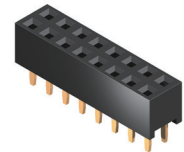

$A = 2.54 * \text{No. of Spaces}$   
 $B = A + 3.0$

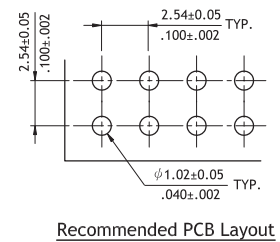
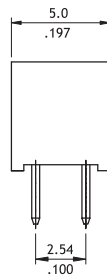

**Ordering Code**

①	②	③	④	⑤	⑥
<b>CB85</b>	<b>40</b>	<b>2</b>	<b>V</b>	<b>1</b>	<b>00</b>

- ① Series No.
- ② No. of Circuits: 04 ~ 40
- ③ Plating Code: 2 = Gold flash over Nickel
- ④ Tail Style: V = Vertical
- ⑤ Color: 1 = Black
- ⑥ Other Options:  
00 = Standard  
\* Special options consult manufacturer

BOARD TO BOARD

**CB96 Series 2.54mm(.100") Dual Row Elevated Female Headers**

© Mates with CH81, CH84 and CH85 series

**RoHS** Compliant

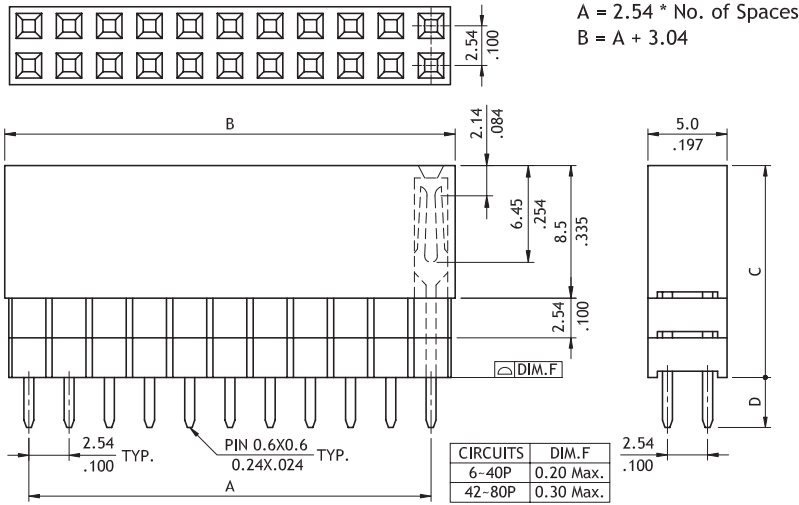
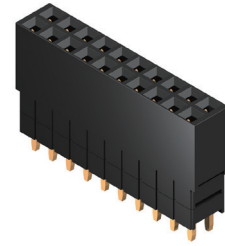

Option Codes	Dimension	
	C	D
00	11.05(.435)	2.3(.091)
1Y	11.05(.435)	7.3(.287)
2Y	13.59(.535)	4.8(.189)
3Y	16.13(.635)	2.3(.091)
1Z	11.05(.435)	12.2(.480)
2Z	13.59(.535)	9.6(.378)
3Z	16.13(.635)	7.1(.280)
4Z	18.67(.735)	4.6(.181)
2W	13.59(.535)	3.4(.134)
2V	13.58(.535)	3.0(.118)

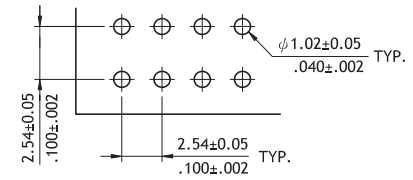

Recommended P.C. Board Layout

**Ordering Code**

①      ②      ③      ④      ⑤      ⑥  
**CB96 80 2 V 1 00**

- ① Series No.
- ② No. of Circuits: 06 ~ 80
- ③ Plating Code: 2 = Gold flash over Nickel
- ④ Tail Style: V = Vertical

- ⑤ Color: 1 = Black
- ⑥ Other Options:  
see option code table  
\*Special options consult manufacturer

**CB91 Series 2.54mm(.100") Dual Row Female Headers**

© Mates with CH81, CH84 and CH85 series

RoHS Compliant

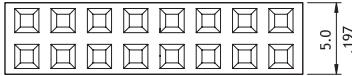
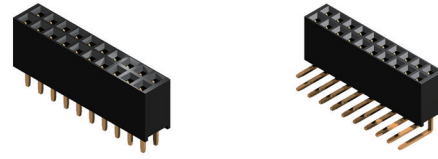

A = 2.54 \* No. of Spaces  
B = A + 3.04

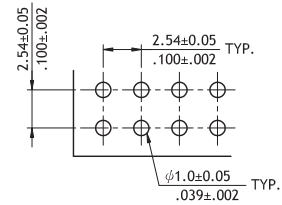
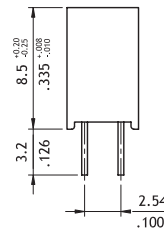
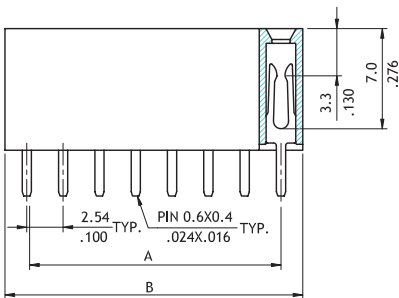

Recommended P.C. Board Layout

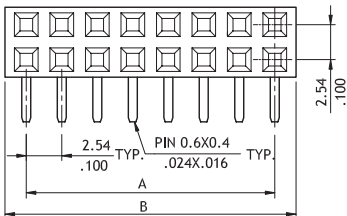

A = 2.54 \* No. of Spaces  
B = A + 3.04

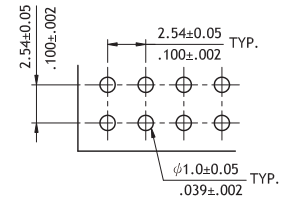
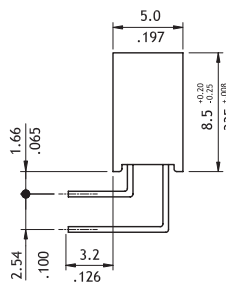
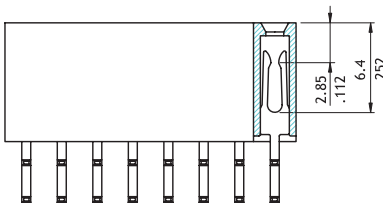

Recommended P.C. Board Layout

**Ordering Code**

①	②	③	④	⑤	⑥
CB91	80	2	V	1	00

- ① Series No.
- ② No. of Circuits: 04 ~50, 60, 64, 66, 80
- ③ Plating Code : 2 = Gold flash over Nickel
- ④ Tail Style: V = Vertical  
H = Right Angle

- ⑤ Color: 1 = Black
- ⑥ Other Options:  
00 = Standard  
\*Special options consult manufacturer

### CB94 Series 2.54mm(.100") Dual Row Female Headers

© Mates with CH81, CH84, CH85, CH87 and CH88 series

RoHS Compliant

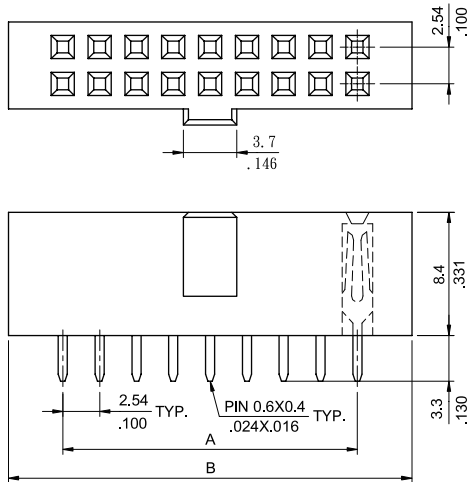
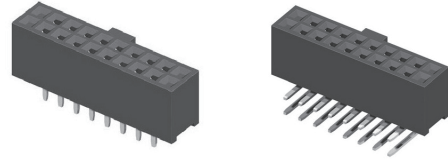

$$A = 2.54 * \text{No. of Spaces}$$

$$B = A + 7.34$$

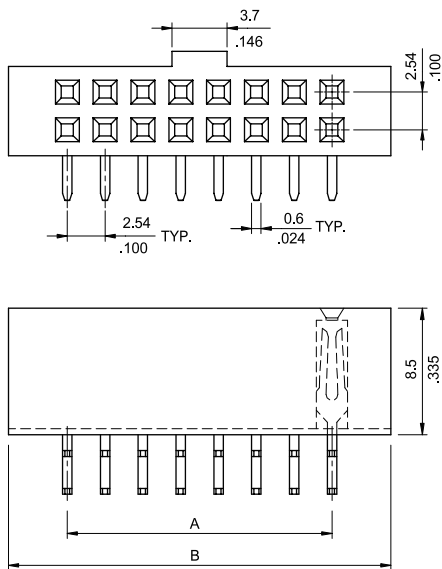
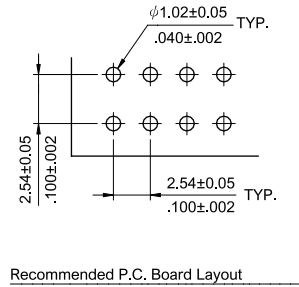
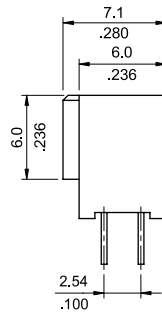

$$A = 2.54 * \text{No. of Spaces}$$

$$B = A + 7.34$$

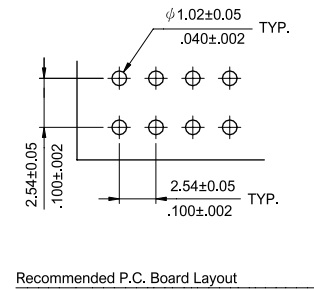
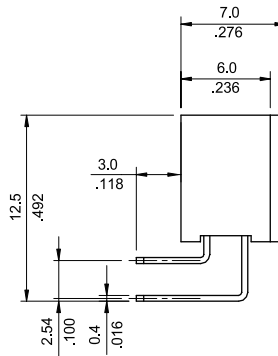

#### Ordering Code

①	②	③	④	⑤	⑥
CB94	64	2	V	1	00

- ① Series No.
- ② No. of Circuits: 06 ~ 64  
(Available: 6,8,10,12,14,16,20,24,26,30,34,40,50,60,64)  
\*Circuits not found above please consult manufacturer

- ③ Plating Code : 2 = Gold flash over Nickel
- ④ Tail Style: V = Vertical  
H = Right Angle
- ⑤ Color: 1 = Black
- ⑥ Other Options: 00 = Standard  
\*Special options consult manufacturer

**CB97 Series 2.54mm(.100") Dual Row Side Entry Female Headers**

☉ Mates with CH81, CH82, CH83 and CH84 series

RoHS Compliant

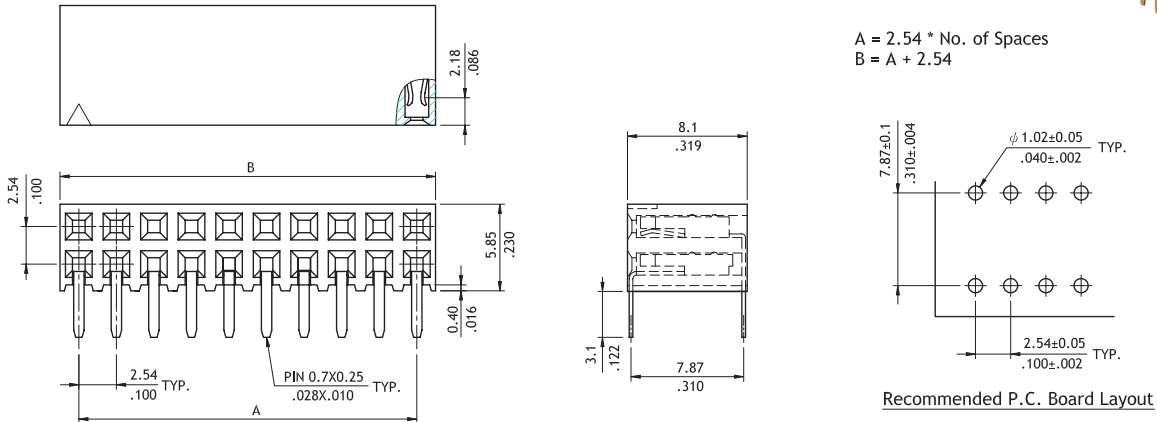
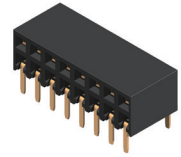

CB

**Ordering Code**

①	②	③	④	⑤	⑥
CB97	40	2	H	1	00

- ① Series No.
  - ② No. of Circuits: 04 ~ 40
  - ③ Plating Code : 2 = Gold flash over Nickel
  - ④ Tail Style: H = Right Angle
  - ⑤ Color: 1 = Black
  - ⑥ Other Options : 00 = Standard
- \*Special options consult manufacturer

**CBA7 Series 2.00mm(.079") Single Row Female Headers**

☉ Mates with CH71, CH72 and CH75 series

**NEW**

RoHS Compliant

P/N: CBA7\*2M100-A

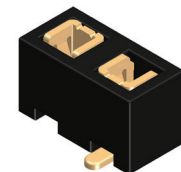
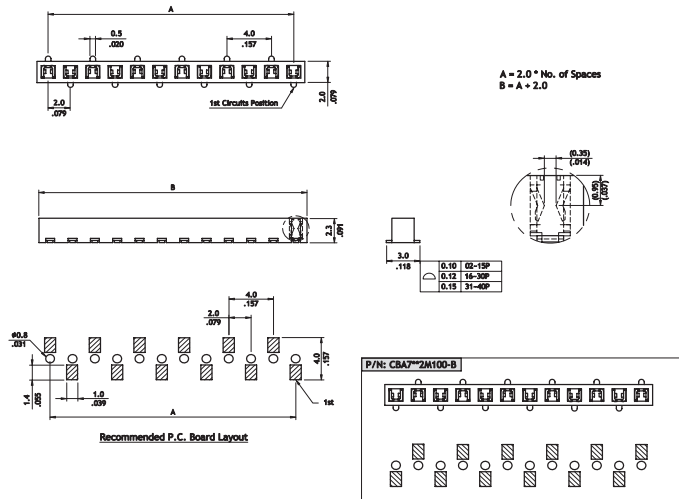

**Ordering Code**

①	②	③	④	⑤	⑥	⑦	⑧
CBA7	12	2	M	1	R	A	- A

- ① Series No.
- ② No. of Circuits: 2~40
- ③ Plating Code: 2 = Gold flash over Nickel
- ④ Tail Style: M = SMT Type
- ⑤ Color: 1 = Black
- ⑥ Packing Option : R = Reel Packing , with pick and place PAD
- ⑦ Option : A = With Pegs
- ⑧ Option : A = A Type B = B Type

BOARD TO BOARD

**CGB1 Series Pogo Pin Connectors**

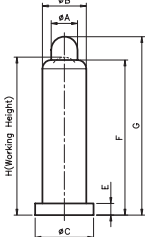
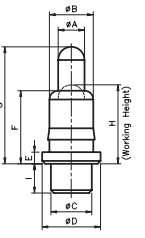
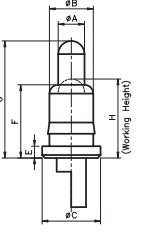
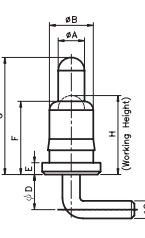
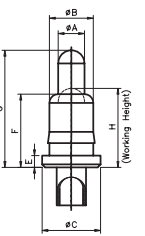
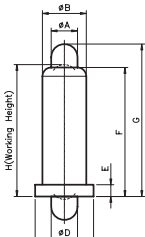
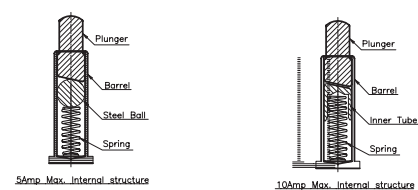
<p>SMT TYPE</p>	 <p>Diagram showing dimensions: <math>\phi B</math>, <math>\phi A</math>, <math>H</math> (Working Height), <math>F</math>, <math>G</math>, <math>E</math>, <math>\phi C</math>.</p>	<table border="1"> <thead> <tr> <th><math>\phi A</math></th> <th><math>\phi B</math></th> <th>SERIES NO.</th> </tr> </thead> <tbody> <tr> <td>0.60mm</td> <td>1.00mm</td> <td>CG01 A Series</td> </tr> <tr> <td>0.90/1.00mm</td> <td>1.50mm</td> <td>CG02 A Series</td> </tr> <tr> <td>1.40mm</td> <td>2.00mm</td> <td>CG03 A Series</td> </tr> <tr> <td>1.80mm</td> <td>2.50mm</td> <td>CG04 A Series</td> </tr> <tr> <td>2.00mm</td> <td>2.85mm</td> <td>CG05 A Series</td> </tr> <tr> <td>2.50mm</td> <td>3.10mm</td> <td>CG06 A Series</td> </tr> </tbody> </table>	$\phi A$	$\phi B$	SERIES NO.	0.60mm	1.00mm	CG01 A Series	0.90/1.00mm	1.50mm	CG02 A Series	1.40mm	2.00mm	CG03 A Series	1.80mm	2.50mm	CG04 A Series	2.00mm	2.85mm	CG05 A Series	2.50mm	3.10mm	CG06 A Series
$\phi A$	$\phi B$	SERIES NO.																					
0.60mm	1.00mm	CG01 A Series																					
0.90/1.00mm	1.50mm	CG02 A Series																					
1.40mm	2.00mm	CG03 A Series																					
1.80mm	2.50mm	CG04 A Series																					
2.00mm	2.85mm	CG05 A Series																					
2.50mm	3.10mm	CG06 A Series																					
<p>DIP TYPE</p>	 <p>Diagram showing dimensions: <math>\phi B</math>, <math>\phi A</math>, <math>H</math> (Working Height), <math>F</math>, <math>G</math>, <math>E</math>, <math>\phi C</math>, <math>\phi D</math>.</p>	<table border="1"> <thead> <tr> <th><math>\phi A</math></th> <th><math>\phi B</math></th> <th>SERIES NO.</th> </tr> </thead> <tbody> <tr> <td>0.60mm</td> <td>1.00mm</td> <td>CG01 B Series</td> </tr> <tr> <td>0.90/1.00mm</td> <td>1.50mm</td> <td>CG02 B Series</td> </tr> <tr> <td>1.40mm</td> <td>2.00mm</td> <td>CG03 B Series</td> </tr> <tr> <td>1.80mm</td> <td>2.50mm</td> <td>CG04 B Series</td> </tr> <tr> <td>2.00mm</td> <td>2.85mm</td> <td>CG05 B Series</td> </tr> <tr> <td>2.50mm</td> <td>3.10mm</td> <td>CG06 B Series</td> </tr> </tbody> </table>	$\phi A$	$\phi B$	SERIES NO.	0.60mm	1.00mm	CG01 B Series	0.90/1.00mm	1.50mm	CG02 B Series	1.40mm	2.00mm	CG03 B Series	1.80mm	2.50mm	CG04 B Series	2.00mm	2.85mm	CG05 B Series	2.50mm	3.10mm	CG06 B Series
$\phi A$	$\phi B$	SERIES NO.																					
0.60mm	1.00mm	CG01 B Series																					
0.90/1.00mm	1.50mm	CG02 B Series																					
1.40mm	2.00mm	CG03 B Series																					
1.80mm	2.50mm	CG04 B Series																					
2.00mm	2.85mm	CG05 B Series																					
2.50mm	3.10mm	CG06 B Series																					
<p>Right Angle SMT TYPE</p>	 <p>Diagram showing dimensions: <math>\phi B</math>, <math>\phi A</math>, <math>H</math> (Working Height), <math>F</math>, <math>G</math>, <math>E</math>, <math>\phi C</math>.</p>	<table border="1"> <thead> <tr> <th><math>\phi A</math></th> <th><math>\phi B</math></th> <th>SERIES NO.</th> </tr> </thead> <tbody> <tr> <td>0.60mm</td> <td>1.00mm</td> <td>CG01 C Series</td> </tr> <tr> <td>0.90/1.00mm</td> <td>1.50mm</td> <td>CG02 C Series</td> </tr> <tr> <td>1.40mm</td> <td>2.00mm</td> <td>CG03 C Series</td> </tr> <tr> <td>1.80mm</td> <td>2.50mm</td> <td>CG04 C Series</td> </tr> <tr> <td>2.00mm</td> <td>2.85mm</td> <td>CG05 C Series</td> </tr> <tr> <td>2.50mm</td> <td>3.10mm</td> <td>CG06 C Series</td> </tr> </tbody> </table>	$\phi A$	$\phi B$	SERIES NO.	0.60mm	1.00mm	CG01 C Series	0.90/1.00mm	1.50mm	CG02 C Series	1.40mm	2.00mm	CG03 C Series	1.80mm	2.50mm	CG04 C Series	2.00mm	2.85mm	CG05 C Series	2.50mm	3.10mm	CG06 C Series
$\phi A$	$\phi B$	SERIES NO.																					
0.60mm	1.00mm	CG01 C Series																					
0.90/1.00mm	1.50mm	CG02 C Series																					
1.40mm	2.00mm	CG03 C Series																					
1.80mm	2.50mm	CG04 C Series																					
2.00mm	2.85mm	CG05 C Series																					
2.50mm	3.10mm	CG06 C Series																					
<p>Right Angle DIP TYPE</p>	 <p>Diagram showing dimensions: <math>\phi B</math>, <math>\phi A</math>, <math>H</math> (Working Height), <math>F</math>, <math>G</math>, <math>E</math>, <math>\phi C</math>, <math>\phi D</math>.</p>	<table border="1"> <thead> <tr> <th><math>\phi A</math></th> <th><math>\phi B</math></th> <th>SERIES NO.</th> </tr> </thead> <tbody> <tr> <td>0.60mm</td> <td>1.00mm</td> <td>CG01 D Series</td> </tr> <tr> <td>0.90/1.00mm</td> <td>1.50mm</td> <td>CG02 D Series</td> </tr> <tr> <td>1.40mm</td> <td>2.00mm</td> <td>CG03 D Series</td> </tr> <tr> <td>1.80mm</td> <td>2.50mm</td> <td>CG04 D Series</td> </tr> <tr> <td>2.00mm</td> <td>2.85mm</td> <td>CG05 D Series</td> </tr> <tr> <td>2.50mm</td> <td>3.10mm</td> <td>CG06 D Series</td> </tr> </tbody> </table>	$\phi A$	$\phi B$	SERIES NO.	0.60mm	1.00mm	CG01 D Series	0.90/1.00mm	1.50mm	CG02 D Series	1.40mm	2.00mm	CG03 D Series	1.80mm	2.50mm	CG04 D Series	2.00mm	2.85mm	CG05 D Series	2.50mm	3.10mm	CG06 D Series
$\phi A$	$\phi B$	SERIES NO.																					
0.60mm	1.00mm	CG01 D Series																					
0.90/1.00mm	1.50mm	CG02 D Series																					
1.40mm	2.00mm	CG03 D Series																					
1.80mm	2.50mm	CG04 D Series																					
2.00mm	2.85mm	CG05 D Series																					
2.50mm	3.10mm	CG06 D Series																					
<p>SOLDER TYPE</p>	 <p>Diagram showing dimensions: <math>\phi B</math>, <math>\phi A</math>, <math>H</math> (Working Height), <math>F</math>, <math>G</math>, <math>E</math>, <math>\phi C</math>.</p>	<table border="1"> <thead> <tr> <th><math>\phi A</math></th> <th><math>\phi B</math></th> <th>SERIES NO.</th> </tr> </thead> <tbody> <tr> <td>0.60mm</td> <td>1.00mm</td> <td>CG01 E Series</td> </tr> <tr> <td>0.90/1.00mm</td> <td>1.50mm</td> <td>CG02 E Series</td> </tr> <tr> <td>1.40mm</td> <td>2.00mm</td> <td>CG03 E Series</td> </tr> <tr> <td>1.80mm</td> <td>2.50mm</td> <td>CG04 E Series</td> </tr> <tr> <td>2.00mm</td> <td>2.85mm</td> <td>CG05 E Series</td> </tr> <tr> <td>2.50mm</td> <td>3.10mm</td> <td>CG06 E Series</td> </tr> </tbody> </table>	$\phi A$	$\phi B$	SERIES NO.	0.60mm	1.00mm	CG01 E Series	0.90/1.00mm	1.50mm	CG02 E Series	1.40mm	2.00mm	CG03 E Series	1.80mm	2.50mm	CG04 E Series	2.00mm	2.85mm	CG05 E Series	2.50mm	3.10mm	CG06 E Series
$\phi A$	$\phi B$	SERIES NO.																					
0.60mm	1.00mm	CG01 E Series																					
0.90/1.00mm	1.50mm	CG02 E Series																					
1.40mm	2.00mm	CG03 E Series																					
1.80mm	2.50mm	CG04 E Series																					
2.00mm	2.85mm	CG05 E Series																					
2.50mm	3.10mm	CG06 E Series																					
<p>DOUBLE HEADED TYPE</p>	 <p>Diagram showing dimensions: <math>\phi B</math>, <math>\phi A</math>, <math>H</math> (Working Height), <math>F</math>, <math>G</math>, <math>E</math>, <math>\phi C</math>, <math>\phi D</math>.</p>	<table border="1"> <thead> <tr> <th><math>\phi A</math></th> <th><math>\phi B</math></th> <th>SERIES NO.</th> </tr> </thead> <tbody> <tr> <td>0.60mm</td> <td>1.00mm</td> <td>CG01 F Series</td> </tr> <tr> <td>0.90/1.00mm</td> <td>1.50mm</td> <td>CG02 F Series</td> </tr> <tr> <td>1.40mm</td> <td>2.00mm</td> <td>CG03 F Series</td> </tr> <tr> <td>1.80mm</td> <td>2.50mm</td> <td>CG04 F Series</td> </tr> <tr> <td>2.00mm</td> <td>2.85mm</td> <td>CG05 F Series</td> </tr> <tr> <td>2.50mm</td> <td>3.10mm</td> <td>CG06 F Series</td> </tr> </tbody> </table>	$\phi A$	$\phi B$	SERIES NO.	0.60mm	1.00mm	CG01 F Series	0.90/1.00mm	1.50mm	CG02 F Series	1.40mm	2.00mm	CG03 F Series	1.80mm	2.50mm	CG04 F Series	2.00mm	2.85mm	CG05 F Series	2.50mm	3.10mm	CG06 F Series
$\phi A$	$\phi B$	SERIES NO.																					
0.60mm	1.00mm	CG01 F Series																					
0.90/1.00mm	1.50mm	CG02 F Series																					
1.40mm	2.00mm	CG03 F Series																					
1.80mm	2.50mm	CG04 F Series																					
2.00mm	2.85mm	CG05 F Series																					
2.50mm	3.10mm	CG06 F Series																					
<p>HIGH POWER TYPE</p>	 <p>Diagram showing internal structure for 5Amp Max. and 10Amp Max. components: Plunger, Barrel, Steel Ball, Spring, Inner Tube.</p>																						

CB

BOARD TO BOARD

P/N CGB1\*\*P\*\*M000-LF

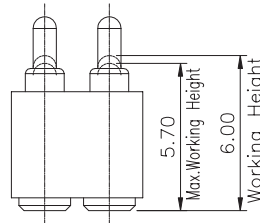
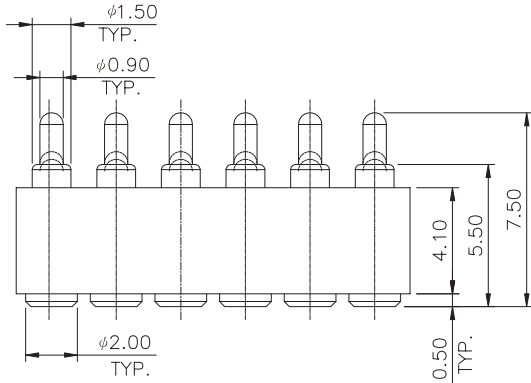
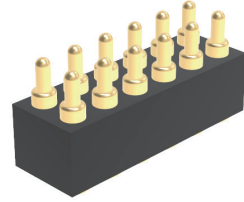
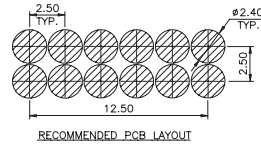
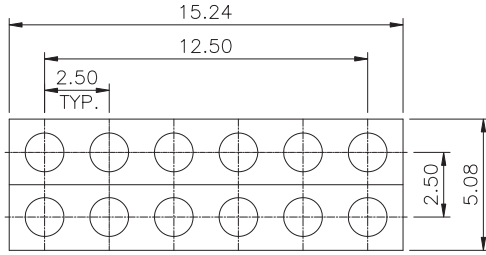

CB

P/N CGB1\*\*S\*\*M000-LF

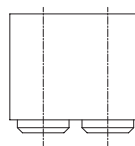
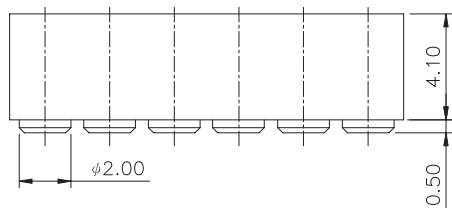
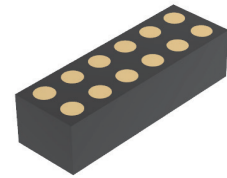
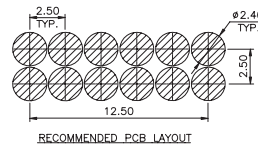
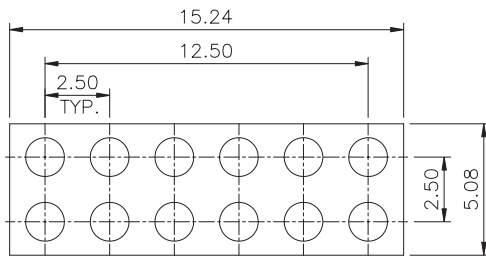

**Ordering Code**

① CGB ② 1 ③ S ④ 08 ⑤ M ⑥ 000 ⑦ - LF

- ① Series No.
- ② No. of Circuits: 12
- ③ S = Receptacle
- ④ Plating Code: 08 = Selective 10μ" Gold flash over Nickel
- ⑤ Tail Style : M = Top SMT Type
- ⑥ Option : 000 = Standard
- ⑦ LF = For Lead Free IR process

① CGB ② 1 ③ P ④ 8 ⑤ 8 ⑥ M ⑦ 000 ⑧ - LF

- ① Series No.
- ② No. of Circuits: 12
- ③ P = Plug
- ④ Plunger Plating Code:  
8 = Selective 10μ" Gold flash over Nickel
- ⑤ Barrel Plating Code:  
8 = Selective 10μ" Gold flash over Nickel
- ⑥ Tail Style : M = Top SMT Type
- ⑦ Options :000= Standard
- ⑧ LF = For Lead Free IR process

BOARD TO BOARD

**CHC3 Series 0.80mm(.031") Dual Row SMT Pin Headers**

- ⊙ Mate with CBC3 Series
- ⊙ SMT Tail
- ⊙ With mounting Pegs
- ⊙ High temperature plastic, Color Black

RoHS Compliant

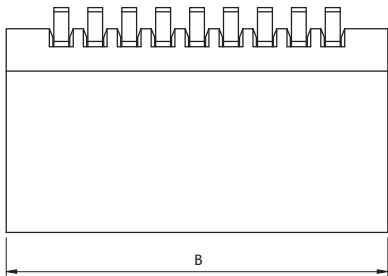
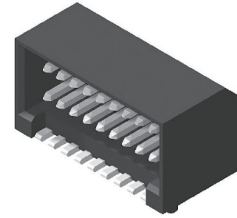

A = 0.8 x No. of Spaces  
 B = A + 2.6  
 C = A + 1.8

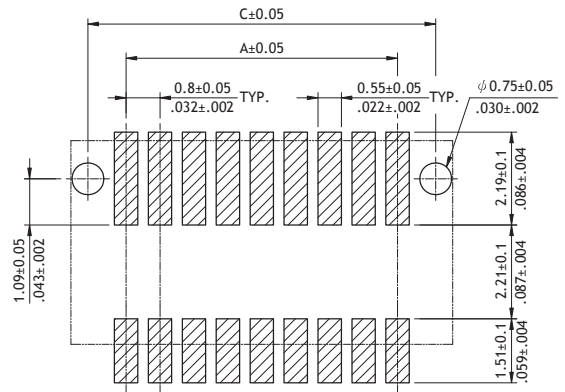

Recommended PCB Layout

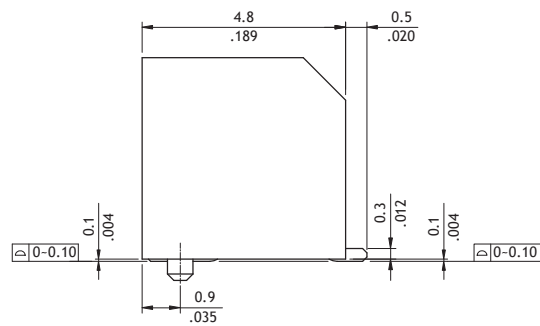
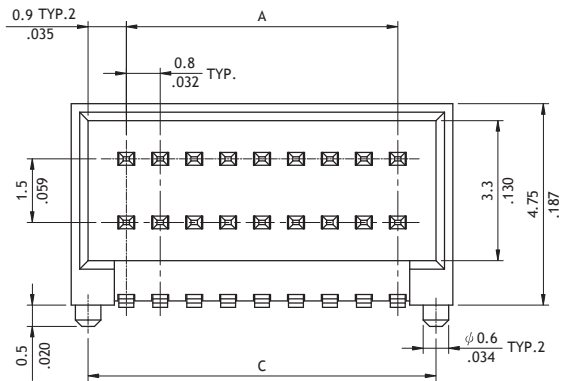

**Ordering Code**

①	②	③	④	⑤	⑥	⑦
CHC3	36	2	M	1	R	0

- ① Series No.
- ② No. of Circuits: 06 ~ 36
- ③ Plating Code:  
 1 = Tin over Nickel  
 2 = Gold flash over Nickel
- ④ Tail & Mounting Style: M = SMT Type
- ⑤ Color: 1 = Black

- ⑥ Packing:  
 R = Tape & Reel  
 T = Tube
- ⑦ Other Options: 0 = Standard  
 \*Special options consult manufacturer

**CH07 Series 1.00mm(.039") SMT Row Board Mount Connectors**

☉ Mate with CB03 series

RoHS Compliant 

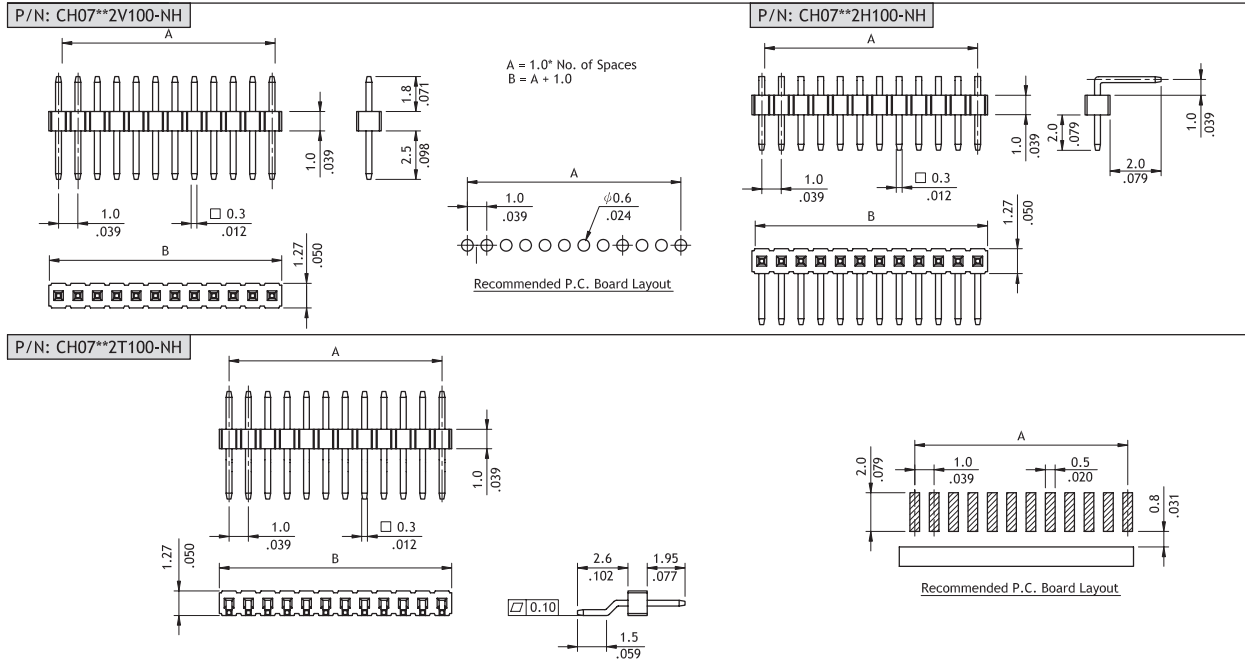

**Ordering Code**

① ② ③ ④ ⑤ ⑥ ⑦  
**CH07 26 2 T 1 00 - NH**

- ① Series No.
- ② No. of Circuits: 2 ~ 40
- ③ Plating Code: 2 = Gold flash over Nickel
- ④ Tail Style: T = Side Entry SMT Type  
 V = Straight DIP Type  
 H = Right Angle DIP Type
- ⑤ Color: 1 = Black
- ⑥ Pin Length Options:
- ⑦ NH = For Lead Free IR process and Halogen- Free

**CH16 Series 1.00mm(.039") Dual Row Pin Headers**

☉ Mate with CB12 series

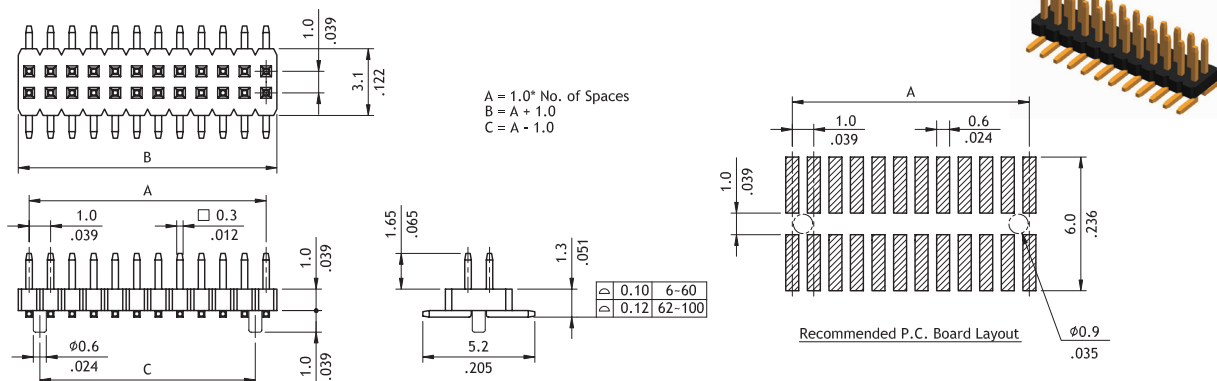

**Ordering Code**

① ② ③ ④ ⑤ ⑥ ⑦ ⑧  
**CH16 26 2 M 1 00 - 0 0**

- ① Series No.
- ② No. of Circuits: 6 ~ 100
- ③ Plating Code: 2 = Gold flash over Nickel
- ④ Tail Style: M = SMT Type
- ⑤ Color: 1 = Black
- ⑥ Pin Length Options:
- ⑦ Pin Size: 0 = Without Pegs  
 P = With Pegs
- ⑧ Packing: 0 = Without Pick & Place Pad (Tube)

# CH01 Series 1.27mm(.050") Single Row Pin Headers

☉ Mate with CB01 series

RoHS Compliant

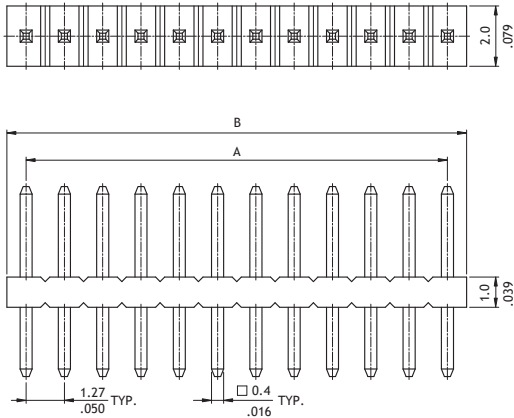
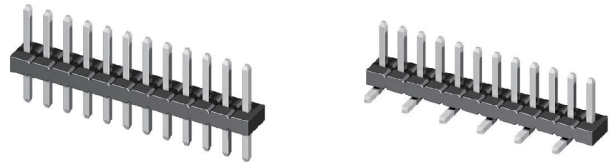

A = 1.27 X No. of Spaces  
 B = A + 1.27  
 Pin overall length 20.0mm max.

Option Code	Pin Dimension	
	C	D
00	3.0(.118)	2.3(.091)
01	3.0(.118)	1.6(.063)
02	3.5(.138)	1.8(.071)
03	3.8(.150)	1.5(.059)

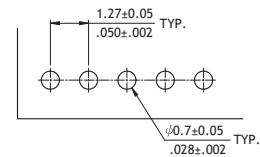
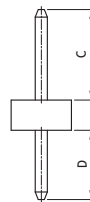

Recommended P.C. Board Layout

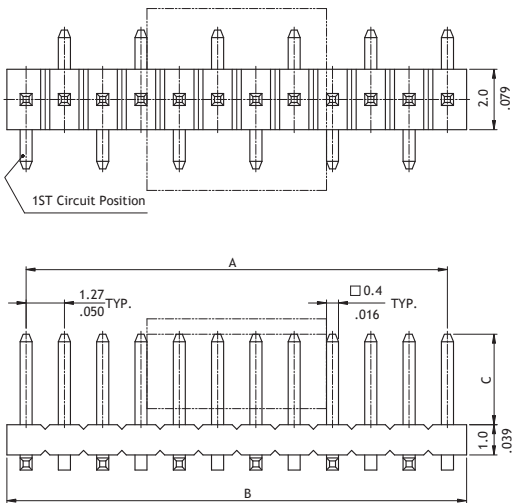

A = 1.27 X No. of Spaces  
 B = A + 1.27

Option Code	Pin Dimension		
	C	D	F
00	3.0(.118)	1.5(.059)	4.6(.181)

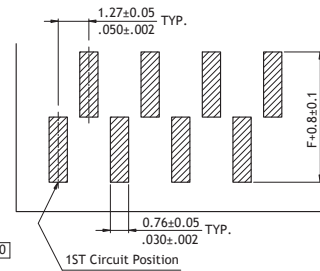
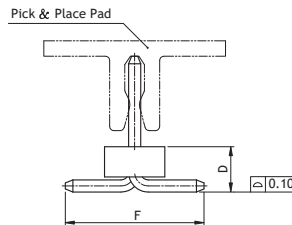

Recommended P.C. Board Layout

## Ordering Code

① ② ③ ④ ⑤ ⑥ ⑦ ⑧  
**CH01 50 2 V 1 00 - 00 - NH**

- ① Series No.
- ② No. of Circuits: 04 ~ 50
- ③ Plating Code : 2 = Gold flash over Nickel
- ④ Tail & Mounting Style:  
 V = Vertical DIP Type  
 M = SMT Type
- ⑤ 1=Color Black

- ⑥ Other Options: 00 = Standard  
 \*See option code table  
 \*Consult manufacturer for customized pin length
- ⑦ Packing Options:  
 00 = Without Pick & Place Pad (Tube)  
 0P = With Pick & Place Pad (Tape & Reel)  
 \*Code 7 for SMT Type only
- ⑧ NH = For Lead Free soldering process and Halogen- Free

**CH02 Series 1.27mm(.050") Single Row Pin Headers**

☉ Mate with CB01 series

RoHS Compliant

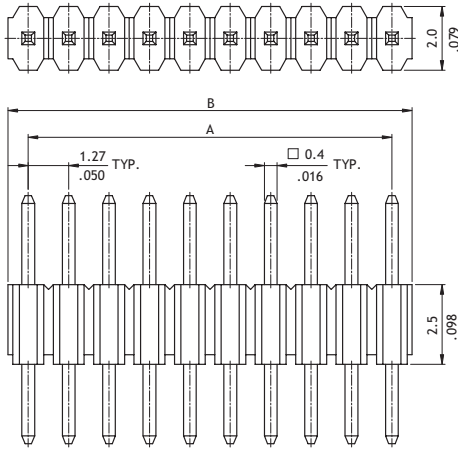
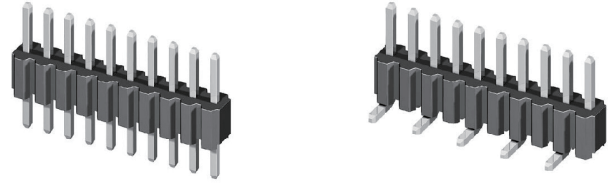

A = 1.27 X No. of Spaces  
 B = A + 1.27  
 Pin overall length 20.0mm max.

Option Code	Pin Dimension	
	C	D
00	3.0(.118)	2.3(.091)

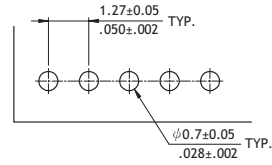
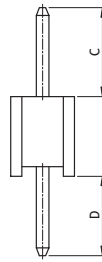

Recommended P.C. Board Layout

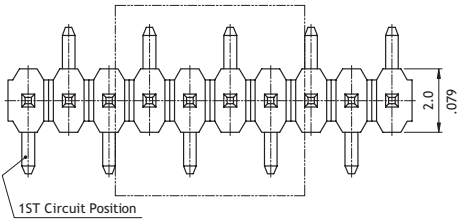

A = 1.27 X No. of Spaces  
 B = A + 1.27

Option Code	Pin Dimension		
	C	D	F
00	3.0(.118)	2.92(.115)	4.6(.181)
01	8.0(.315)	3.0(.118)	4.6(.181)

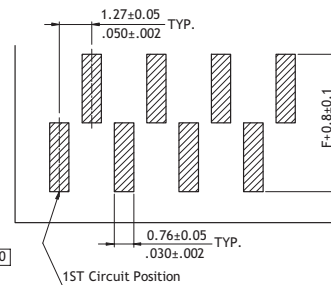
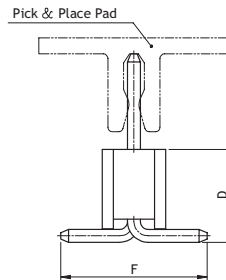
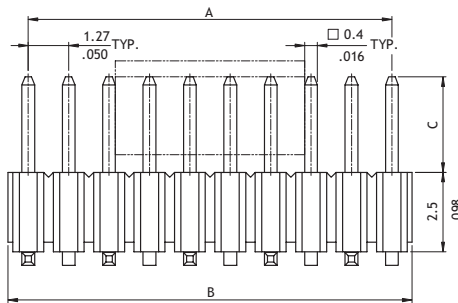

Recommended P.C. Board Layout

**Ordering Code**

① ② ③ ④ ⑤ ⑥ ⑦ ⑧  
**CH02 50 2 V 1 00 - 00 - NH**

- ① Series No.
- ② No. of Circuits: 04 ~ 50
- ③ Plating Code : 2 = Gold flash over Nickel
- ④ Tail & Mounting Style:  
 V = Vertical DIP Type  
 M = Vertical SMT Type
- ⑤ 1 = Color Black
- ⑥ Other Options: 00 = Standard

- ⑦ Packing Options:  
 00 = Without Pick & Place Pad (Tube)  
 0P = With Pick & Place Pad (Tape & Reel)  
 \*Code 7 for SMT Type only
- ⑧ NH = For Lead Free soldering process and Halogen-Free

## CH03 Series 1.27mm(.050") Single Row Dual Bodies Pin Headers

☉ Mate with CB01 series

RoHS Compliant

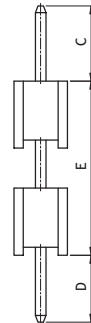
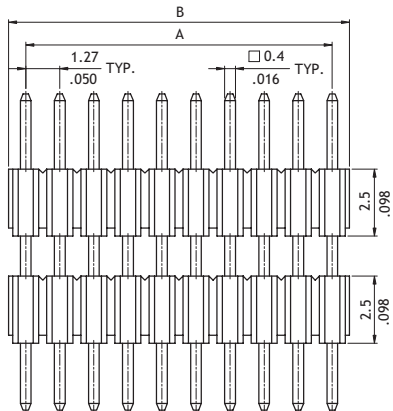
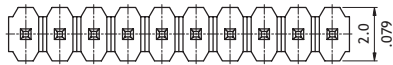

A = 1.27 X No. of Spaces  
 B = A + 1.27  
 E = 5.0 min.  
 Pin overall length 20.0mm max.

Option Code	Pin Dimension		
	C	D	E
00	3.0(.118)	2.3(.091)	5.0(.197)

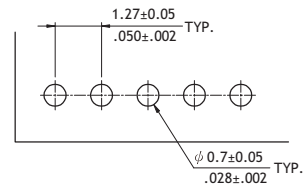

Recommended P.C. Board Layout

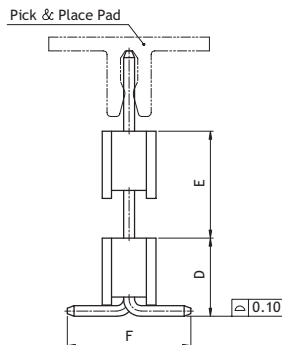
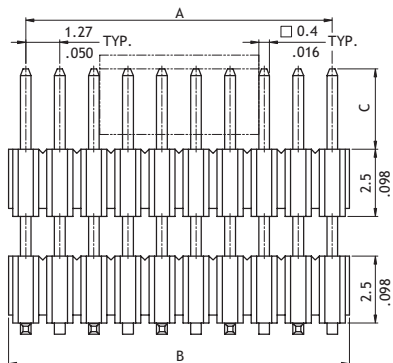
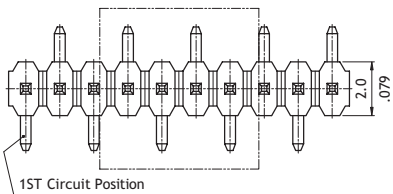

A = 1.27 X No. of Spaces  
 B = A + 1.27

Option Code	Pin Dimension			
	C	D	E	F
00	3.0(.118)	2.92(.115)	2.5(.098)	5.0(.197)

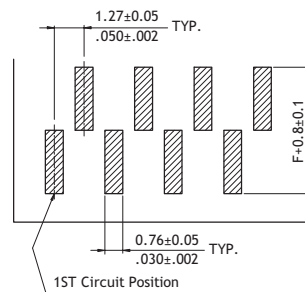

Recommended P.C. Board Layout

### Ordering Code

① ② ③ ④ ⑤ ⑥ ⑦ ⑧  
**CH03 50 2 V 1 00 - 00 - NH**

- ① Series No.
- ② No. of Circuits: 04 ~ 50
- ③ Plating Code : 2 = Gold flash over Nickel
- ④ Tail & Mounting Style:  
 V = Vertical DIP Type  
 M = Vertical SMT Type
- ⑤ 1 = Nylon 6T, Color Black

- ⑥ Other Options:  
 00 = Standard  
 \*See option code table  
 \*Consult manufacturer for customized pin length
- ⑦ Packing Options:  
 00 = Without Pick & Place Pad (Tube)  
 0P = With Pick & Place Pad (Tape & Reel)  
 \*Code 7 for SMT Type only
- ⑧ NH = For Lead Free soldering process and Halogen-Free

**CH06 Series 1.27mm(.049") Straight SMT Dual Row Shrouded Headers**

- ⊙ Mate with CA02 series
- ⊙ Box type with positive locking latch
- ⊙ With polarizing slot

RoHS Compliant 

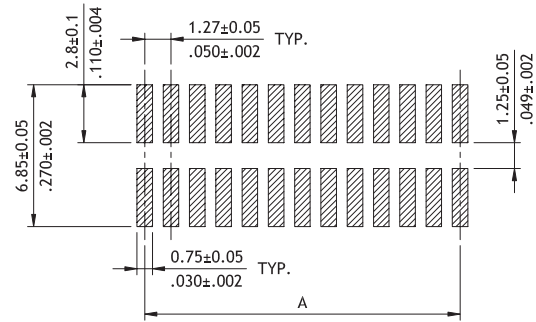
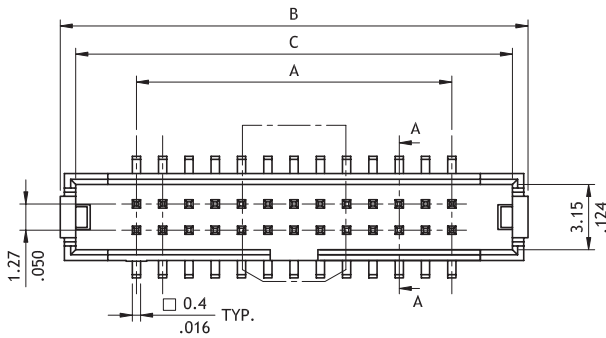
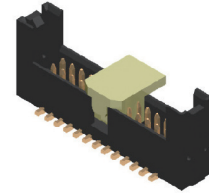

Recommended P.C. Board Layout

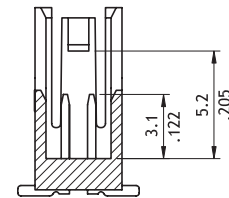
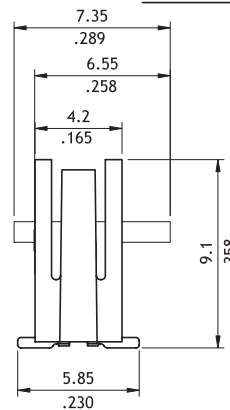
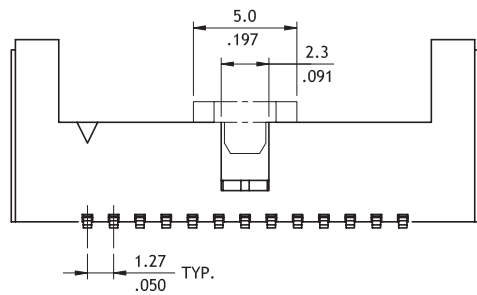

SEC.A-A

Circuits	Dimension		
	A	B	C
6	2.54(.100)	9.91(.390)	8.40(.331)
10	5.08(.200)	12.45(.490)	10.94(.431)
14	7.62(.300)	14.99(.590)	13.48(.531)
26	15.24(.600)	22.61(.890)	21.10(.831)

**Ordering Code**

① CH06 ② 26 ③ 2 ④ M ⑤ A ⑥ L0 ⑦ -NH

- ① Series No.
- ② No. of Circuits: 6,10,14,26
- ③ Plating Code : 2 = Gold flash over Nickel
- ④ Tail Style: M = SMT Type
- ⑤ Color: A = Black
- ⑥ Other Options: L0 = Latch Type
- ⑦ NH = For Lead Free IR process and Halogen- Free

## CH51 Series 1.27mm(.050") Dual Row Pin Headers

☉ Mate with CB50 and CBC1 series

RoHS Compliant



P/N CH51\*\*2V100-NH

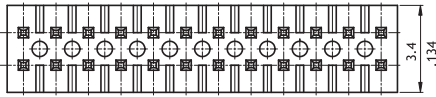

A = 1.27 X No. of Spaces  
 B = A + 1.27  
 Pin overall length 20.0mm max.

Option Code	Pin Dimension	
	C	D
00	3.0(.118)	2.3(.091)

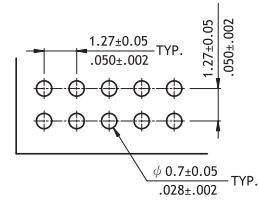
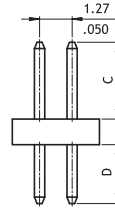
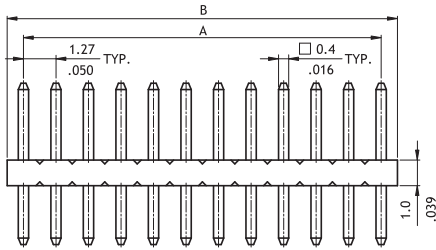

Recommended PCB Layout

P/N CH51\*\*2H100-NH

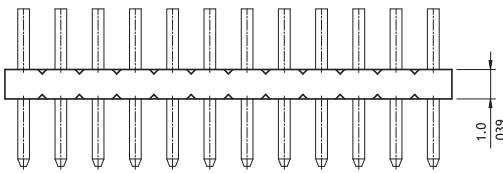

A = 1.27 X No. of Spaces  
 B = A + 1.27

Option Code	Pin Dimension		
	C	D	E
00	2.0(.079)	2.3(.091)	1.6(.063)

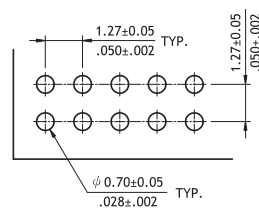
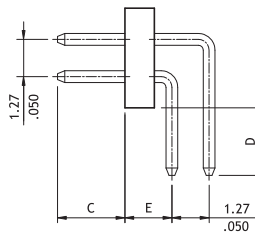
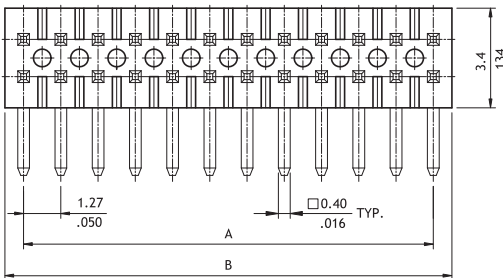

Recommended PCB Layout

### Ordering Code

① CH ② 51 ③ X1 ④ 2 ⑤ V ⑥ 1 ⑦ 00 - NH

- ① Series No.
- ② No. of Circuits: 06 ~100 (X1 = 100)
- ③ Plating Code : 2 = Gold flash over Nickel
- ④ Tail & Mounting Style:  
 V = Vertical DIP Type  
 H = Right Angle DIP Type

- ⑤ 1 = Color Black
- ⑥ Other Options:  
 00 = Standard  
 \*See option code table  
 \*Consult manufacturer for customized pin length
- ⑦ NH = For Lead Free soldering process and Halogen- Free

**CH51 Series 1.27mm(.050") Dual Row SMT Pin Headers**

☉ Mate with CB50 and CBC1 series

RoHS Compliant  

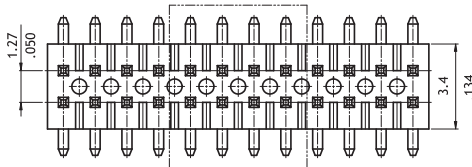
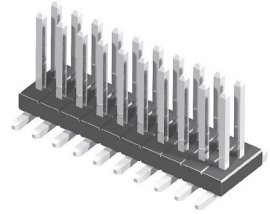

A = 1.27 X No. of Spaces  
 B = A + 1.27  
 H = A - 1.27

Option Code	Pin Dimension		
	C	D	F
00	3.0(.118)	1.5(.059)	5.5(.217)

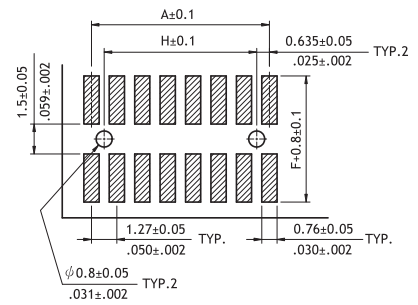
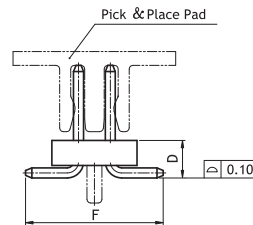
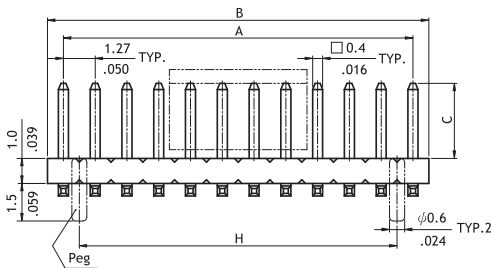

Recommended PCB Layout

**Ordering Code**

① CH51 ② X1 ③ 2 ④ M ⑤ 1 ⑥ 00-0 ⑦ 0 ⑧ -NH

- ① Series No.
- ② No. of Circuits: 06 ~ 100 (X1 = 100)
- ③ Plating Code: 2 = Gold flash over Nickel
- ④ Tail & Mounting Style: M = Vertical SMT Type
- ⑤ 1= Color Black
- ⑥ Other Options: 00 = Standard  
 \*See option code table  
 \*Consult manufacturer for customized pin length
- ⑦ Pegs Options:  
 P = With Pegs  
 0 = Without Peg
- ⑧ Packing Options:  
 0 = Without Pick & Place Pad (Tube)  
 P = With Pick & Place Pad (Tape & Reel)
- ⑨ NH = For Lead Free IR process and Halogen- Free

## CH52 Series 1.27mm(.050") Dual Row Pin Headers

☉ Mate with CB50 and CBC1 series

RoHS Compliant

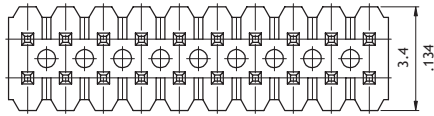
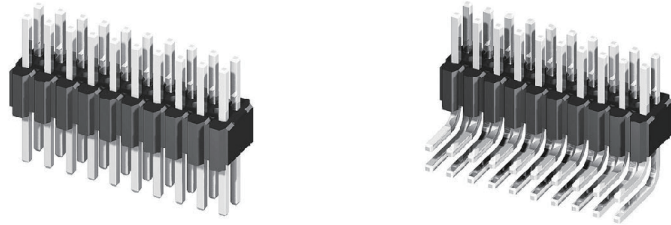

Option Code	Pin Dimension	
	C	D
00	3.0(.118)	2.3(.091)

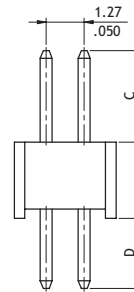
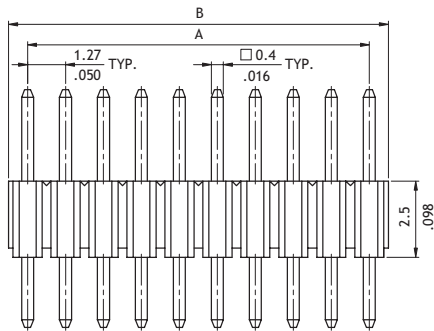

A = 1.27 X No. of Spaces  
 B = A + 1.27  
 Pin overall length 20.0mm max.

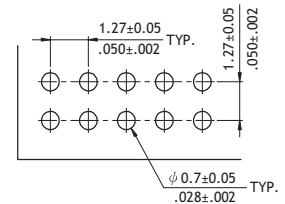

Recommended P.C. Board Layout

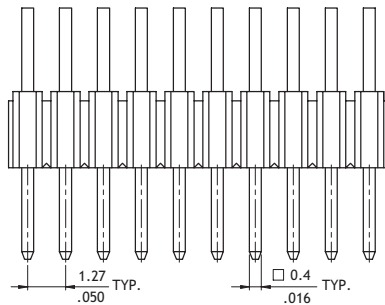

Option Code	Pin Dimension		
	C	D	G
00	3.0(.118)	2.3(.091)	1.27(.050)

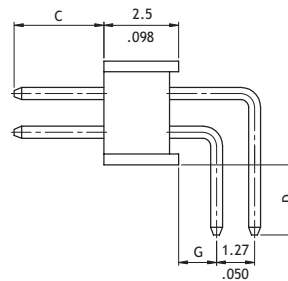
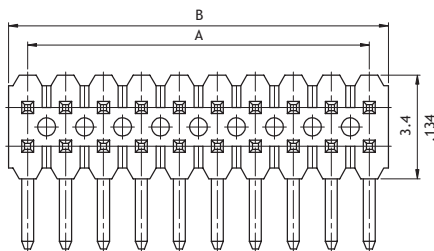

### Ordering Code

① CH52 ② 60 ③ 2 ④ V ⑤ A ⑥ 00 - ⑦ NH

- ① Series No.
- ② No. of Circuits: 06 ~ 60
- ③ Plating Code : 2 = Gold flash over Nickel
- ④ Tail & Mounting Style:  
 V = Vertical DIP Type  
 H = Right Angle DIP Type

- ⑤ Insulator Material & Color:  
 A = Color Black
- ⑥ Other Options: 00 = Standard  
 \*See option code table  
 \*Consult manufacturer for customized pin length
- ⑦ NH = For Lead Free IR process  
 and Halogen- Free

**CH52 Series 1.27mm(.050") Dual Row SMT Pin Headers**

☉ Mate with CB50 and CBC1 series

RoHS Compliant

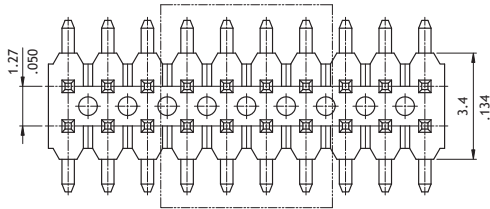
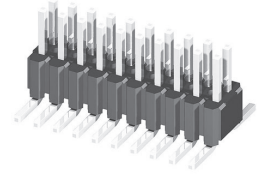

A = 1.27 X No. of Spaces  
 B = A + 1.27  
 H = A - 1.27

Option Code	Pin Dimension		
	C	D	F
00	3.0(.118)	2.92(.115)	5.5(.217)

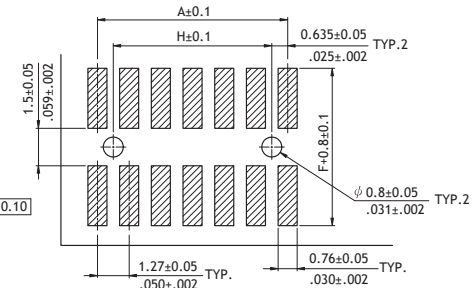
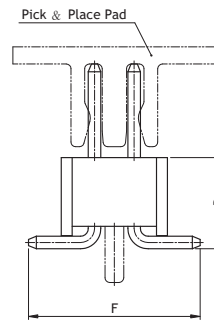
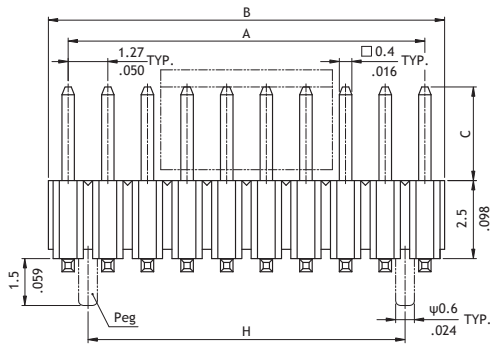

Recommended P.C. Board Layout

**Ordering Code**

① ② ③ ④ ⑤ ⑥ ⑦ ⑧ ⑨  
**CH52 60 2 M 1 00 - 0 0 - NH**

- ① Series No.
- ② No. of Circuits: 06 ~ 60
- ③ Plating Code: 2 = Gold flash over Nickel
- ④ Tail & Mounting Style: M = SMT Type
- ⑤ 1 = Color Black
- ⑥ Other Options: 00 = Standard  
 \*See option code table  
 \*Consult manufacturer for customized pin length

- ⑦ Pegs Options:  
 0 = Without Peg  
 P = With Pegs
- ⑧ Packing Options:  
 0 = Without Pick & Place Pad (Tube)  
 P = With Pick & Place Pad (Tape & Reel)
- ⑨ NH = For Lead Free IR process  
 and Halogen- Free

## CH57 Series 1.27mm(.050") Dual Row Dual Bodies Pin Headers

☉ Mate with CB50 and CBC1 series

RoHS Compliant

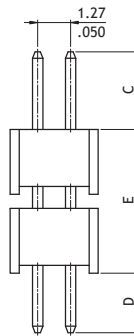
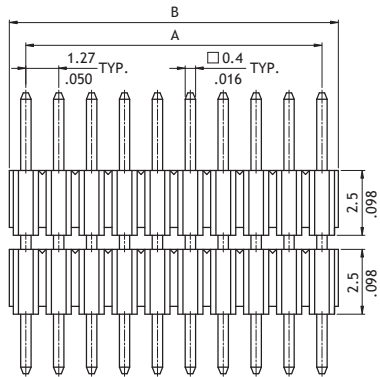
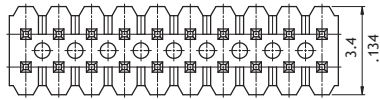

A = 1.27 X No. of Spaces  
 B = A + 1.27  
 Pin overall length 20.0mm max.

Option Code	Pin Dimension		
	C	D	E
00	3.0(.118)	2.3(.091)	5.0(.197)

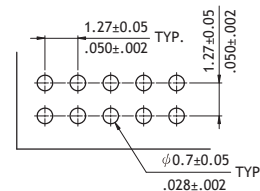

Recommended P.C. Board Layout

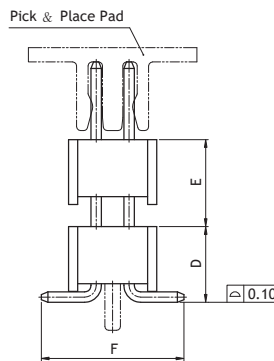
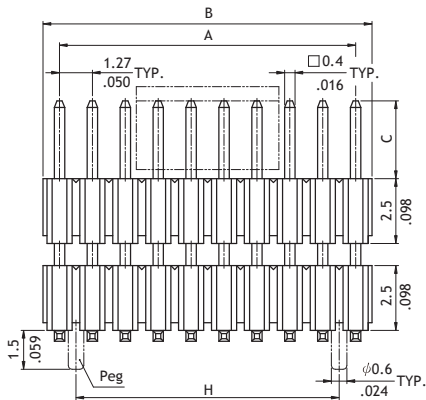
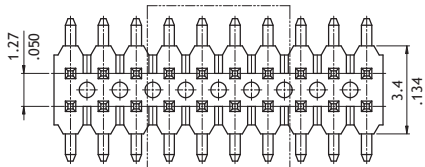

A = 1.27 X No. of Spaces  
 B = A + 1.27  
 H = A - 1.27

Option Code	Pin Dimension			
	C	D	E	F
00	3.0(.118)	2.92(.115)	2.5(.098)	5.5(.217)

Recommended P.C. Board Layout

### Ordering Code

① ② ③ ④ ⑤ ⑥ ⑦ ⑧ ⑨  
**CH57 60 2 M 1 00 - 0 0 - NH**

- ① Series No.
- ② No. of Circuits: 06 ~60
- ③ Plating Code:  
2 = Gold flash over Nickel
- ④ Tail & Mounting Style:  
V = Vertical DIP Type  
M = Vertical SMT Type

- ⑤ Insulator Material & Color:  
1 = Color Black
- ⑥ Other Options:  
00 = Standard  
\*See option code table  
\*Consult manufacturer  
for  
customized pin length

- ⑦ Insulator Material & Color:  
0 = Without Peg  
P = With Pegs
- ⑧ Packing Options:  
0 = Without Pick & Place Pad (Tube)  
P = With Pick & Place Pad (Tape & Reel)  
\*Code 7 and 8 for SMT Type only
- ⑨ NH = For Lead Free IR process  
and Halogen- Free

CHC2 Series 1.27mm(.050") Dual Row Pin Headers

☉ Mate with CBC1 series

RoHS Compliant

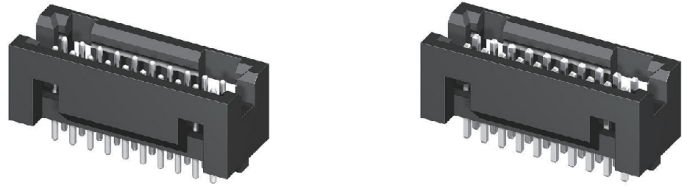

P/N CHC2\*\*\*V1\*\*-1

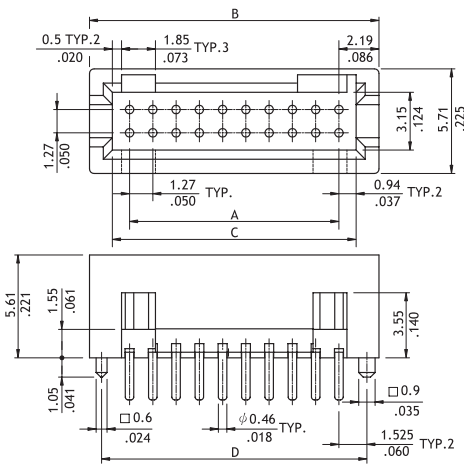

A = 1.27 X No. of Spaces  
 B = A + 4.38  
 C = A + 1.88  
 D = A + 3.05

Option Code	Pin Dimension	
	E	F
00	3.05(.121)	2.3(.091)

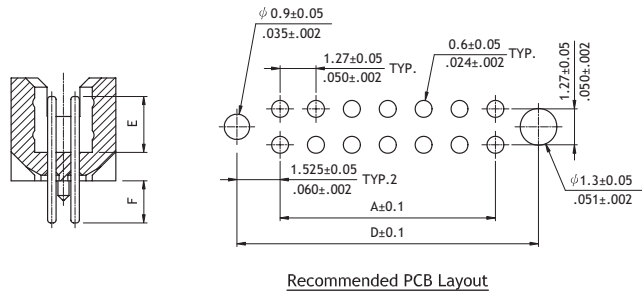

P/N CHC2\*\*\*V1\*\*-2

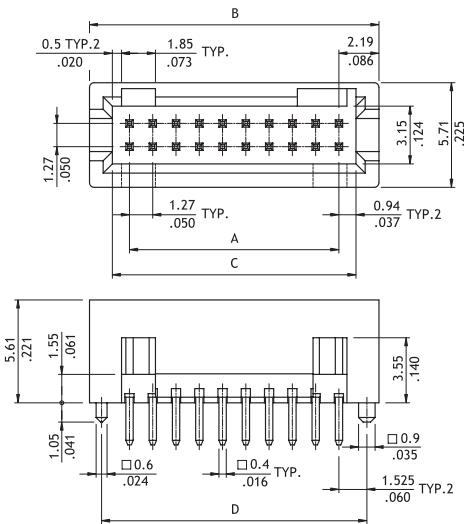

A = 1.27 X No. of Spaces  
 B = A + 4.38  
 C = A + 1.88  
 D = A + 3.05

Option Code	Pin Dimension	
	E	F
00	3.05 (.121)	2.3(.091)

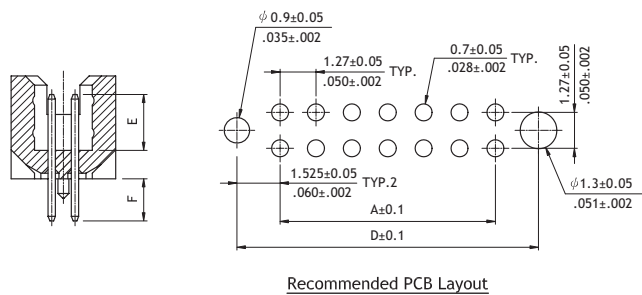

Ordering Code

① ② ③ ④ ⑤ ⑥ ⑦  
**CHC2 60 2 V 1 00 - 1**

- ① Series No.
- ② No. of Circuits: 10 ~ 20
- ③ Plating Code: 2 = Gold flash over Nickel
- ④ Tail & Mounting Style:  
V = Vertical DIP Type
- ⑤ 1 = Color Black

- ⑥ Other Options:  
00 = Standard  
\*See option code table  
\*Consult manufacturer for customized pin length
- ⑦ Pin Size:  
1 = 0.46mm Round Pin  
2 = 0.4mm Square Pin

## CHC2 Series 1.27mm(.050") Dual Row Pin Headers

☉ Mate with CBC1 series

RoHS Compliant

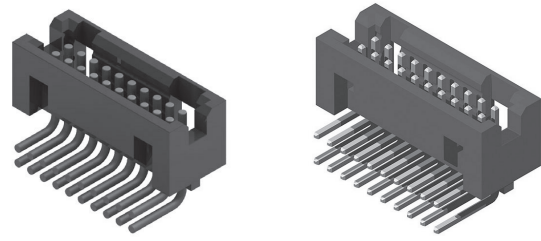

P/N: CHC2\*\*\*H100-1\*

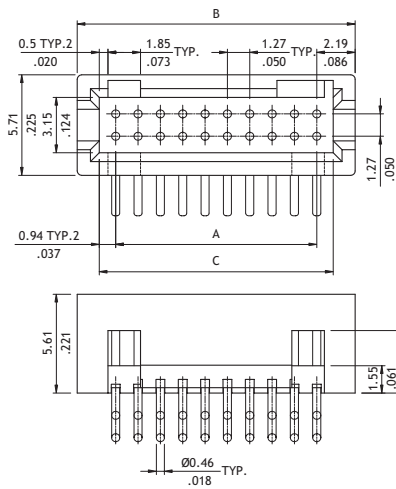

P/N: CHC2\*\*\*H100-2\*

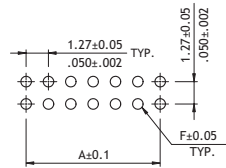
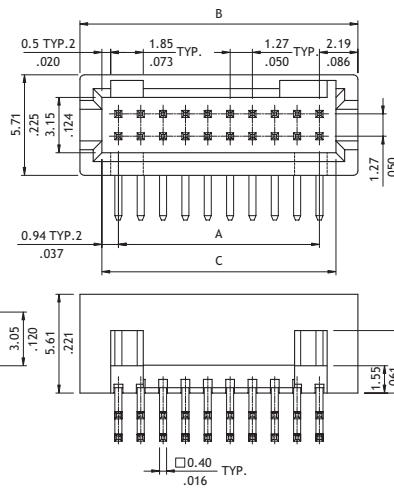

Recommended P.C. Board Layout

A = 1.27 X No. of Spaces  
 B = A + 4.38  
 C = A + 1.88  
 F = □0.70mm ( Square Pin )  
 Ø0.60mm ( Round Pin )

### Ordering Code

① ② ③ ④ ⑤ ⑥ ⑦  
**CHC2 60 2 H 1 00 - 10**

- ① Series No.
- ② No. of Circuits: 10~60
- ③ Plating Code: 2 = Gold flash over Nickel
- ④ Tail & Mounting Style:  
 H = Right Angle DIP Type
- ⑤ 1 = Color Black

- ⑥ Other Options: 00 = Standard  
 \*See option code table  
 \*Consult manufacturer for customized pin length
- ⑦ Pin Size:  
 10 = 0.46mm Round Pin  
 20 = 0.4mm Square Pin

CHC2 Series 1.27mm(.050") Dual Row SMT Pin Headers

☉ Mate with CBC1 series

RoHS Compliant

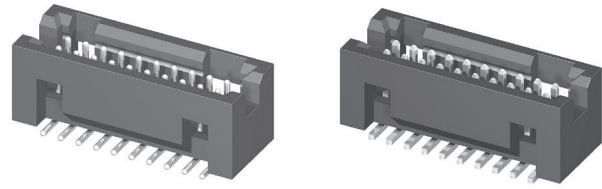

P/N: CHC2\*\*\*M1\*\*-1\*

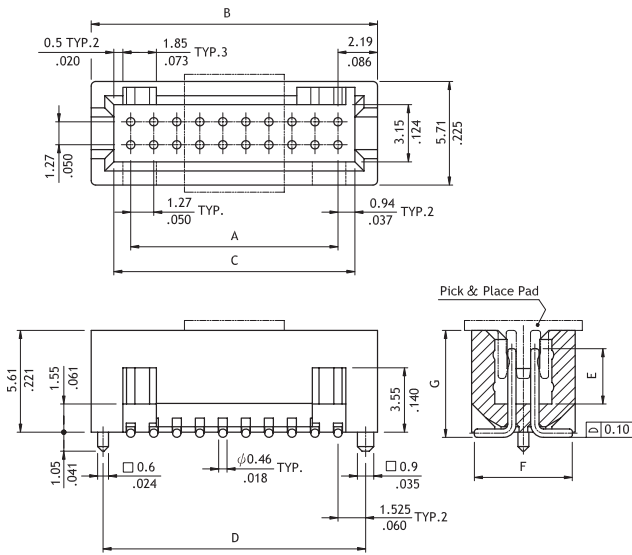

P/N: CHC2\*\*\*M1\*\*-2\*

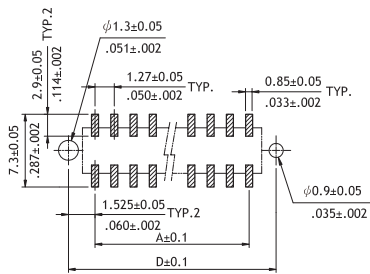
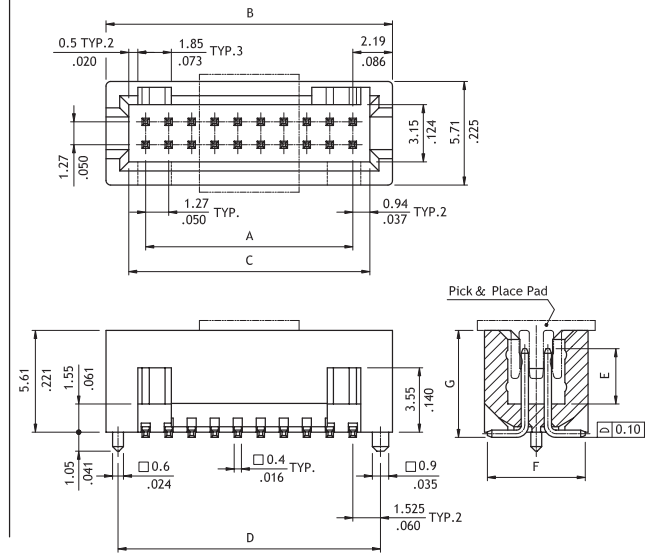

A = 1.27 X No. of Spaces  
 B = A + 4.38  
 C = A + 1.88  
 D = A + 3.05

Option Code	Pin Dimension		
	E	F	G
00	3.05(.120)	5.4(.213)	5.9(.232)

Ordering Code

① ② ③ ④ ⑤ ⑥ ⑦ ⑧ ⑨  
**CHC2 X1 2 M 1 00 - 2 0 - NH**

- ① Series No.
- ② No. of Circuits: 10 ~ 60
- ③ Plating Code: 2 = Gold flash over Nickel
- ④ Tail & Mounting Style: M = Vertical SMT Type
- ⑤ 1 = Color Black
- ⑥ Other Options: 00 = Standard  
 \*See option code table  
 \*Consult manufacturer for customized pin length

- ⑦ Pin Size:  
 1= 0.46mm Round Pin  
 2= 0.4mm Square Pin
- ⑧ Packing Options:  
 0 = Without Pick & Place Pad (Tube)  
 P = With Pick & Place Pad (Tape & Reel)
- ⑨ NH = For Lead Free IR process and Halogen- Free

**CH60 Series 1.27mm(.050") Right Angle Dual Row Board Mount Pin Header**

☉ Mate with CBC1 series

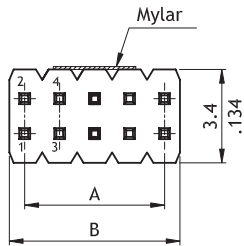
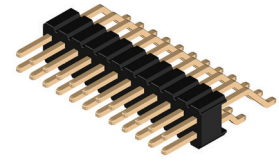

DIM. A = 1.27 X No. of Spaces  
 DIM. B = DIM. A + 1.12

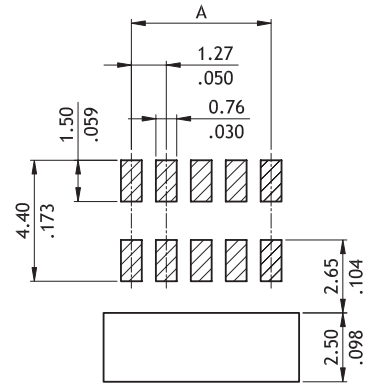
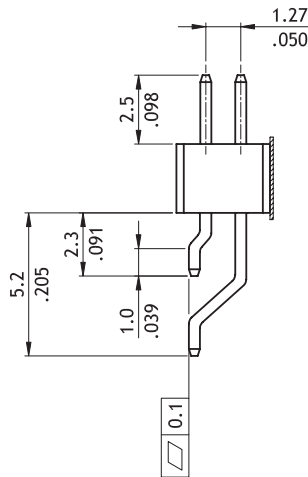
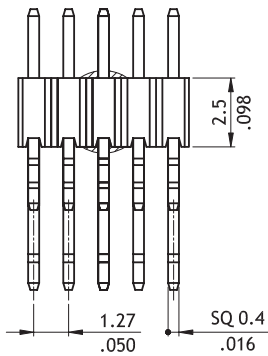

Recommended P.C. Board Layout

Ordering Code	①	②	③	④	⑤	⑥	⑦	⑧
	CH60	24	2	S	B	04	R0	NH

① Series No.  
 ② No. of Circuits: 4 ~24  
 ③ Plating Code: 2 = Gold flash over Nickel  
 ④ S = Right angle SMT Type  
 ⑤ Insulator : B = LCP  
 ⑥ Pin Length Option code :  
 ⑦ T0 = Tape & Reel Packing  
 ⑧ NH = For Lead Free IR process and Halogen- Free

**CH11 Series 2.00mm(.079") Single Row Pin Headers**

☉ Mate with CB22 series

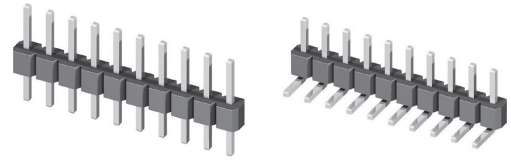

A = 2.0 x No. of Spaces  
 B = A + 2.0  
 Pin overall length 30.0mm max.

Option Code	Pin Dimension	
	C	D
00	3.9(.154)	2.8(.110)
01	6.8(.268)	3.0(.118)
02	9.0(.354)	2.0(.079)
03	8.0(.315)	3.0(.118)

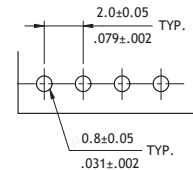
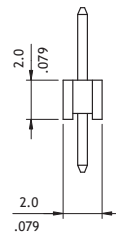
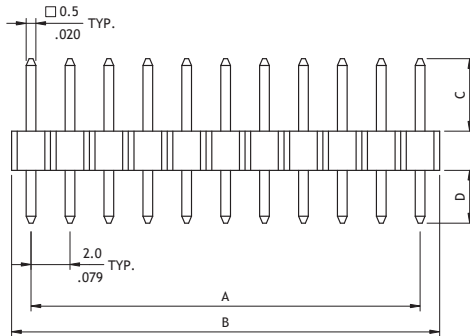

Recommended P.C. Board Layout

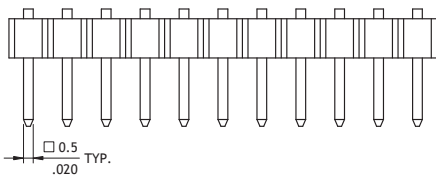

A = 2.0 x No. of Spaces  
 B = A + 2.0

Option Code	Pin Dimension		
	C	D	E
00	3.5(.138)	2.5(.098)	2.25(.089)

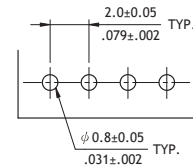
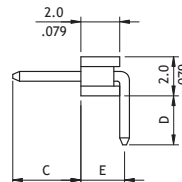
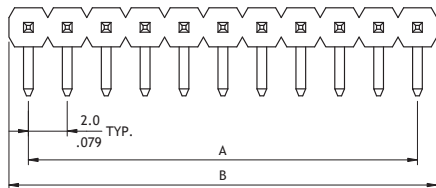

Recommended P.C. Board Layout

**Ordering Code**

① ② ③ ④ ⑤ ⑥ ⑦  
**CH11 40 2 V A 00 - NH**

- ① Series No.
- ② No. of Circuits: 02 ~ 40
- ③ Plating Code: 2 = Gold flash over Nickel
- ④ Tail & Mounting Style: V = Straight DIP Type  
 H = Right Angle DIP Type
- ⑤ Insulator Material & Color: A = Color Black
- ⑥ Other Options: 00 = Standard  
 \*See option code table  
 \*Consult manufacturer for customized pin length
- ⑦ NH = For Lead Free soldering process and Halogen- Free

# CH11 Series 2.00mm(.079") Single Row SMT Pin Headers

☉ Mate with CB22 series

RoHS Compliant

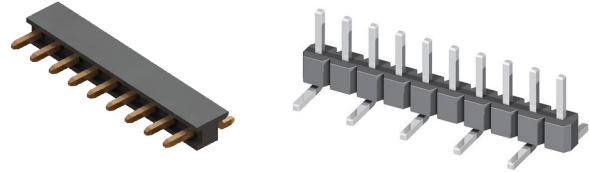

A = 2.0 x No. of Spaces  
B = A + 2.0

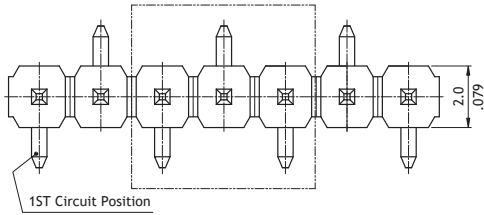

Option Code	Pin Dimension		
	C	D	F
00	4.0(.157)	2.77(.109)	4.6(.181)
01	6.73(.265)	2.77(.109)	4.6(.181)

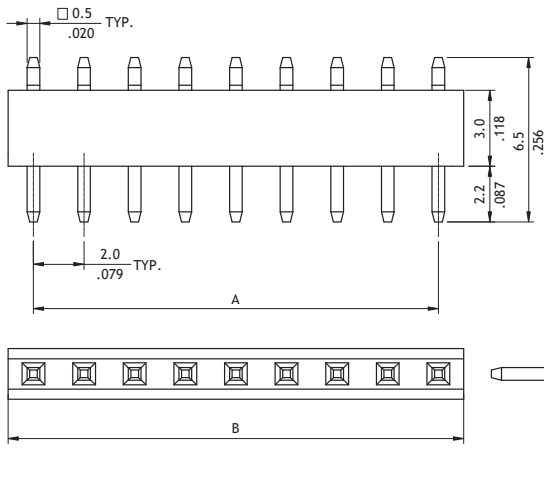
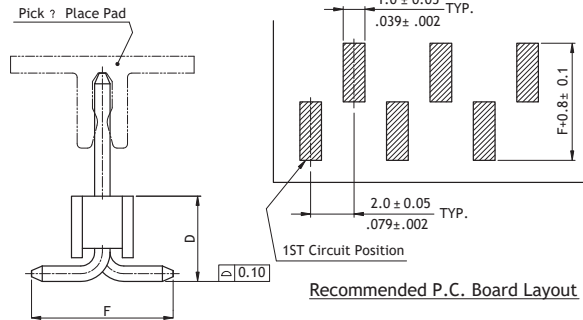
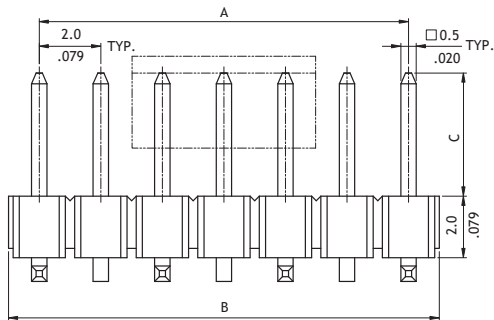

A = 2.0 x No. of Spaces  
B = A + 2.0

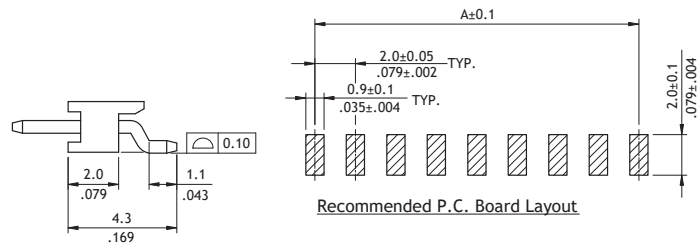

## Ordering Code

① ② ③ ④ ⑤ ⑥ ⑦ ⑧ ⑨  
**CH11 40 2 M 1 00 - 0 0 - NH**

- ① Series No.
- ② No. of Circuits: 02 ~ 40 (Top entry)  
02 ~ 12 (Side entry)
- ③ Plating Code: 2 = Gold flash over Nickel
- ④ Tail & Mounting Style: M = Top Entry SMT Type  
S = Side Entry SMT Type
- ⑤ Insulator Material & Color:  
1 = Color Black (for Top Entry)  
A = Color Black (for Side Entry)
- ⑥ Other Options: 00 = Standard (for Top Entry)  
01 = Standard (for Side Entry)  
\*See option code table  
\*Consult manufacturer for customized pin length
- ⑦ Pin Size: 0 = Original design
- ⑧ Packing Options: 0 = Without Pick & Place Pad (Tube)  
P = With Pick & Place Pad (Tape & Reel)  
\*Code 7 and 8 for Top Entry Type only
- ⑨ NH = For Lead Free IR process and Halogen- Free

**CH21 Series 2.00mm(.079") Single Row Dual Bodies Pin Headers**

☉ Mate with CB22 series

RoHS Compliant 

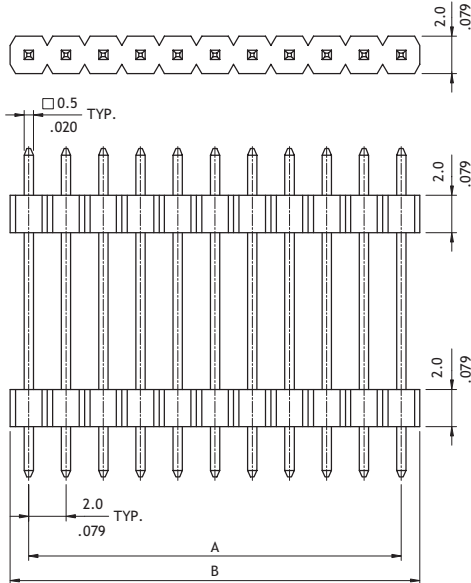
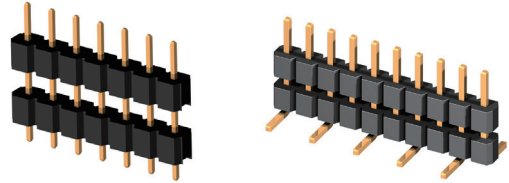

A = 2.0 x No. of Spaces  
 B = A + 2.0  
 Pin overall length 30.0mm max.

Option Code	Pin Dimension		
	C	D	E
00	4.0(.157)	2.5(.098)	11.6(.457)
01	3.55(.140)	2.55(.100)	9.55(.376)

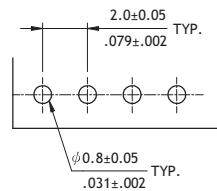

Recommended P.C. Board Layout

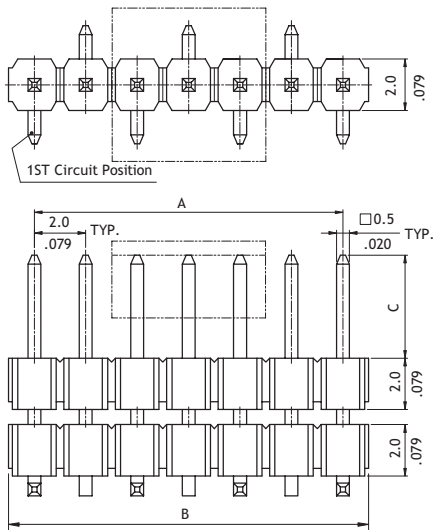

A = 2.0 x No. of Spaces  
 B = A + 2.0

Option Code	Pin Dimension			
	C	D	E	F
00	4.0(.157)	0.77(.030)	4.0(.157)	4.6(.181)
01	2.5(.098)	0.75(.029)	10.0(.394)	4.6(.181)

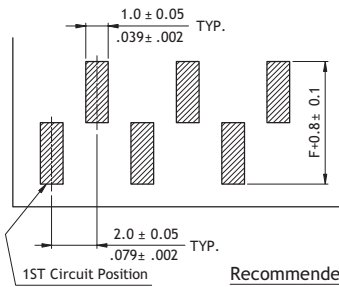

Recommended P.C. Board Layout

**Ordering Code**

① ② ③ ④ ⑤ ⑥ ⑦ ⑧  
**CH21 40 2 V 1 00 - 00 - NH**

- ① Series No.
- ② No. of Circuits: 02 ~ 40
- ③ Plating Code: 2 = Gold flash over Nickel
- ④ Tail & Mounting Style: V = Top Entry DIP Type  
 M = Top Entry SMT Type
- ⑤ Insulator Material & Color:  
 1 = Color Black (SMT)  
 A = Color Black (DIP)
- ⑥ Other Options: 00 = Standard  
 \*See option code table  
 \*Consult manufacturer for customized pin length
- ⑦ Packing Options:  
 00 = Without Pick & Place Pad (Tube)  
 0P = With Pick & Place Pad (Tape & Reel)  
 \*Code 7 for SMT Type only
- ⑧ NH = For Lead Free soldering process and Halogen- Free

## CH70 Series 2.00mm(.079") Straight SMT Dual Row Shrouded Pin Headers

☉ Mate with CA11 series Flat Cable-IDC Socket

RoHS Compliant

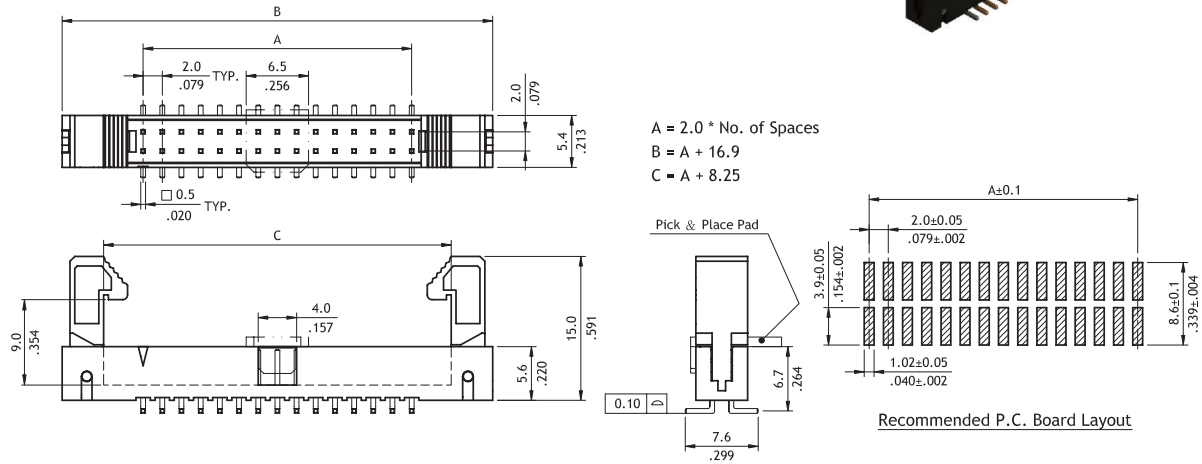
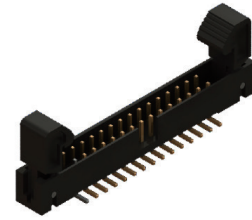

### Ordering Code

① ② ③ ④ ⑤ ⑥  
**CH70 50 D M 1 Y0**

- ① Series No.
- ② No. of Circuits:  
Without Pad: 08 ~ 50  
With Pad: 10 ~ 50
- ③ Plating Code:  
D = Selective 10μ" Gold flash over Nickel
- ④ Tail Style: M = SMT Type
- ⑤ Color: 1 = Black
- ⑥ Other Options:  
Y0 = Tray Packing (With Pad)  
R0 = Tape & Reel (With Pad)

RoHS Compliant

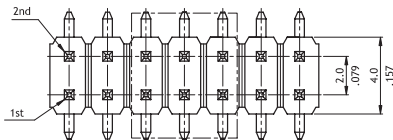

$A = 2.0 \times \text{No. of Spaces}$   
 $B = A + 2.0$

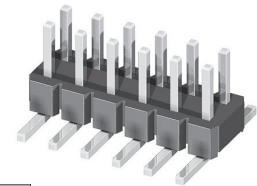

Option Code	Pin Dimension		
	C	D	F
00	4.0(.157)	2.77(.109)	6.5(.256)
01	6.0(.236)	2.77(.109)	6.5(.256)

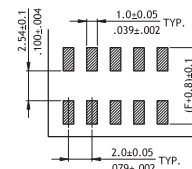
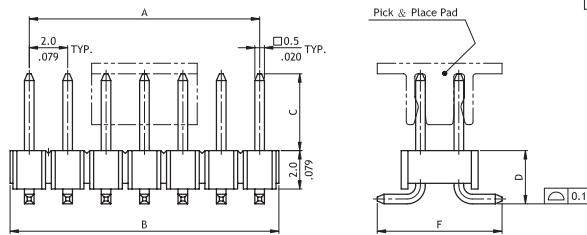

Recommended P.C. Board Layout

### Ordering Code

① ② ③ ④ ⑤ ⑥ ⑦ ⑧ ⑨  
**CH71 80 2 M 1 00 - 0 0 - NH**

- ① Series No.
- ② No. of Circuits: 04 ~ 80
- ③ Plating Code: 2 = Gold flash over Nickel
- ④ Tail & Mounting Style: M = Top Entry SMT Type
- ⑤ Insulator Material & Color:  
1 = Color Black
- ⑥ Other Options: 00 = Standard  
\*See option code table  
\*Consult manufacturer for customized pin length
- ⑦ Pin Size: 0 = Original design
- ⑧ Packing: 0 = Without Pick & Place Pad (Tube)  
P = With Pick & Place Pad (Tape & Reel)  
\*Code 7 and 8 for Top Entry Type only
- ⑨ NH = For Lead Free IR process and Halogen- Free

**CH71 Series 2.00mm(.079") Dual Row Pin Headers**

- ⊙ With standoff prevent flux wicking
- ⊙ Mate with CB74, CB76 and CB78 series

RoHS Compliant 

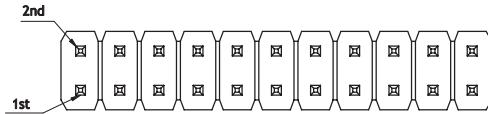
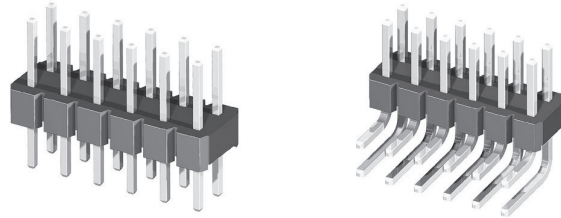

A = 2.0 x No. of Spaces  
 B = A + 2.0  
 Pin overall length 30.0mm max.

Option Code	Pin Dimension	
	C	D
00	3.9(.154)	2.8(.110)
01	6.8(.268)	3.0(.118)

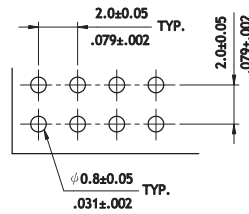
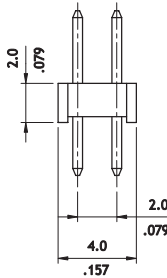
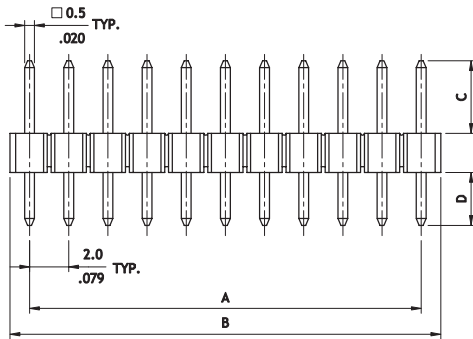

Recommended P.C. Board Layout

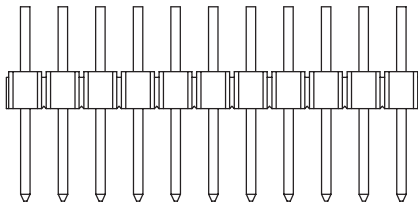

A = 2.0 x No. of Spaces  
 B = A + 2.0

Option Code	Pin Dimension		
	C	D	E
00	3.9(.154)	2.8(.110)	1.1(.043)
02	2.9(.114)	2.8(.110)	1.1(.043)

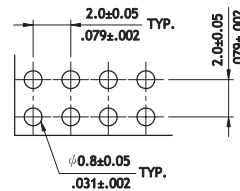
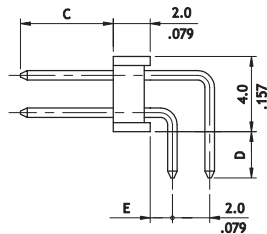
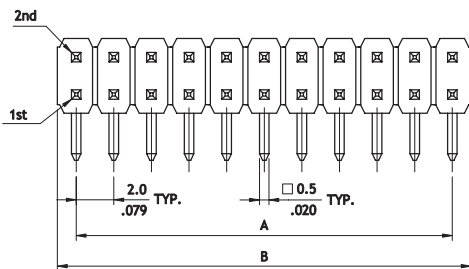

Recommended P.C. Board Layout

**Ordering Code**

① ② ③ ④ ⑤ ⑥ ⑦  
**CH71 80 2 V A 00 - NH**

- ① Series No.
- ② No. of Circuits: 02 ~ 80
- ③ Plating Code : 2 = Gold flash over Nickel
- ④ Tail : V = Straight DIP Type  
 H = Right Angle DIP Type

- ⑤ Insulator Material & Color:  
 A = Color Black
- ⑥ Other Options: 00 = Standard  
 \*See option code table  
 \*Consult manufacturer for customized pin length
- ⑦ NH = For Lead Free soldering process and Halogen-Free

# CH72 Series 2.00mm(.079") Dual Row Pin Headers

☉ Mate with CB74, CB78 series

RoHS Compliant

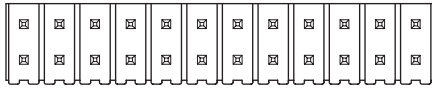
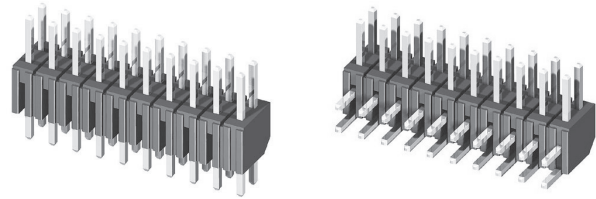

A = 2.0 \* No. of Spaces  
B = A + 2.0

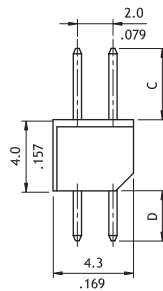
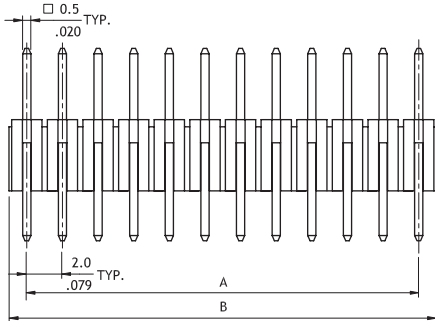

Option Code	Pin Dimension	
	C	D
00	4.0(.157)	2.8(.110)

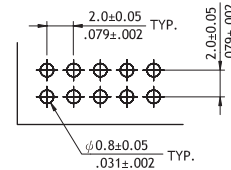

Recommended P.C. Board Layout

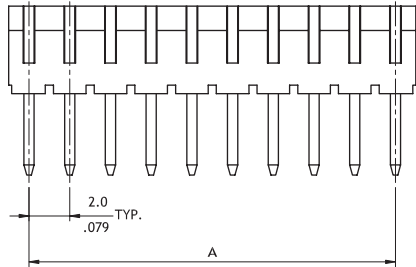

A = 2.0 \* No. of Spaces  
B = A + 2.00

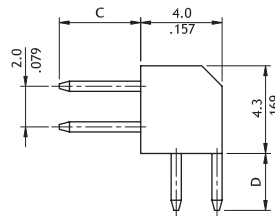
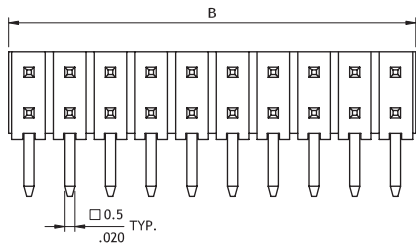

Option Code	Pin Dimension	
	C	D
00	4.0(.157)	2.8(.110)

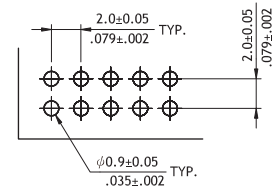

Recommended P.C. Board Layout

## Ordering Code

① ② ③ ④ ⑤ ⑥ ⑦ ⑧  
**CH72 50 2 V 1 00 - R0 - NH**

- ① Series No.
- ② No. of Circuits: 08 ~50
- ③ Plating Code : 2 = Gold flash over Nickel
- ④ Tail : V = Straight DIP Type  
H = Right Angle DIP Type

- ⑤ Color: 1 = Black
- ⑥ Other Options : 00 = Standard  
\*See option code table
- ⑦ R0 = Reel Packing
- ⑧ NH = For Lead Free IR process and Halogen- Free

CH74 Series 2.00mm(.079") Dual Row Box Headers

☉ Mate with CA11 series

RoHS Compliant 

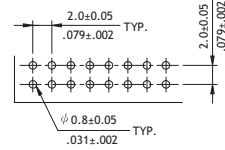
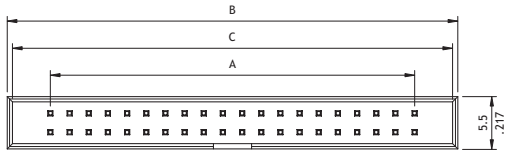
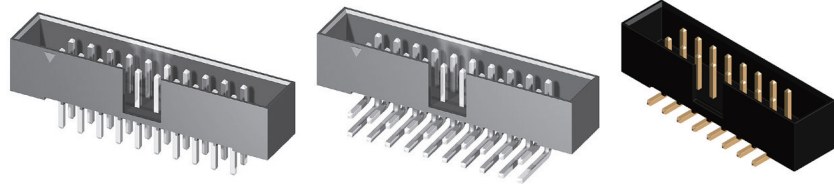

Recommended P.C. Board Layout

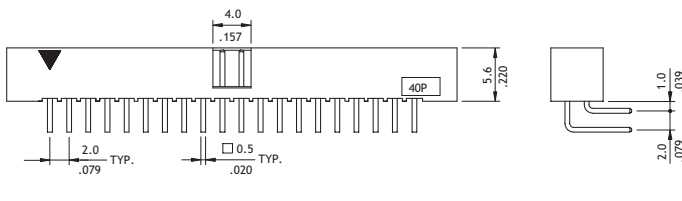
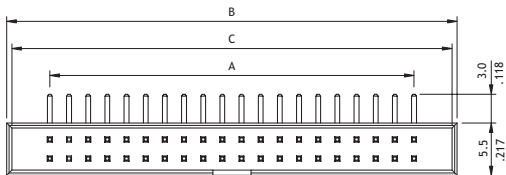
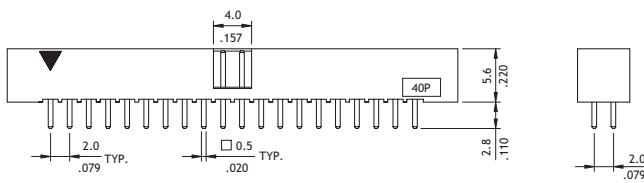

Circuits	Dimension		
	A	B	C
6	4.0(.157)	13.2(.520)	12.1(.476)
8	6.0(.236)	15.2(.598)	14.1(.555)
10	8.0(.315)	17.2(.677)	16.1(.634)
12	10.0(.394)	19.2(.756)	18.1(.713)
14	12.0(.472)	21.2(.835)	20.1(.791)
16	14.0(.551)	23.2(.913)	22.1(.870)
18	16.0(.630)	25.2(.992)	24.1(.949)
20	18.0(.709)	27.2(1.071)	26.1(1.028)
22	20.0(.787)	29.2(1.150)	28.1(1.106)
24	22.0(.866)	31.2(1.228)	30.1(1.185)
26	24.0(.945)	33.2(1.307)	32.1(1.264)
28	26.0(1.024)	35.2(1.386)	34.1(1.343)
30	28.0(1.102)	37.2(1.465)	36.1(1.421)
32	30.0(1.181)	39.2(1.543)	38.1(1.500)
34	32.0(1.260)	41.2(1.622)	40.1(1.579)
36	34.0(1.339)	43.2(1.701)	42.1(1.657)
40	38.0(1.496)	47.2(1.858)	46.1(1.815)
44	42.0(1.654)	51.2(2.016)	50.1(1.972)
50	48.0(1.890)	57.2(2.252)	56.1(2.209)
60	58.0(2.283)	67.2(2.646)	66.1(2.602)
64	62.0(2.441)	71.2(2.803)	70.1(2.760)
68	66.0(2.598)	75.2(2.961)	74.1(2.917)

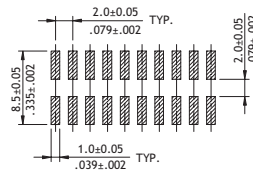
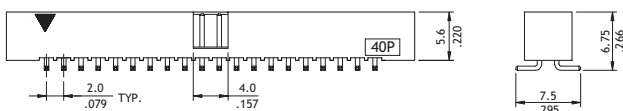
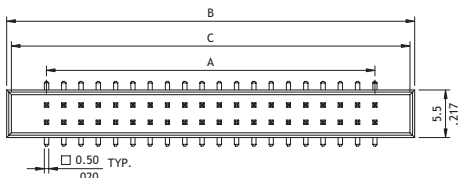

Recommended P.C. Board Layout

Ordering Code

① CH ② 74 ③ 68 ④ 2 ⑤ V ⑥ 1 ⑦ 00 - NH

- ① Series No.
- ② No. of Circuits: 06 ~ 68
- ③ Plating Code : 2 = Gold flash over Nickel

- ④ Tail : V = Straight DIP Type  
H = Right Angle DIP Type  
M = SMT Type
- ⑤ Color: 1 = Black
- ⑥ Other Options: 00 = Standard  
\*See option code table
- ⑦ NH = For Lead Free soldering process and Halogen- Free

# CH75 Series 2.00mm(.079") Dual Row Dual Bodies Pin Headers

☉ Mate with CB74 and CB78 series

RoHS Compliant

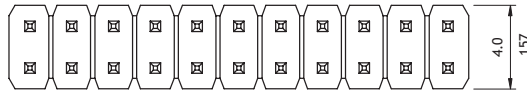
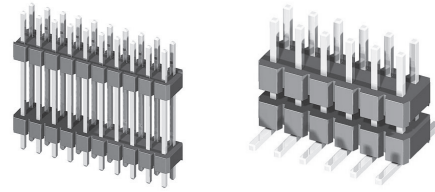

A = 2.0 x No. of Spaces  
B = A + 2.0  
Pin overall length 30.0mm max.

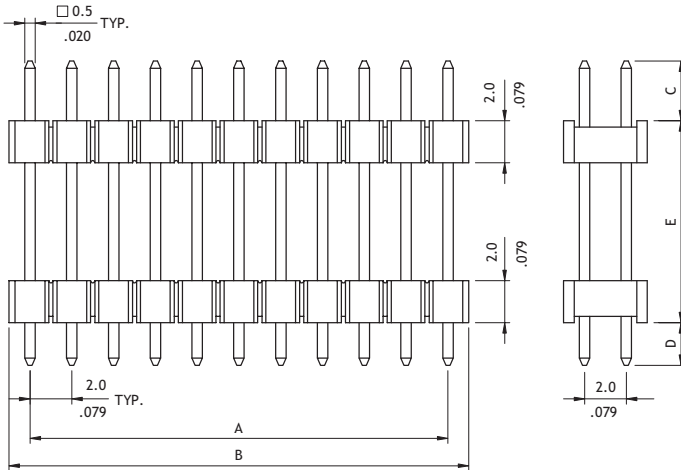

Option Code	Pin Dimension		
	C	D	E
00	4.0(.157)	2.50(.098)	11.60(.457)
01	3.55(.140)	2.55(.100)	9.55(.376)
02	4.0(.157)	2.50(.098)	9.30(.366)

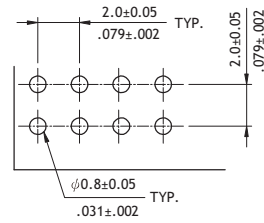

Recommended P.C. Board Layout

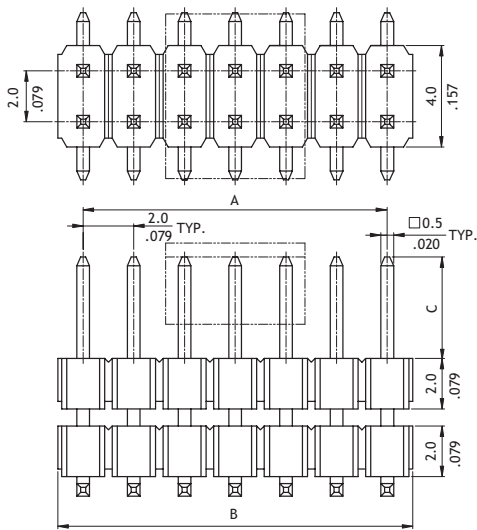

A = 2.0 x No. of Spaces  
B = A + 2.0

Option Code	Pin Dimension			
	C	D	E	F
00	4.0(.157)	0.77(.030)	4.00(.157)	6.50(.256)
01	4.0(.157)	0.77(.030)	11.00(.433)	6.50(.256)
02	4.0(.157)	0.77(.030)	8.00(.315)	6.50(.256)

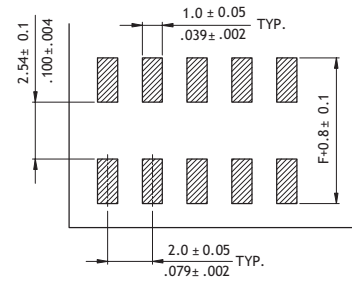
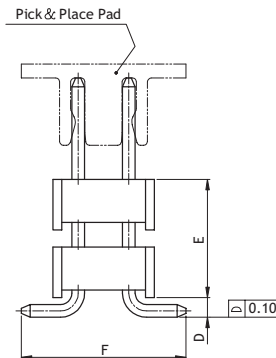

Recommended P.C. Board Layout

## Ordering Code

① ② ③ ④ ⑤ ⑥ ⑦ ⑧  
**CH75 80 2 M 1 00-00-NH**

- ① Series No.
- ② No. of Circuits: 04 ~ 80
- ③ Plating Code: 2 = Gold flash over Nickel
- ④ Tail & Mounting Style:  
 V = Straight DIP Type  
 M = Straight SMT Type
- ⑤ Insulator Color:  
 1 = Color Black (SMT)  
 A = Color Black (DIP)
- ⑥ Other Options: 00 = Standard  
 \*See option code table  
 \*Consult manufacturer for customized pin length
- ⑦ Packing Options:  
 00 = Without Pick & Place Pad (Tube)  
 0P = With Pick & Place Pad (Tape & Reel)  
 \*Code 7 for SMT Type only
- ⑧ NH = For Lead Free soldering process and Halogen- Free

CH79 Series 2.00mm (.079") Dual Row Pin Headers

☉ With polarizing slot

RoHS Compliant

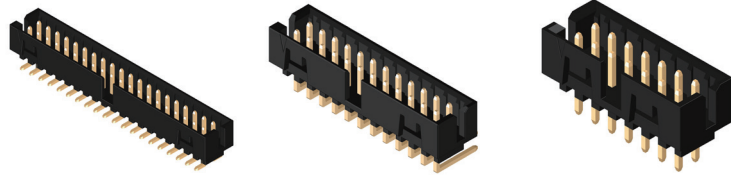

P/N: CH79\*\*\*V1C0

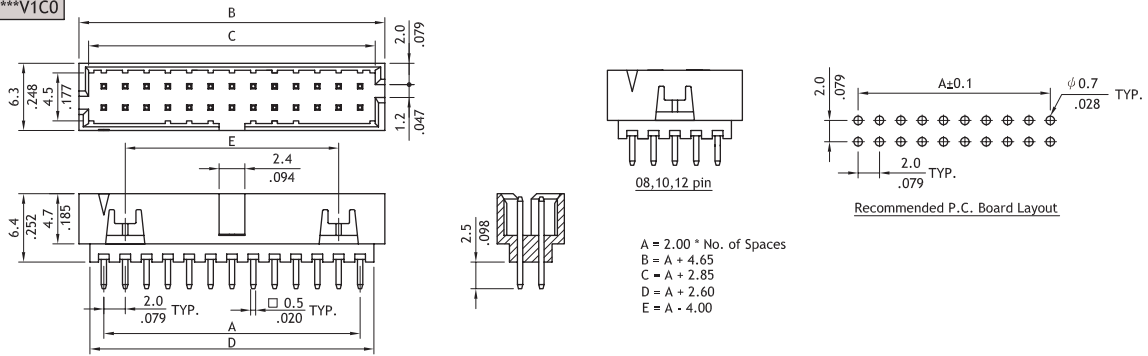

P/N: CH79\*\*\*H1C0

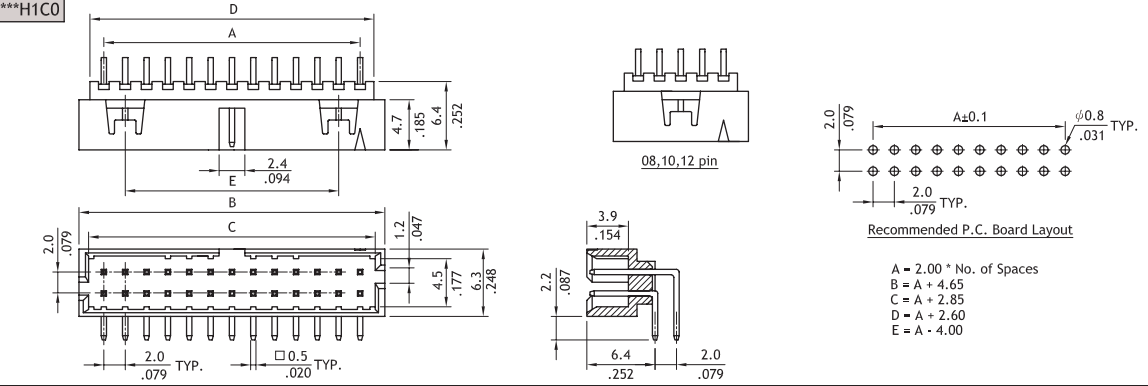

P/N: CH79\*\*\*M1C\*

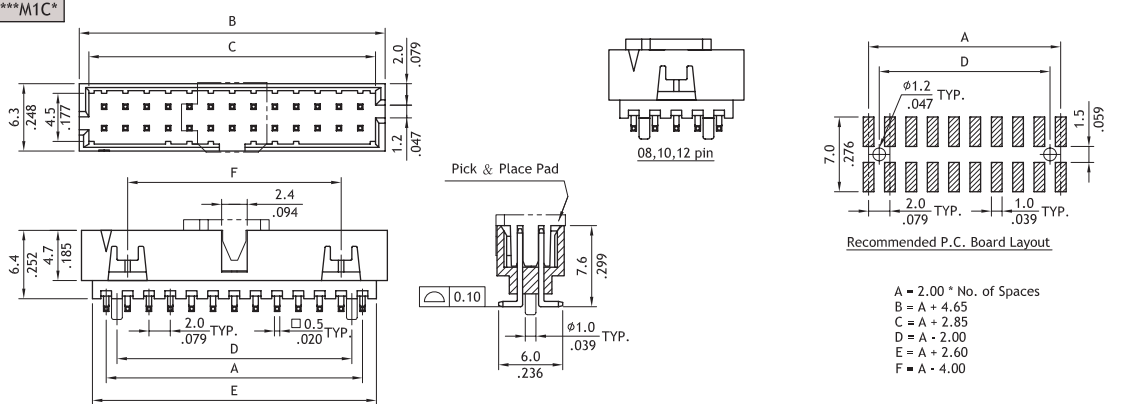

Ordering Code

① ② ③ ④ ⑤ ⑥ ⑦  
**CH79 08 2 V 1 C0 - NH**

- ① Series No.
- ② No. of Circuits: 08 ~ 50
- ③ Plating Code:  
 1 = Matte Tin over Nickel  
 2 = Gold flash over Nickel

- ④ Tail Style:  
 V = Straight DIP Type  
 H = Right Angle DIP Type  
 M = Straight SMT Type
- ⑤ Color : 1=Black

- ⑥ Other Options:  
 C0 = With center Polarization&Locks, without Peg(DIP)  
 C0 = With center Polarization&Locks, with Peg(SMT)  
 CP = With center Polarization&Locks, without Peg(SMT)
- ⑦ NH = For Lead Free soldering process and Halogen- Free

## CH79 Series 2.00mm(.079") Dual Row Box Pin Headers

☉ Shrouded header with eject latch

**RoHS** Compliant

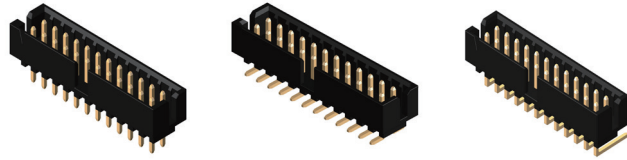

P/N: CH79\*\*\*V1D0

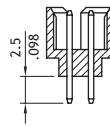
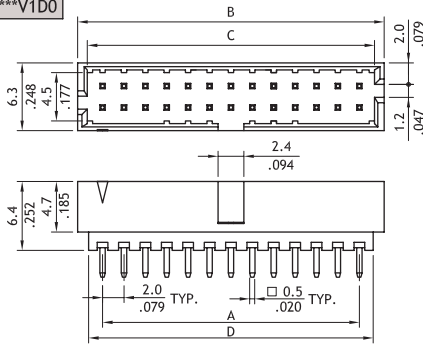

A = 2.00 \* No. of Spaces  
 B = A + 4.65  
 C = A + 2.85  
 D = A + 2.60

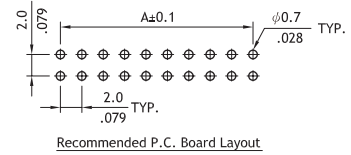

P/N: CH79\*\*\*H1D0

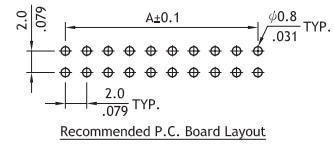
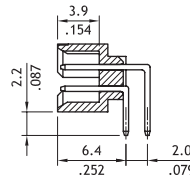
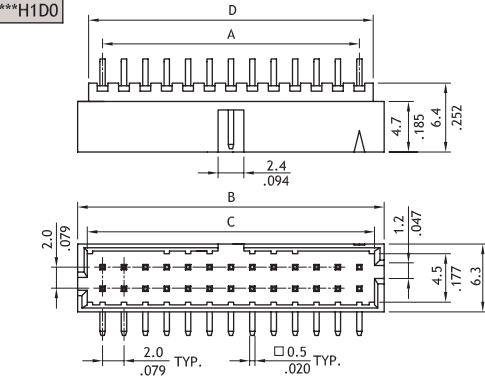

A = 2.00 \* No. of Spaces  
 B = A + 4.65  
 C = A + 2.85  
 D = A + 2.60

P/N: CH79\*\*\*M1D\*

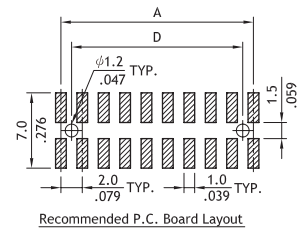
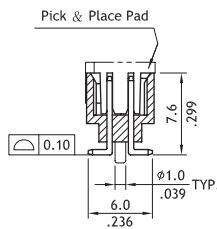
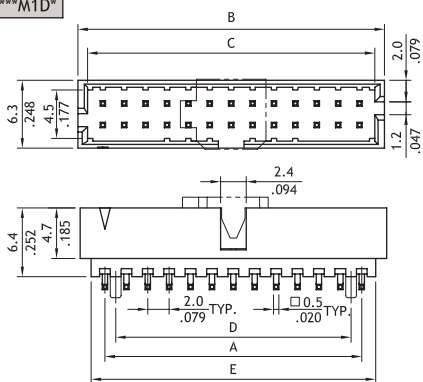

A = 2.00 \* No. of Spaces  
 B = A + 4.65  
 C = A + 2.85  
 D = A + 2.00  
 E = A + 2.60

### Ordering Code

① ② ③ ④ ⑤ ⑥  
**CH79 08 2 V 1 D0**

① Series No.

② No. of Circuits: 08 ~ 50

③ Plating Code:

- 1 = Matte Tin over Nickel
- 2 = Gold flash over Nickel

④ Tail Style:

- M = Straight SMT Type
- V = Straight DIP Type
- H = Right Angle DIP Type

⑤ Color: 1 = Black

⑥ Pin Length options:

D0 = With center Polarization, without Peg(DIP)

D0 = With center Polarization, with Peg(SMT)

DP = With center Polarization, without Peg(SMT)

**CH34 Series 2.54mm(.100") Single Row Dual Bodies Pin Headers**

© Mate with CB33, CB37 and CB39 series

RoHS Compliant

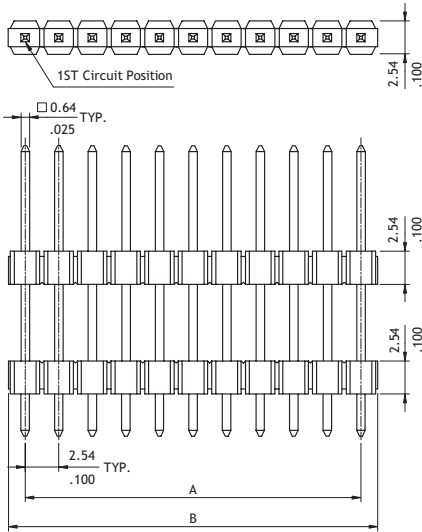
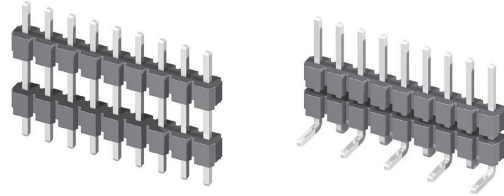

A = 2.54 x No. of Spaces  
B = A + 2.36  
Pin overall length 30.0mm max.

Option Code	Pin Dimension		
	C	D	E
00	10.30(.406)	3.20(.126)	12.00(.472)
01	3.15(.124)	3.15(.124)	9.00(.354)
02	3.40(.134)	3.00(.118)	9.60(.378)
03	7.00(.276)	3.00(.118)	18.00(.709)
04	3.00(.118)	3.00(.118)	6.00(.236)

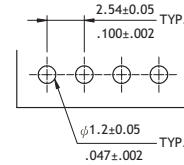

Recommended P.C. Board Layout

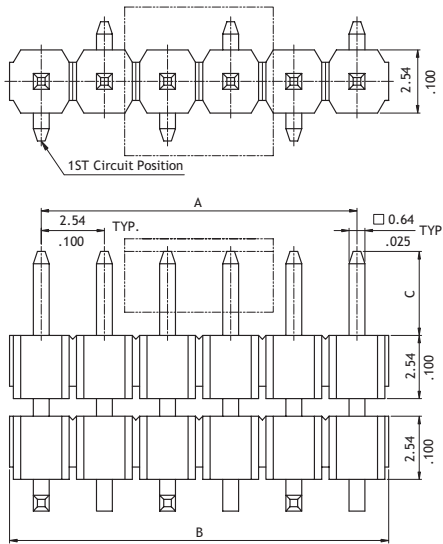

A = 2.54 x No. of Spaces  
B = A + 2.36

Option Code	Pin Dimension			
	C	D	E	F
00	6.0(.236)	1.27(.050)	5.08(.200)	4.8(.189)
01	2.81(.111)	1.27(.050)	7.73(.304)	4.8(.189)

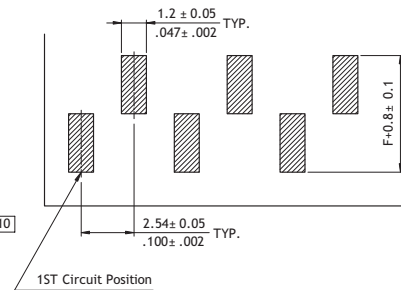

Recommended P.C. Board Layout

**Ordering Code**

① ② ③ ④ ⑤ ⑥ ⑦ ⑧  
**CH34 40 2 M 1 00 - 00 - NH**

- ① Series No.
- ② No. of Circuits: 02 ~ 40
- ③ Plating Code: 2 = Gold flash over Nickel
- ④ Tail & Mounting Style:  
 V = Straight DIP Type  
 M = Straight SMT Type
- ⑤ Insulator Color:  
 1 = Color Black (SMT)  
 A = Color Black (DIP)
- ⑥ Other Options: 00 = Standard  
 \*See option code table  
 \*Consult manufacturer for customized pin length
- ⑦ Packing Options:  
 00 = Without Pick & Place Pad (Tube)  
 0P = With Pick & Place Pad (Tape & Reel)  
 \*Code 7 for SMT Type only
- ⑧ NH = For Lead Free soldering process and Halogen- Free

## CH31 Series 2.54mm(.100") Single Row Pin Headers

☉ Mate with CB33 , CB37 and CB39 series

RoHS Compliant

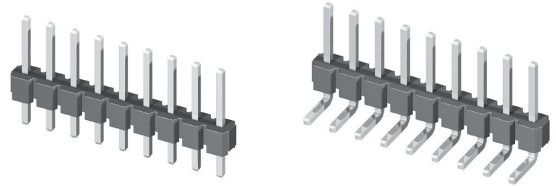

P/N CH31\*\*2VA00-NH



A = 2.54 x No. of Spaces  
B = A + 2.36  
Pin overall length 30.0mm max.

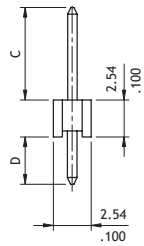
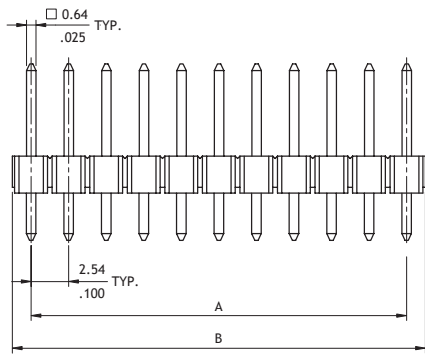

Option Code	Pin Dimension	
	C	D
00	6.0(.236)	3.00(.118)
01	6.26(.246)	3.00(.118)
02	5.86(.231)	3.00(.118)
03	8.86(.349)	3.00(.118)

P/N CH31\*\*2HA00-NH

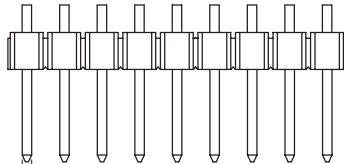

A = 2.54 x No. of Spaces  
B = A + 2.36  
Pin overall length 30.0mm max.

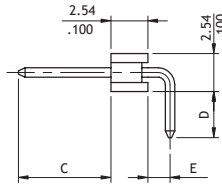
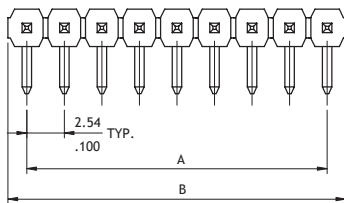

Option Code	Pin Dimension		
	C	D	E
00	6.0(.236)	3.00(.118)	1.5(.059)
01	6.26(.246)	3.00(.118)	1.5(.059)
02	5.86(.231)	3.00(.118)	1.5(.059)
03	8.30(.327)	3.00(.118)	1.5(.059)
04	7.26(.286)	3.00(.118)	1.5(.059)

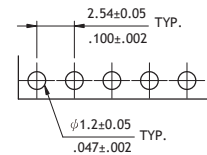

Recommended P.C. Board Layout

### Ordering Code

① ② ③ ④ ⑤ ⑥ ⑦  
CH31 40 2 V A 00 - NH

- ① Series No.
- ② No. of Circuits: 01 ~ 40
- ③ Plating Code:  
2 = Gold flash over Nickel  
B = Selective 15µ" Gold flash over Nickel
- ④ Tail & Mounting Style:  
V = Straight DIP Type  
H = Right Angle DIP Type
- ⑤ Insulator Material & Color : A = Color Black
- ⑥ Other Options: 00 = Standard  
\*See option code table  
\*Consult manufacturer for customized pin length
- ⑦ NH = For Lead Free soldering process and Halogen- Free

**CH31 Series 2.54mm(.100") Single Row SMT Pin Headers**

☉ Mate with CB33, CB37 and CB39 series

RoHS Compliant

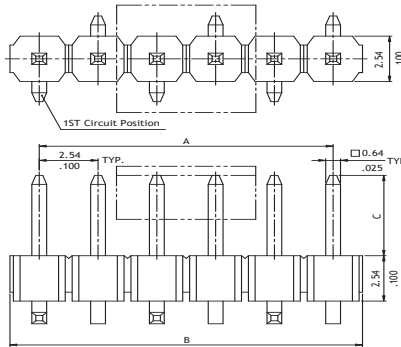
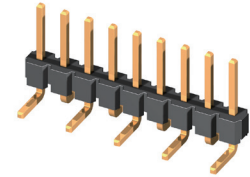

A = 2.54x No. of Spaces  
B = A + 2.36  
Pin overall length 30.0mm max.

Option Code	Pin Dimension		
	C	D	F
00	6.0(.236)	3.81(.150)	4.8(.189)
01	3.5(.138)	7.80(.307)	4.8(.189)

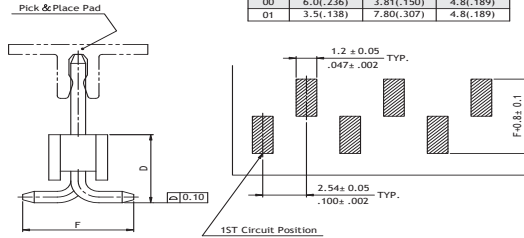

Recommended P.C. Board Layout

**Ordering Code**

① ② ③ ④ ⑤ ⑥ ⑦ ⑧  
**CH31 40 2 M 1 00 - 00 - NH**

- ① Series No.
- ② No. of Circuits: 02 ~ 20
- ③ Plating Code : 2 = Gold flash over Nickel
- ④ Tail Style: M = SMT Type
- ⑤ Insulator Material & Color:  
1 = Color Black

- ⑥ Other Options: 00 = Standard  
\*See option consult manufacturer  
\*Consult manufacturer for customized pin length
- ⑦ Packing Options: 00 = Without Pick & Place Pad(Tube)  
OP = With Pick & Place Pad(Tape & Reel)
- ⑧ NH = For Lead Free IR process and Halogen- Free

**CH81 Series 2.54mm(.100") Dual Row SMT Pin Headers**

☉ Mate with CB33, CB37 and CB39 series

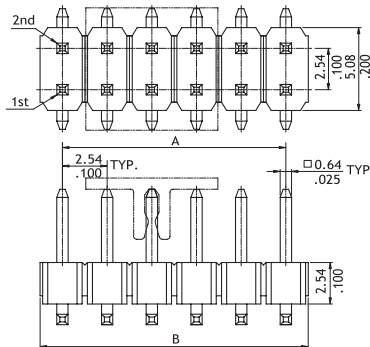
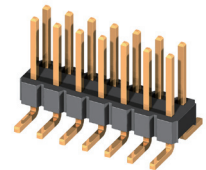

A = 2.54x No. of Spaces  
B = A + 2.36

Option Code	Pin Dimension		
	C	D	E
00	8.80(.346)	3.4(.134)	7.4(.291)
01	6.0(.236)	3.4(.134)	7.4(.291)
02	6.0(.236)	3.81(.150)	7.4(.291)

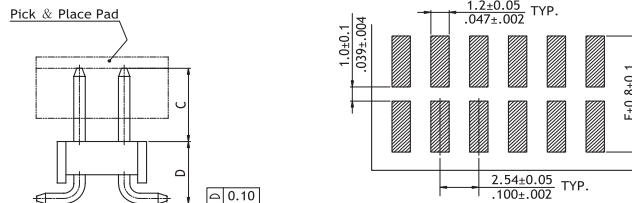

Recommended PCB Layout

**Ordering Code**

① ② ③ ④ ⑤ ⑥ ⑦ ⑧  
**CH81 80 2 M 1 00 - 00 - NH**

- ① Series No.
- ② No. of Circuits: 04 ~ 80
- ③ Plating Code: 2 = Gold flash over Nickel
- ④ Tail Style: M= Straight SMT Type
- ⑤ Insulator Material & Color:  
1 = Color Black

- ⑥ Other Options: 00 = Standard  
\*See option code table  
\*Consult manufacturer for customized pin length
- ⑦ Packing Options: 00 = Without Pick & Place Pad (Tube)  
OP = With Pick & Place Pad (Tape & Reel)
- ⑧ NH = For Lead Free IR process and Halogen- Free

## CH81 Series 2.54mm(.100") Dual Row DIP Pin Headers

☉ Mate with CB83, CB85, CB87, CB91, CB96 and CB97 series

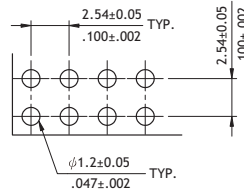
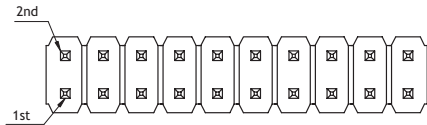
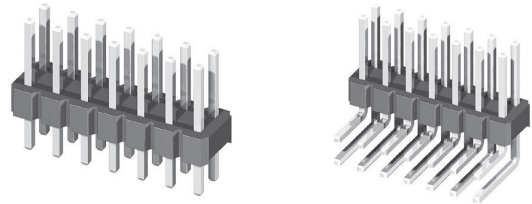

A = 2.54 x No. of Spaces  
B = A + 2.36  
Pin overall length 30.0mm max.

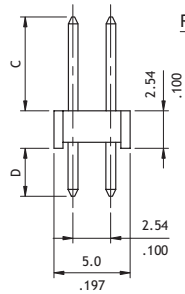
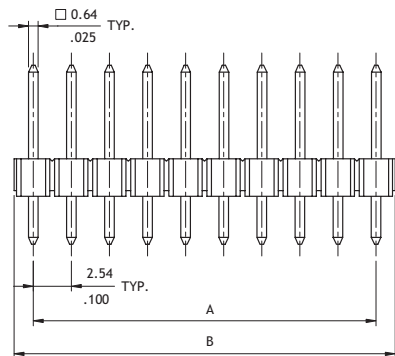

Option Code	Pin Dimension	
	C	D
00	6.00(.236)	3.00(.118)
01	6.26(.246)	3.00(.118)
02	3.50(.138)	3.50(.138)
03	4.20(.165)	4.20(.165)
04	15.50(.610)	3.00(.118)

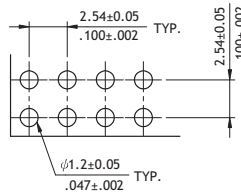
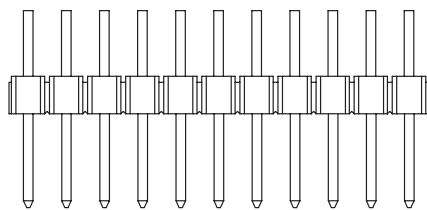

A = 2.54 x No. of Spaces  
B = A + 2.36

Recommended P.C. Board Layout

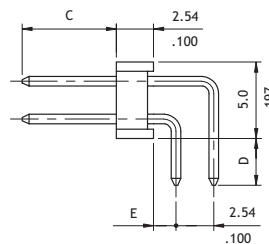
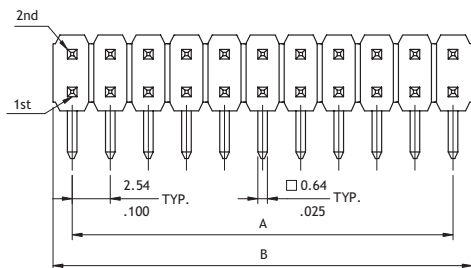

Option Code	Pin Dimension		
	C	D	E
00	6.00(.236)	3.00(.118)	1.50(.059)
01	6.26(.246)	3.00(.118)	1.50(.059)
02	3.50(.138)	3.50(.138)	1.50(.059)
03	3.00(.118)	3.00(.118)	1.50(.059)
04	3.40(.134)	2.80(.110)	1.50(.059)

### Ordering Code

① ② ③ ④ ⑤ ⑥ ⑦  
CH81 80 2 V A 00 - NH

- ① Series No.
- ② No. of Circuits: 04 ~ 80
- ③ Plating Code : 2 = Gold flash over Nickel
- ④ Tail: V = Straight DIP Type  
H = Right Angle DIP Type

- ⑤ Insulator Material & Color:  
A = Color Black
- ⑥ Other Options: 00 = Standard  
\*See option code table  
\*Consult manufacturer for customized pin length
- ⑦ NH = For Lead Free soldering process and Halogen- Free



## CH87 Series 2.54mm(.100") Box Headers

- ⊙ With polarizing slot
- ⊙ Mate with CB94,CA21 series

RoHS Compliant

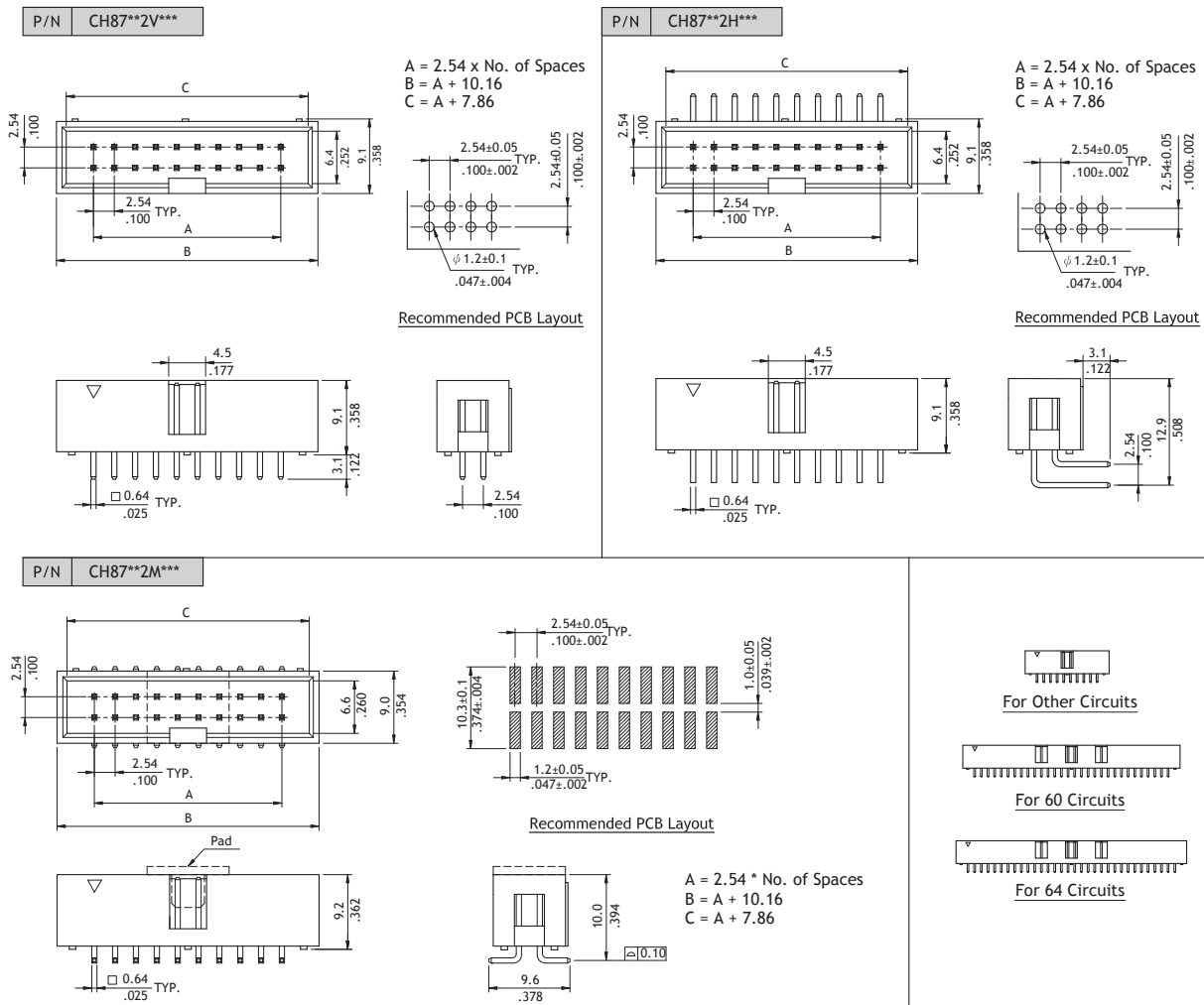
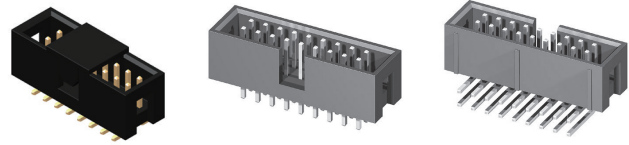

### Ordering Code

① CH ② 87 ③ 64 ④ 2 ⑤ V ⑥ 1 00

- ① Series No.
- ② No. of Circuits:  
(Available: 06,08,10,12,14,16, 20,24,26,30,34,44,50, 60,64)  
\*Circuits not found above please consult manufacturer

- ③ Plating Code:  
2 = Gold flash over Nickel
- ④ Tail & Mounting Style:  
V = Straight DIP Type  
H = Right Angle DIP Type  
M = Straight SMT Type

- ⑤ Insulator Material & Color:  
1 = Color Black (SMT)  
A = Color Black (DIP)
- ⑥ Other Options:  
00 = Standard (DIP)  
00 = Without Pad (SMT)  
P0 = With Pad (SMT)  
\*Special options consult manufacturer

**CH88 Series 2.54mm(.100") Shrouded Box Headers**

- ⊙ Shrouded header with eject latch
- ⊙ Mate with CA21 series

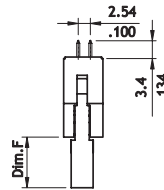
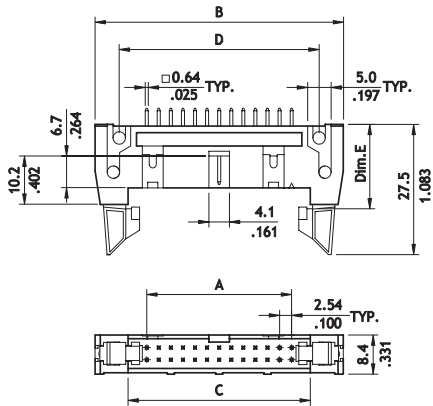
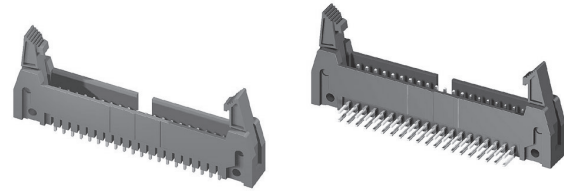

	Long	Short
Dim.E	22.0(.866)	18.4(.724)
Dim.F	10.9(.429)	10.8(.425)

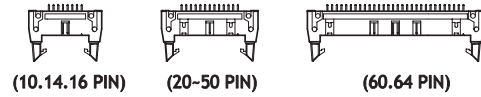

Circuits	Dimension			
	A	B	C	D
10	10.16(.400)	31.87(1.255)	17.90(.705)	21.70(.854)
14	15.24(.600)	36.95(1.454)	22.95(.903)	26.88(1.058)
16	17.78(.700)	39.48(1.554)	25.50(1.004)	29.27(1.152)
20	22.86(.900)	44.62(1.757)	30.58(1.204)	34.50(1.358)
24	27.94(1.100)	49.67(1.956)	35.70(1.406)	39.50(1.555)
26	30.48(1.200)	52.23(2.056)	38.25(1.506)	42.05(1.656)
30	35.56(1.400)	57.30(2.256)	43.35(1.707)	47.20(1.858)
34	40.64(1.600)	62.38(2.456)	48.40(1.906)	52.15(2.053)
40	48.26(1.900)	69.95(2.754)	56.05(2.207)	59.90(2.358)
50	60.96(2.400)	82.70(3.255)	68.70(2.705)	72.55(2.856)
60	73.66(2.900)	95.45(3.758)	81.50(3.209)	85.25(3.356)
64	78.74(3.100)	100.60(3.960)	86.40(3.402)	90.35(3.557)

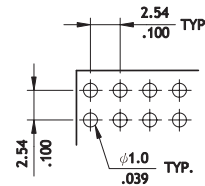
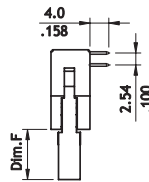
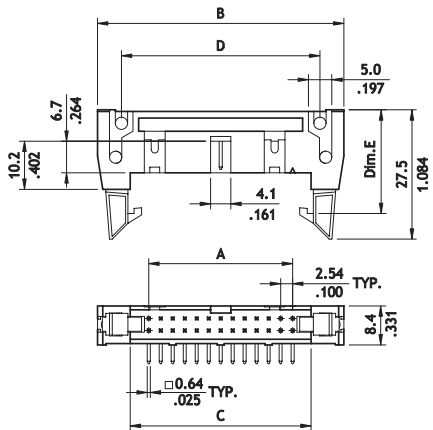

Recommended P.C. Board Layout

**Ordering Code**

① ② ③ ④ ⑤ ⑥  
**CH88 64 2 A 1 00-B**

- ① Series No.
- ② No. of Circuits: see above table please consult manufacturer
- ③ Plating Code: 2 = Gold flash over Nickel
- ④ Tail & Mounting Style:  
 A = With Long Latch / Straight (DIM.E = 22.0)  
 B = With Long Latch / Right Angle (DIM.E = 22.0)  
 C = With Short Latch / Straight (DIM.E = 18.4)  
 D = With Short Latch / Right Angle (DIM.E = 18.4)
- ⑤ Insulator Material & Color:  
 1 = Black
- ⑥ Other Options: 00-B= Standard  
 \*Special options consult manufacturer

## CS76 Series NGFF Connectors

- ⊙ Housing: High temperature thermo plastic UL 94V-0
- ⊙ Terminal: Copper Alloy
- ⊙ Solder Fixed TAB: Copper Alloy

RoHS Compliant

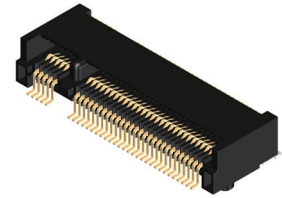

P/N: CS76672AB0-R0

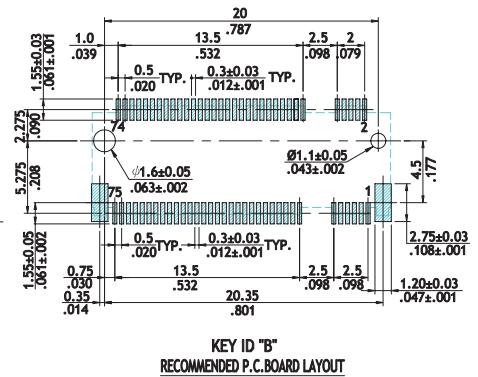
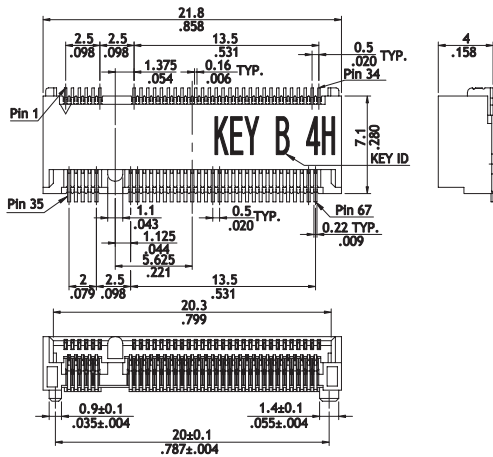

P/N: CS76672AM0-R0

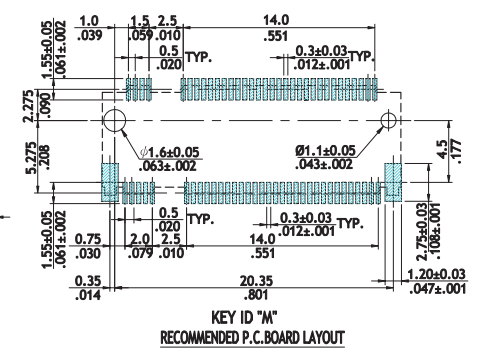
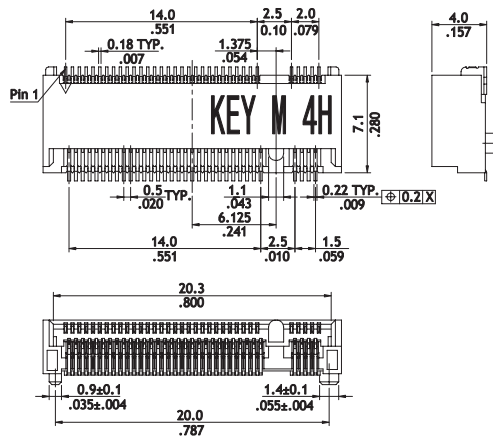

### Ordering Code

① ② ③ ④ ⑤ ⑥  
CS 7 6 6 7 2 A M 0 - R 0

- ① Series No.
- ② No. of Circuits: 67
- ③ Plating Code: 2 = Gold flash over Nickel
- ④ Height: A = 4.0mm
- ⑤ Key ID: M0 = Key M B0 = Key B
- ⑥ Packing Options: R0 = Tape & Reel

CS59 Series Mini PCI 4.0H 52pin Top Mount Connectors

- ⊙ Housing: High temperature thermo plastic UL 94V-0
- ⊙ Terminal: Copper Alloy
- ⊙ Solder Fixed TAB: Copper Alloy

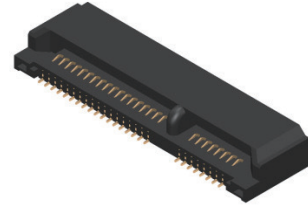

RoHS Compliant

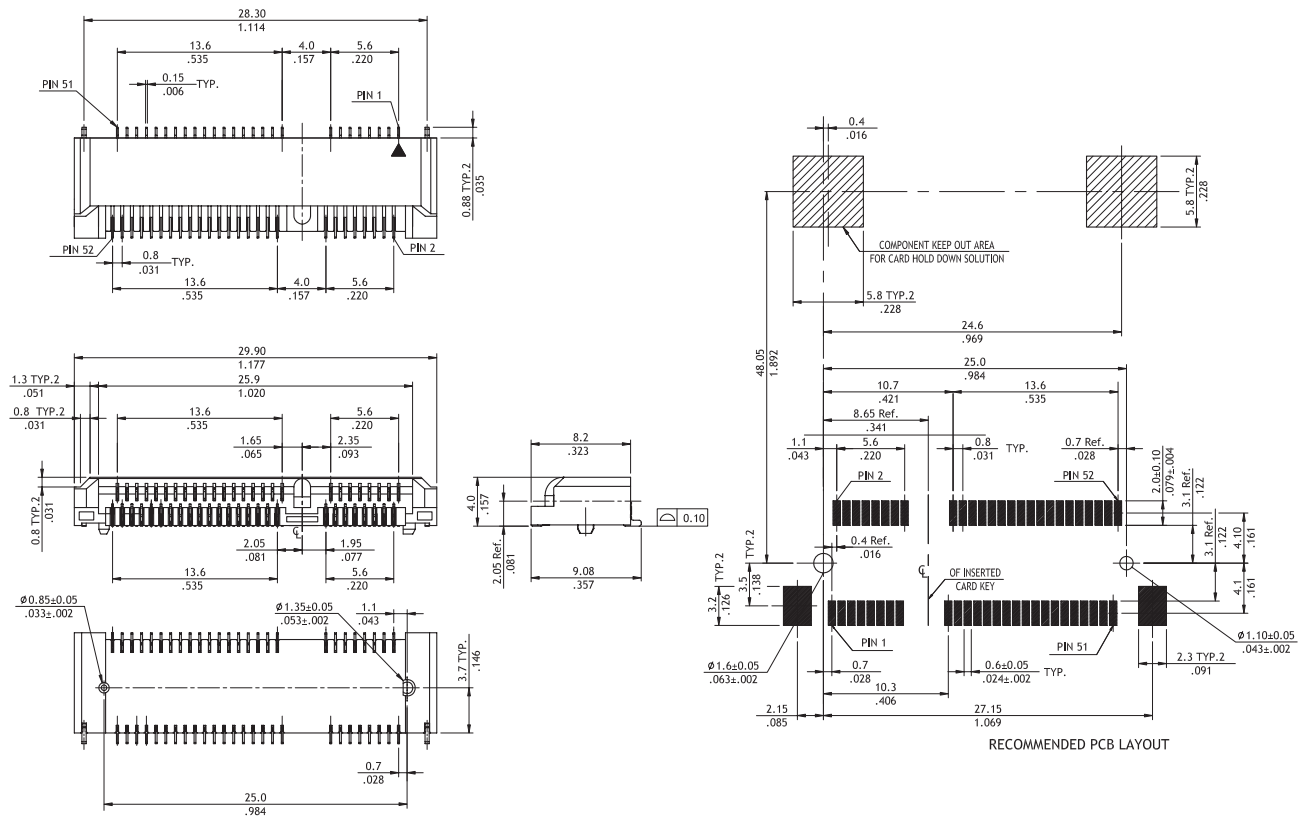

Ordering Code

①	②	③	④	⑤	⑥
CS59	52	M	A	1	R0

- ① Series No.
- ② No. of Circuits: 52
- ③ Tail Style: M = SMT Type

- ④ Plating Options:  
A = Selective Gold flash over Nickel
- ⑤ Color: 1 = Black
- ⑥ Packing Options: R0 = Tape & Reel

CS

SOCKETS



CS01 Series 2.54mm(.100") Dual Row Multiple Shunts

- ⊙ Available variety of body height
- ⊙ Handle type available
- ⊙ Low cost and reliable
- ⊙ Color code option " \* " 1 = Black, 3 = Red, 7 = Blue
- ⊙ Gold flash plated as standard

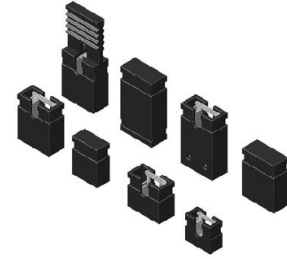

RoHS Compliant

<p>P/N CS01342B*00</p>	<p>P/N CS01502A*00</p>
<p>P/N CS01602B*00</p>	<p>P/N CS01632A*00</p>
<p>P/N CS01802B*00</p>	<p>P/N CS01852A*00</p>
<p>P/N CS01452B*00</p>	<p>P/N CS01X12A*00</p>

## CS07 Series 2.54mm (.100") DIP Socket - Machined contacts

- ⊙ High reliability screwed machined terminals with multiple finger contacts
- ⊙ Sealed and prevent flux wicking
- ⊙ Insulator: Glass filled polyester
- ⊙ Contact: Gold plated Beryllium copper
- ⊙ Sleeve: Tin plated copper alloy

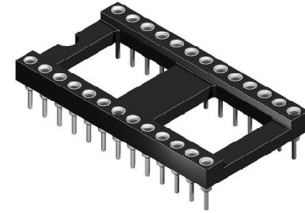

**RoHS** Compliant

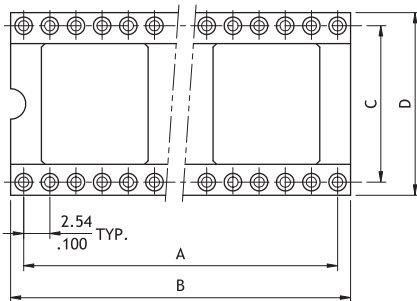

Circuits	CviLux P/N	Dimension			
		A	B	C	D
6	CS0706D1000	5.08(.200)	7.62(.300)	7.62(.300)	10.04(.395)
8	CS0708D1000	7.62(.300)	10.16(.400)	7.62(.300)	10.04(.395)
14	CS0714D1000	15.24(.600)	17.78(.700)	7.62(.300)	10.04(.395)
16	CS0716D1000	17.78(.700)	20.32(.800)	7.62(.300)	10.04(.395)
18	CS0718D1000	20.32(.800)	22.86(.900)	7.62(.300)	10.04(.395)
20	CS0720D1000	22.86(.900)	25.40(1.000)	7.62(.300)	10.04(.395)
24	CS0724D1000	27.94(1.100)	30.48(1.200)	7.62(.300)	10.04(.395)
	CS0724D1A00			15.24(.600)	17.72(.698)
28	CS0728D1000	33.02(1.300)	35.56(1.400)	7.62(.300)	10.04(.395)
	CS0728D1A00			15.24(.600)	17.72(.698)
32	CS0732D1A00	38.10(1.500)	40.64(1.600)	15.24(.600)	17.72(.698)
40	CS0740D1A00	48.26(1.900)	50.80(2.000)	15.24(.600)	17.72(.698)
42	CS0742D1A00	50.80(2.000)	53.34(2.100)	15.24(.600)	17.72(.698)
48	CS0748D1A00	58.42(2.300)	60.96(2.400)	15.24(.600)	17.72(.698)

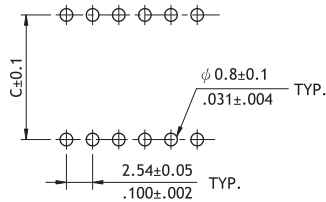
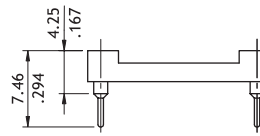
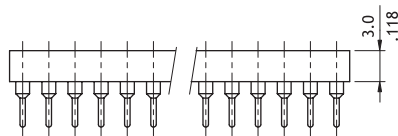

Recommended P.C. Board Layout

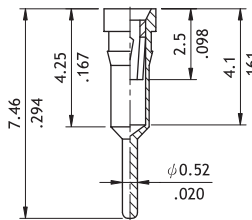

Pin detail

### Ordering Code

① CS07    ② 48    ③ D    ④ 1    ⑤ A00

- ① Series No.
- ② No. of Circuits: See above table
- ③ Plating Code:  
D = Selective 10μ" Gold flash over Nickel

- ④ Color: 1 = Black
- ⑤ Other Options:  
000 = DIM.D: 10.04mm  
A00 = DIM.D: 17.72mm  
\*Special options consult manufacturer

**CS09 Series 2.54mm(.100") Single in Line Adapter Strip**

- ⊙ Machined contact
- ⊙ Highly reliable board interconnecting

RoHS Compliant  

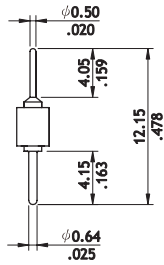
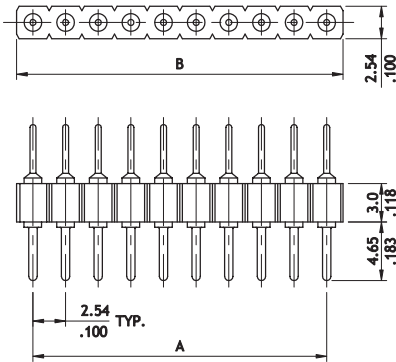
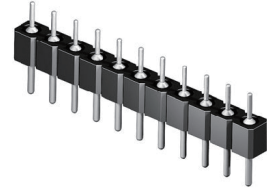

$A = 2.54 * \text{No. of Spaces}$   
 $B = A + 2.54$

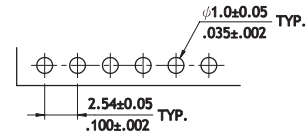

Recommended P.C. Board Layout

**Ordering Code**

① CS09 ② 40 ③ 2 ④ 1 ⑤ A00

- ① Series No.
- ② No. of Circuits: 02 ~ 40
- ③ Plating Code: 2 = Gold flash over Nickel
- ④ Color: 1 = Black
- ⑤ Other Options: A00 = Standard  
 \*Special options consult manufacturer

**CS10 Series 2.54mm(.100") Single in Line SIP Socket**

- ⊙ High reliability screwed machined terminals with multiple finger contacts
- ⊙ Sealed and prevent flux wicking
- ⊙ Insulator: PPS UL 94V-0
- ⊙ Contact: Gold Beryllium copper

RoHS Compliant

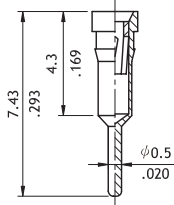
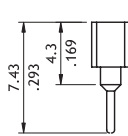
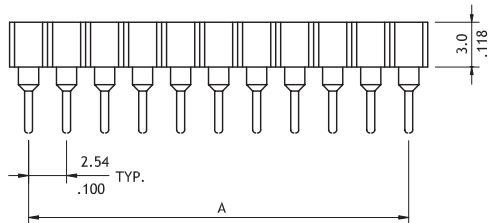
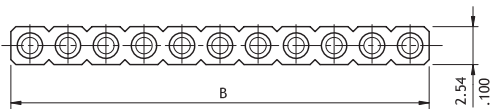
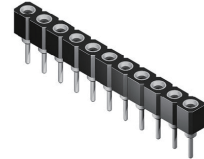

Pin detail

$A = 2.54 * \text{No. of Spaces}$   
 $B = A + 2.54$

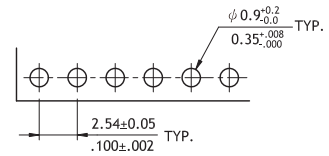

Recommended P.C. Board Layout

**Ordering Code**

① CS10 ② 40 ③ D ④ 1 ⑤ 000

- ① Series No.
- ② No. of Circuits: 02 ~ 20
- ③ Plating Code: D = Selective 10µ" Gold flash over Nickel
- ④ Color: 1 = Black
- ⑤ Other Options : 000 = Standard  
 \*Special options consult manufacturer

## CS74 Series PCI EXPRESS EDGE CARD Connector

- ⊙ PCIe Connector
- ⊙ Insulation : LCP UL 94V-0 , Color Black
- ⊙ Terminal : Phosphor Bronze , T = 0.25mm
- ⊙ Cover : LCP UL 94V-0 , Color Black

RoHS Compliant

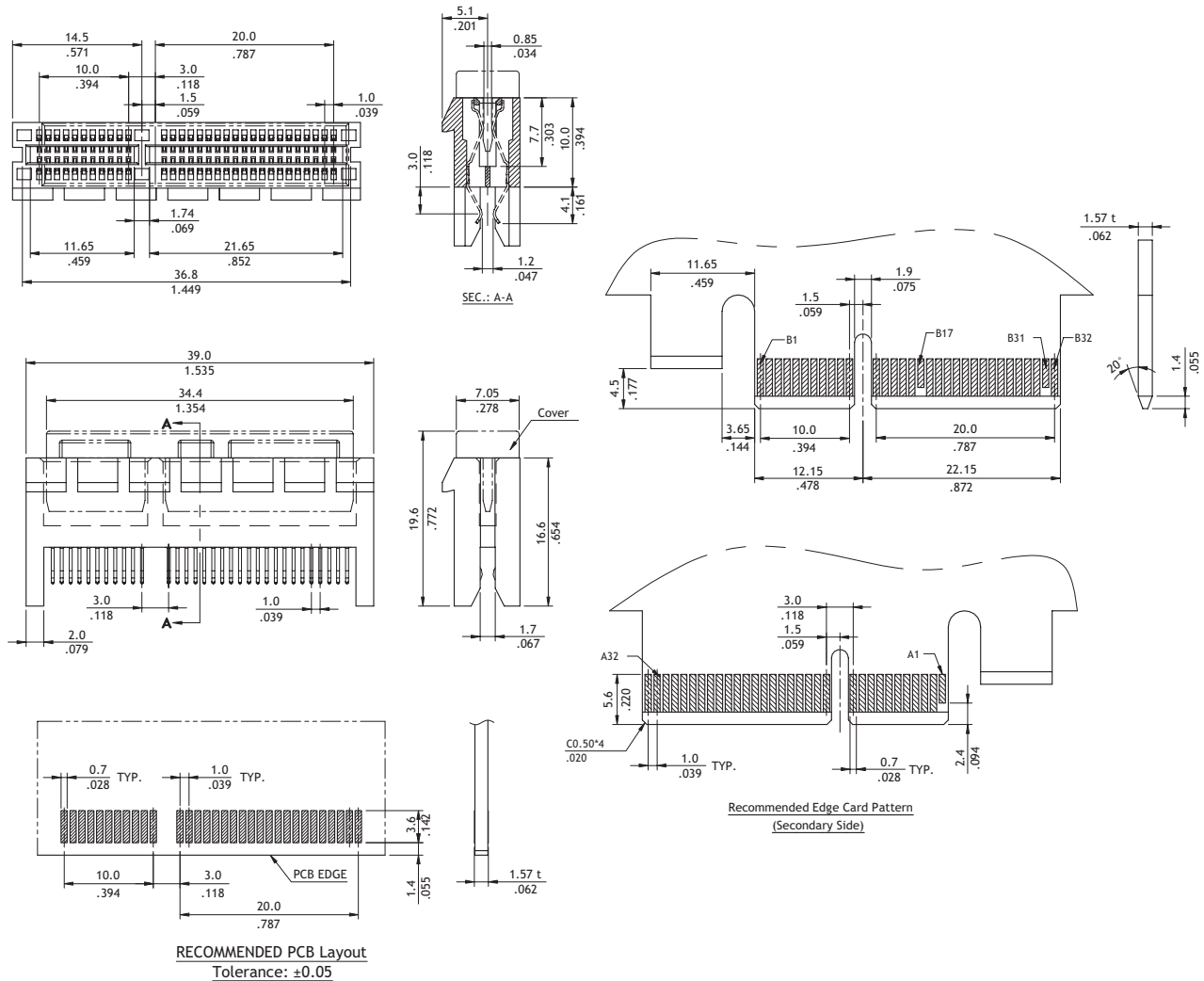
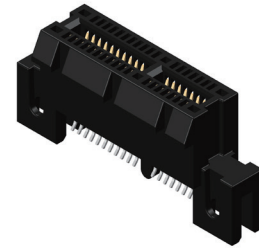

### Ordering Code

①	②	③	④	⑤	⑥
CS74	064	A	1	C	1

- ① Series No.
- ② No. of Circuits: 64
- ③ Plating Code:  
A = Selective Gold flash over Nickel
- ④ Color : 1 = Black
- ⑤ Tail Style : C= PCB Clip Type
- ⑥ 1 =With Baffle & Solder tail Contact position 3.0mm

CSM2 Series Micro SIM Card Connectors

- Micro Sim card connector
- Height: 1.5/1.18mm

RoHS Compliant 

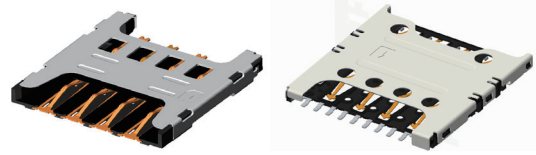

P/N CSM20821A00

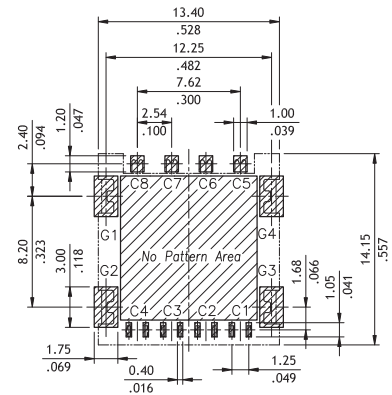
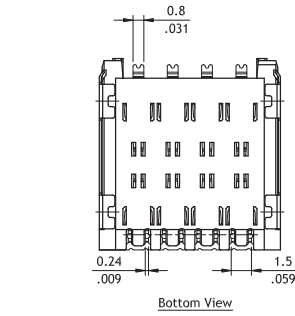
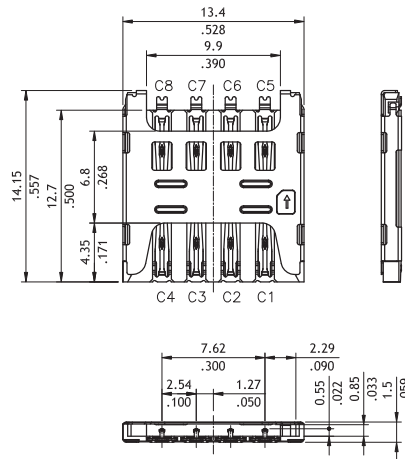

Recommended P.C. Board Layout  
General Tolerance: ±0.05

P/N CSM20821B00

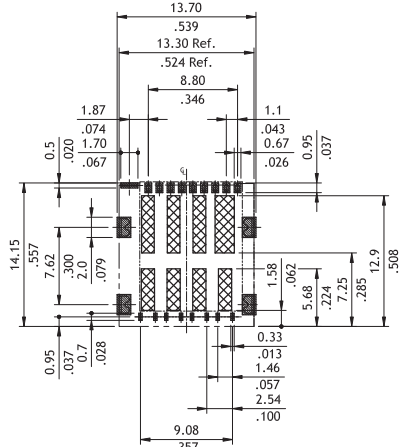
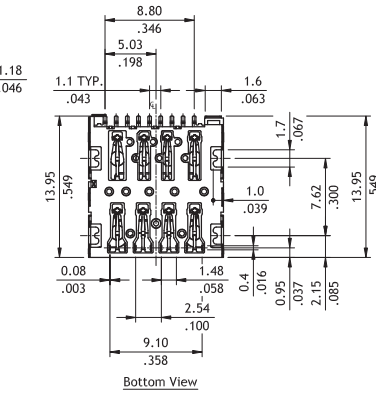
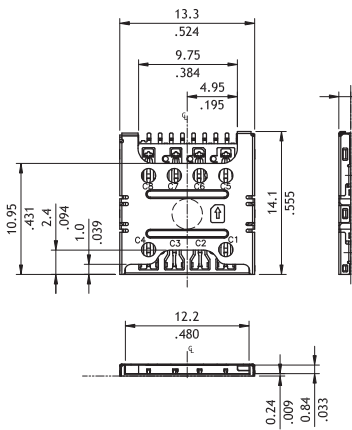

Recommended P.C. Board Layout  
General Tolerance: ±0.05

Ordering Code

① CSM ② 2 ③ 08 ④ 1 ⑤ A00

- ① Series No.
- ② No. of contacts : 08
- ③ Plating option:  
2 = Gold flash over Nickel
- ④ Insulator Color : 1=Black
- ⑤ A00: H=1.5 mm  
B00: H=1.18 mm

## D-Sub Shell Size

D-SUB CONNECTOR	HIGH DENSITY D-SUB CONNECTOR	SHELL SIZE	
9 Positions	15 Positions	E	
15 Positions	26 Positions	A	
25 Positions	44 Positions	B	
37 Positions	62 Positions	C	
50 Positions	78 Positions	D	

## D-Sub Printed Circuits Board Hole Patterns

<p>9 Positions</p>	<p>25 Positions</p>
<p>15 Positions</p>	<p>37 Positions</p>
<p>50 Positions</p>	

High Density D-Sub Straight DIP Solder Printed Circuits Board Hole Patterns

	Plug	Receptacle
15 Positions		
26 Positions		
44 Positions		
62 Positions		

CD

High Density D-Sub Right Angle DIP Solder Printed Circuits Board Hole Patterns

	Plug	Receptacle
15 Positions		
26 Positions		
44 Positions		
62 Positions		

D-SUB CONNECTORS

D-Sub Accessories

<p>P/N : CDHWE123000</p> <table border="1"> <thead> <tr> <th>NO</th> <th>PART NO.</th> <th>DESCRIPTION</th> </tr> </thead> <tbody> <tr> <td>1</td> <td>CDHWE105S00</td> <td>ATTACHED SCREW</td> </tr> <tr> <td>2</td> <td>CDHW0001W00</td> <td>FLAT WASHER</td> </tr> <tr> <td>3</td> <td>CDHW0002W00</td> <td>SPLIT WASHER</td> </tr> <tr> <td>4</td> <td>CDHWE101N00</td> <td>NUT</td> </tr> </tbody> </table>	NO	PART NO.	DESCRIPTION	1	CDHWE105S00	ATTACHED SCREW	2	CDHW0001W00	FLAT WASHER	3	CDHW0002W00	SPLIT WASHER	4	CDHWE101N00	NUT	<p>P/N : CDHWE124000</p> <table border="1"> <thead> <tr> <th>NO</th> <th>PART NO.</th> <th>DESCRIPTION</th> </tr> </thead> <tbody> <tr> <td>1</td> <td>CDHWE106S00</td> <td>ATTACHED SCREW</td> </tr> <tr> <td>2</td> <td>CDHWE101N00</td> <td>NUT</td> </tr> </tbody> </table>	NO	PART NO.	DESCRIPTION	1	CDHWE106S00	ATTACHED SCREW	2	CDHWE101N00	NUT	<p>P/N : CDHWE128000</p> <p>P/N : CDHWE108S00</p> <p>P/N : CDHW0004L00</p>
NO	PART NO.	DESCRIPTION																								
1	CDHWE105S00	ATTACHED SCREW																								
2	CDHW0001W00	FLAT WASHER																								
3	CDHW0002W00	SPLIT WASHER																								
4	CDHWE101N00	NUT																								
NO	PART NO.	DESCRIPTION																								
1	CDHWE106S00	ATTACHED SCREW																								
2	CDHWE101N00	NUT																								
<p>P/N : CDHWE110S00</p>	<p>P/N : CDHWE***S00</p> <table border="1"> <thead> <tr> <th>Part No.</th> <th>Dimension A</th> </tr> </thead> <tbody> <tr> <td>CDHWE101S00</td> <td>11.8(.465)</td> </tr> <tr> <td>CDHWE105S00</td> <td>12.7(.500)</td> </tr> <tr> <td>CDHWE106S00</td> <td>10.0(.394)</td> </tr> <tr> <td>CDHWE107S00</td> <td>17.8(.701)</td> </tr> </tbody> </table>	Part No.	Dimension A	CDHWE101S00	11.8(.465)	CDHWE105S00	12.7(.500)	CDHWE106S00	10.0(.394)	CDHWE107S00	17.8(.701)															
Part No.	Dimension A																									
CDHWE101S00	11.8(.465)																									
CDHWE105S00	12.7(.500)																									
CDHWE106S00	10.0(.394)																									
CDHWE107S00	17.8(.701)																									

D-Sub PCB Mounting Options

<p><b>O</b> Riveted front and rear shell with <math>\phi 3.05\text{mm}</math> Hole</p>	<p><b>C</b> Riveted #4-40 UNC open nuts on rear shell DIM. L= 4.0mm (Standard)</p>	<p><b>D</b> Riveted #4-40 UNC close ground stand-off on rear shell</p> <p>Stamped contact (DIM. L= 6.0 mm)      Machined contact (DIM. L= 7.4 mm)</p>
<p><b>A</b> Riveted #4-40 UNC close nuts on front shell DIM. L= 5.8mm (Standard)</p>	<p><b>F</b> Riveted ground hooks with #4-40 UNC open</p>	<p><b>I</b> Riveted ground tabs with #4-40 UNC open</p> <p>Stamped contact      Machined contact</p>
<p><b>B</b> Riveted #4-40 UNC open nuts on front shell DIM. L= 4.0mm (Standard)</p>	<p><b>G</b> Riveted ground hooks pre-loaded #4-40 UNC Hex screws</p>	<p><b>J</b> Assembly ground hooks by #4-40 UNC Hex screws</p> <p>Stamped contact      Machined contact</p>

**CD01 Series High Density Solder D-Sub**

- ⊙ Mate with high density D-Sub
- ⊙ With metal shell and solder contacts
- ⊙ Riveted Hex nuts options available

RoHS Compliant

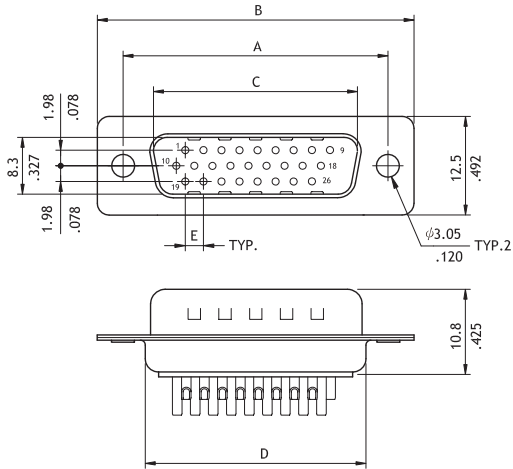
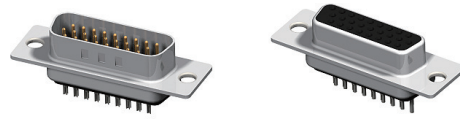

Plug Connector

Circuits	Dimension				
	A	B	C	D	E
15	25.0(.984)	30.8(1.213)	16.92(.666)	19.3(.760)	2.29(.090)
26	33.32(1.312)	39.2(1.543)	25.25(.994)	27.7(1.091)	2.29(.090)
44	47.04(1.852)	53.1(2.091)	38.96(1.534)	41.1(1.618)	2.29(.090)
62	63.5(2.500)	69.4(2.732)	55.42(2.182)	57.3(2.256)	2.41(.095)

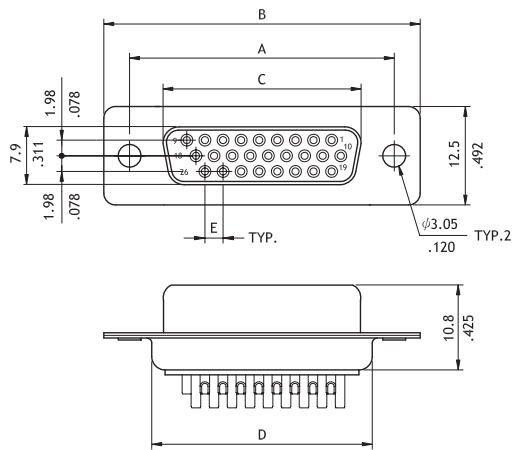
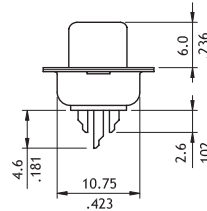

Receptacle connector

Circuits	Dimension				
	A	B	C	D	E
15	25.0(.984)	30.8(1.213)	16.3(.642)	19.2(.756)	2.29(.090)
26	33.32(1.312)	39.2(1.543)	24.6(.969)	27.7(1.091)	2.29(.090)
44	47.04(1.852)	53.1(2.091)	38.3(1.508)	41.1(1.618)	2.29(.090)
62	63.5(2.500)	69.4(2.732)	54.8(2.157)	57.3(2.256)	2.41(.095)

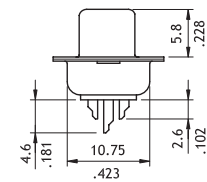

**Ordering Code**

① ② ③ ④ ⑤ ⑥  
**CD01 15 P A 1 00**

- ① Series No.
- ② No. of Circuits: 15, 26, 44, 62
- ③ Connector Type: P = Plug  
S = Receptacle
- ④ Plating Code: A = Selective Gold flash over Nickel  
\*Optional plating available but MOQ requested
- ⑤ Insulator Color: 1 = Black  
\*Optional insulator color consult manufacturer

- ⑥ Other Options:  
 00 = With  $\phi$  3.05mm holes on shell (Standard)  
 A0 = Riveted #4-40 UNC Close nuts on Front shell  
 B0 = Riveted #4-40 UNC Open nuts on Front shell  
 C0 = Riveted #4-40 UNC Open nuts on Rear shell  
 \*Special options consult manufacturer

CD

D-SUB CONNECTORS

### CD51 Series Solder D-Sub

- ⊙ Mate with standard D-Sub
- ⊙ With metal shell and solder contacts
- ⊙ Riveted Hex nuts options available

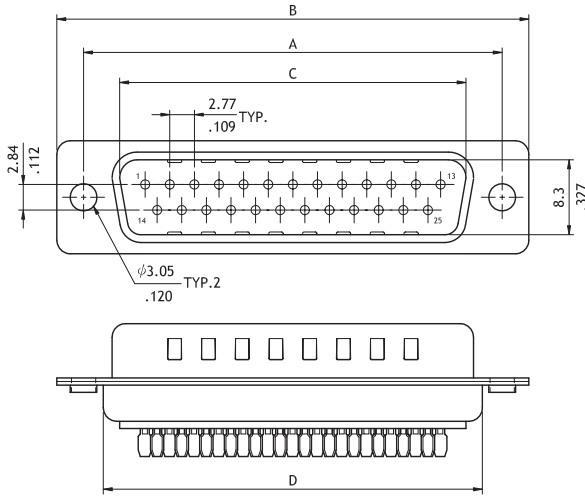
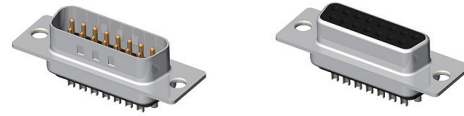

Plug Connector

Circuits	Dimension			
	A	B	C	D
9	25.0(.984)	30.8(1.213)	16.92(.666)	19.2(.756)
15	33.32(1.312)	39.2(1.543)	25.25(.994)	27.7(1.091)
25	47.04(1.852)	53.1(2.091)	38.96(1.534)	41.1(1.618)
37	63.5(2.500)	69.4(2.732)	55.42(2.182)	57.3(2.256)

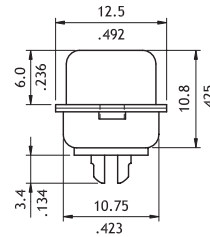

Receptacle connector

Circuits	Dimension			
	A	B	C	D
9	25.0(.984)	30.8(1.213)	16.3(.642)	19.2(.756)
15	33.32(1.312)	39.2(1.543)	24.6(.969)	27.7(1.091)
25	47.04(1.852)	53.1(2.091)	38.3(1.508)	41.1(1.618)
37	63.5(2.500)	69.4(2.732)	54.8(2.157)	57.3(2.256)

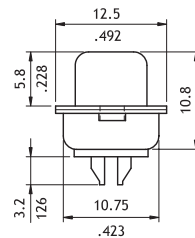

#### Ordering Code

① ② ③ ④ ⑤ ⑥  
**CD51 25 P A 1 00**

- ① Series No.
- ② No. of Circuits: 09, 15, 25, 37
- ③ Connector Type: P = Plug  
S = Receptacle
- ④ Plating Code : A = Selective Gold flash over Nickel  
\*Optional plating available but MOQ requested
- ⑤ Insulator Color: 1 = Black  
\*Optional insulator color consult manufacturer

- ⑥ Other Options:  
 00 = With  $\phi 3.05$ mm holes on shell (Standard)  
 A0 = Riveted #4-40 UNC Close nuts on Front shell  
 B0 = Riveted #4-40 UNC Open nuts on Front shell  
 C0 = Riveted #4-40 UNC Open nuts on Rear shell  
 \*Special options consult manufacturer

**CD52 Series Crimp Clip D-Sub**

- ⊙ Mate with standard D-Sub
- ⊙ Riveted Hex nuts options available

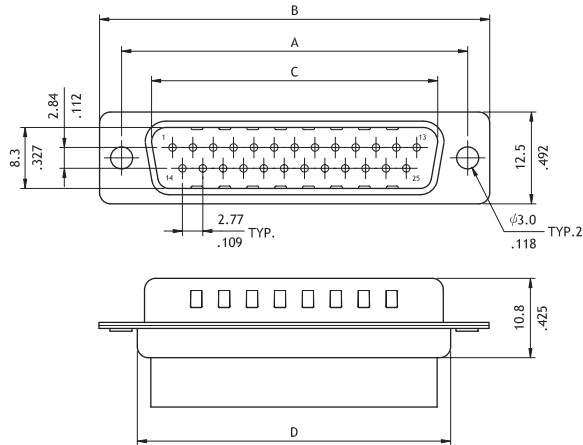

Plug Connector

Circuits	Dimension			
	A	B	C	D
9	25.0(.984)	30.8(1.213)	16.92(.666)	19.2(.756)
15	33.32(1.312)	39.2(1.543)	25.25(.994)	27.7(1.091)
25	47.04(1.852)	53.1(2.091)	38.96(1.534)	41.1(1.618)
37	63.5(2.500)	69.4(2.732)	55.42(2.182)	57.3(2.256)

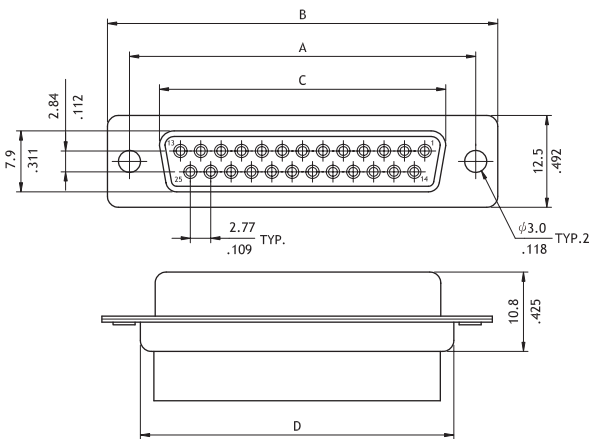
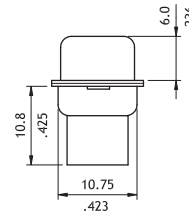

Receptacle connector

Circuits	Dimension			
	A	B	C	D
9	25.0(.984)	30.8(1.213)	16.3(.642)	19.2(.756)
15	33.32(1.312)	39.2(1.543)	24.6(.969)	27.7(1.091)
25	47.04(1.852)	53.1(2.091)	38.3(1.508)	41.1(1.618)
37	63.5(2.500)	69.4(2.732)	54.8(2.157)	57.3(2.256)

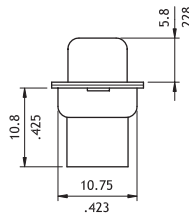

**Ordering Code**

① CD52 ② 25 ③ P0 ④ 1 ⑤ 00

- ① Series No.
- ② No. of Circuits: 09, 15, 25, 37
- ③ Connector Type: P0 = Plug  
S0 = Receptacle
- ④ Insulator Color: 1 = Black  
\*Optional insulator color consult manufacturer

- ⑤ Other Options:  
00 = With φ 3.05mm holes on shell (Standard)  
A0 = Riveted #4-40 UNC Close nuts on Front shell  
B0 = Riveted #4-40 UNC Open nuts on Front shell  
C0 = Riveted #4-40 UNC Open nuts on Rear shell  
\*Special options consult manufacturer

## CD52 Series Crimp Clip Terminal

- ☉ Mate with Cvilux CD52 D-Sub
- ☉ Low insertion force

RoHS Compliant

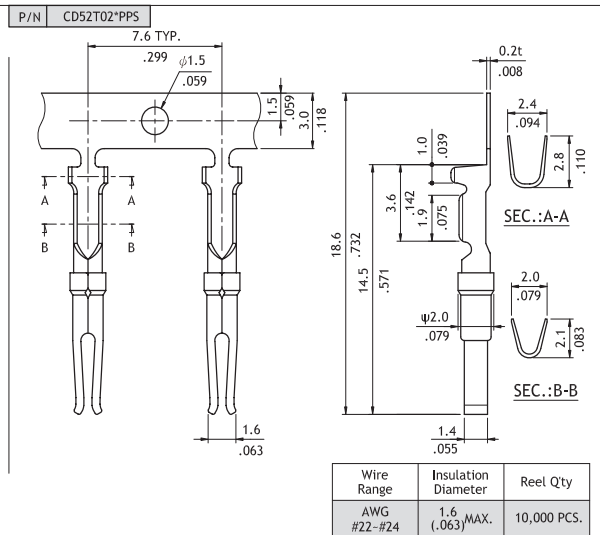
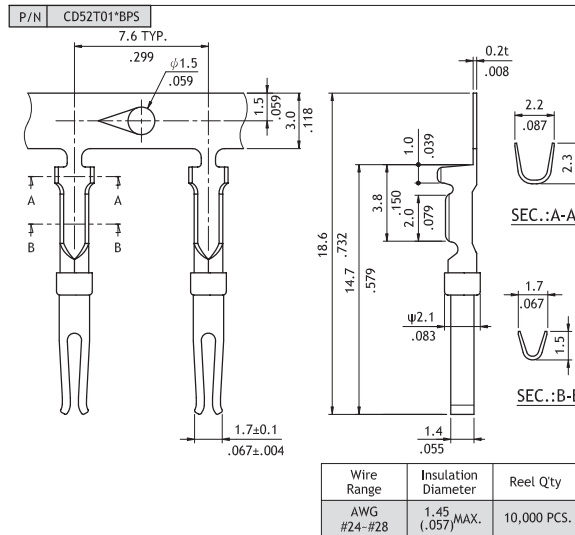
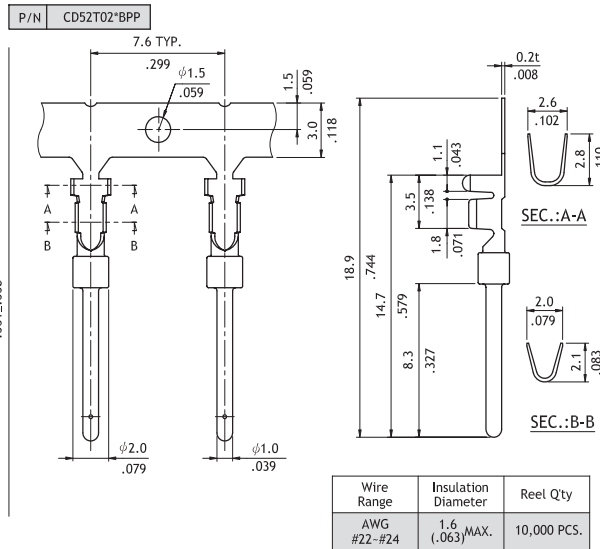
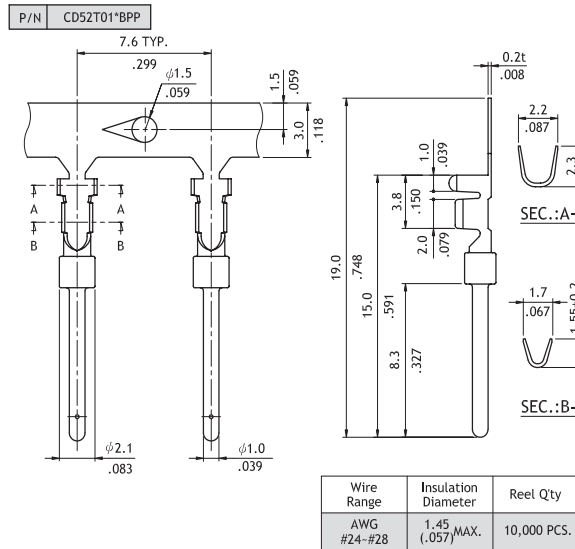
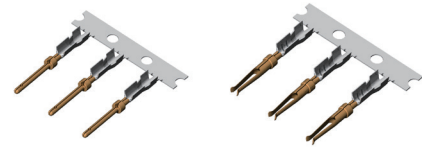

### Ordering Code

① CD52 ② T01 ③ A ④ B ⑤ PP

- ① Series No.
- ② Terminal Style:  
T01 = for AWG #24 ~ #28  
T02 = for AWG #22 ~ #24
- ③ Plating Code:  
A = Selective Gold flash over Nickel  
\*Optional plating available but MOQ requested
- ④ Material: B = Brass (Plug)  
P = Phosphor Bronze (Receptacle)
- ⑤ Type: PP = Plug Terminal  
PS = Receptacle Terminal

**CD53 Series Straight DIP Solder D-Sub**

- ⊙ Mate with standard D-Sub
- ⊙ With metal shell and solder contacts
- ⊙ Riveted Hex nuts options available

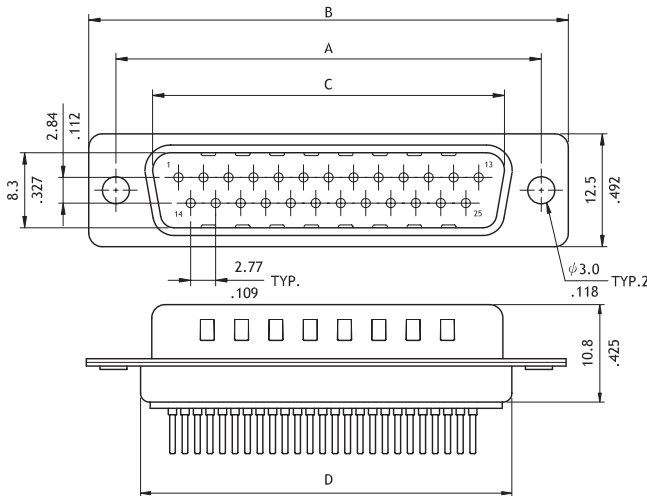
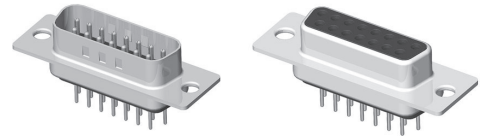

Plug Connector

Circuits	Dimension			
	A	B	C	D
9	25.0(.984)	30.8(1.213)	16.92(.666)	19.2(.756)
15	33.32(1.312)	39.2(1.543)	25.25(.994)	27.7(1.091)
25	47.04(1.852)	53.1(2.091)	38.96(1.534)	41.1(1.618)
37	63.5(2.500)	69.4(2.732)	55.42(2.182)	57.3(2.256)

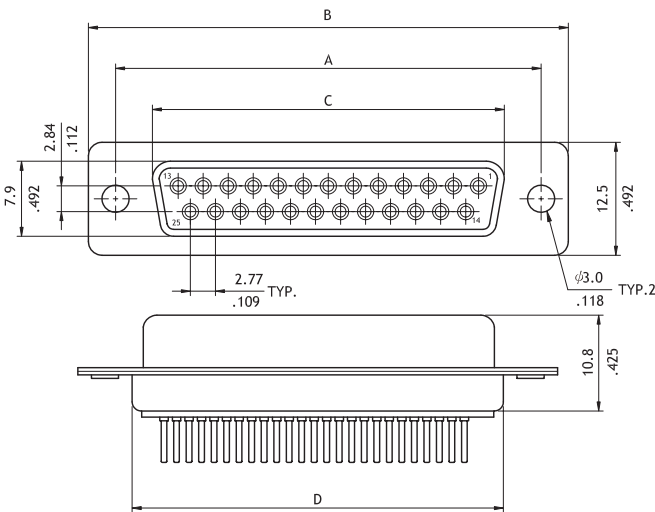
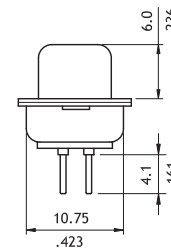

Receptacle connector

Circuits	Dimension			
	A	B	C	D
9	25.0(.984)	30.8(1.213)	16.3(.642)	19.2(.756)
15	33.32(1.312)	39.2(1.543)	24.6(.969)	27.7(1.091)
25	47.04(1.852)	53.1(2.091)	38.3(1.508)	41.1(1.618)
37	63.5(2.500)	69.4(2.732)	54.8(2.157)	57.3(2.256)

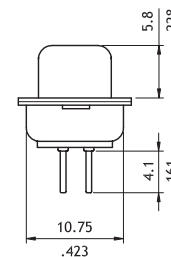

**Ordering Code**

① ② ③ ④ ⑤ ⑥  
**CD53 25 P 2 1 00**

- ① Series No.
- ② No. of Circuits: 09, 15, 25, 37
- ③ Connector Type:  
P = Plug (Male) S = Receptacle (Female)
- ④ Plating Code:  
2 = Gold flash over Nickel  
A = Selective Gold flash over Nickel  
\*Optional plating available but MOQ requested
- ⑤ Insulator Color: 1 = Black  
\*Optional insulator color consult manufacturer
- ⑥ Other Options:  
00 = With  $\phi 3.05$ mm holes on shell (Standard)  
B0 = Riveted #4-40 UNC Open nuts on Front shell  
C0 = Riveted #4-40 UNC Open nuts on Rear shell  
D0 = Riveted #4-40 UNC Ground stand-off on Rear shell  
\*Special options consult manufacturer

CD

D-SUB CONNECTORS

**CD61 Series 8.10mm Footprint Right Angle DIP Solder D-Sub**

- ⊙ Mate with standard D-Sub
- ⊙ With metal shell and solder contacts
- ⊙ Ground hooks or ground tabs available

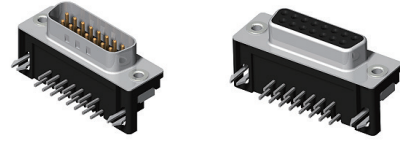

RoHS Compliant

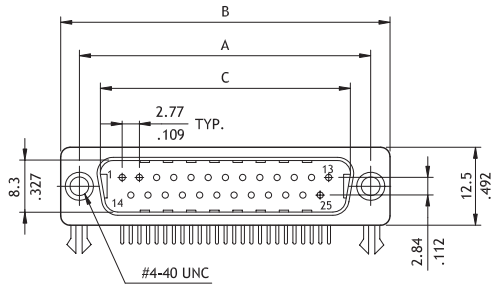

Plug Connector

Circuits	Dimension		
	A	B	C
9	25.0(.984)	30.8(1.213)	16.92(.666)
15	33.32(1.312)	39.2(1.543)	25.25(.994)
25	47.04(1.852)	53.1(2.091)	38.96(1.534)
37	63.5(2.500)	69.4(2.732)	55.42(2.182)

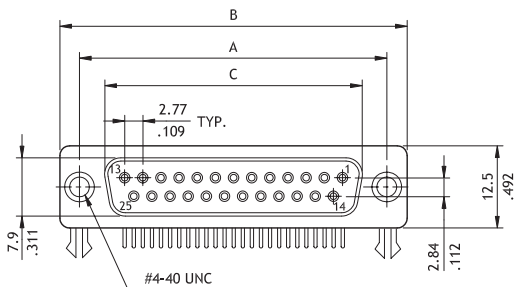
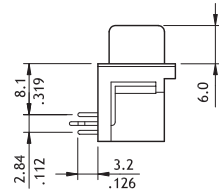
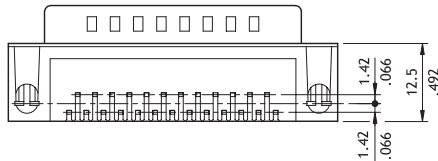

Receptacle connector

Circuits	Dimension		
	A	B	C
9	25.0(.984)	30.8(1.213)	16.3(.642)
15	33.32(1.312)	39.2(1.543)	24.6(.969)
25	47.04(1.852)	53.1(2.091)	38.3(1.508)
37	63.5(2.500)	69.4(2.732)	54.8(2.157)

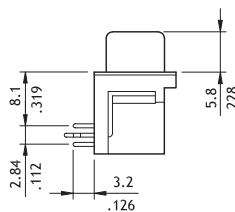
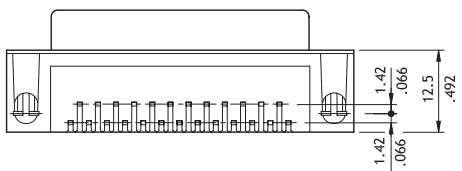

**Ordering Code**

① ② ③ ④ ⑤ ⑥  
**CD61 25 P 2 1 F0**

- ① Series No.
- ② No. of Circuits: 09, 15, 25, 37
- ③ Connector Type: P = Plug  
S = Receptacle
- ④ Plating Code:  
2 = Gold flash over Nickel  
A = Selective Gold flash over Nickel  
\*Optional plating available but MOQ requested
- ⑤ Insulator Color: 1 = Black  
\*Optional insulator color consult manufacturer
- ⑥ Other Options:  
F0 = Riveted ground hooks with #4-40 UNC Open (Standard)  
J0 = Assembly ground hooks by #4-40 UNC Hex screws  
G0 = Riveted ground hooks pre-loaded #4-40 UNC Hex screws  
\*Special options consult manufacturer

**CD62 Series 8.10mm Footprint EMI Right Angle DIP Solder D-Sub**

- ⊙ Mate with standard D-Sub
- ⊙ With ferrite core
- ⊙ Optional ground hooks or ground tabs

RoHS Compliant

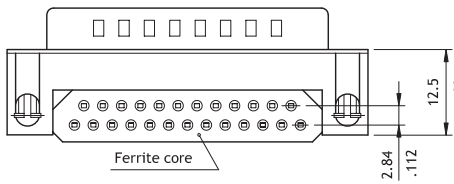
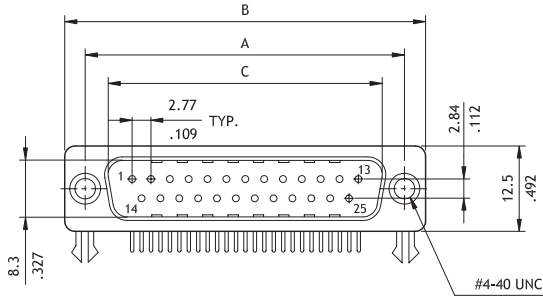
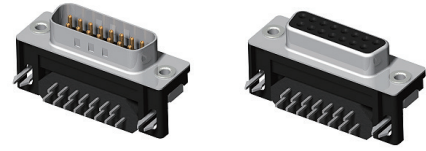

Plug Connector

Circuits	Dimension		
	A	B	C
9	25.0(.984)	30.8(1.213)	16.92(.666)
15	33.32(1.312)	39.2(1.543)	25.25(.994)
25	47.04(1.852)	53.1(2.087)	38.96(1.534)
37	63.5(2.500)	69.4(2.732)	55.42(2.182)

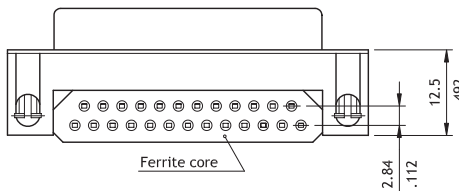
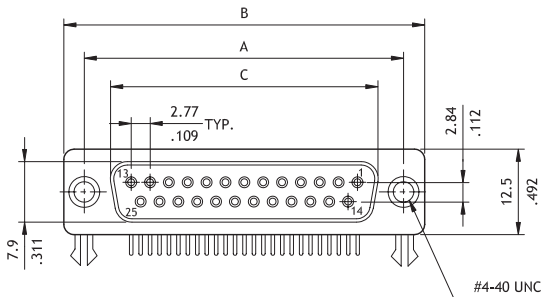
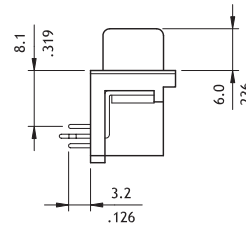

Receptacle connector

Circuits	Dimension		
	A	B	C
9	25.0(.984)	30.8(1.213)	16.3(.642)
15	33.32(1.312)	39.2(1.543)	24.6(.969)
25	47.04(1.852)	53.1(2.091)	38.3(1.508)
37	63.5(2.500)	69.4(2.732)	54.8(2.157)

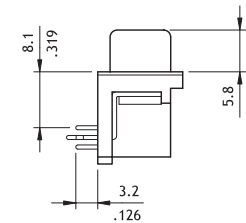

CD

**Ordering Code**

① ② ③ ④ ⑤ ⑥  
**CD62 25 P 2 1 F0**

- ① Series No.
- ② No. of Circuits: 09, 15, 25, 37
- ③ Connector Type: P = Plug  
S = Receptacle
- ④ Plating Code:  
2 = Gold flash over Nickel  
\*Optional plating available but MOQ requested
- ⑤ Insulator Color: 1 = Black

- ⑥ Other Options:  
F0 = Riveted ground hooks with #4-40 UNC Open (Standard)  
I0 = Riveted ground tabs thread #4-40 UNC Open and ground tabs with  $\phi$  3.2mm holes  
J0 = Assembly ground hooks by #4-40 UNC Hex screws  
G0 = Riveted ground hooks pre-loaded #4-40 UNC Hex screws  
\*Special options consult manufacturer

## CD91 Series Flat Cable - IDC D-Sub

- ⊙ Mate with standard D-Sub and CW03
- ⊙ Flat Ribbon Cable
- ⊙ ø3.4mm holes or riveted insert nuts available

RoHS Compliant

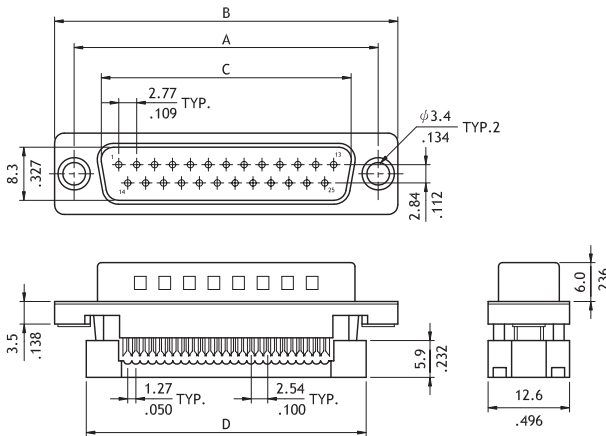

Plug Connector

Circuits	Dimension				
	A	B	C	D	E
9	25.0(.984)	30.8(1.213)	16.92(.666)	22.4(.882)	12.08(.476)
15	33.3(1.311)	39.2(1.543)	25.25(.994)	30.8(1.213)	19.7(.776)
25	47.1(1.854)	53.1(2.091)	38.96(1.534)	44.5(1.752)	32.4(1.276)
37	63.5(2.500)	69.4(2.732)	55.42(2.182)	61.4(2.417)	47.72(1.879)

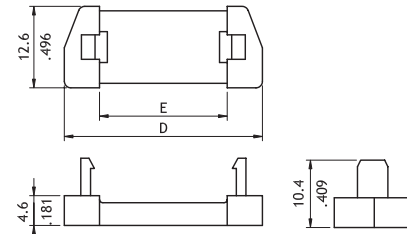

Strain relief

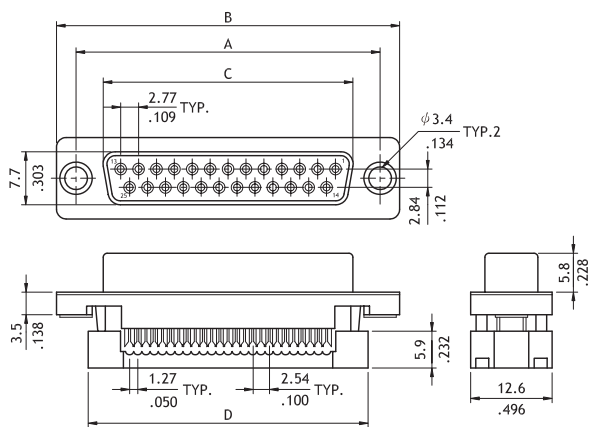

Receptacle connector

Circuits	Dimension				
	A	B	C	D	E
9	25.0(.984)	30.8(1.213)	16.3(.642)	22.4(.882)	12.08(.476)
15	33.3(1.311)	39.2(1.543)	24.6(.969)	30.8(1.213)	19.7(.776)
25	47.1(1.854)	53.1(2.091)	38.3(1.508)	44.5(1.752)	32.4(1.276)
37	63.5(2.500)	69.4(2.732)	54.8(2.157)	61.4(2.417)	47.72(1.879)

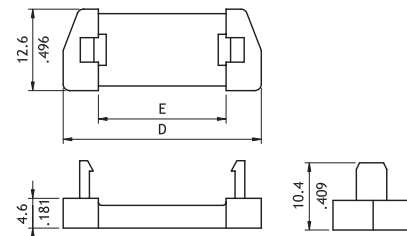

Strain relief

### Ordering Code

① ② ③ ④ ⑤ ⑥  
**CD91 25 P A 1 S0**

- ① Series No.
- ② No. of Circuits: 09, 15, 25, 37
- ③ Connector Type: P = Plug  
S = Receptacle
- ④ Plating Code : A = Selective Gold flash over Nickel  
\*Optional plating available but MOQ requested
- ⑤ Insulator Color: 1 = Black  
7 = Blue
- ⑥ Other Options:  
S0 = Metal shell with φ 3.4mm holes with S/R (Standard)  
S1 = Metal shell #4-40 UNC insert nuts with S/R  
\*Special options consult manufacturer

CD81 Series Stacked Right Angle DIP Solder D-Sub

- ⊙ Mate with standard D-Sub
- ⊙ With metal shell and solder tails
- ⊙ Optional row spacing and position
- ⊙ In various pin configuration



RoHS Compliant

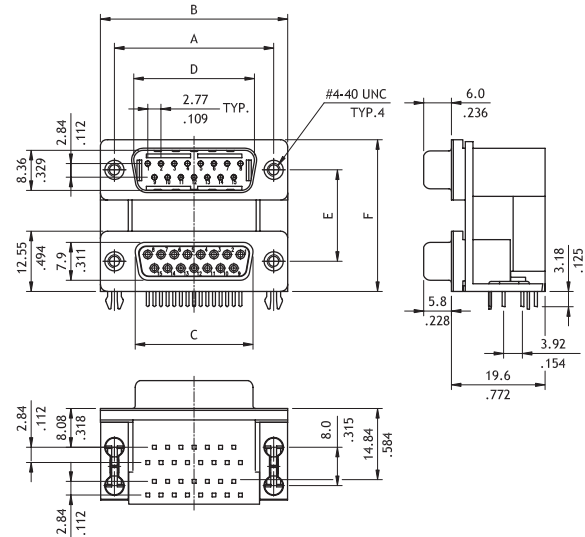
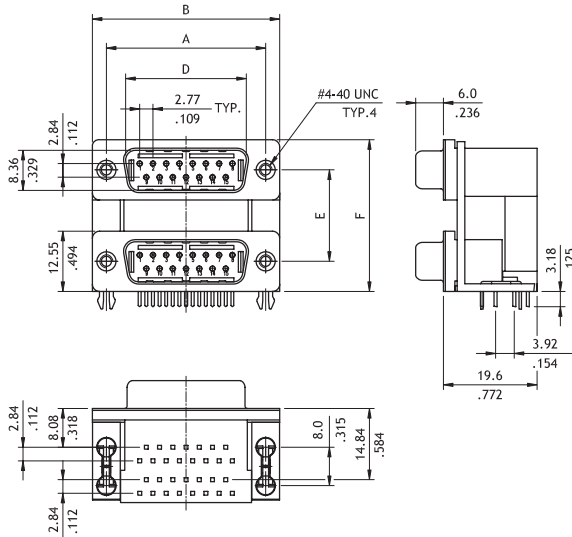

CIVILUX P/N	Dimension				
	A	B	D	E	F
CD81V1P**A*	24.99(.984)	30.81(1.213)	16.92(.666)	15.88(.625)	28.43(1.119)
CD81V2P**A*	33.32(1.312)	39.19(1.543)	25.25(.994)		
CD81V3P**A*	47.04(1.852)	53.04(2.088)	38.96(1.534)		
CD81V7P**A*	63.50(2.500)	69.32(2.729)	55.42(2.182)	19.05(.750)	31.60(1.244)
CD81V1P**B*	24.99(.984)	30.81(1.213)	16.92(.666)		
CD81V2P**B*	33.32(1.312)	39.19(1.543)	25.25(.994)		
CD81V3P**B*	47.04(1.852)	53.04(2.088)	38.96(1.534)	22.86(.900)	35.41(1.394)
CD81V7P**B*	63.50(2.500)	69.32(2.729)	55.42(2.182)		
CD81V1P**C*	24.99(.984)	30.81(1.213)	16.92(.666)		
CD81V2P**C*	33.32(1.312)	39.19(1.543)	25.25(.994)	22.86(.900)	35.41(1.394)
CD81V3P**C*	47.04(1.852)	53.04(2.088)	38.96(1.534)		
CD81V7P**C*	63.50(2.500)	69.32(2.729)	55.42(2.182)		

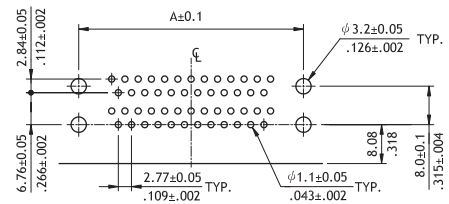

Recommended PCB Layout

Ordering Code

① CD ② 81 ③ V1 ④ PP ⑤ AA ⑥ C

- ① Series No.
- ② Contacts configuration:  
 V1 = 9 to 9, V2 = 15 to 15  
 V3 = 25 to 25, V4 = 9 to 25  
 V5 = 25 to 9, V6 = 25 to 15  
 V7 = 37 to 37
- ③ Connector Type:  
 PP = Plug to plug  
 PS = Plug to receptacle
- ④ Plating Code: A = Selective Gold flash over Nickel  
 \*Optional plating available but MOQ requested
- ⑤ Row Spacing: A: DIM.E = 15.88mm, B: DIM.E = 19.05mm  
 C: DIM.E = 22.86mm
- ⑥ Other Options:  
 C = Riveted ground hooks with #4-40 UNC open (Standard)  
 S = Riveted ground hooks pre-loaded #4-40 UNC Hex screws  
 \*Special options consult manufacturer

### CD81 Series Stacked Right Angle DIP Solder D-Sub

- ⊙ Mate with standard D-Sub
- ⊙ With metal shell and solder tails
- ⊙ Optional row spacing and position
- ⊙ In various pin configuration

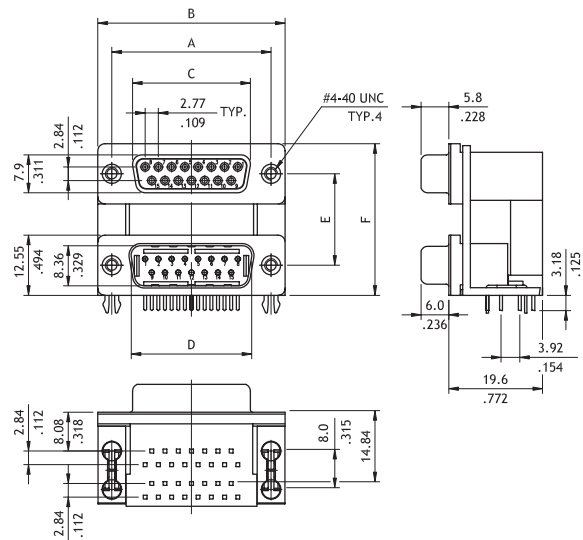
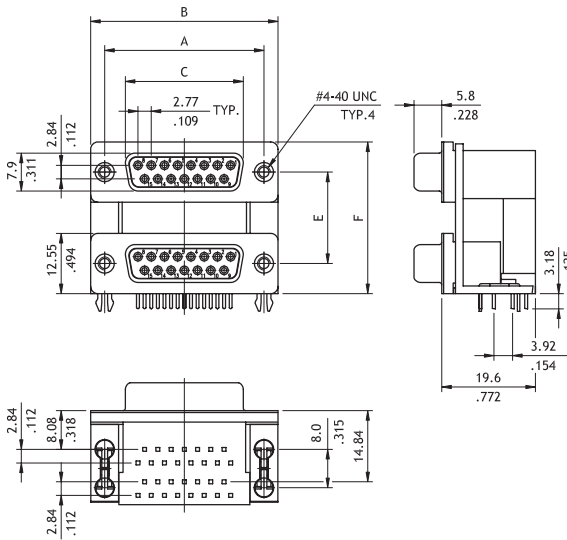

CVILUX P/N	Dimension					
	A	B	C	D	E	F
CD81V15S*A*	24.99(.984)	30.81(1.213)	16.33(.643)	16.92(.666)	15.88(.625)	28.43(1.119)
CD81V25S*A*	33.32(1.312)	39.19(1.543)	24.66(.971)	25.25(.994)		
CD81V35S*A*	47.04(1.852)	53.04(2.088)	38.38(1.511)	38.96(1.534)		
CD81V75S*A*	63.50(2.500)	69.32(2.729)	54.84(2.159)	55.42(2.182)	19.05(.750)	31.60(1.244)
CD81V15S*B*	24.99(.984)	30.81(1.213)	16.33(.643)	16.92(.666)		
CD81V25S*B*	33.32(1.312)	39.19(1.543)	24.66(.971)	25.25(.994)		
CD81V35S*B*	47.04(1.852)	53.04(2.088)	38.38(1.511)	38.96(1.534)	22.86(.900)	35.41(1.394)
CD81V75S*B*	63.50(2.500)	69.32(2.729)	54.84(2.159)	55.42(2.182)		
CD81V15S*C*	24.99(.984)	30.81(1.213)	16.33(.643)	16.92(.666)		
CD81V25S*C*	33.32(1.312)	39.19(1.543)	24.66(.971)	25.25(.994)	22.86(.900)	35.41(1.394)
CD81V35S*C*	47.04(1.852)	53.04(2.088)	38.38(1.511)	38.96(1.534)		
CD81V75S*C*	63.50(2.500)	69.32(2.729)	54.84(2.159)	55.42(2.182)		

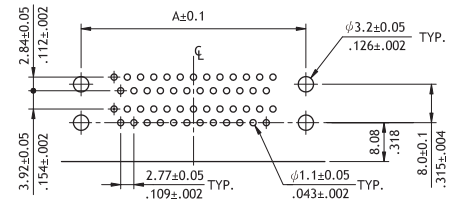

Recommended PCB Layout

#### Ordering Code



- ① Series No.
- ② Contacts configuration:  
 V1 = 9 to 9, V2 = 15 to 15  
 V3 = 25 to 25, V4 = 9 to 25  
 V5 = 25 to 9, V6 = 25 to 15  
 V7 = 37 to 37
- ③ Connector Type: SS = Receptacle to receptacle  
 SP = Receptacle to plug
- ④ Plating Code: A = Selective Gold flash over Nickel  
 \*Optional plating available but MOQ requested
- ⑤ Row Spacing: A: DIM.E = 15.88mm, B: DIM.E = 19.05mm  
 C: DIM.E = 22.86mm
- ⑥ Other Options:  
 C = Riveted ground hooks with #4-40 UNC open (Standard)  
 S = Riveted ground hooks pre-loaded #4-40 UNC Hex screws  
 \*Special options consult manufacturer

**CD71 Series Machined Contact Solder Cup D-Sub**

- ⊙ Mate with standard D-Sub
- ⊙ With metal shell and solder tails
- ⊙ Riveted Hex nuts or hardware accessories options available

RoHS Compliant 

**Plug Connector(00Type)**

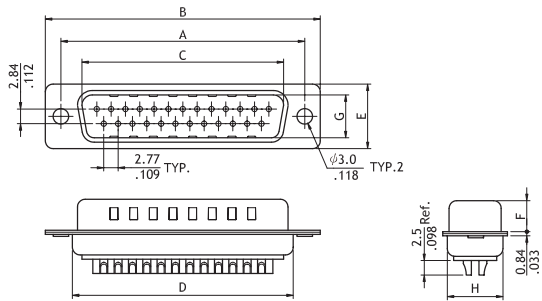

**Receptacle Connector(00Type)**

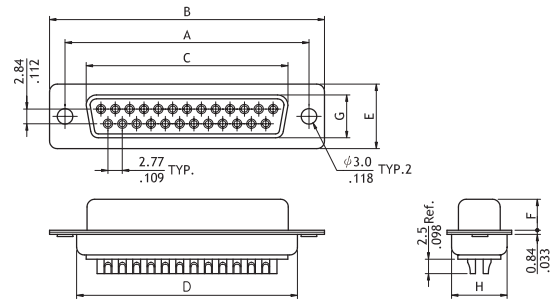

**Plug Connector(A0/A1Type)**

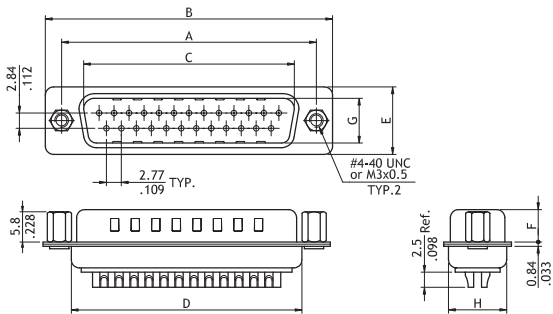

**Receptacle Connector(A0/A1Type)**

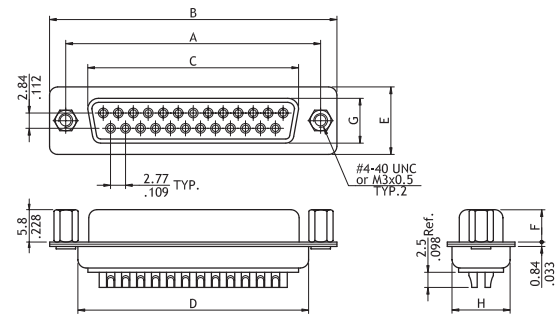

**Plug Connector(B0/B1Type)**

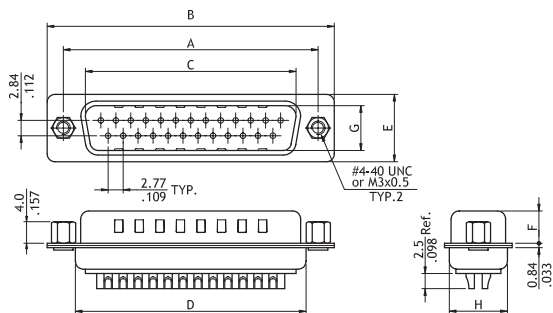

**Receptacle Connector(B0/B1Type)**

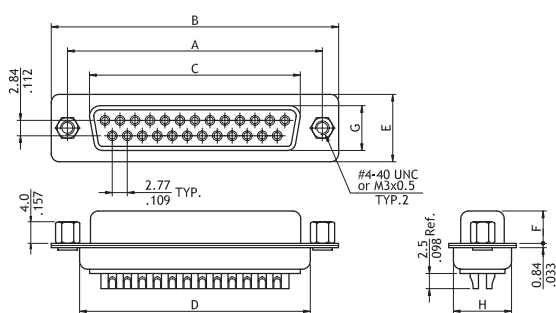

CD

D-SUB CONNECTORS

**CD71 Series Machined Contact Solder Cup D-Sub**

**Plug Connector(C0/C1Type)**

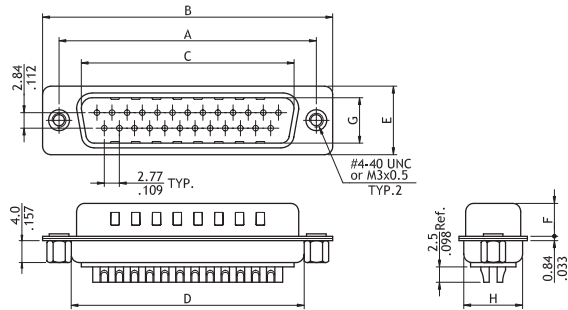

**Receptacle Connector(C0/C1Type)**

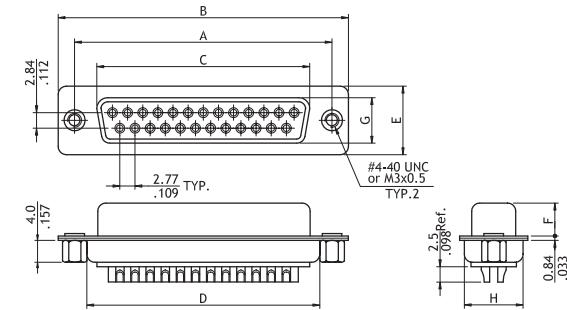

**Plug Connector(K0/K1Type)**

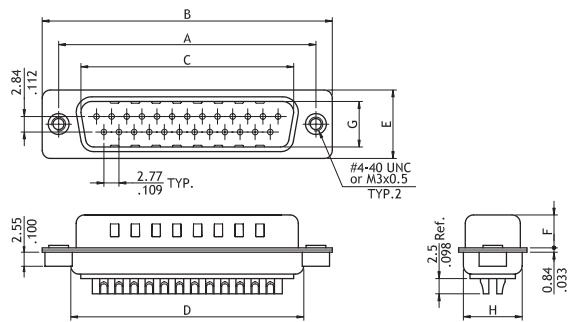

**Receptacle Connector(K0/K1Type)**

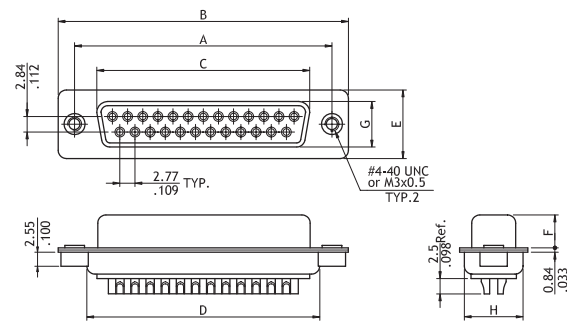

Circuits	Connector Type	Dimension							
		A	B	C	D	E	F	G	H
9	Plug	25.0(.984)	30.8(1.213)	16.92(.666)	19.2(.756)	12.5(.492)	6.0(.236)	8.3(.327)	10.75(.423)
	Receptacle	25.0(.984)	30.8(1.213)	16.30(.642)	19.2(.756)	12.5(.492)	5.8(.228)	7.9(.311)	10.75(.423)
15	Plug	33.32(1.312)	39.2(1.543)	25.25(.994)	27.6(1.087)	12.5(.492)	6.0(.236)	8.3(.327)	10.75(.423)
	Receptacle	33.32(1.312)	39.2(1.543)	24.6(.969)	27.6(1.087)	12.5(.492)	5.8(.228)	7.9(.311)	10.75(.423)
25	Plug	47.04(1.852)	53.1(2.091)	38.96(1.534)	41.1(1.618)	12.5(.492)	6.0(.236)	8.3(.327)	10.75(.423)
	Receptacle	47.04(1.852)	53.1(2.091)	38.3(1.508)	41.1(1.618)	12.5(.492)	5.8(.228)	7.9(.311)	10.75(.423)
37	Plug	63.5(2.500)	69.4(2.732)	55.42(2.182)	57.3(2.256)	12.5(.492)	6.0(.236)	8.3(.327)	10.75(.423)
	Receptacle	63.5(2.500)	69.4(2.732)	54.80(2.157)	57.3(2.256)	12.5(.492)	5.8(.228)	7.9(.311)	10.75(.423)
50	Plug	61.0(2.242)	69.4(2.732)	52.81(2.079)	55.0(2.169)	15.3(.602)	6.0(.236)	11.1(.473)	13.35(.526)
	Receptacle	61.0(2.242)	69.4(2.732)	52.2(2.055)	55.0(2.169)	15.3(.602)	5.8(.228)	10.9(.429)	13.35(.526)

**Ordering Code**

① ② ③ ④ ⑤ ⑥  
**CD71 25 P 2 1 00**

- ① Series No.
- ② No. of Circuits: 09, 15, 25, 37, 50
- ③ Connector Type: P = Plug (Male)  
S = Receptacle (Female)
- ④ Plating Code: 2 = Gold flash over Nickel  
\*Optional plating available but MOQ requested
- ⑤ Insulator Color: 1 = Black  
\*Optional insulator color consult manufacturer

- ⑥ Other Options:  
 00 = With  $\phi$  3.0mm holes on shell (Standard)  
 A0 = Riveted #4-40 UNC Close nuts on Front shell  
 A1 = Riveted M3x0.5 Close nuts on Front shell  
 B0 = Riveted #4-40 UNC Open nuts on Front shell  
 B1 = Riveted M3x0.5 Open nuts on Front shell  
 C0 = Riveted #4-40 UNC Open nuts on Rear shell  
 C1 = Riveted M3x0.5 Open nuts on Rear shell  
 K0 = Riveted #4-40 UNC Open nuts on Rear shell  
 K1 = Riveted M3x0.5 Open nuts on Rear shell  
 \*Special options consult manufacturer

**CD72 Series Machined Contact Straight DIP Solder D-Sub**

- ⊙ Mate with standard D-Sub
- ⊙ With metal shell and solder tails
- ⊙ Riveted Hex nuts or hardware accessories options available

**RoHS** Compliant

**Plug Connector (00Type)**

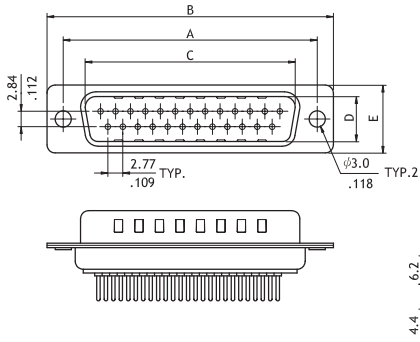

**Receptacle Connector (00Type)**

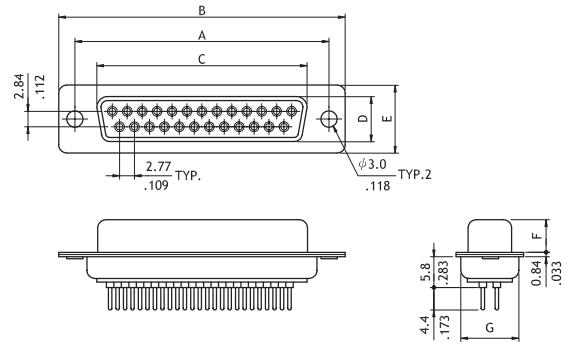

**Plug Connector (A0/A1Type)**

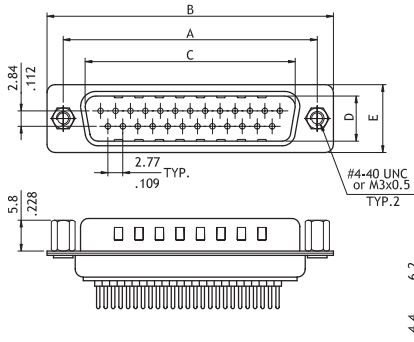

**Receptacle Connector (A0/A1Type)**

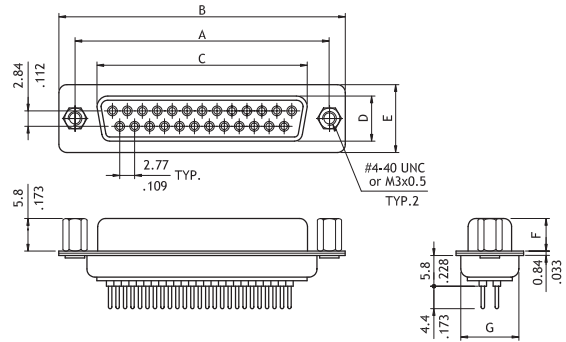

**Plug Connector (B0/B1Type)**

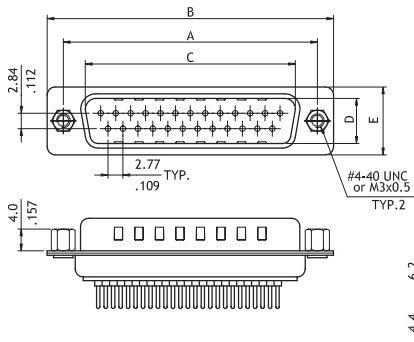

**Receptacle Connector (B0/B1Type)**

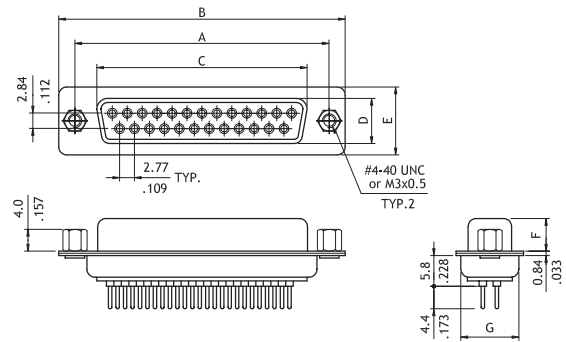

CD

D-SUB CONNECTORS

**CD72 Series Machined Contact Straight DIP Solder D-Sub**

**Plug Connector (C0/C1 Type)**

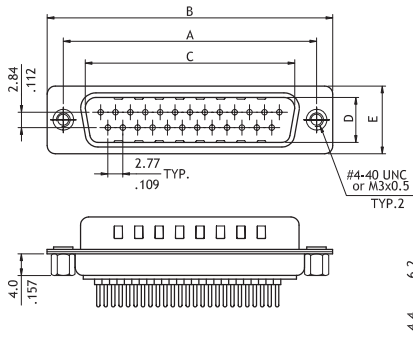

**Receptacle Connector (C0/C1 Type)**

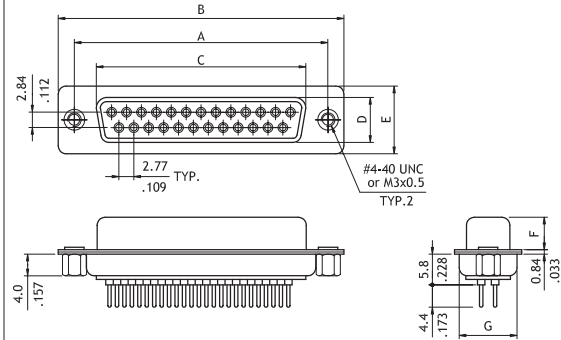

**Plug Connector (D3/D4 Type)**

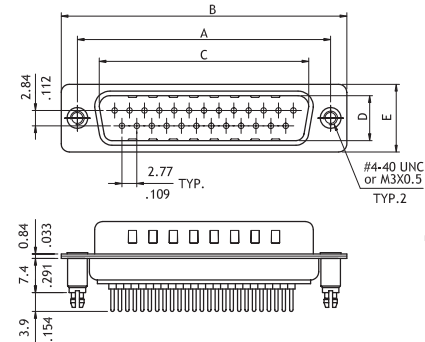

**Receptacle Connector (D3/D4 Type)**

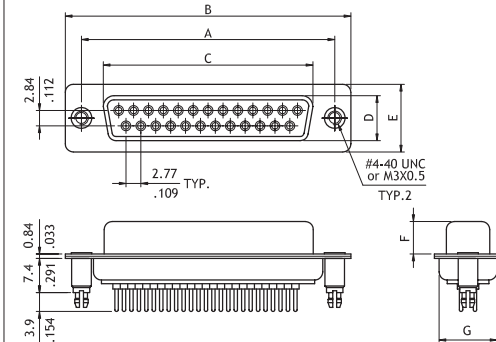

Circuits	Connector Type	Dimension						
		A	B	C	D	E	F	G
9	Plug	25.0(.984)	30.8(1.213)	16.92(.666)	8.3(.327)	12.5(.492)	6.0(.236)	10.75(.423)
	Receptacle	25.0(.984)	30.8(1.213)	16.3(.642)	7.9(.311)	12.5(.492)	5.8(.228)	10.75(.423)
15	Plug	33.32(1.312)	39.2(1.543)	25.25(.994)	8.3(.327)	12.5(.492)	6.0(.236)	10.75(.423)
	Receptacle	33.32(1.312)	39.2(1.543)	24.6(.969)	7.9(.311)	12.5(.492)	5.8(.228)	10.75(.423)
25	Plug	47.04(1.852)	53.1(2.091)	38.96(1.534)	8.3(.327)	12.5(.492)	6.0(.236)	10.75(.423)
	Receptacle	47.04(1.852)	53.1(2.091)	38.3(1.508)	7.9(.311)	12.5(.492)	5.8(.228)	10.75(.423)
37	Plug	63.5(2.500)	69.4(2.732)	55.42(2.182)	8.3(.327)	12.5(.492)	6.0(.236)	10.75(.423)
	Receptacle	63.5(2.500)	69.4(2.732)	54.8(2.157)	7.9(.311)	12.5(.492)	5.8(.228)	10.75(.423)
50	Plug	61.0(2.402)	67.0(2.638)	52.8(2.079)	11.1(.473)	15.3(.602)	6.0(.236)	13.35(.526)
	Receptacle	61.0(2.402)	67.0(2.638)	52.2(2.055)	10.9(.429)	15.3(.602)	5.8(.228)	13.55(.526)

**Ordering Code**

① ② ③ ④ ⑤ ⑥  
**CD72 25 P 2 1 00**

- ① Series No.
- ② No. of Circuits: 09, 15, 25, 37, 50
- ③ Connector Type: P = Plug (Male)  
S = Receptacle (Female)
- ④ Plating Code: 2 = Gold flash over Nickel  
\*Optional plating available but MOQ requested
- ⑤ Insulator Color: 1 = Black  
\*Optional insulator color consult manufacturer

- ⑥ Other Options:  
 00 = With  $\phi$  3.0mm holes on shell (Standard)  
 A0 = Riveted #4-40 UNC Close nuts on Front shell  
 A1 = Riveted M3x0.5 Close nuts on Front shell  
 B0 = Riveted #4-40 UNC Open nuts on Front shell  
 B1 = Riveted M3x0.5 Open nuts on Front shell  
 C0 = Riveted #4-40 UNC Open nuts on Rear shell  
 C1 = Riveted M3x0.5 Open nuts on Rear shell  
 D3 = Riveted #4-40 UNC Close ground stand-off on Rear shell  
 D4 = Riveted M3x0.5 Close ground stand-off on Rear shell  
 \*Special options consult manufacturer

CD

D-SUB CONNECTORS

**CD73 Series 8.10mm Footprint Right Angle DIP Solder D-Sub**

- ⊙ Machined contact with right angle solder tails
- ⊙ Mate with standard D-Sub
- ⊙ Metal shell and solder tails
- ⊙ Riveted Hex nuts or hardware accessories options available

RoHS Compliant 

Plug Connector(00Type)

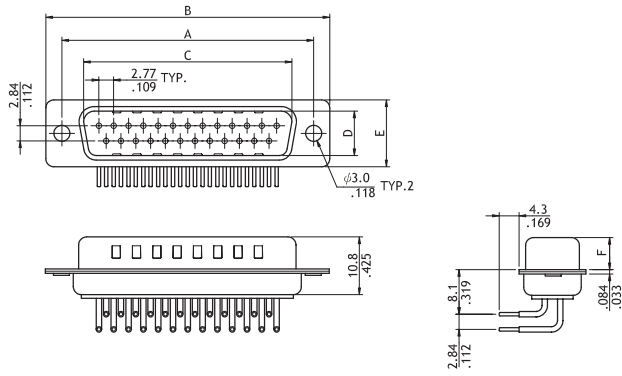

Receptacle Connector(00Type)

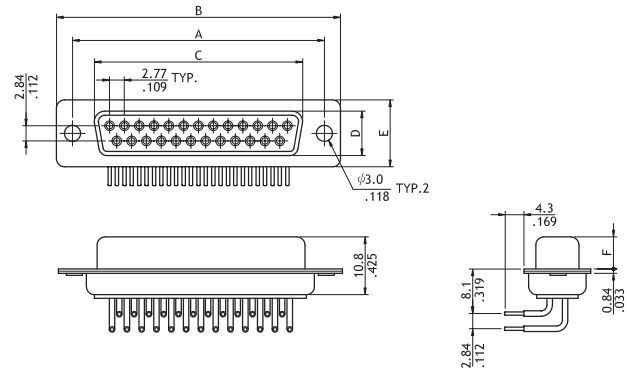

Plug Connector(I0/I2Type)

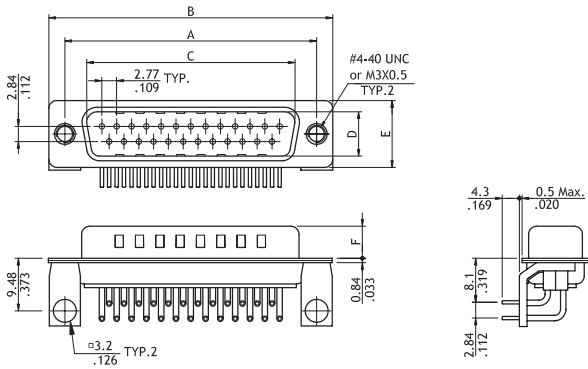

Receptacle Connector(I0/I2Type)

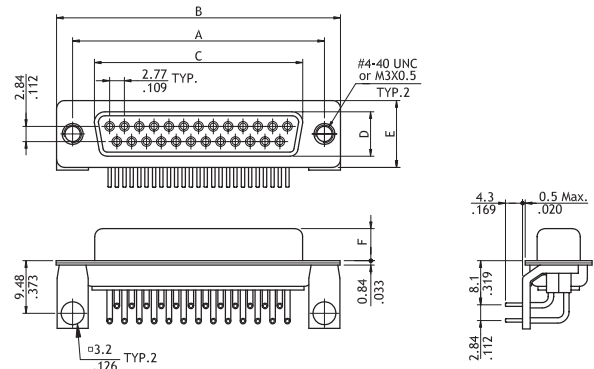

CD



## Combo D-Sub Technical Specifications

- ◎ The connectors conform to MIL-24308(DIN 41652) cad the shell dimensions are the same as standard D-sub connectors so that mating is no problem
- ◎ Test methods for electronic connector are according to MILITARY standard MIL-STD-1344A and MILSTD-202F

## Construction

### Connector Assemblies -

- Shell : Steel, Tin Plated as Standard
- Insulator : Glass filled polyester UL 94V-0  
Color Black or Green
- Signal Contact when applicable :  
Copper alloy : Please see ordering code for plating options
- Standoff : Copper alloy, Tin over Copper
- Bracket : Steel, Nickel plated
- Rivnut : Copper alloy, Nickel plated
- Locking Clipper : Copper alloy, Tin over Copper

### Coaxial Contact Assembly -

- Insulator : Teflon UL 94V-0, Color White
- Center and outside contact : Copper alloy  
Please see ordering code for plating options
- Lock link : Copper alloy, Tin plated over Nickel

### High Power Contact Assembly -

- Contact : Copper alloy  
Please see ordering code for plating options
- Lock link : Copper alloy, Tin plated over Nickel

## Performance Data

- Signal contact current rating : 3 Amps
- Signal contact resistance : < 10 mΩ
- Dielectric withstanding Voltage: 1000VAC for one minute at sea level
- Insulation Resistance : > 5000 MΩ
- Coaxial Contact impedance : 75Ω or 50Ω
- High power contact current rating : 40 or 20 Amps
- High power contact Resistance : < 2.7 m
- Connector mating and unmating force:17.0 kgf max.
- Durability:100 Cycles
- Operating Temperature: -55°~+125°C

## Contact Arrangements

- ⊙ Accommodated removable Coaxial and high power contacts
- ⊙ The product indicated “◆” Not available at present

	◆					◆
Contact Arrangement	5W1	3W3	7W2	11W1	5W5	9W4
Shell Size	E	A	A	A	B	B
No. of Signal Contacts	4	0	5	10	0	5
No. of Coaxial Contacts	1	3	2	1	5	4
	◆			◆		
Contact Arrangement	13W3	17W2	21W1	8W8		
Shell Size	B	B	B	C		
No. of Signal Contacts	10	15	20	0		
No. of Coaxial Contacts	3	2	1	8		
	◆		◆			
Contact Arrangement	13W6	17W5	21W4			
Shell Size	C	C	C			
No. of Signal Contacts	7	12	17			
No. of Coaxial Contacts	6	5	4			
	◆		◆		◆	
Contact Arrangement	25W3	27W2	24W7			
Shell Size	C	C	D			
No. of Signal Contacts	22	25	17			
No. of Coaxial Contacts	3	2	7			
	◆		◆		◆	
Contact Arrangement	36W4	43W2	47W1			
Shell Size	D	D	D			
No. of Signal Contacts	32	41	46			
No. of Coaxial Contacts	4	2	1			

## Mounting Style Options

0	Riveted front and rear shell with 3.05mm Hole	A	Riveted #4-40 UNC close nuts on front shell DIM L=5.8mm (Standard)	B	Riveted #4-40 UNC open nuts on front shell DIM L=4.0mm (Standard)
C	Riveted #4-40 UNC open nuts on rear shell DIM. L= 4.0mm (Standard)	D	Riveted #4-40 UNC close ground Stand-off on rear shell DIM L=7.0mm (Standard)	I	Riveted ground tabs with #4-40 UNC open

Coaxial Contact for Combination D-Sub

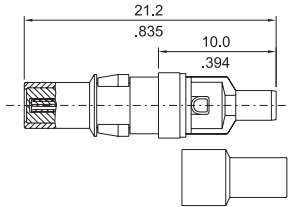
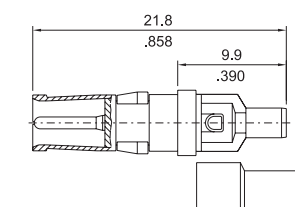
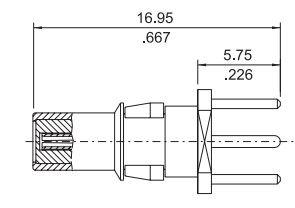
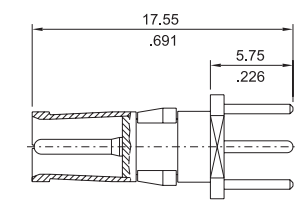
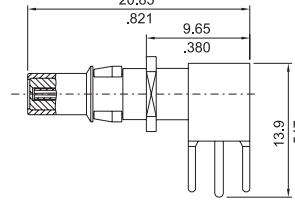
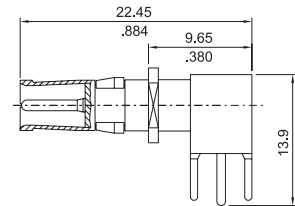
Contact Type	Shape	Part No.	Plating	Impedance	R.G Cable
Solder Cup	 <p>Plug Contact</p>	CXLTPS27500	Gold flash plated over 50µin Nickel	75Ω	179B/U
		CXLTPS37500	15µin Gold plated over 50µin Nickel		
		CXLTPS47500	30µin Gold plated over 50µin Nickel		
		CXLTPS57500	50µin Gold plated over 50µin Nickel		
		CXLTPS25000	Gold flash plated over 50µin Nickel		
		CXLTPS35000	15µin Gold plated over 50µin Nickel		
		CXLTPS45000	30µin Gold plated over 50µin Nickel		
	 <p>Receptacle Contact</p>	CXLTPS55000	50µin Gold plated over 50µin Nickel	50Ω	178B/U
		CXLTSS27500	Gold flash plated over 50µin Nickel		
		CXLTSS37500	15µin Gold plated over 50µin Nickel		
		CXLTSS47500	30µin Gold plated over 50µin Nickel		
		CXLTSS57500	50µin Gold plated over 50µin Nickel		
		CXLTSS25000	Gold flash plated over 50µin Nickel		
		CXLTSS35000	15µin Gold plated over 50µin Nickel		
Straight DIP	 <p>Plug Contact</p>	CXLTPV27500	Gold flash plated over 50µin Nickel	75Ω	—
		CXLTPV37500	15µin Gold plated over 50µin Nickel		
		CXLTPV47500	30µin Gold plated over 50µin Nickel		
		CXLTPV57500	50µin Gold plated over 50µin Nickel		
		CXLTPV25000	Gold flash plated over 50µin Nickel		
		CXLTPV35000	15µin Gold plated over 50µin Nickel		
		CXLTPV45000	30µin Gold plated over 50µin Nickel		
	 <p>Receptacle Contact</p>	CXLTPV55000	50µin Gold plated over 50µin Nickel	50Ω	—
		CXLTSV27500	Gold flash plated over 50µin Nickel		
		CXLTSV37500	15µin Gold plated over 50µin Nickel		
		CXLTSV47500	30µin Gold plated over 50µin Nickel		
		CXLTSV57500	50µin Gold plated over 50µin Nickel		
		CXLTSV25000	Gold flash plated over 50µin Nickel		
		CXLTSV35000	15µin Gold plated over 50µin Nickel		
Right Angle DIP	 <p>Plug Contact</p>	CXLTPH27500	Gold flash plated over 50µin Nickel	75Ω	—
		CXLTPH37500	15µin Gold plated over 50µin Nickel		
		CXLTPH47500	30µin Gold plated over 50µin Nickel		
		CXLTPH57500	50µin Gold plated over 50µin Nickel		
		CXLTPH25000	Gold flash plated over 50µin Nickel		
		CXLTPH35000	15µin Gold plated over 50µin Nickel		
		CXLTPH45000	30µin Gold plated over 50µin Nickel		
	 <p>Receptacle Contact</p>	CXLTPH55000	50µin Gold plated over 50µin Nickel	50Ω	—
		CXLTSH27500	Gold flash plated over 50µin Nickel		
		CXLTSH37500	15µin Gold plated over 50µin Nickel		
		CXLTSH47500	30µin Gold plated over 50µin Nickel		
		CXLTSH57500	50µin Gold plated over 50µin Nickel		
		CXLTSH25000	Gold flash plated over 50µin Nickel		
		CXLTSH35000	15µin Gold plated over 50µin Nickel		
CXLTSH45000	30µin Gold plated over 50µin Nickel				
CXLTSH55000	50µin Gold plated over 50µin Nickel				

**High Power Contact for Combination D-Sub**

Contact Type	Shape	Part No.	Plating	Current Rating	Wire Size
Solder Cup	<p>Plug Contact</p>	CHPTPS22000	Gold flash plated over 50µin Nickel	20A	AWG #12~#14
		CHPTPS32000	15µin Gold plated over 50µin Nickel		
		CHPTPS42000	30µin Gold plated over 50µin Nickel		
		CHPTPS52000	50µin Gold plated over 50µin Nickel		
		CHPTPS24000	Gold flash plated over 50µin Nickel		
		CHPTPS34000	15µin Gold plated over 50µin Nickel		
		CHPTPS44000	30µin Gold plated over 50µin Nickel		
	<p>Receptacle Contact</p>	CHPTSS22000	Gold flash plated over 50µin Nickel	20A	AWG #12~#14
		CHPTSS32000	15µin Gold plated over 50µin Nickel		
		CHPTSS42000	30µin Gold plated over 50µin Nickel		
		CHPTSS52000	50µin Gold plated over 50µin Nickel		
		CHPTSS24000	Gold flash plated over 50µin Nickel		
		CHPTSS34000	15µin Gold plated over 50µin Nickel		
		CHPTSS44000	30µin Gold plated over 50µin Nickel		
Crimp Type	<p>Plug Contact</p>	CHPTPC22000	Gold flash plated over 50µin Nickel	20A	AWG #12~#14
		CHPTPC32000	15µin Gold plated over 50µin Nickel		
		CHPTPC42000	30µin Gold plated over 50µin Nickel		
		CHPTPC52000	50µin Gold plated over 50µin Nickel		
		CHPTPC24000	Gold flash plated over 50µin Nickel		
		CHPTPC34000	15µin Gold plated over 50µin Nickel		
		CHPTPC44000	30µin Gold plated over 50µin Nickel		
	<p>Receptacle Contact</p>	CHPTSC22000	Gold flash plated over 50µin Nickel	20A	AWG #12~#14
		CHPTSC32000	15µin Gold plated over 50µin Nickel		
		CHPTSC42000	30µin Gold plated over 50µin Nickel		
		CHPTSC52000	50µin Gold plated over 50µin Nickel		
		CHPTSC24000	Gold flash plated over 50µin Nickel		
		CHPTSC34000	15µin Gold plated over 50µin Nickel		
		CHPTSC44000	30µin Gold plated over 50µin Nickel		
CHPTSC54000	50µin Gold plated over 50µin Nickel				

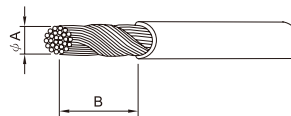
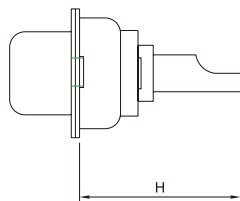

Current Rating	Crimp and Solder Terminations			
	DIM. φ A min.	DIM. φ A max.	DIM. B	DIM. H max.
20A	1.8(.071)	2.6(.102)	8.0(.315)~	16.5(.650)
40A	2.9(.114)	4.5(.177)	8.8(.346)	

CD

D-SUB CONNECTORS

**High Power Contact for Combination D-Sub**

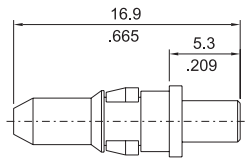
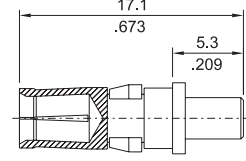
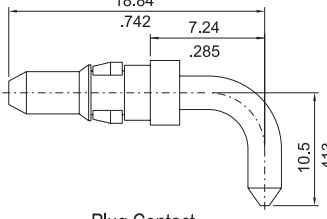
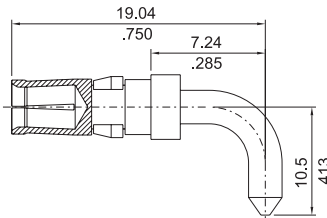
Contact Type	Shape	Part No.	Plating	Current Rating	
Straight DIP	 <p>Plug Contact</p>	CHPTPV22000	Gold flash plated over 50µin Nickel	20A	
		CHPTPV32000	15µin Gold plated over 50µin Nickel		
		CHPTPV42000	30µin Gold plated over 50µin Nickel		
		CHPTPV52000	50µin Gold plated over 50µin Nickel		
		CHPTPV24000	Gold flash plated over 50µin Nickel		
		CHPTPV34000	15µin Gold plated over 50µin Nickel		
		CHPTPV44000	30µin Gold plated over 50µin Nickel		
	CHPTPV54000	50µin Gold plated over 50µin Nickel	40A		
	 <p>Receptacle Contact</p>	CHPTSV22000		Gold flash plated over 50µin Nickel	20A
		CHPTSV32000		15µin Gold plated over 50µin Nickel	
		CHPTSV42000		30µin Gold plated over 50µin Nickel	
		CHPTSV52000		50µin Gold plated over 50µin Nickel	
		CHPTSV24000		Gold flash plated over 50µin Nickel	
		CHPTSV34000		15µin Gold plated over 50µin Nickel	
CHPTSV44000		30µin Gold plated over 50µin Nickel			
CHPTSV54000	50µin Gold plated over 50µin Nickel	40A			
Right Angle DIP	 <p>Plug Contact</p>		CHPTPH22000	Gold flash plated over 50µin Nickel	20A
			CHPTPH32000	15µin Gold plated over 50µin Nickel	
			CHPTPH42000	30µin Gold plated over 50µin Nickel	
			CHPTPH52000	50µin Gold plated over 50µin Nickel	
			CHPTPH24000	Gold flash plated over 50µin Nickel	
			CHPTPH34000	15µin Gold plated over 50µin Nickel	
		CHPTPH44000	30µin Gold plated over 50µin Nickel		
	CHPTPH54000	50µin Gold plated over 50µin Nickel	40A		
	 <p>Receptacle Contact</p>	CHPTSH22000		Gold flash plated over 50µin Nickel	20A
		CHPTSH32000		15µin Gold plated over 50µin Nickel	
		CHPTSH42000		30µin Gold plated over 50µin Nickel	
		CHPTSH52000		50µin Gold plated over 50µin Nickel	
		CHPTSH24000		Gold flash plated over 50µin Nickel	
		CHPTSH34000		15µin Gold plated over 50µin Nickel	
CHPTSH44000		30µin Gold plated over 50µin Nickel			
CHPTSH54000	50µin Gold plated over 50µin Nickel	40A			

CD

P/N CD-RWT-0100

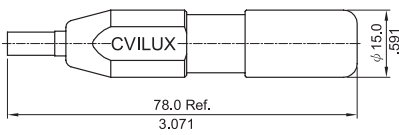

The COMBO D-SUB EXTRACTOR.  
It is used in Coaxial or High power contact.  
(available for male/female )

Step 1

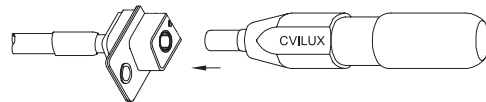

Step 2

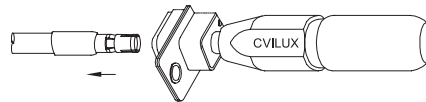

Step 3

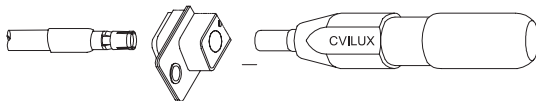

## Combination D-Sub Housing

- ⊙ Pre-loaded stamped signal contact
- ⊙ Can be mated with coaxial or high power contact
- ⊙ High power contact available for crimp or solder type in 20A or 40A
- ⊙ Metal shell with ground indents
- ⊙ Riveted Hex nuts or hardware accessories options available

RoHS Compliant

C3W3 (Plug Connector)

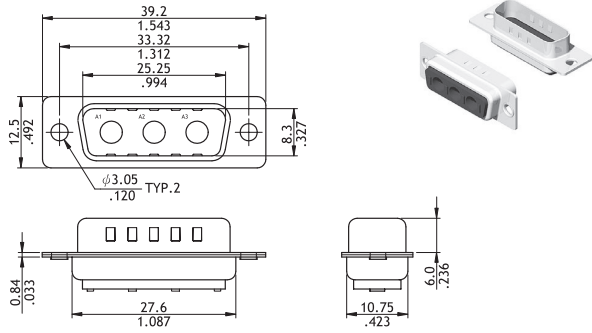

C3W3 (Receptacle Connector)

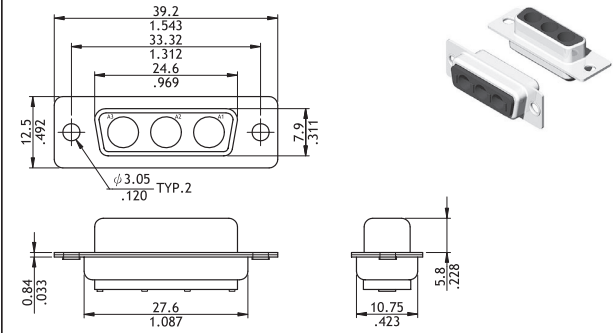

3W3C (Plug Connector)

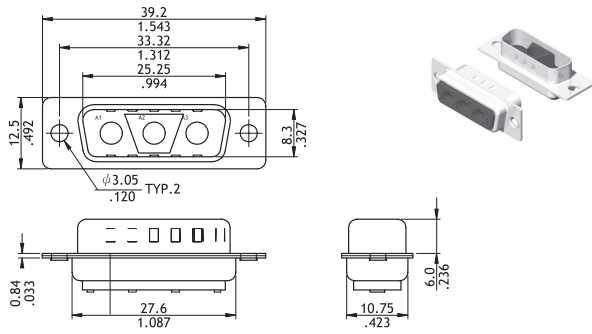

3W3C (Receptacle Connector)

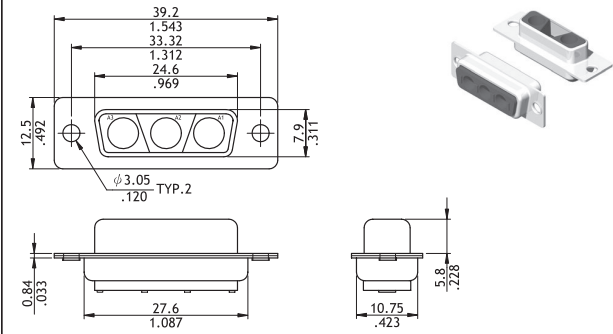

C7W2 (Plug Connector)

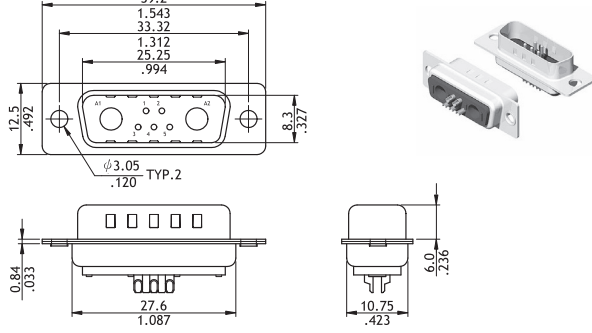

C7W2 (Receptacle Connector)

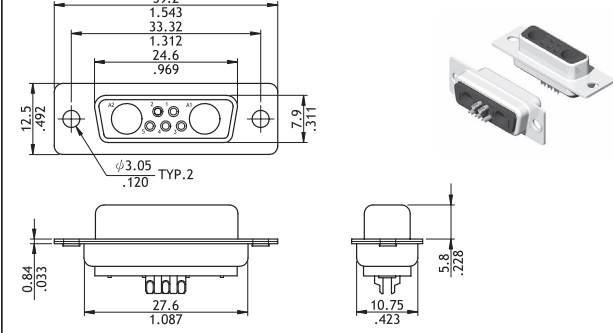

11W1 (Plug Connector)

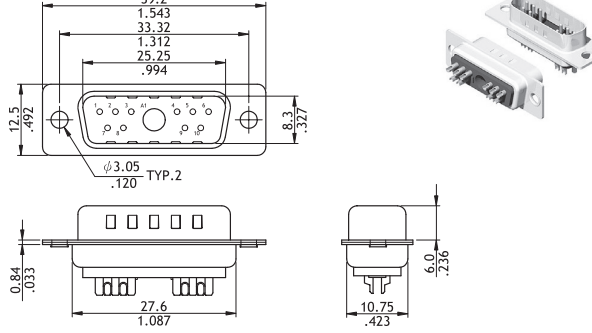

11W1 (Receptacle Connector)

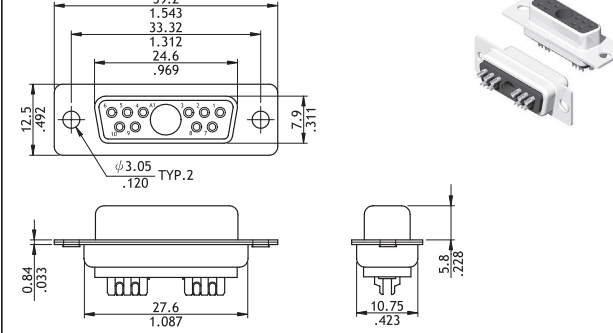

CD

D-SUB CONNECTORS

**Combination D-Sub Housing**

**C5W5 (Plug Connector)**

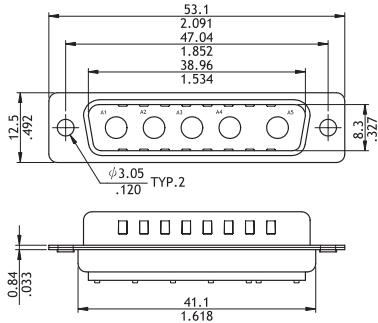

**C5W5 (Receptacle Connector)**

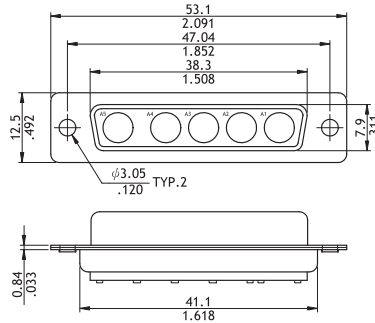

**13W3 (Plug Connector)**

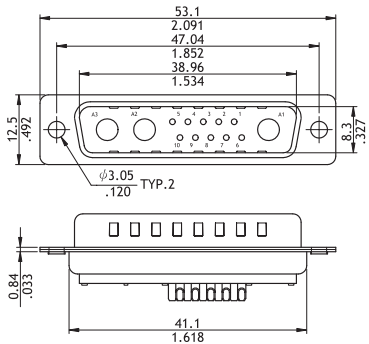

**13W3 (Receptacle Connector)**

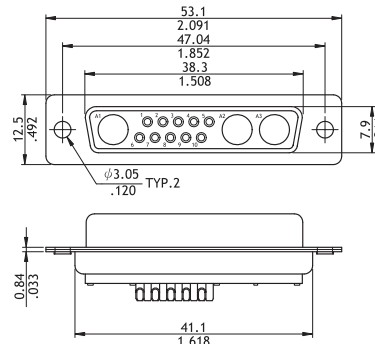

**17W2 (Plug Connector)**

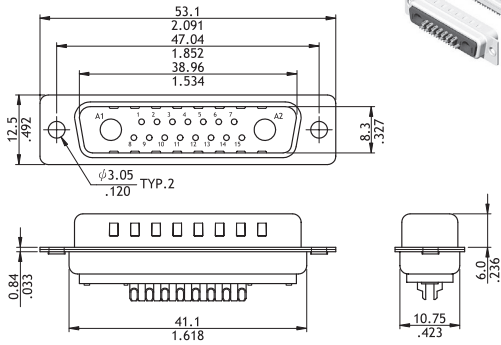

**17W2 (Receptacle Connector)**

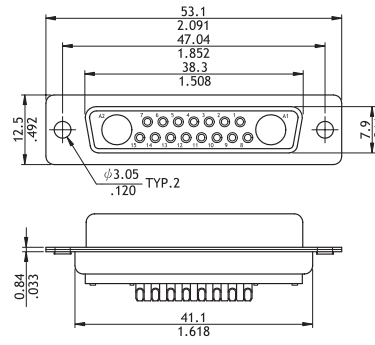

**C8W8 (Plug Connector)**

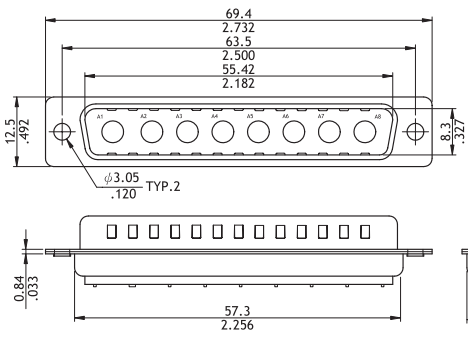

**C8W8 (Receptacle Connector)**

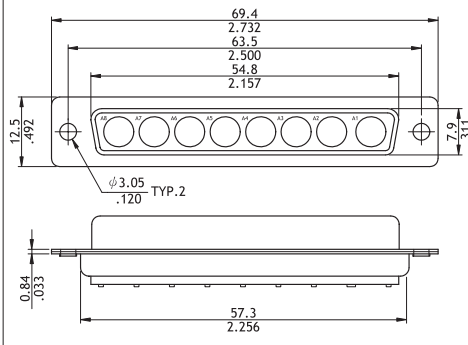

CD

D-SUB CONNECTORS

## Combination D-Sub Housing

21W4 (Plug Connector)

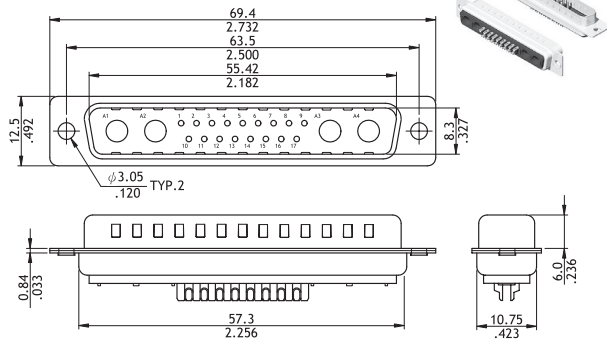

21W4 (Receptacle Connector)

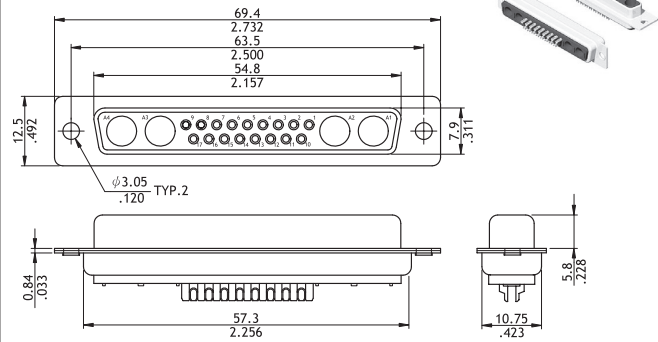

25W3 (Plug Connector)

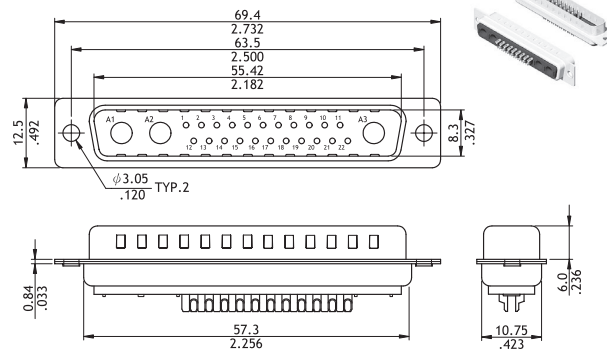

25W3 (Receptacle Connector)

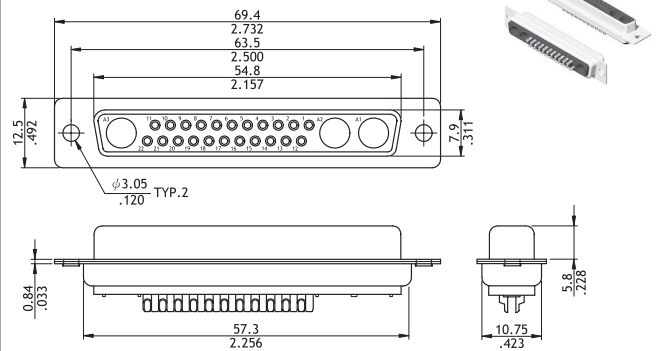

36W4 (Plug Connector)

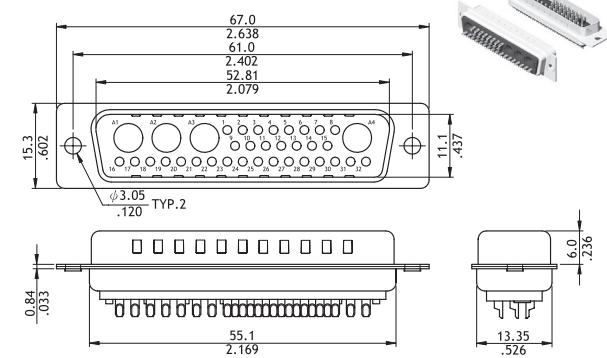

36W4 (Receptacle Connector)

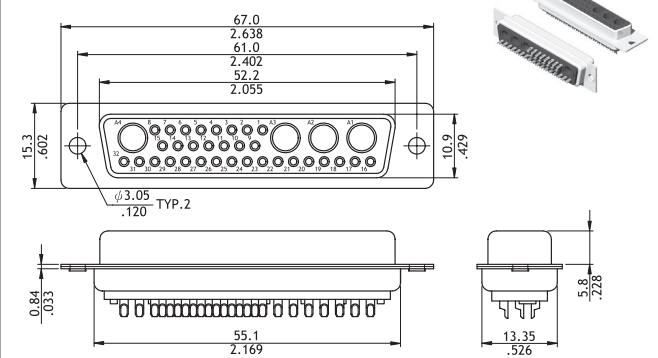

### Ordering Code

① ② ③ ④ ⑤ ⑥  
**13W3 P0 S0 A 100 000**

- ① Series No.: C3W3, 3W3C, C7W2, 11W1, C5W5, 13W3, 17W3, C8W8, 21W4, 25W3, 36W4
- ② Connector Type: P0 = Plug  
S0 = Receptacle
- ③ Contact Tail: S0= Solder Cup Type (C3W3, C5W5, 3W3C, C8W8 Series, Code= 00)
- ④ Signal Contact Plating:  
A = Selective Gold flash over Nickel  
0 = Without Signal Contact

- ⑤ Insulator Color: 100 = Black
- ⑥ Other Options:  
000 = With  $\phi 3.05$ mm holes on shell (Standard)  
A00= Riveted #4-40 UNC Close nuts on Front shell  
B00= Riveted #4-40 UNC Open nuts on Front shell  
C00= Riveted #4-40 UNC Open nuts on Rear shell  
\*Special options consult manufacturer  
Connectors and coaxial/high power contacts should be ordered respectively to confirm production process

**Coaxial Straight DIP Combination D-Sub**

- ⊙ Standard type with #4-40 UNC threaded ground stand-off
- ⊙ Combined with stamped signal and machined coaxial contacts
- ⊙ For top entry connection
- ⊙ Metal shell with ground indents
- ⊙ Riveted Hex nuts or hardware accessories options available



**C3W3 (Plug Connector)**

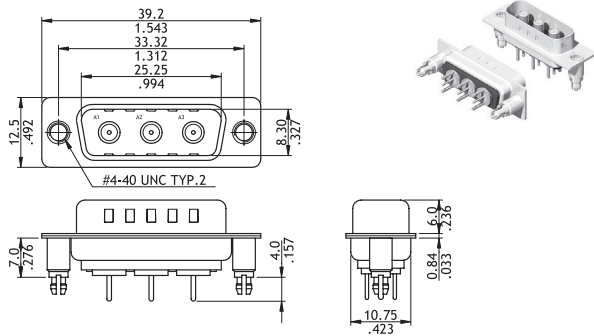

**C3W3 (Receptacle Connector)**

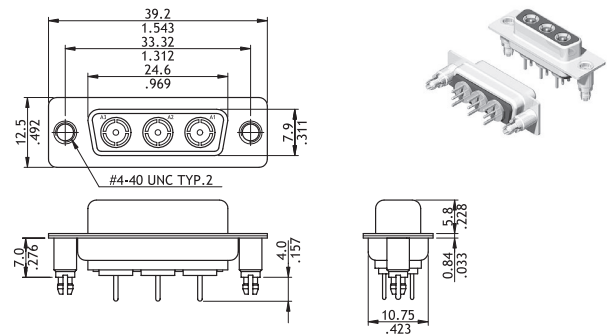

**3W3C (Plug Connector)**

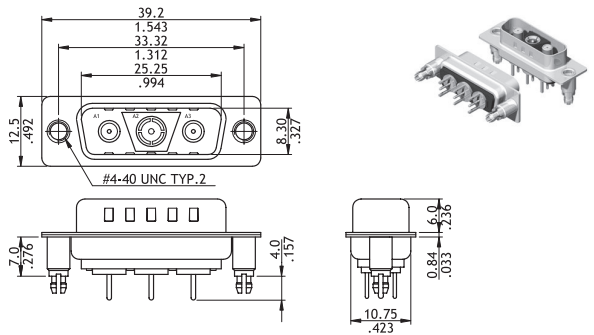

**3W3C (Receptacle Connector)**

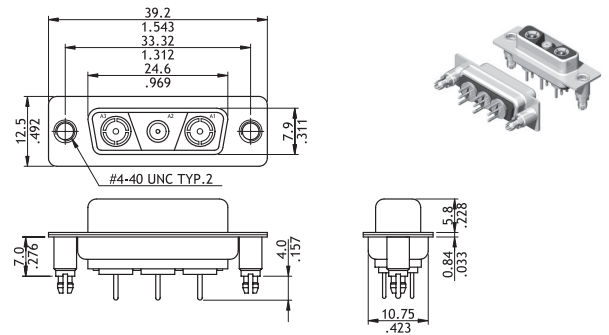

**C7W2 (Plug Connector)**

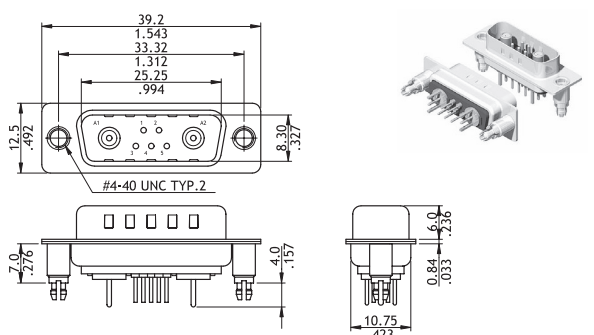

**C7W2 (Receptacle Connector)**

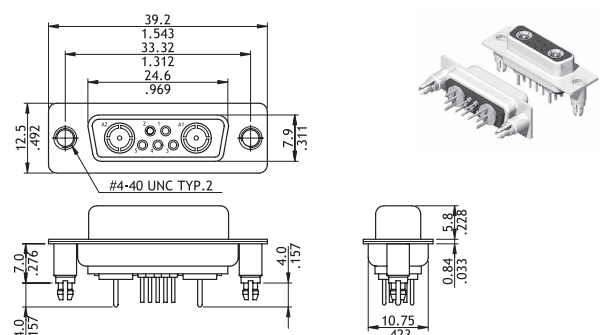

**11W1 (Plug Connector)**

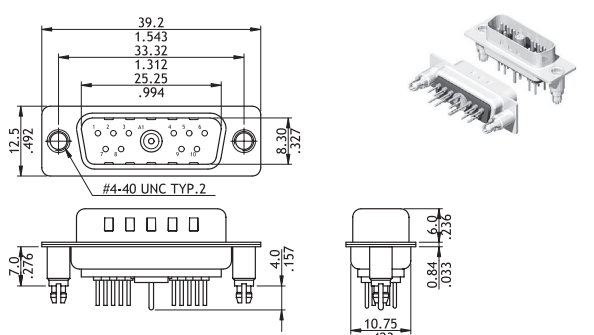

**11W1 (Receptacle Connector)**

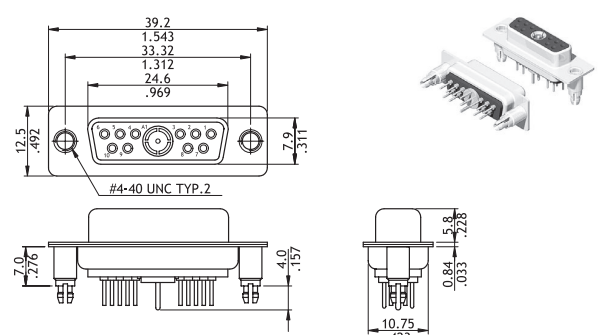

CD

D-SUB CONNECTORS

**Coaxial Straight DIP Combination D-Sub**

C5W5 (Plug Connector)

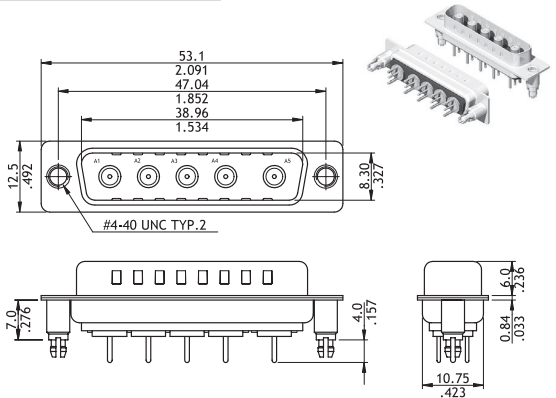

C5W5 (Receptacle Connector)

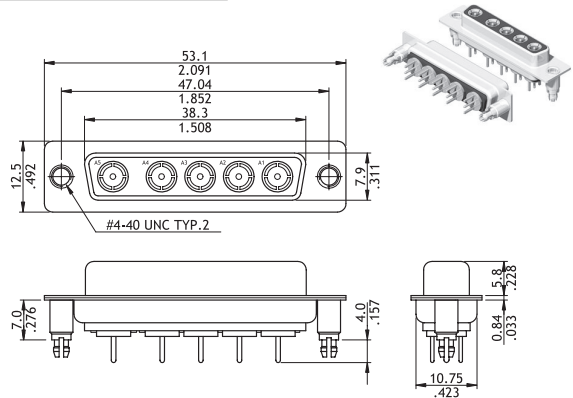

13W3 (Plug Connector)

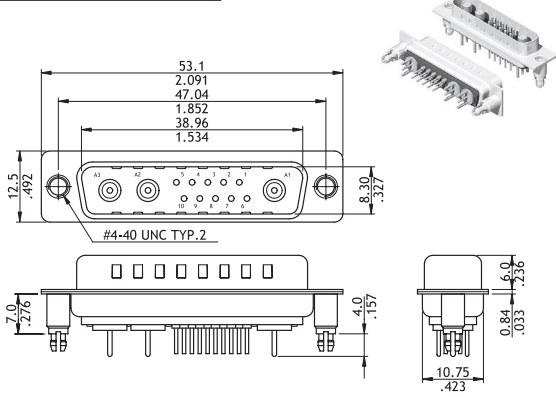

13W3 (Receptacle Connector)

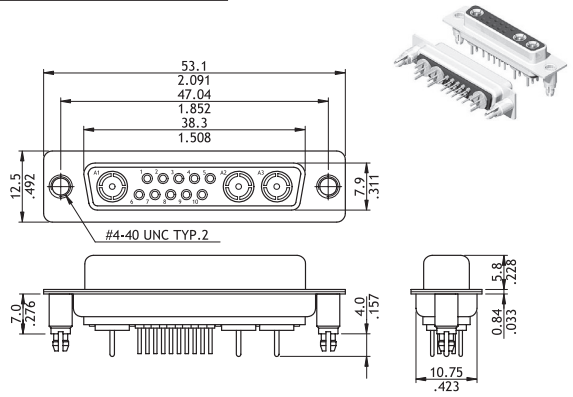

17W2 (Plug Connector)

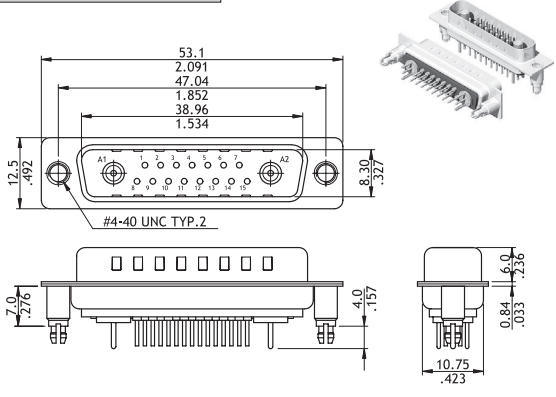

17W2 (Receptacle Connector)

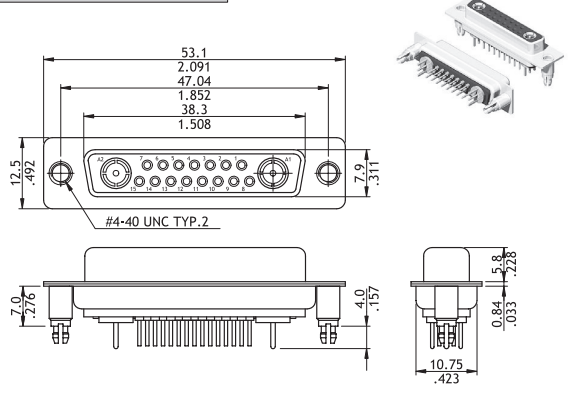

C8W8 (Plug Connector)

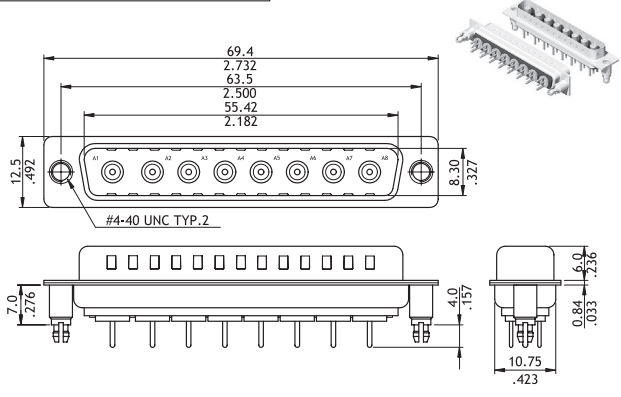

C8W8 (Receptacle Connector)

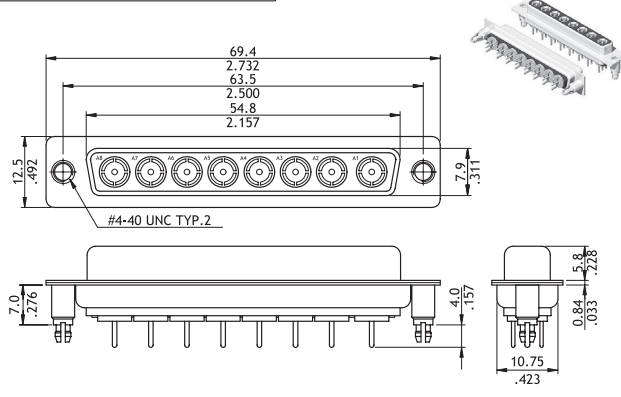

CD

D-SUB CONNECTORS

Coaxial Straight DIP Combination D-Sub

21W4 (Plug Connector)

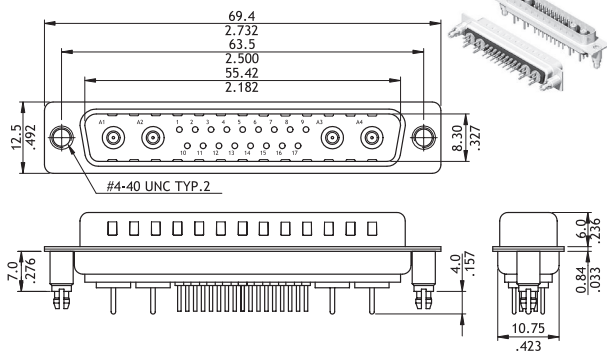

21W4 (Receptacle Connector)

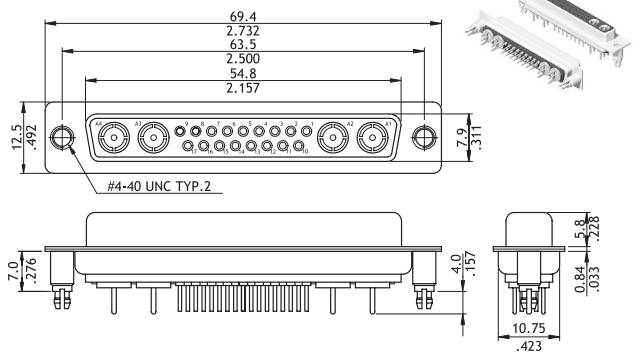

25W3 (Plug Connector)

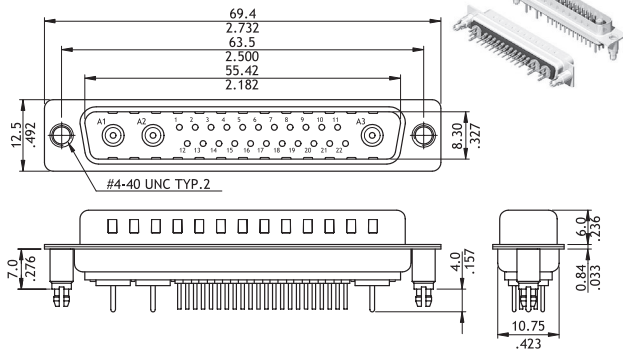

25W3 (Receptacle Connector)

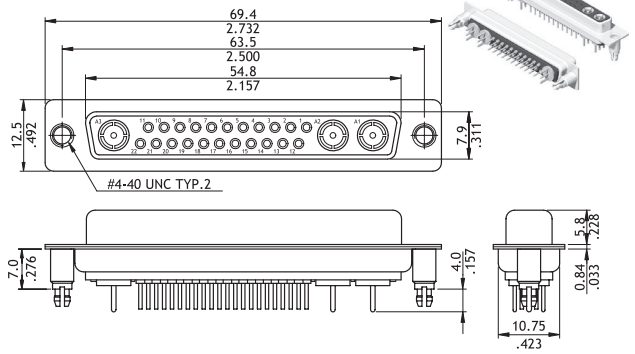

36W4 (Plug Connector)

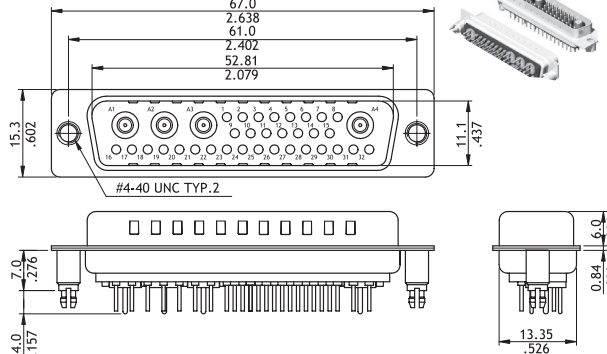

36W4 (Receptacle Connector)

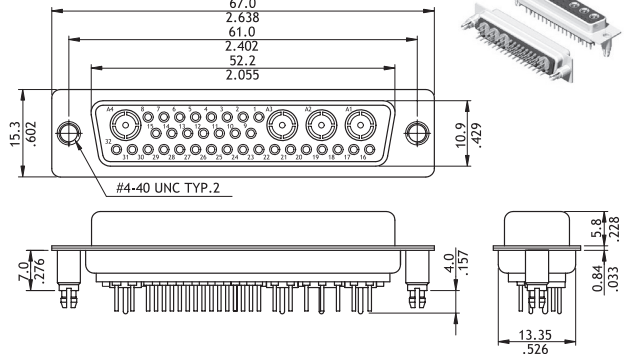

Ordering Code

① ② ③ ④ ⑤ ⑥ ⑦ ⑧ ⑨  
**13W3 S C V 2 2 1 75 D00**

- ① Series No.: C3W3, 3W3C, C7W2, 11W1, C5W5, 13W3, 17W3, C8W8, 21W4, 25W3, 36W4
- ② Connector Type: P = Plug  
S = Receptacle
- ③ Contact Type: C = Coaxial Contact
- ④ Contact Tail Style: V = Straight DIP Type
- ⑤ Coaxial Contact Plating: 2 = Gold flash over Nickel
- ⑥ Signal Contact Plating: 2 = Gold flash over Nickel  
0 = Without Signal Contact

- ⑦ Insulator Color: 1 = Black
- ⑧ Performance: 50 = 50Ω, 75 = 75Ω
- ⑨ Mounting Style:  
000 = With  $\phi$  3.05mm holes on shell (Standard)  
A00 = Riveted #4-40 UNC Close nuts on Front shell  
B00 = Riveted #4-40 UNC Open nuts on Front shell  
C00 = Riveted #4-40 UNC Open nuts on Rear shell  
D00 = Riveted #4-40 UNC Ground Stand-off  
\*Special options consult manufacturer

CD

D-SUB CONNECTORS

## Coaxial Right Angle DIP Combination D-Sub

- ⊙ Standard type with #4-40 UNC threaded ground stand tabs and board locks to secure connector on board
- ⊙ Combined with stamped signal and machined coaxial contacts
- ⊙ For side entry connection
- ⊙ Metal shell with ground indents
- ⊙ Riveted Hex nuts or hardware accessories options available

RoHS Compliant

C3W3 (Plug Connector)

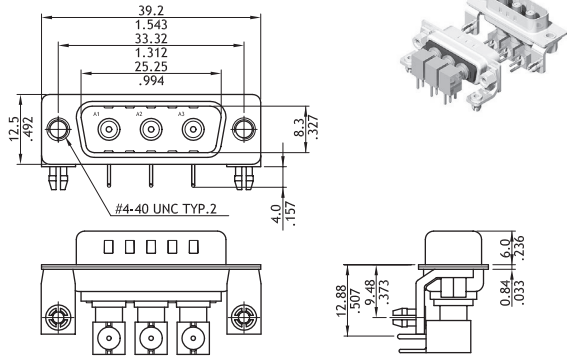

C3W3 (Receptacle Connector)

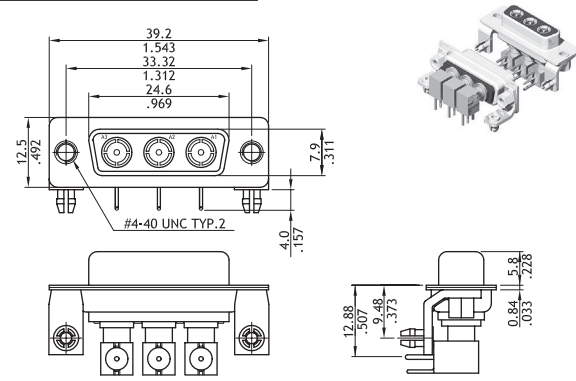

3W3C (Plug Connector)

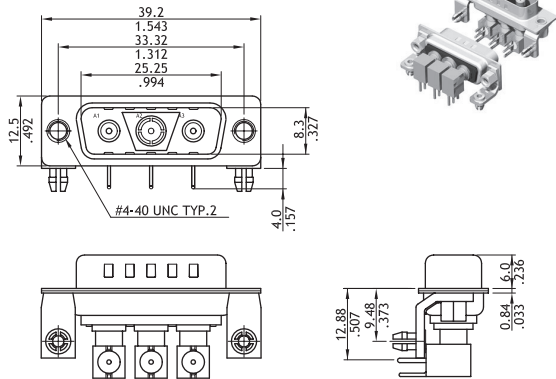

3W3C (Receptacle Connector)

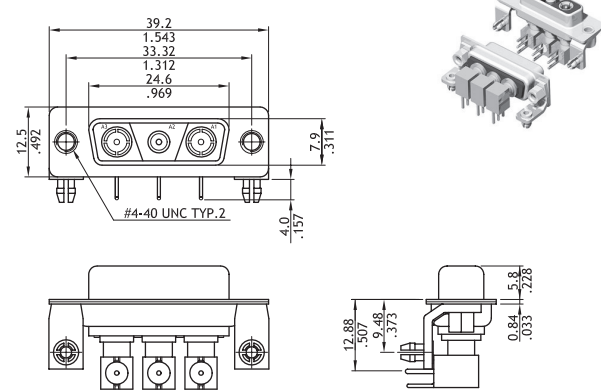

C7W2 (Plug Connector)

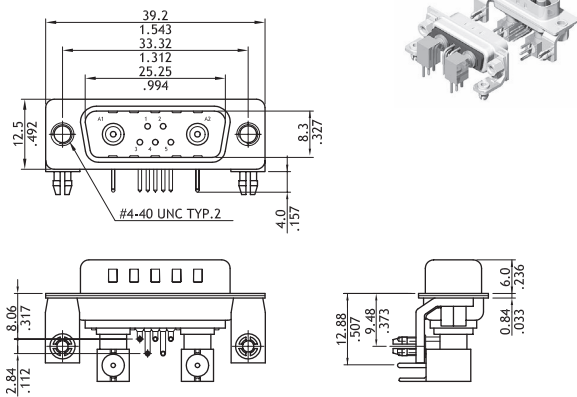

C7W2 (Receptacle Connector)

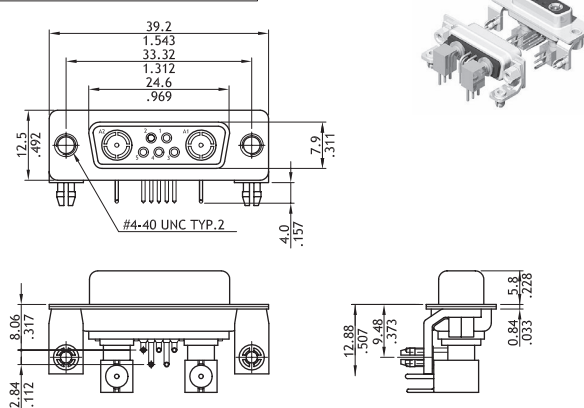

CD

D-SUB CONNECTORS

**Coaxial Right Angle DIP Combination D-Sub**

11W1 (Plug Connector)

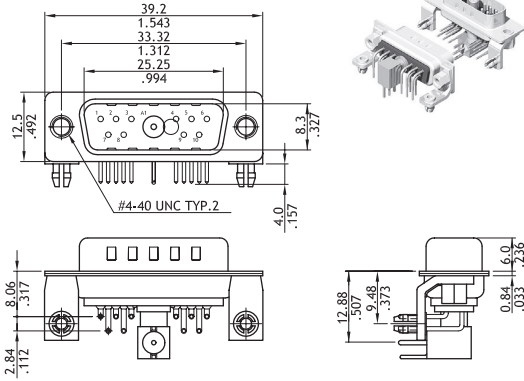

11W1 (Receptacle Connector)

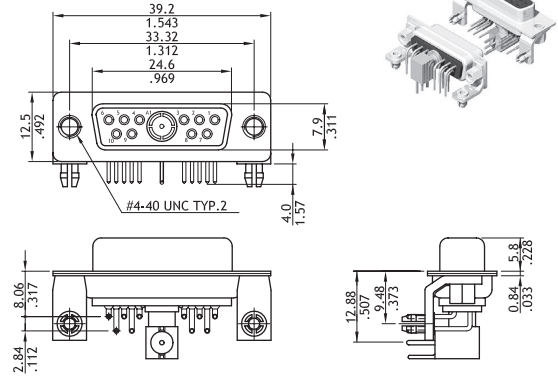

C5W5 (Plug Connector)

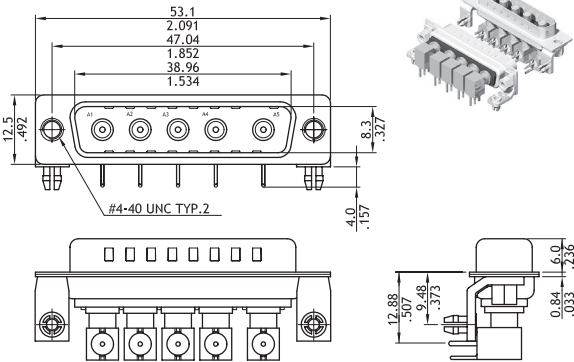

C5W5 (Receptacle Connector)

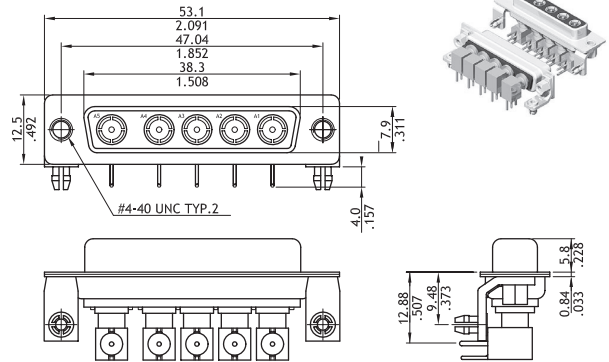

13W3 (Plug Connector)

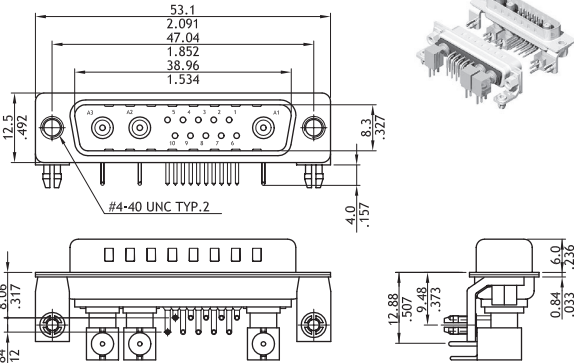

13W3 (Receptacle Connector)

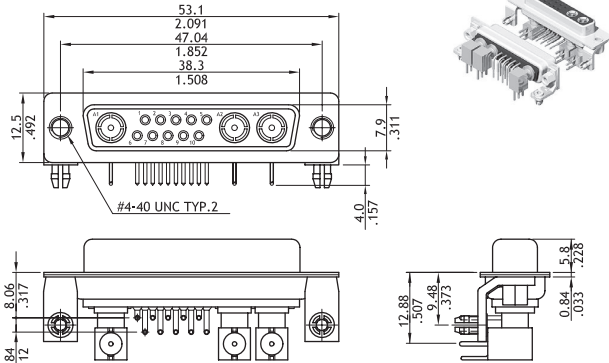

17W2 (Plug Connector)

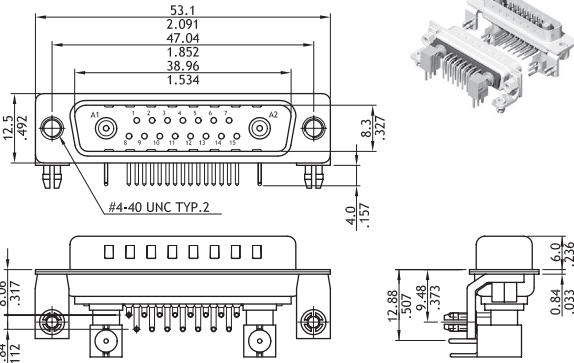

17W2 (Receptacle Connector)

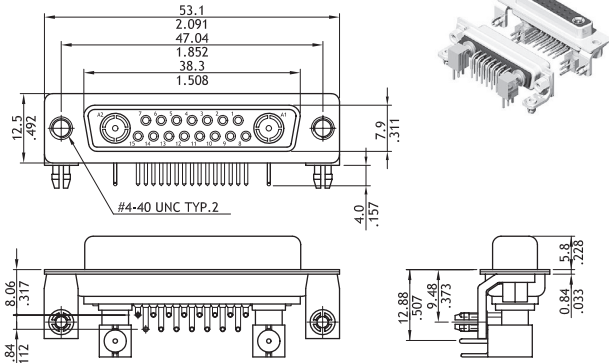

CD

D-SUB CONNECTORS

Coaxial Right Angle DIP Combination D-Sub

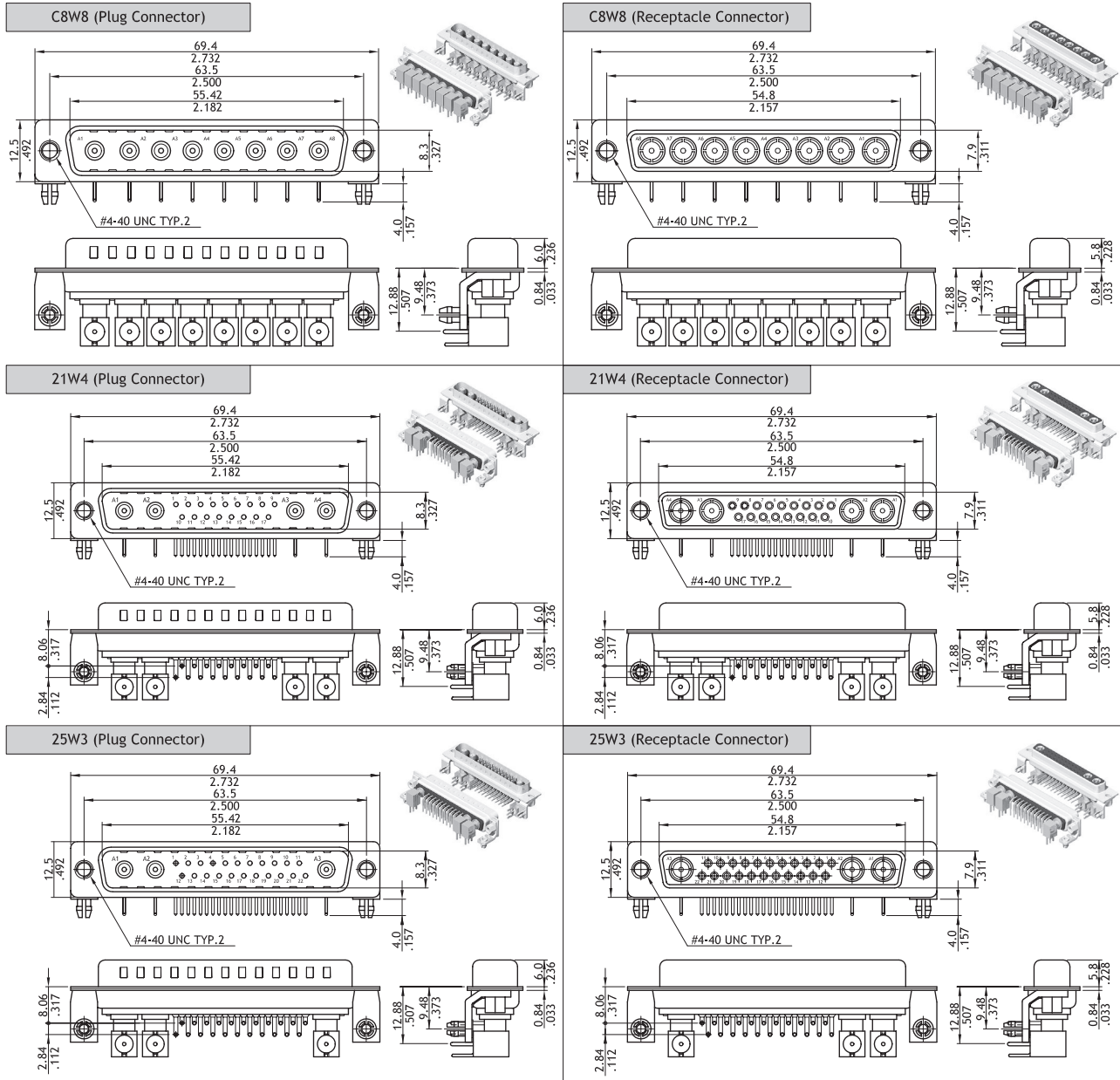

Ordering Code

① ② ③ ④ ⑤ ⑥ ⑦ ⑧ ⑨  
**13W3 S C H 2 2 1 75 I10**

- ① Series No.: C3W3, 3W3C, C7W2, 11W1, C5W5, 13W3, 17W3, C8W8, 21W4, 25W3, 36W4
- ② Connector Type: P = Plug  
S = Receptacle
- ③ Contact Type: C = Coaxial Contact
- ④ Contact Tail Style: H = Right Angle DIP Type
- ⑤ Coaxial Contact Plating: 2 = Gold flash over Nickel
- ⑥ Signal Contact Plating:  
2 = Gold flash over Nickel  
0 = Without Signal Contact

- ⑦ Insulator Color: 1 = Black
  - ⑧ Performance: 50 = 50Ω, 75 = 75Ω
  - ⑨ Mounting Style:  
000 = With  $\phi$  3.05mm holes on shell  
B00 = Riveted #4-40 UNC Close nuts on Front shell  
C00 = Riveted #4-40 UNC Open nuts on Rear shell  
I00 = Riveted #4-40 UNC Ground tabs with  $\phi$  3.2mm holes  
I10 = Riveted #4-40 UNC Ground tabs with board locks (Standard)
- \*Special options consult manufacturer

CD

D-SUB CONNECTORS

**20A High Power Straight DIP Solder Combination D-Sub**

- ⊙ Standard type with #4-40 UNC threaded ground stand-off
- ⊙ Combined with stamped signal and machined 20A high power contacts
- ⊙ For top entry connection
- ⊙ Metal shell with ground indents
- ⊙ Riveted Hex nuts or hardware accessories options available

**RoHS** Compliant 

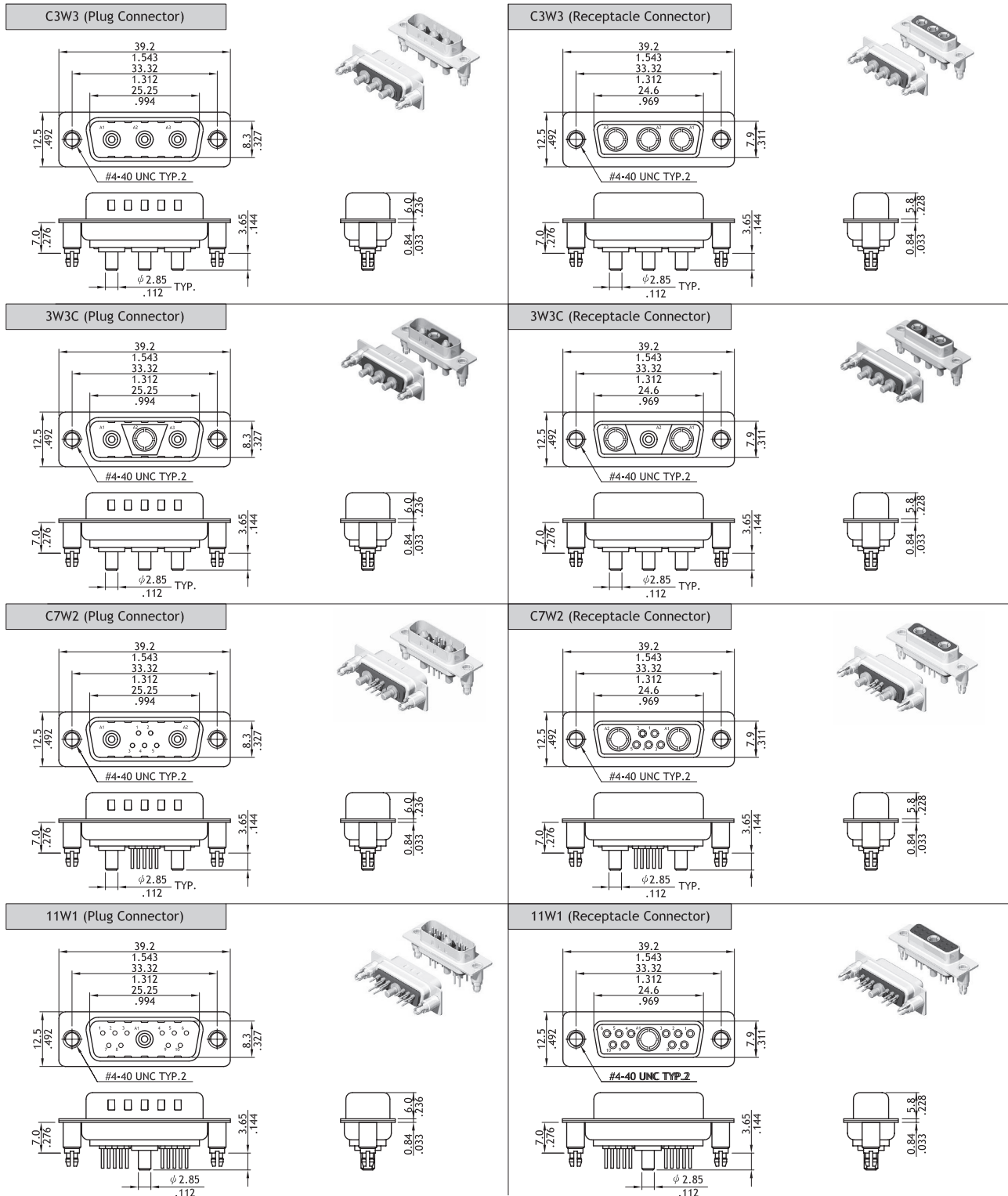

CD

D-SUB CONNECTORS

**20A High Power Straight DIP Solder Combination D-Sub**

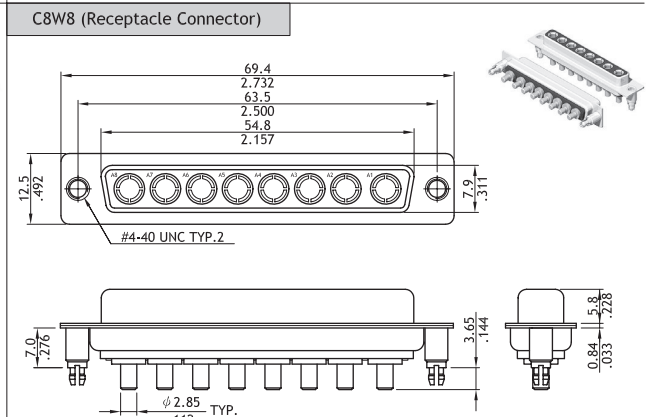
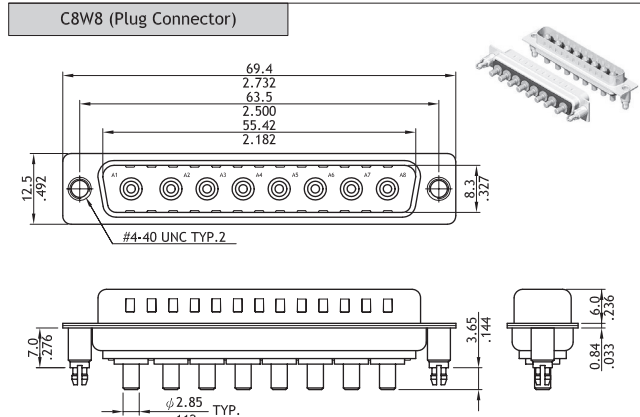
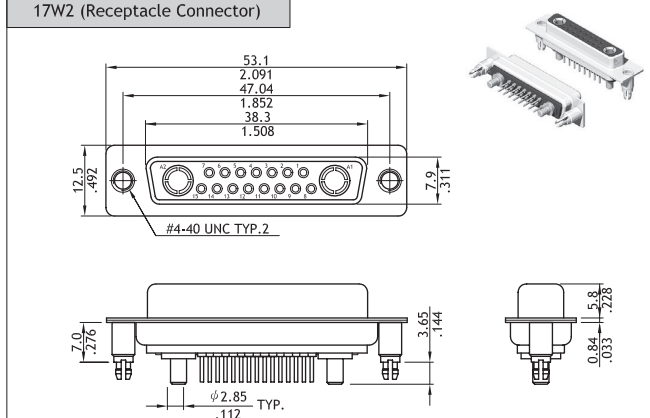
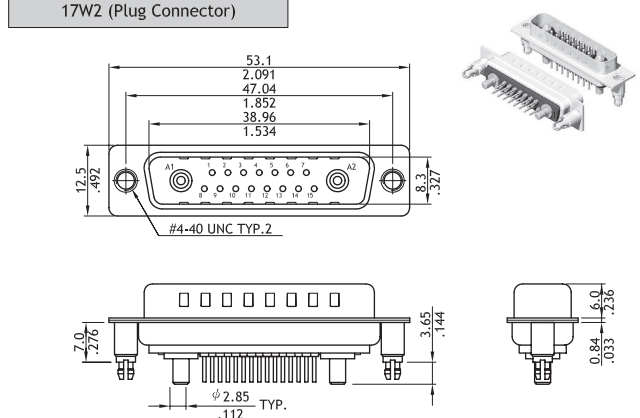
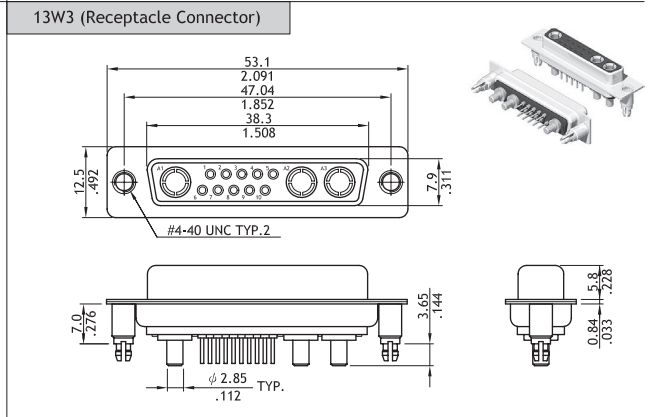
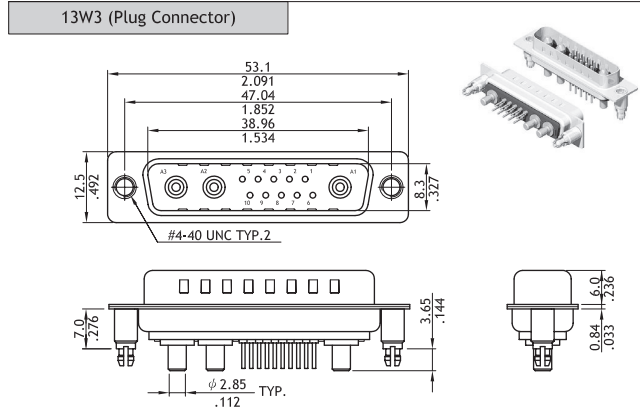
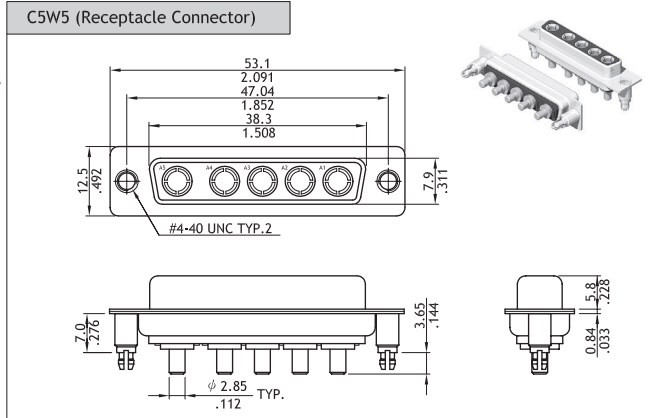
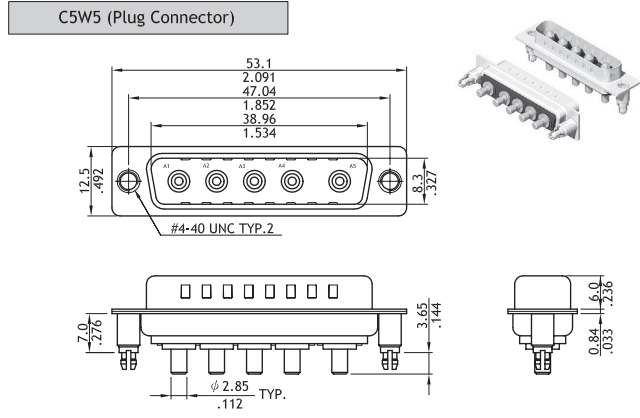

CD

D-SUB CONNECTORS

20A High Power Straight DIP Solder Combination D-Sub

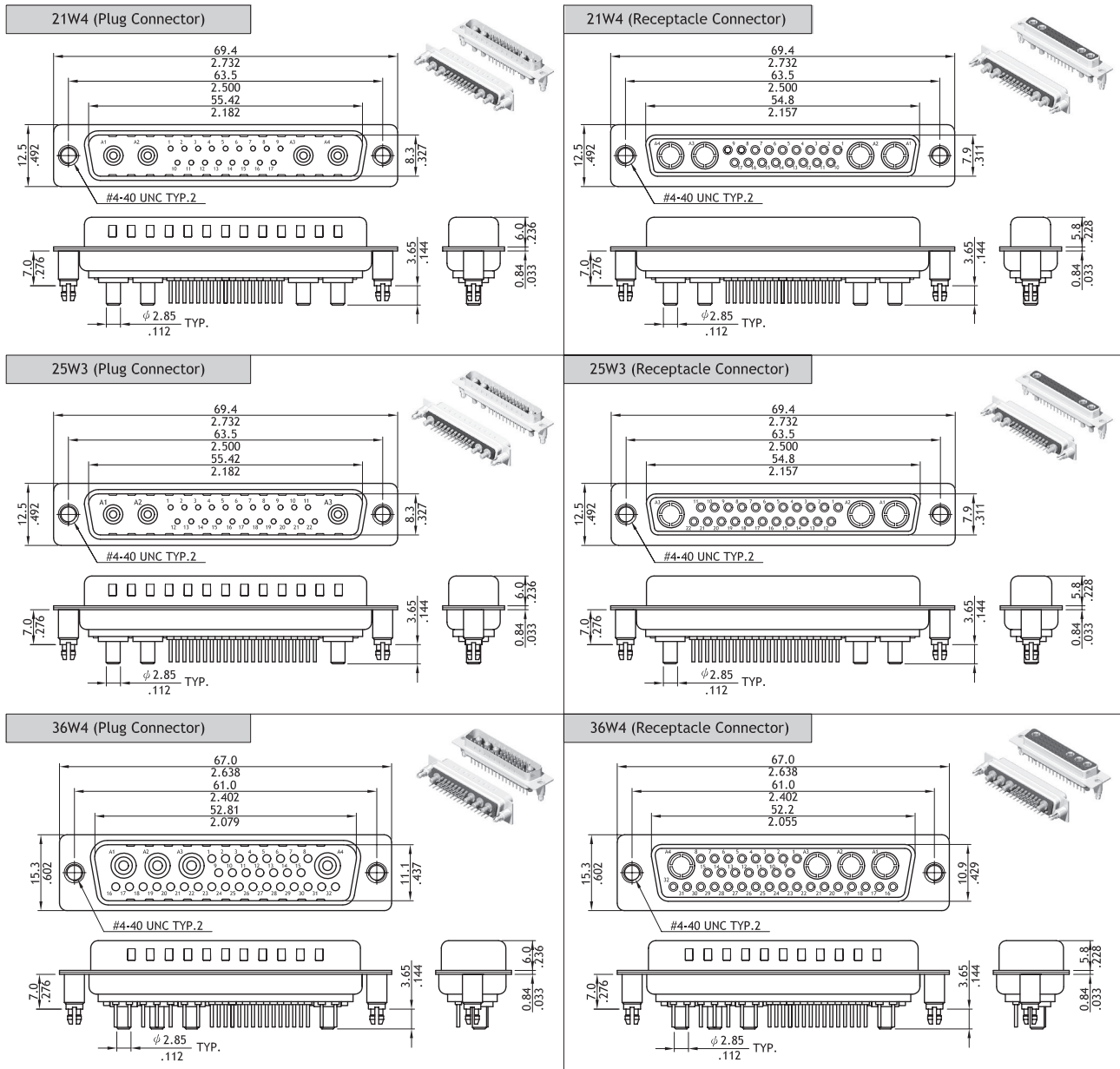

CD

Ordering Code

① ② ③ ④ ⑤ ⑥ ⑦ ⑧ ⑨  
**13W3 S P V 2 2 1 20 D00**

- ① Series No.: C3W3, 3W3C, C7W2, 11W1, C5W5, 13W3, 17W3, C8W8, 21W4, 25W3, 36W4
- ② Connector Type: P = Plug  
S = Receptacle
- ③ Contact Type: P = High power Contact
- ④ Contact Tail Style: V = Straight DIP Type
- ⑤ Coaxial Contact Plating: 2 = Gold flash over Nickel
- ⑥ Signal Contact Plating: 2 = Gold flash over Nickel  
0 = Without Signal Contact

- ⑦ Insulator Color: 1 = Black
- ⑧ Performance: 20 = 20A
- ⑨ Mounting Style:  
000 = With  $\phi$  3.05mm holes on shell  
A00 = Riveted #4-40 UNC Close nuts on Front shell  
B00 = Riveted #4-40 UNC Open nuts on Front shell  
C00 = Riveted #4-40 UNC Open nuts on Rear shell  
D00 = Riveted #4-40 UNC Ground Stand-off (Standard)  
\*Special options consult manufacturer

## 40A High Power Straight DIP Solder Combination D-Sub

- ⊙ Standard type with #4-40 UNC threaded ground stand-off
- ⊙ Combined with stamped signal and machined 40A high power contacts
- ⊙ For top entry connection
- ⊙ Metal shell with ground indents
- ⊙ Riveted Hex nuts or hardware accessories options available

RoHS Compliant

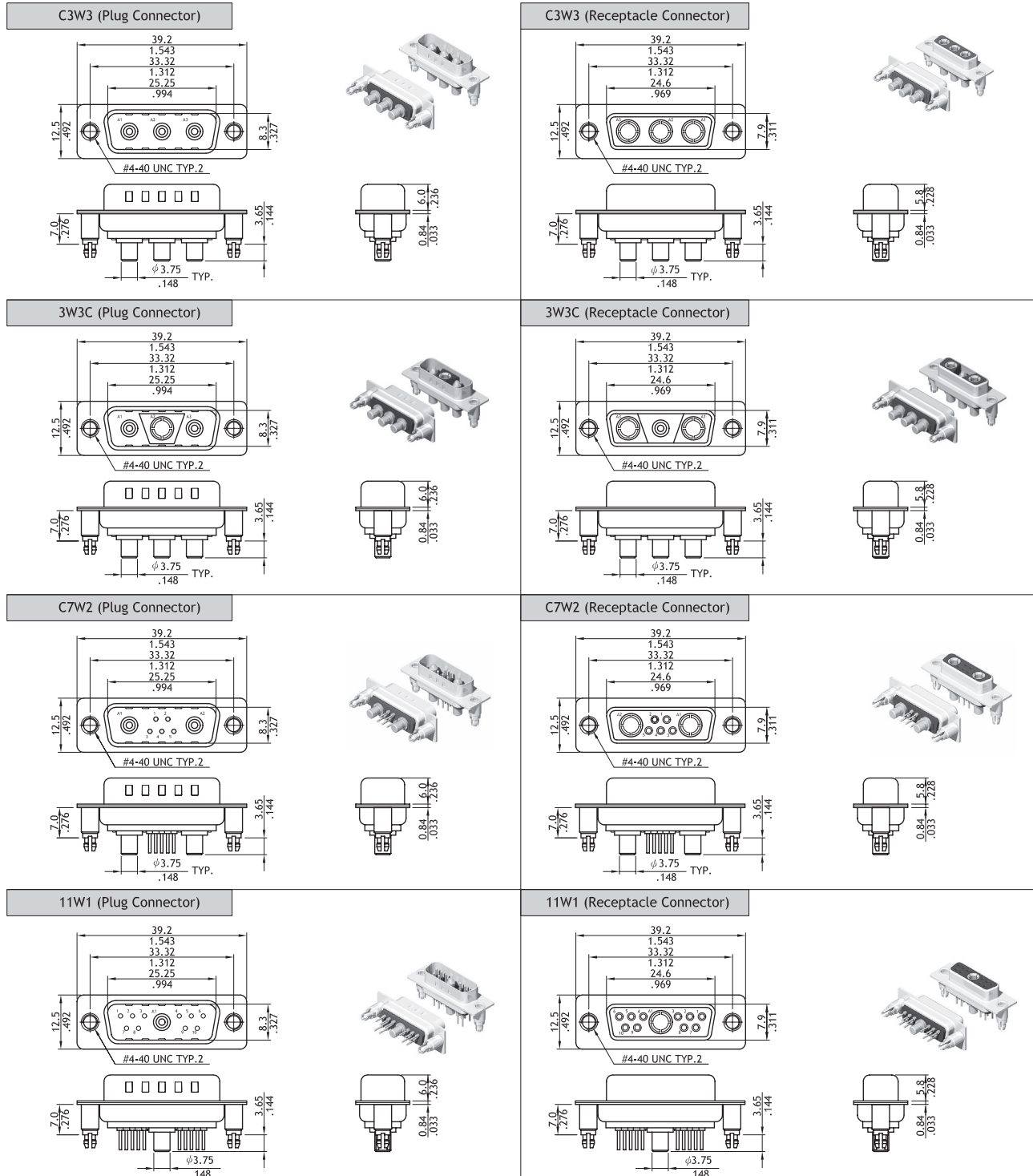

40A High Power Straight DIP Solder Combination D-Sub

C5W5 (Plug Connector)

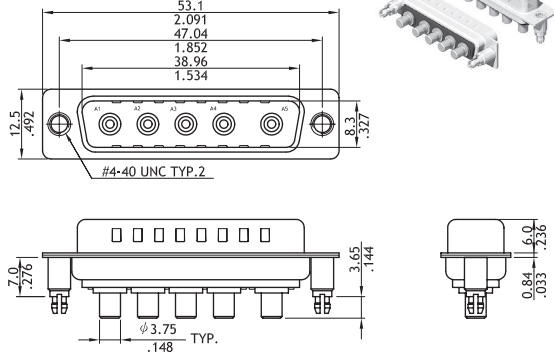

C5W5 (Receptacle Connector)

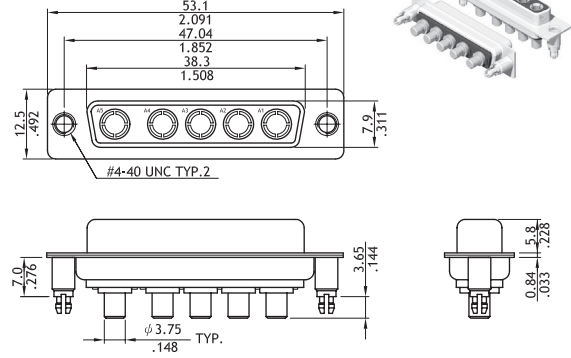

13W3 (Plug Connector)

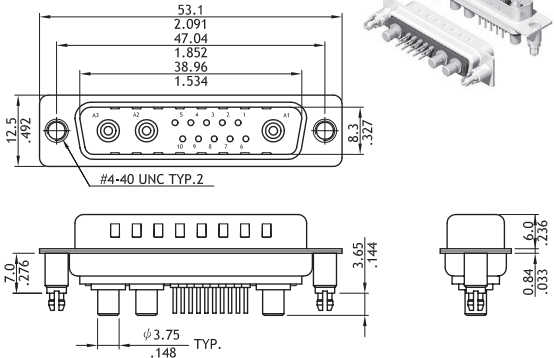

13W3 (Receptacle Connector)

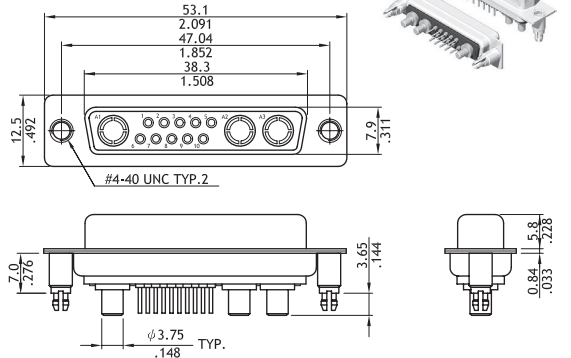

17W2 (Plug Connector)

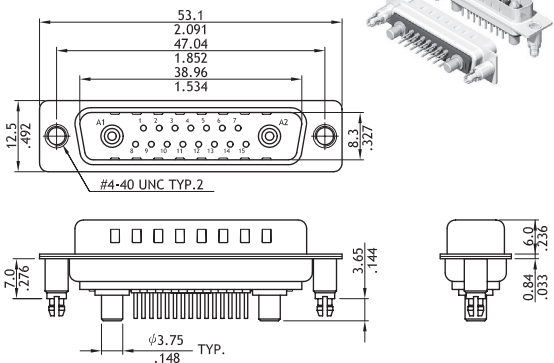

17W2 (Receptacle Connector)

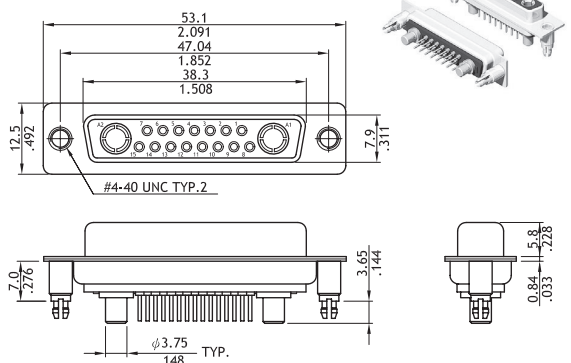

C8W8 (Plug Connector)

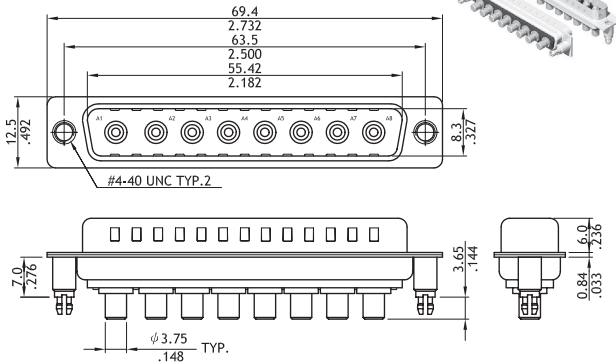

C8W8 (Receptacle Connector)

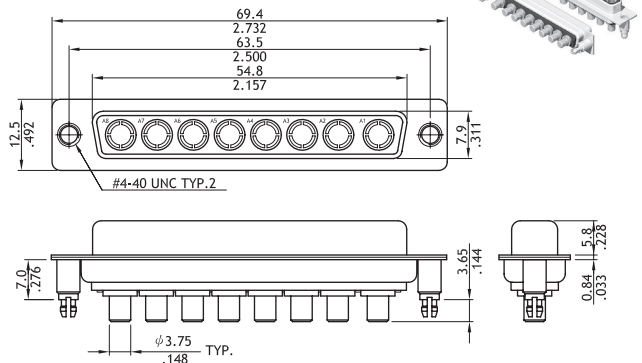

CD

D-SUB CONNECTORS

40A High Power Straight DIP Solder Combination D-Sub

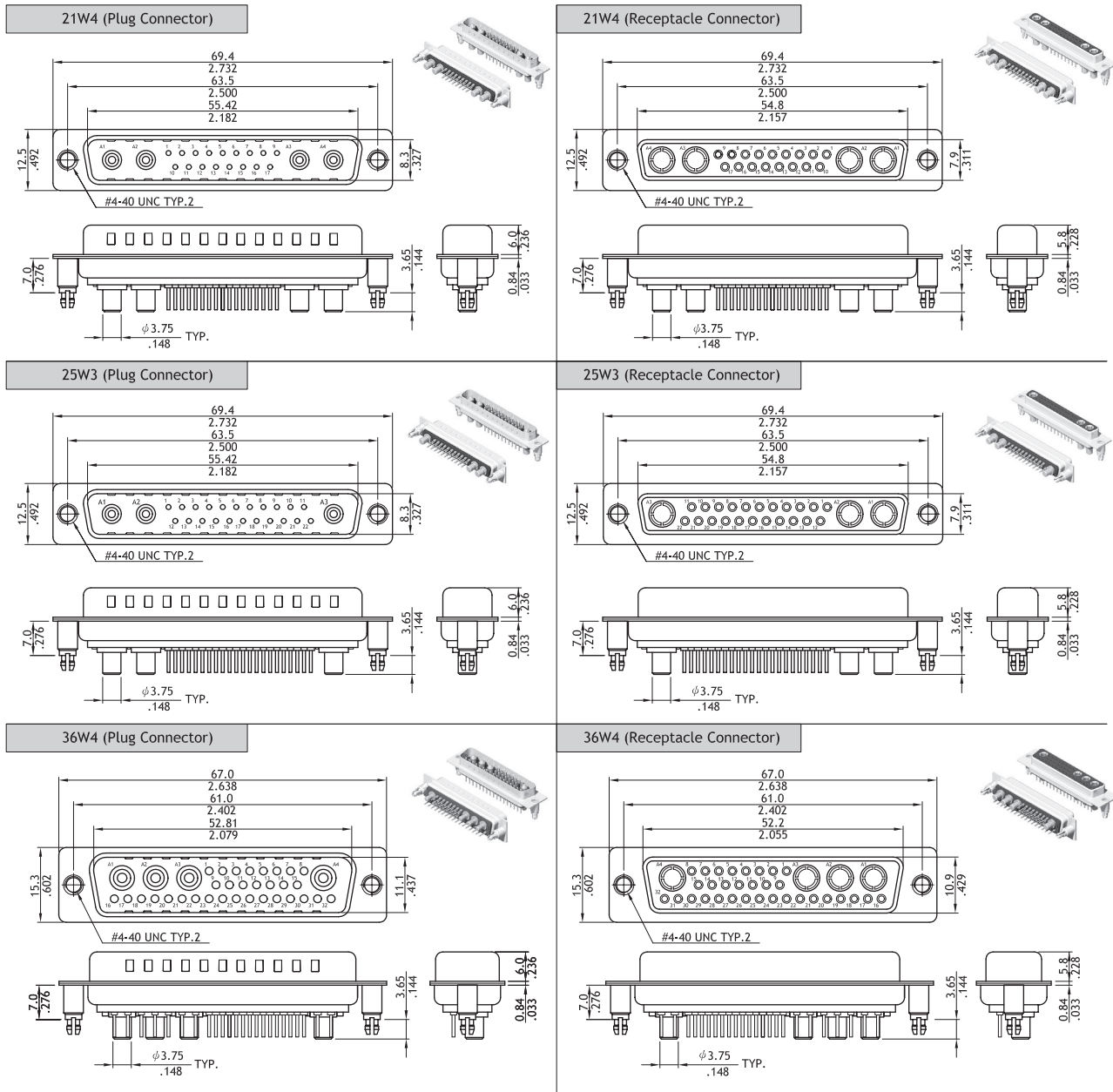

Ordering Code

① ② ③ ④ ⑤ ⑥ ⑦ ⑧ ⑨  
**13W3 S P V 2 2 1 40 D00**

- ① Series No.: C3W3, 3W3C, C7W2, 11W1, C5W5, 13W3, 17W3, C8W8, 21W4, 25W3, 36W4
- ② Connector Type: P = Plug  
S = Receptacle
- ③ Contact Type: P = High power Contact
- ④ Contact Tail Style: V = Straight DIP Type
- ⑤ Coaxial Contact Plating: 2 = Gold flash over Nickel
- ⑥ Signal Contact Plating: 2 = Gold flash over Nickel  
0 = Without Signal Contact

- ⑦ Insulator Color: 1 = Black
- ⑧ Performance: 40 = 40A
- ⑨ Mounting Style:  
000 = With  $\phi$  3.05mm holes on shell  
A00 = Riveted #4-40 UNC Close nuts on Front shell  
B00 = Riveted #4-40 UNC Open nuts on Front shell  
C00 = Riveted #4-40 UNC Open nuts on Rear shell  
D00 = Riveted #4-40 UNC Ground Stand-off (Standard)  
\*Special options consult manufacturer

CD

D-SUB CONNECTORS

**20A High Power Right Angle DIP Combination D-Sub**

- ⊙ Standard type with #4-40 UNC threaded ground tabs and board locks to secure connector on board
- ⊙ Combined with stamped signal and machined 20A high power contacts
- ⊙ For side entry connection
- ⊙ Metal shell with ground indents
- ⊙ Riveted Hex nuts or hardware accessories options available

RoHS Compliant 

C3W3 (Plug Connector)

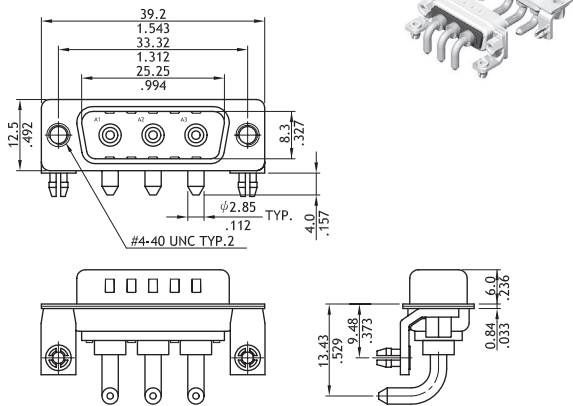

C3W3 (Receptacle Connector)

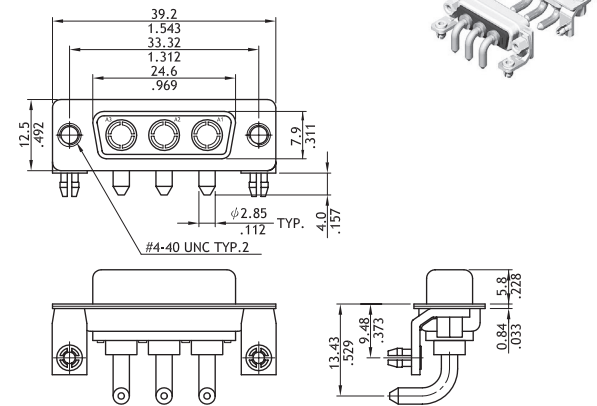

3W3C (Plug Connector)

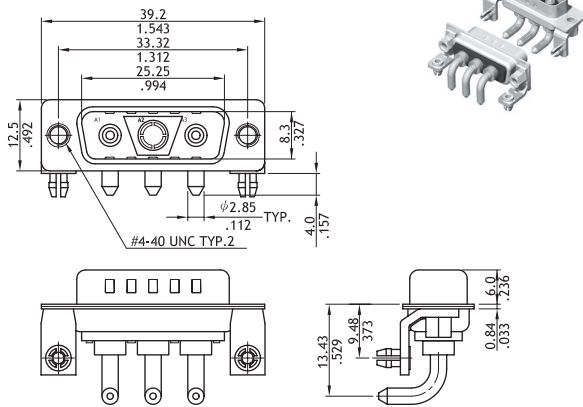

3W3C (Receptacle Connector)

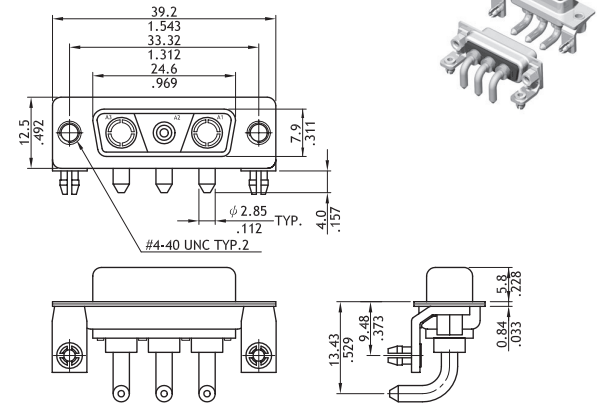

C7W2 (Plug Connector)

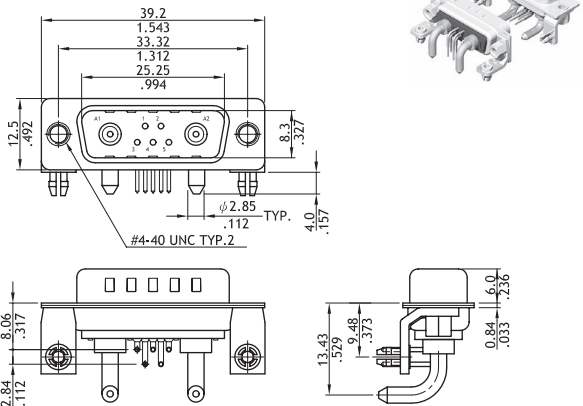

C7W2 (Receptacle Connector)

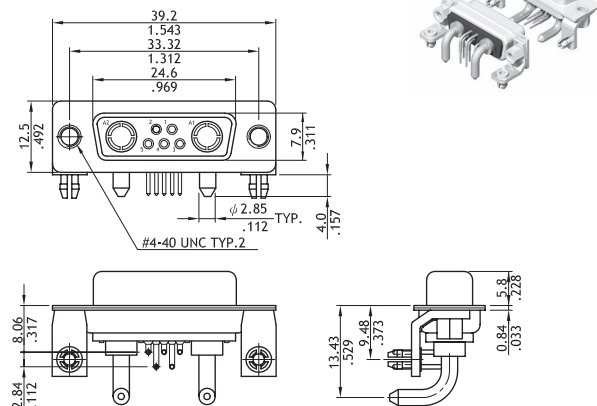

CD

D-SUB CONNECTORS

**20A High Power Right Angle DIP Combination D-Sub**

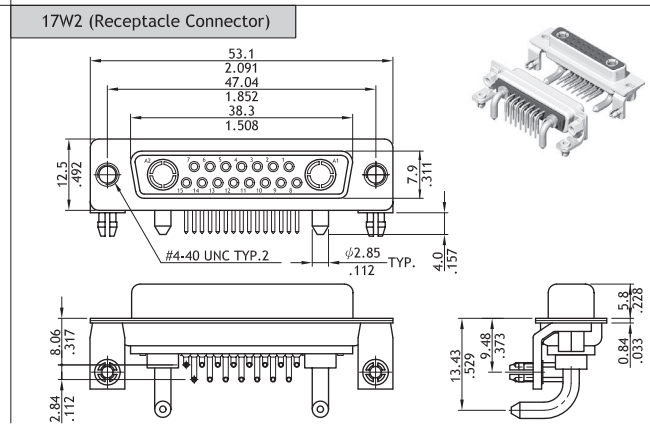
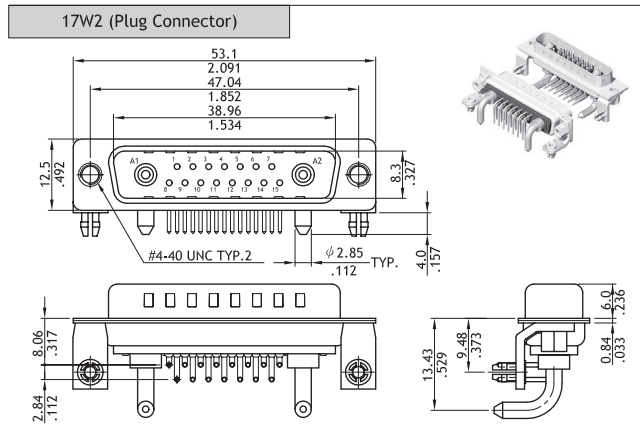
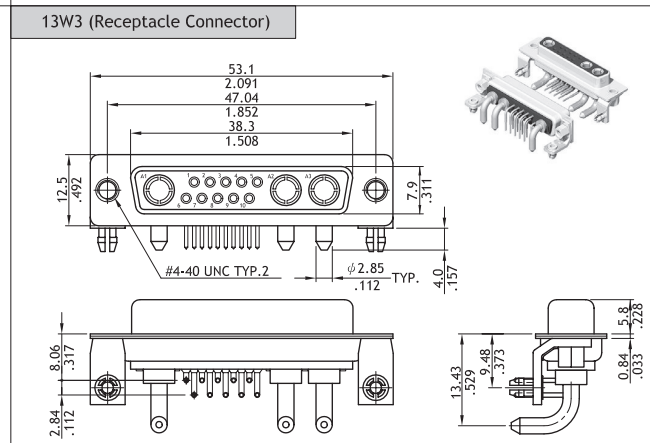
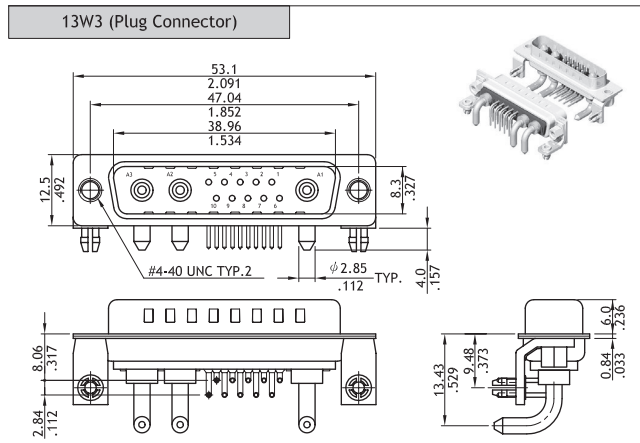
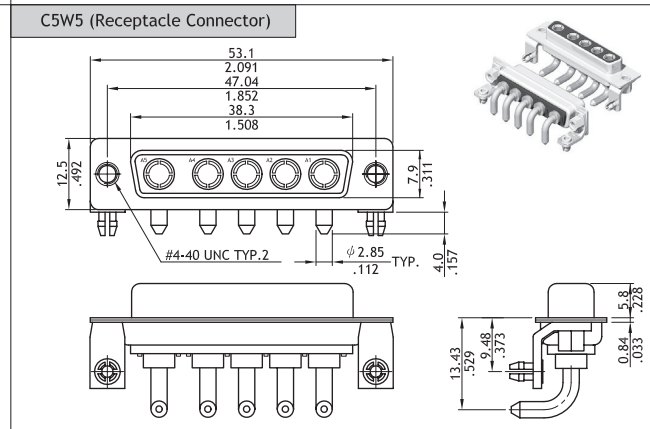
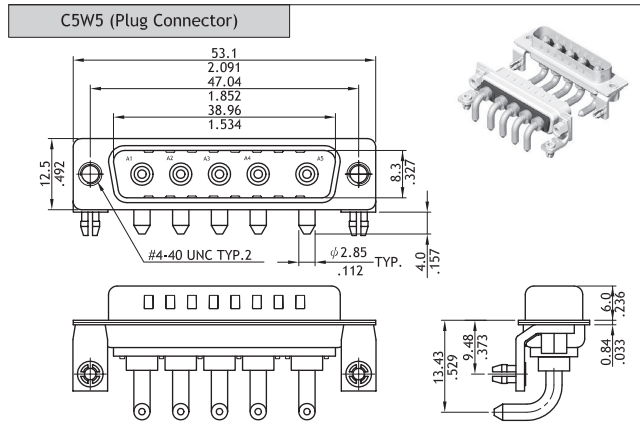
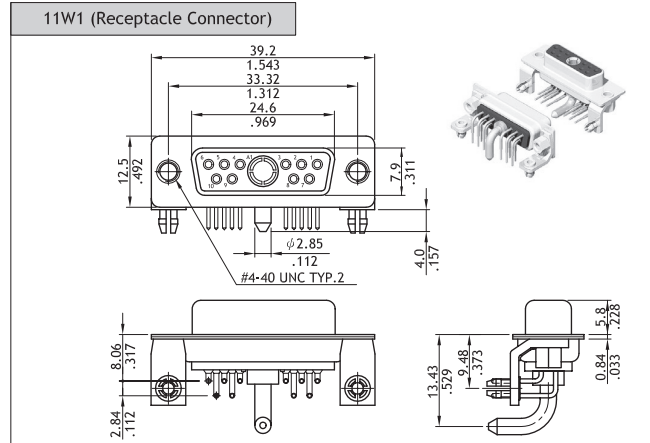
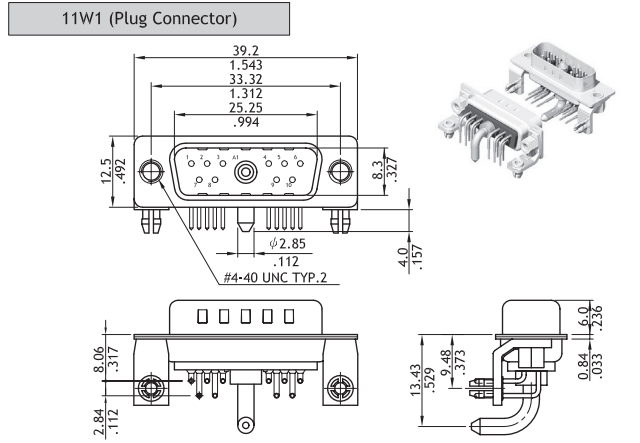

CD

D-SUB CONNECTORS

20A High Power Right Angle DIP Combination D-Sub

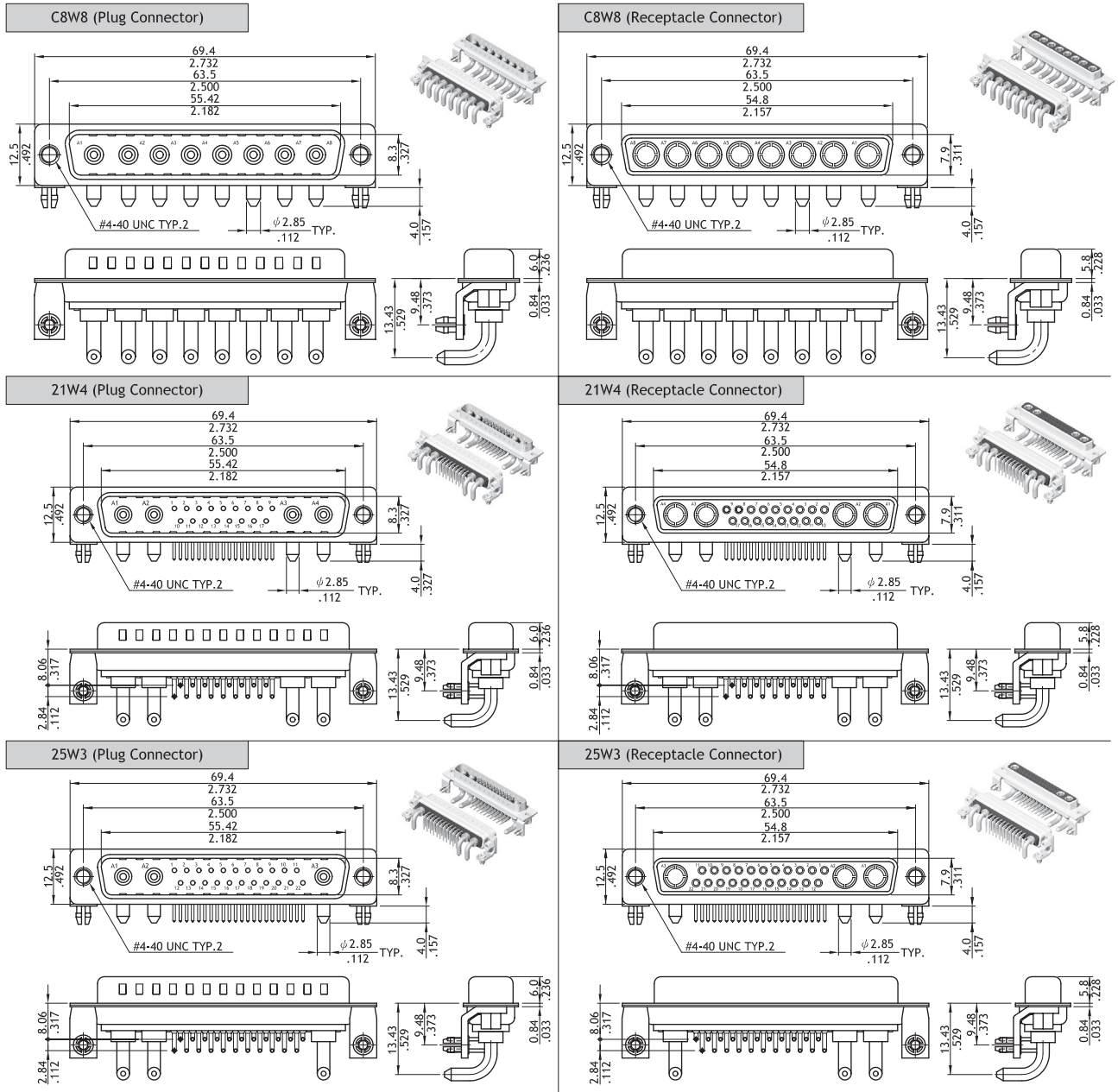

Ordering Code

① 13W3 ② S ③ P ④ H ⑤ 2 ⑥ 2 ⑦ 1 ⑧ 2 ⑨ 100

- ① Series No.: C3W3, 3W3C, C7W2, 11W1, C5W5, 13W3, 17W3, C8W8, 21W4, 25W3, 36W4
- ② Connector Type: P = Plug  
S = Receptacle
- ③ Contact Type: P = High power Contact
- ④ Contact Tail Style: H = Right Angle DIP Type
- ⑤ High Power Contact Plating: 2 = Gold flash over Nickel
- ⑥ Signal Contact Plating: 2 = Gold flash over Nickel  
0 = Without Signal Contact

- ⑦ Insulator Color: 1 = Black
- ⑧ Performance: 20 = 20A
- ⑨ Mounting Style:  
000 = With  $\phi$  3.05mm holes on shell  
B00 = Riveted #4-40 UNC Open nuts on Front shell  
C00 = Riveted #4-40 UNC Open nuts on Rear shell  
100 = Riveted #4-40 UNC Ground tabs with  $\phi$  3.2mm holes  
110 = Riveted #4-40 UNC Ground tabs with borad locks  
\*Special options consult manufacturer

CD

D-SUB CONNECTORS

### 40A High Power Right Angle DIP Combination D-Sub

- ⊙ Standard type with #4-40 UNC threaded ground tabs and board locks to secure connector on board
- ⊙ Combined with stamped signal and 40A high power contacts
- ⊙ For side entry connection
- ⊙ Metal shell with ground indents
- ⊙ Riveted Hex nuts or hardware accessories options available

RoHS Compliant

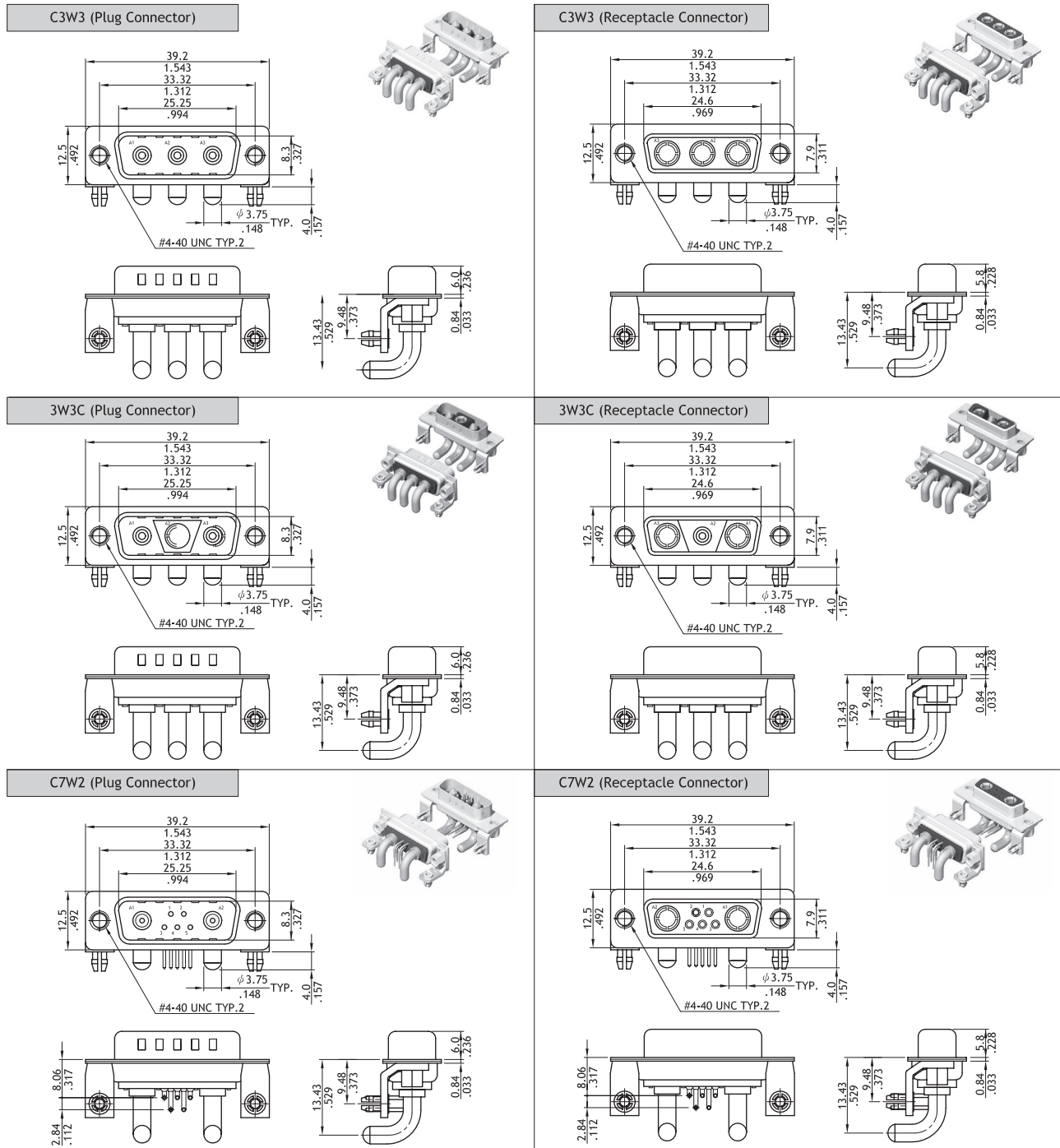

CD

D-SUB CONNECTORS

40A High Power Right Angle DIP Combination D-Sub

11W1 (Plug Connector)

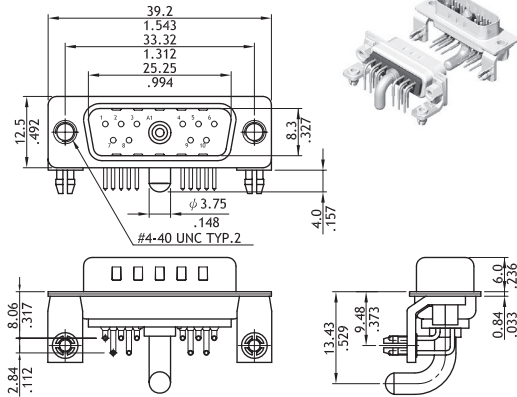

11W1 (Receptacle Connector)

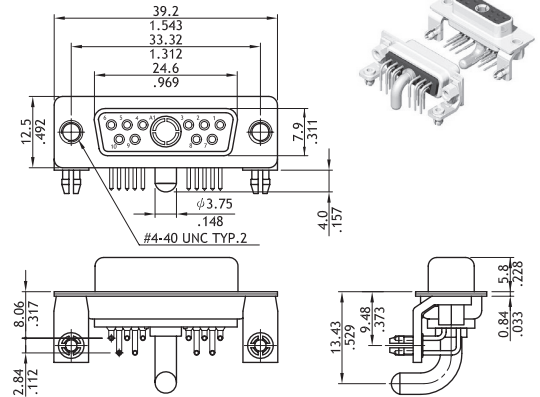

C5W5 (Plug Connector)

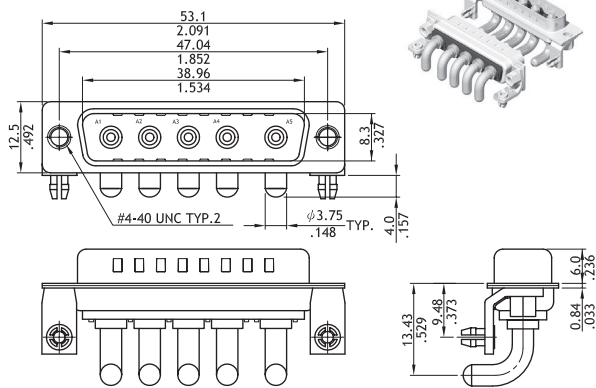

C5W5 (Receptacle Connector)

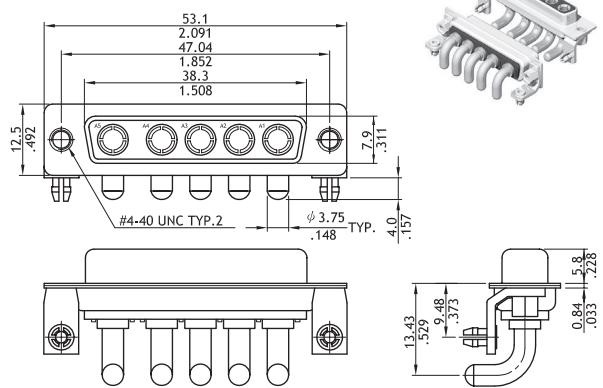

13W3 (Plug Connector)

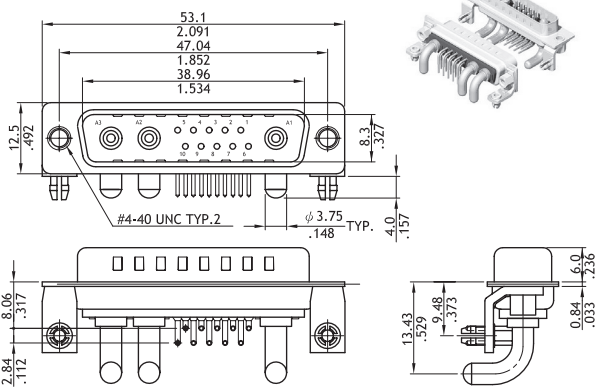

13W3 (Receptacle Connector)

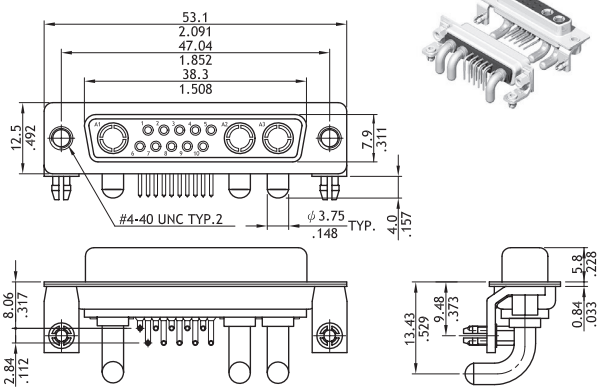

17W2 (Plug Connector)

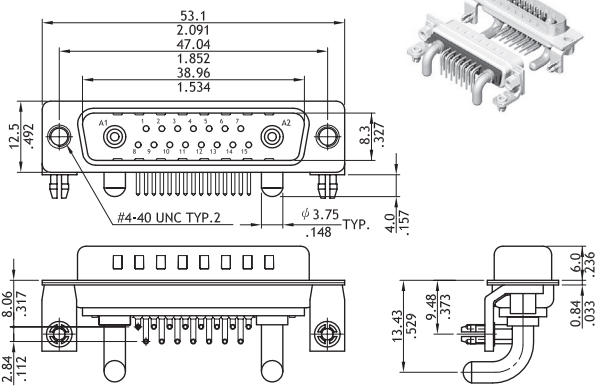

17W2 (Receptacle Connector)

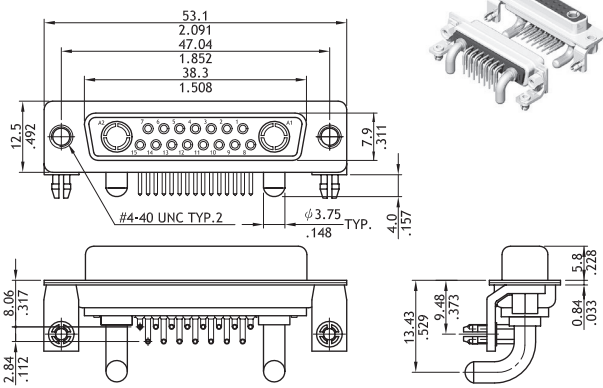

# 40A High Power Right Angle DIP Combination D-Sub

C8W8 (Plug Connector)

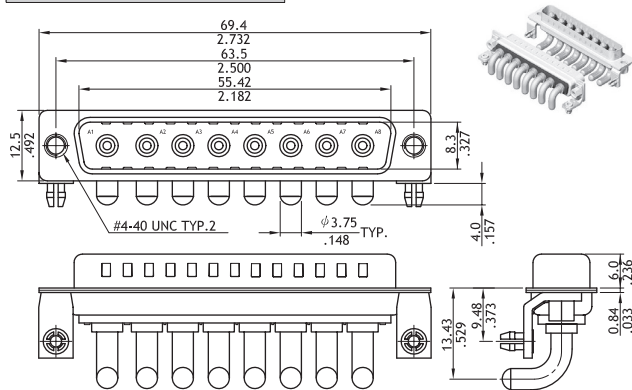

C8W8 (Receptacle Connector)

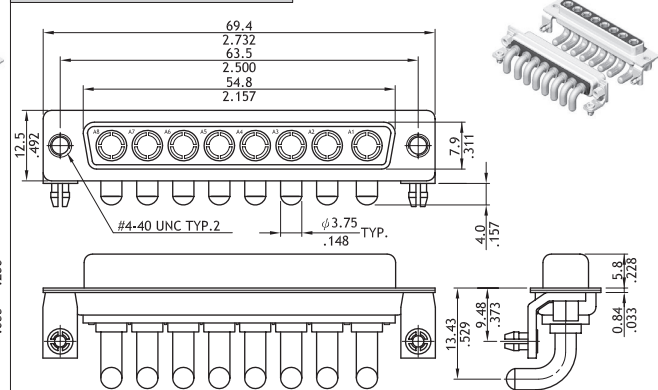

21W4 (Plug Connector)

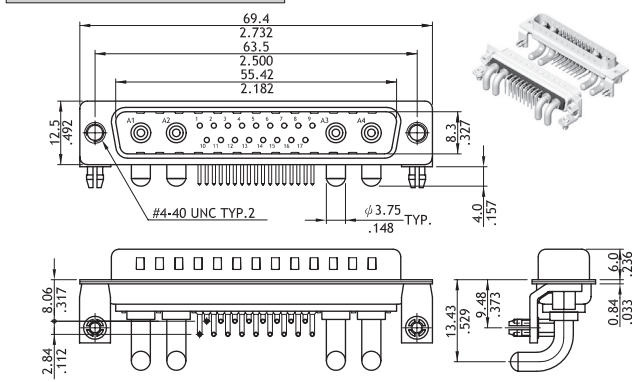

21W4 (Receptacle Connector)

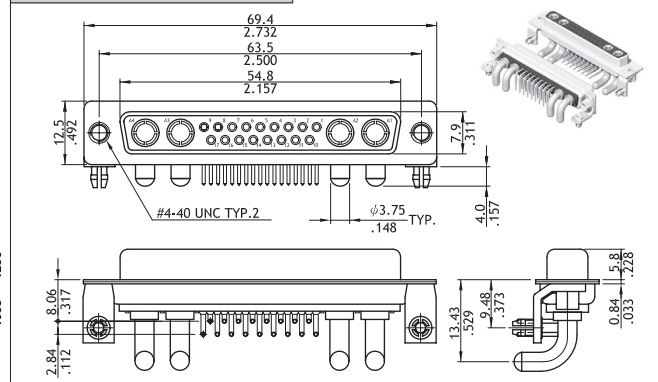

25W3 (Plug Connector)

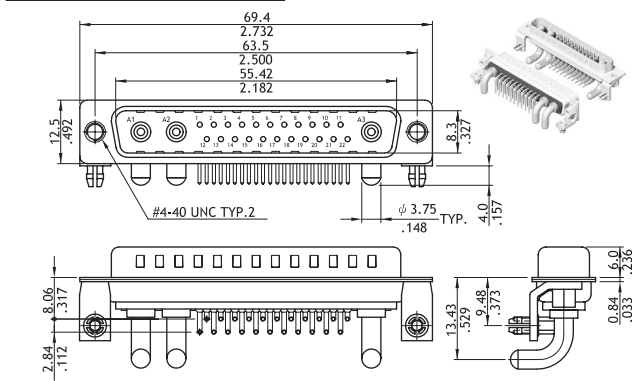

25W3 (Receptacle Connector)

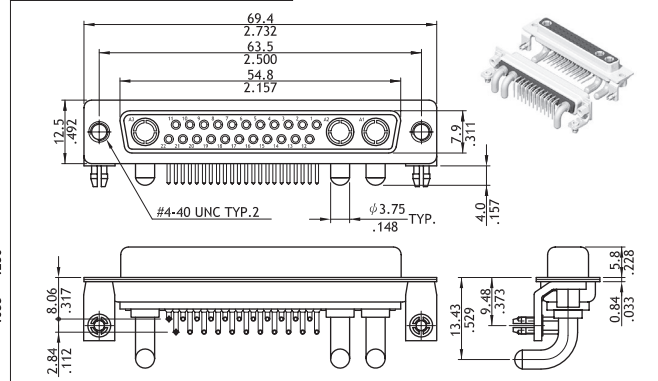

Ordering Code	①	②	③	④	⑤	⑥	⑦	⑧	⑨
	13W3	S	P	H	2	2	1	40	100
① Series No.:	C3W3, 3W3C, C7W2, 11W1, C5W5, 13W3, 17W3, C8W8, 21W4, 25W3, 36W4			⑦ Insulator Color:	1 = Black				
② Connector Type:	P = Plug S = Receptacle			⑧ Performance:	40 = 40A				
③ Contact Type:	P = High power Contact			⑨ Mounting Style:	000 = With $\phi$ 3.05mm holes on shell B00 = Riveted #4-40 UNC Open nuts on Front shell C00 = Riveted #4-40 UNC Open nuts on Rear shell I00 = Riveted #4-40 UNC Ground tabs with $\phi$ 3.2mm holes I10 = Riveted #4-40 UNC Ground tabs with borad locks (Standard)				
④ Contact Tail Style:	H = Right Angle DIP Type			*Special options consult manufacturer					
⑤ High Power Contact Plating:	2 = Gold flash over Nickel								
⑥ Signal Contact Plating:	2 = Gold flash over Nickel 0 = Without Signal Contact								

CD

D-SUB CONNECTORS

**CJ04 Series Board Mount Telephone Jacks**

- ⊙ Available in 4 and 6 ways
- ⊙ Insulator: Gray, Glass Filled polyester
- ⊙ Flammability Rating: UL 94V-0
- ⊙ Cavity confirms to FCC rules and regulations PART 68, SUBPART F

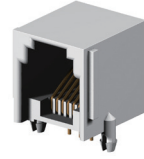

**RoHS** Compliant

P/N CJ044\*\*1900

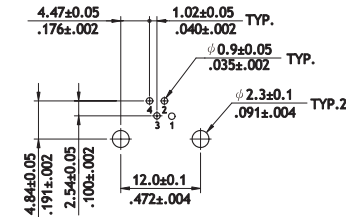
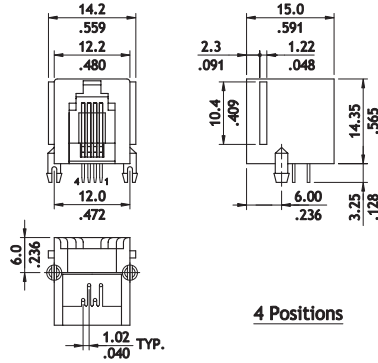

P/N CJ046\*\*1900

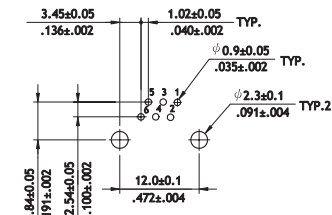
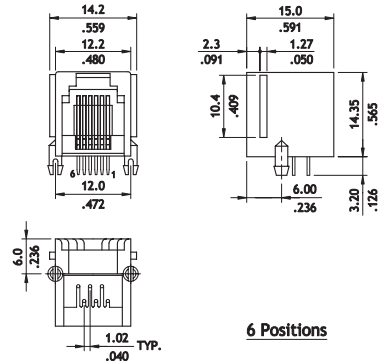

**CJ07 Series Board Mount Telephone Jacks**

- ⊙ Available in 4, 6 and 8 ways
- ⊙ Insulator: Black, Glass Filled polyester
- ⊙ Cavity confirms to FCC rules and regulations PART 68, SUBPART F

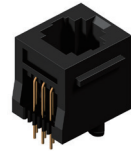

**RoHS** Compliant

P/N CJ074\*\*1100

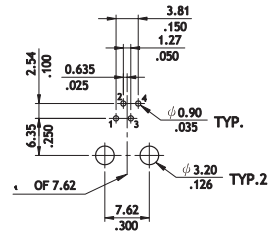
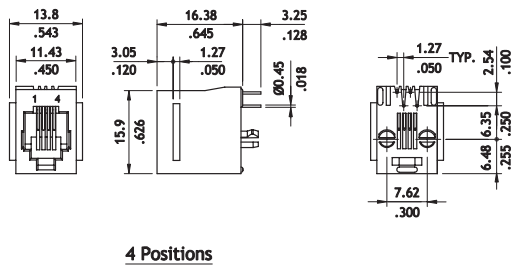

P/N CJ076\*\*1100

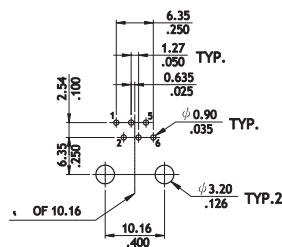
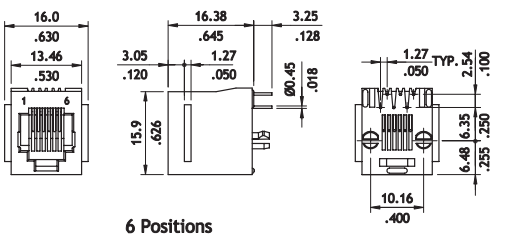



**CJ31 Series Board Mount Telephone Jacks**

- ⊙ Available in 6, 8 and 10 ways
- ⊙ Insulator: Black, Glass Filled polyester
- ⊙ Flammability Rating: UL 94V-0
- ⊙ Cavity confirms to FCC rules and regulations
- ⊙ PART 68, SUBPART F



**RoHS** Compliant

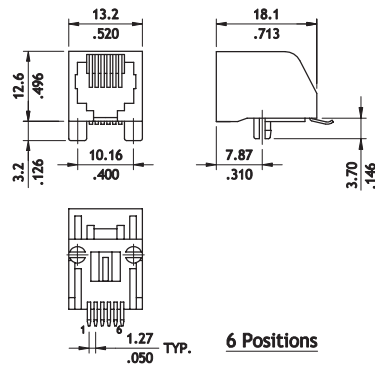

**P/N CJ316\*\*11SM**

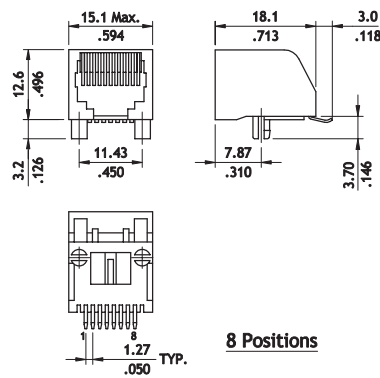
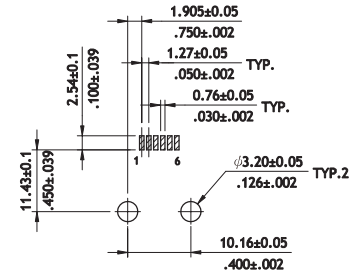

**P/N CJ318\*\*11SM**

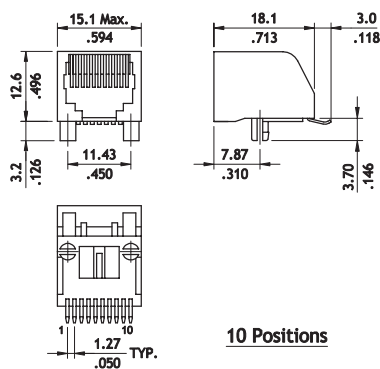
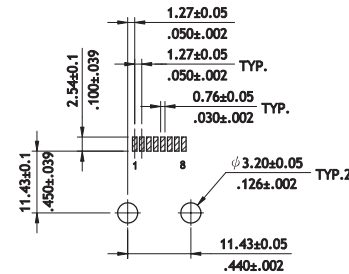

**P/N CJ31AA\*11SM**

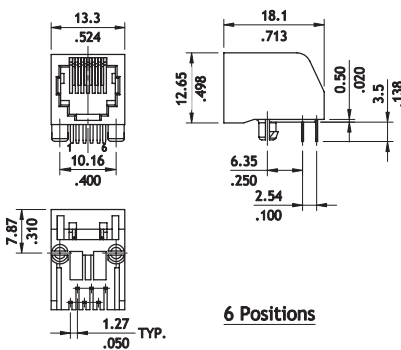
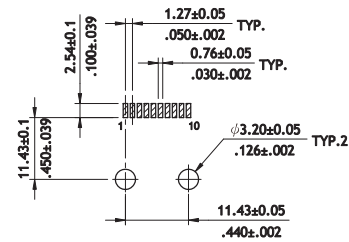

**P/N CJ316\*\*1100**

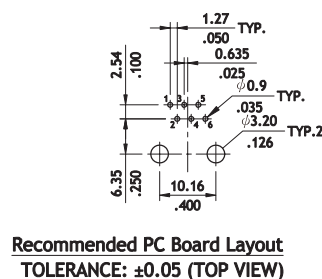

### CJ31 Series Board Mount Telephone Jacks

- ⊙ Available in 6, 8 and 10 ways
- ⊙ Insulator: Black, Glass Filled polyester
- ⊙ Flammability Rating: UL 94V-0
- ⊙ Cavity confirms to FCC rules and regulations
- ⊙ PART 68, SUBPART F



**RoHS** Compliant

**P/N CJ318\*\*1100**

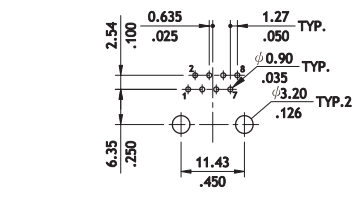
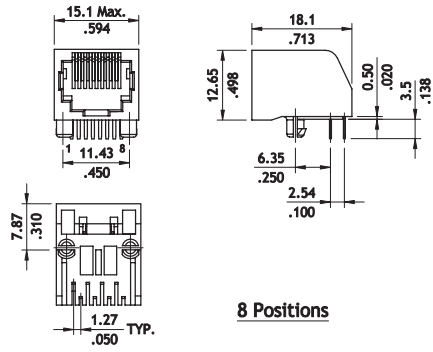

**P/N CJ31AA\*1100**

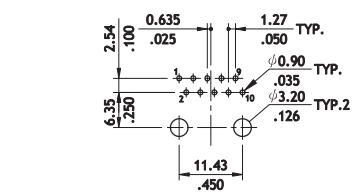
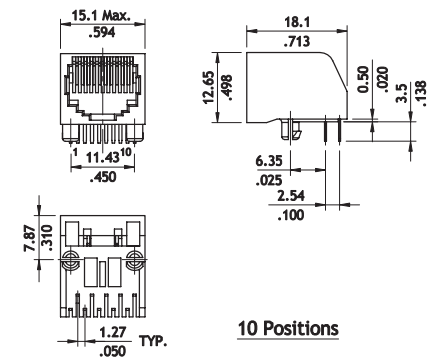

**P/N CJ318\*\*110K**

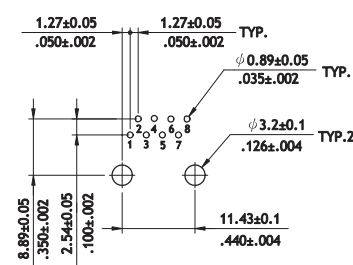
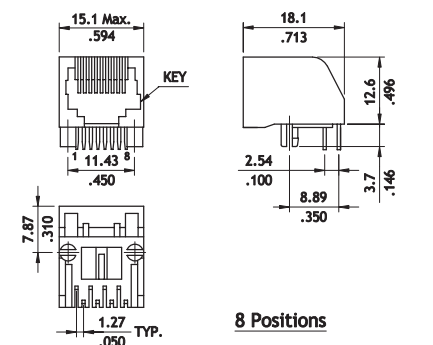

**P/N CJ31AA\*110K**

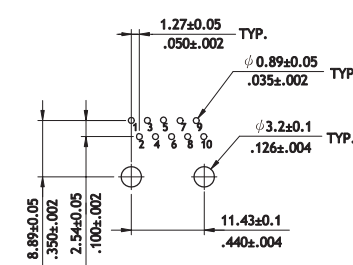
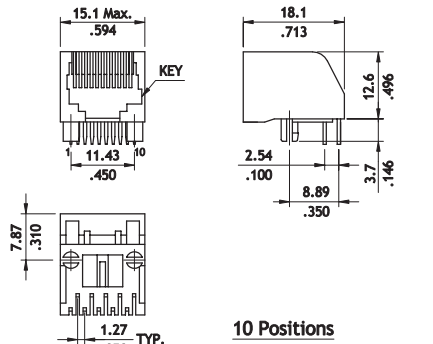

CJ

TELEPHONE/MODULAR JACK

**CJ46 Series Board Mount Telephone Jacks**

- ⊙ Available in 4, 6 and 8 ways
- ⊙ Insulator: Black, Glass Filled polyester
- ⊙ Flammability Rating: UL 94V-0
- ⊙ Cavity confirms to FCC rules and regulations PART 68, SUBPART F

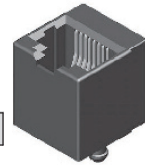

P/N CJ4688\*1100

RoHS Compliant

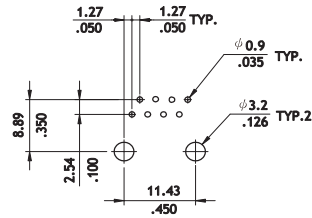
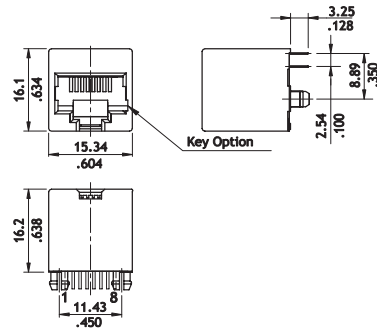

Recommended PC Board Layout  
PCB THICKNESS: 1.6mm  
TOLERANCE: ±0.05mm (TOP VIEW)

8 Positions

**CJ47 Series Board Mount Telephone Jacks**

- ⊙ Available in 8 ways
- ⊙ Flammability Rating: UL 94V-0
- ⊙ Cavity confirms to FCC rules and regulations PART 68, SUBPART F

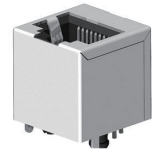

P/N CJ4788\*110\*

RoHS Compliant

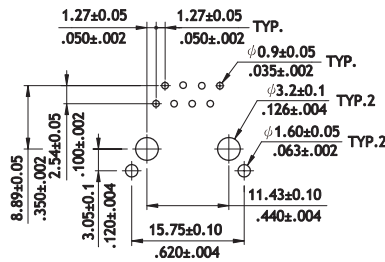
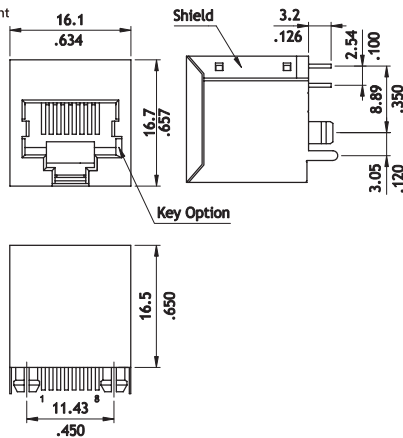

Recommended P.C. Board Layout

**CJ58 Series Board Mount Telephone Jacks**

- ⊙ Available in 8 ways
- ⊙ Flammability Rating: UL 94V-0
- ⊙ Cavity confirms to FCC rules and regulations PART 68, SUBPART F

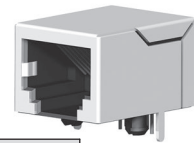

P/N CJ5888\*1100

RoHS Compliant

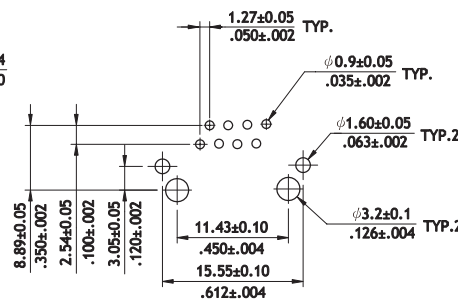
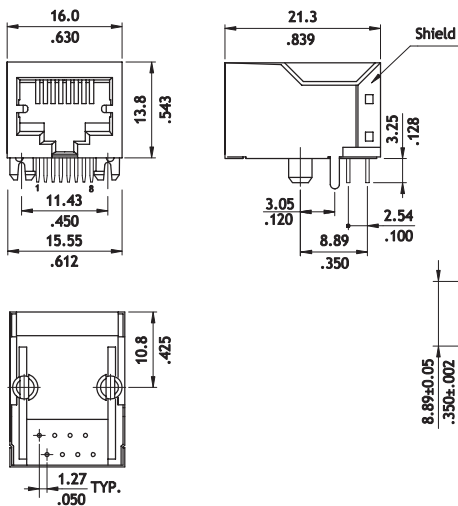

Recommended PC Board Layout

### CJ48 Series Board Mount Telephone Jacks

- ⊙ Available in 1, 2, 4, 6 and 8 ports
- ⊙ With metal shielding
- ⊙ With metal grounding and PCB pegs
- ⊙ Insulator: Black, Glass Filled polyester
- ⊙ Flammability Rating: UL 94V-0
- ⊙ Cavity conforms to FCC rules and regulations PART 68, SUBPART F

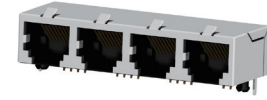

**RoHS** Compliant

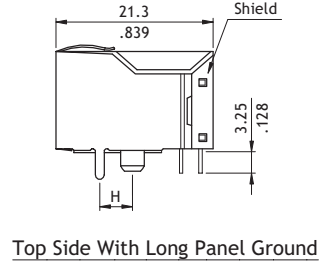
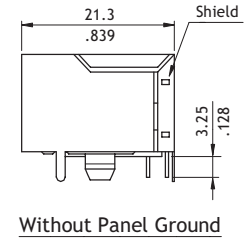
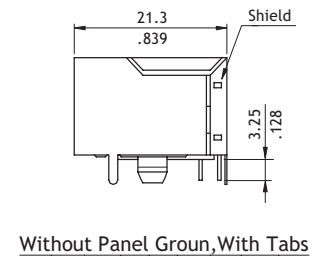
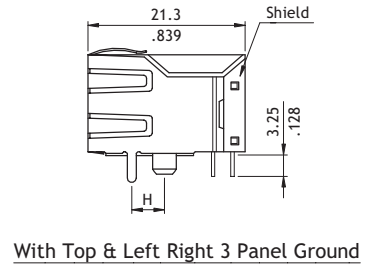
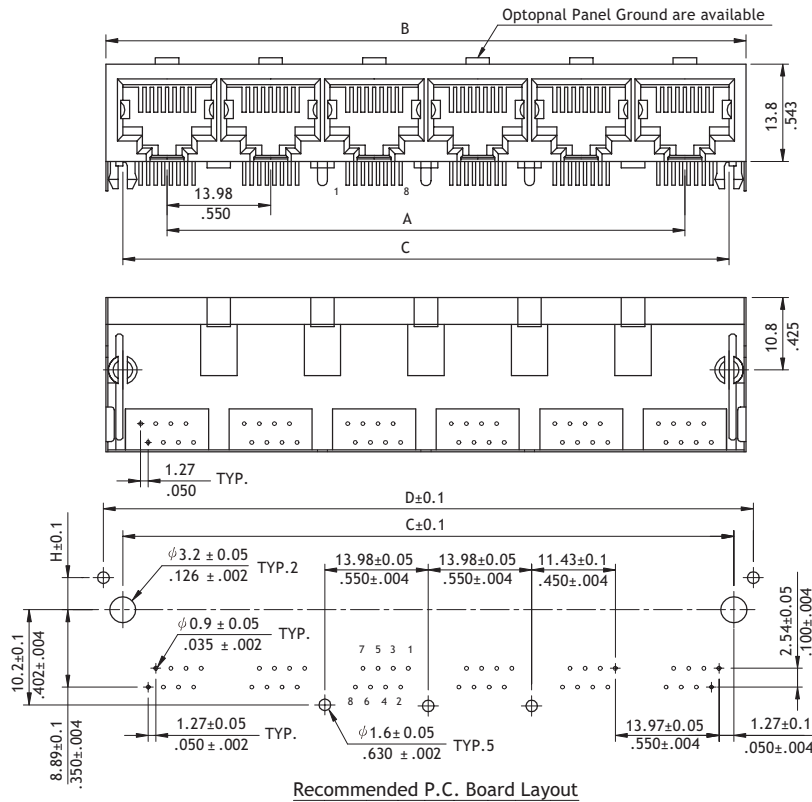

CviLux P/N	Dimension				
	A	B	C	D	H
CJ4888*11*A					4.57(.180)
CJ4888*11*B		16.0(.630)	11.43(.450)	15.55(.612)	3.65(.144)
CJ4888*11*C					3.05(.120)
CJ4888*21*A	13.98(.549)	31.0(1.220)	25.4(1.000)	30.75(1.211)	4.57(.180)
CJ4888*41*A	41.91(1.650)	59.1(2.327)	53.34(2.100)	58.9(2.319)	4.57(.180)
CJ4888*61*A	69.9(2.752)	87.25(3.435)	81.30(3.201)	86.8(3.417)	4.57(.180)
CJ4888*81*A	97.79(3.850)	114.9(4.523)	109.22(4.300)	114.6(4.512)	4.57(.180)

**Ordering Code**

① ② ③ ④ ⑤ ⑥ ⑦  
**C J 4 8 8 8 2 8 1 0 A**

- ① Series No.
- ② No. of Circuits: 88 = 8P8C
- ③ Plating Code:  
 2 = Gold flash over Nickel  
 \*Optional plating available but MOQ requested
- ④ Ports: 1, 2, 4, 6 and 8
- ⑤ Insulator Color: 1 = Color Black
- ⑥ Panel Ground Code:  
 0 = Without Panel Ground  
 F = With Top & Left Right 3 Panel Ground (only 1 & 2 Ports)  
 H = Top Side With Long Panel Ground  
 P = Without Panel Ground, With Tabs (only 4 Ports)
- ⑦ H options:  
 A: H = 4.57mm  
 B: H = 3.65 (only 1 & 2 Ports)  
 C: H = 3.05 (only 1 & 2 Ports)  
 \*Special options consult manufacturer

**CJ59 Series Board Mount Telephone Jacks**

- ⊙ Available in 6, 8 and 10 ways
- ⊙ Insulator: Black, Glass Filled polyester
- ⊙ Flammability Rating: UL 94V-0
- ⊙ Cavity confirms to FCC rules and regulations  
PART 68, SUBPART F

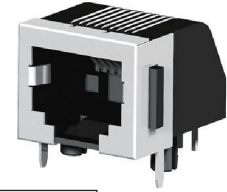

**RoHS** Compliant

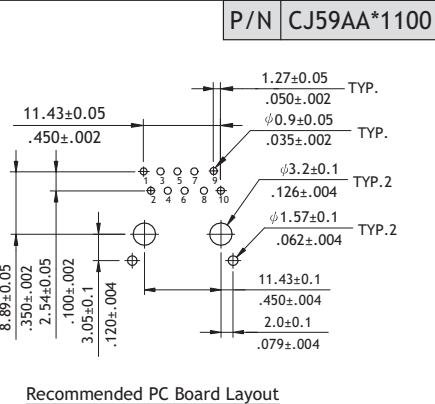
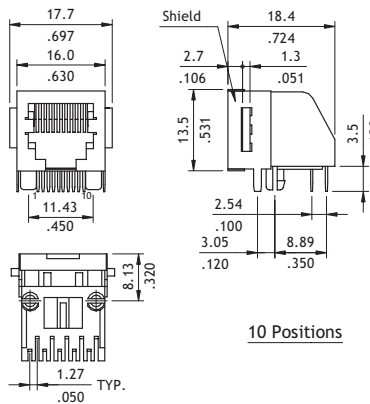
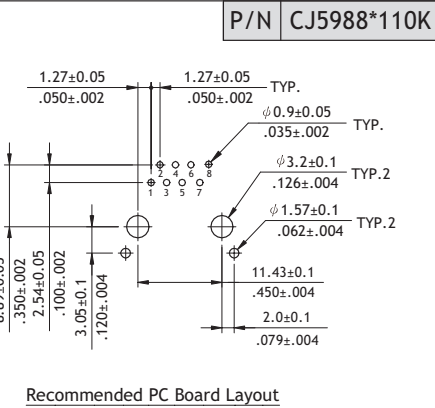
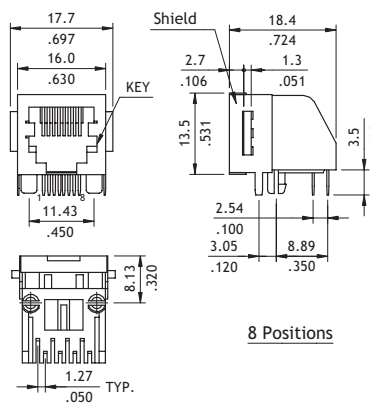
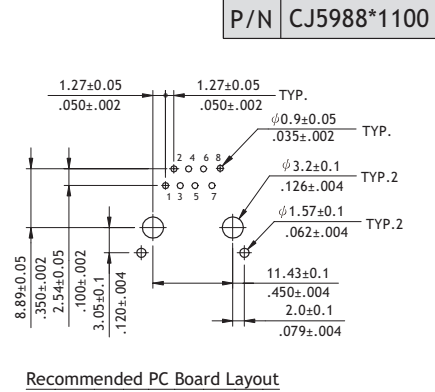
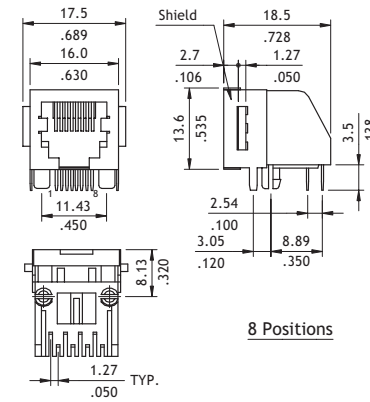
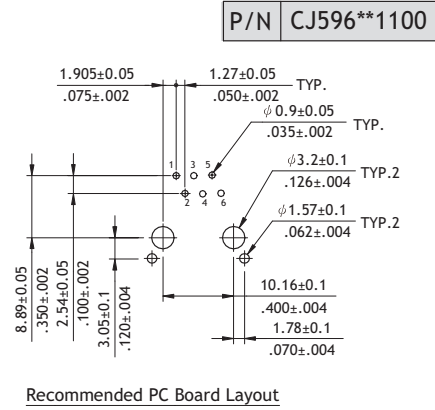
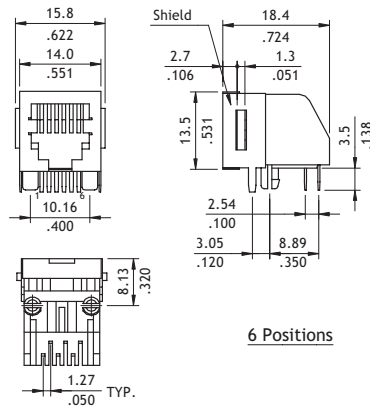

### CJ91 Series Board Mount Telephone Jacks

- ⊙ Available in 4 and 6 ways
- ⊙ Insulator: Black, Glass Filled polyester
- ⊙ Flammability Rating: UL 94V-0
- ⊙ Cavity conforms to FCC rules and regulations PART 68, SUBPART F

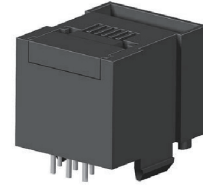

**RoHS** Compliant

P/N	CJ914**1100
-----	-------------

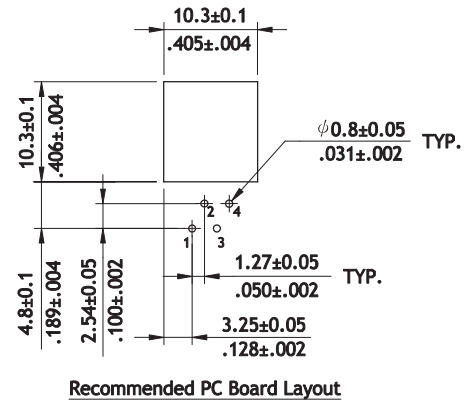
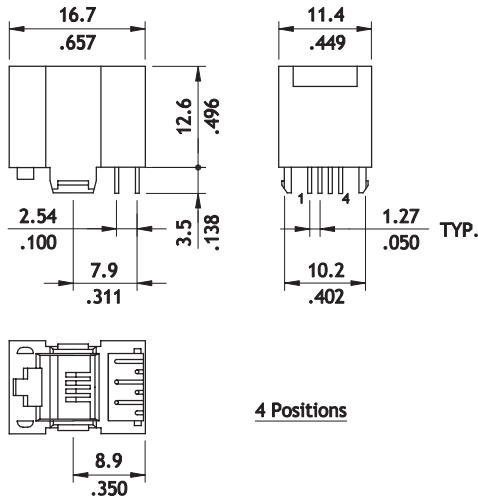

P/N	CJ916**1100
-----	-------------

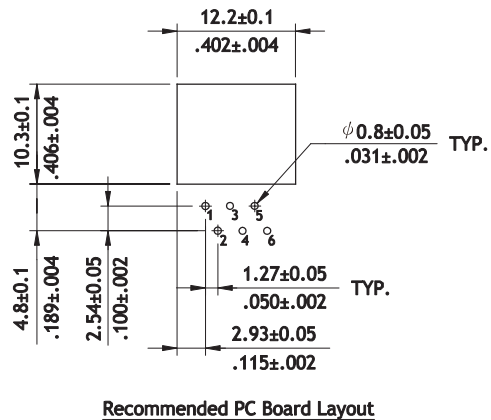
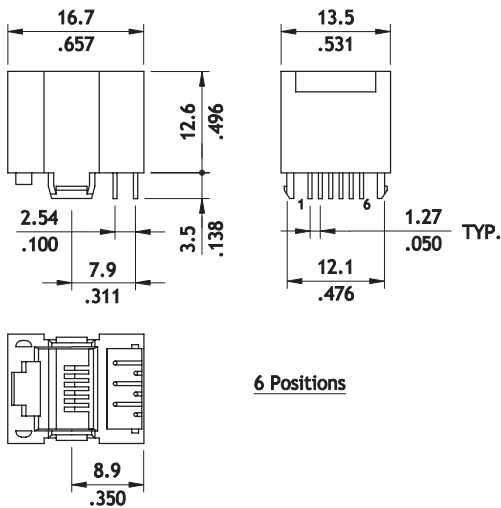

#### Ordering Code

①	②	③	④	⑤	⑥
C	J	9	1	1	00

- ① Series No.
- ② No. of Circuits: 44 = 4P4C  
42 = 4P2C ; 66 = 6P6C ; 62 = 6P2C
- ③ Plating Code:  
2 = Gold flash over Nickel
- ④ Ports : 1=1 port
- ⑤ Insulator Color: 1 = Black
- ⑥ Other Option : 00 = Standard

**CJ97 Series Board Mount Telephone Jacks**

- ⊙ Available in 4, 6 and 8 ways
- ⊙ Insulator: Black, Glass Filled polyester
- ⊙ Flammability Rating: UL 94V-0
- ⊙ Cavity confirms to FCC rules and regulations PART 68, SUBPART F

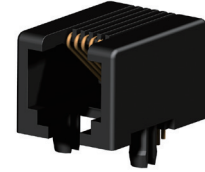

**RoHS** Compliant

**P/N CJ974\*\*1100**

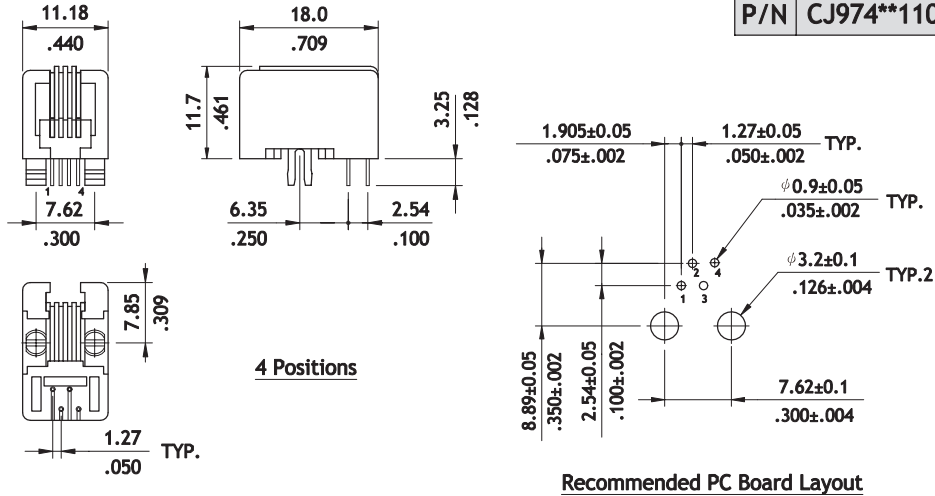

**P/N CJ976\*\*1100**

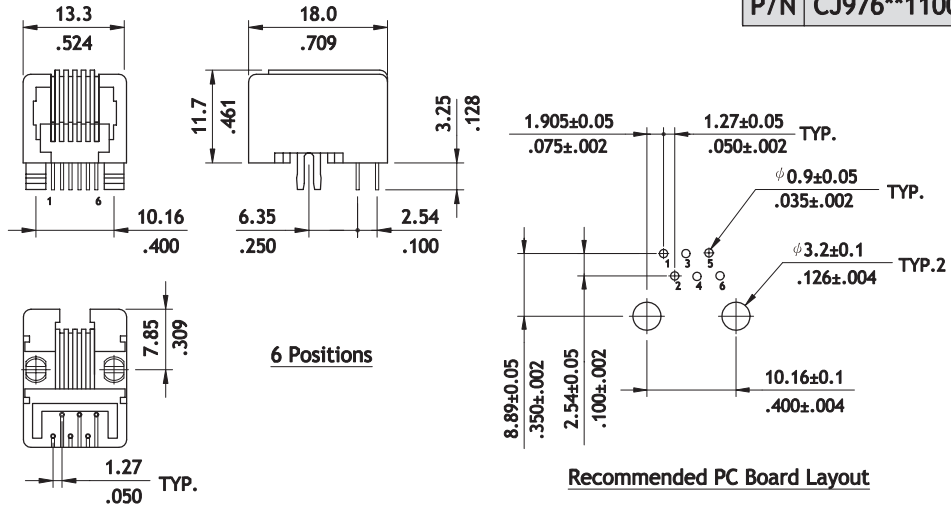

**P/N CJ9788\*1100**

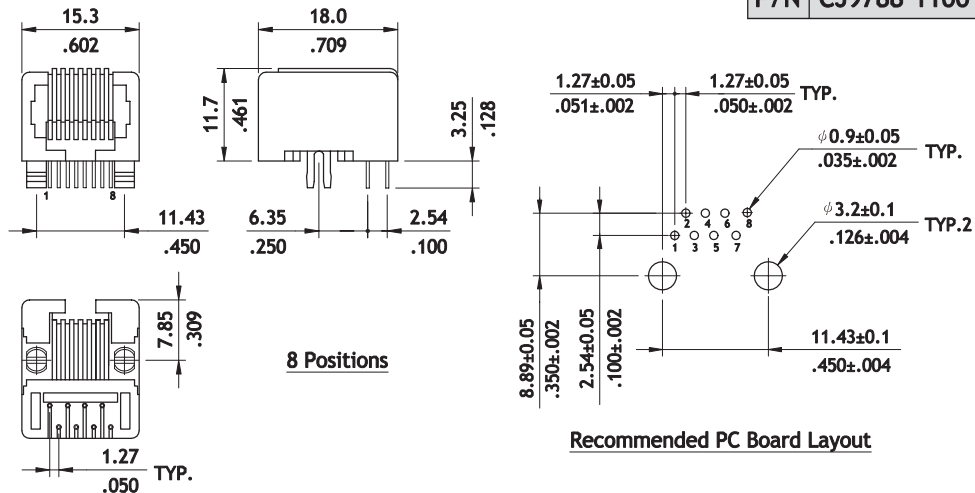

### CJ97 Series Board Mount Telephone Jacks

- ⊙ Available from in 6 and 8 ways
- ⊙ Insulator: Black, Glass Filled polyester
- ⊙ Flammability Rating: UL 94V-0
- ⊙ Cavity confirms to FCC rules and regulations PART 68, SUBPART F

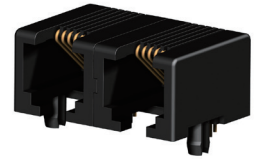

RoHS Compliant

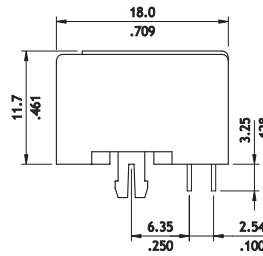
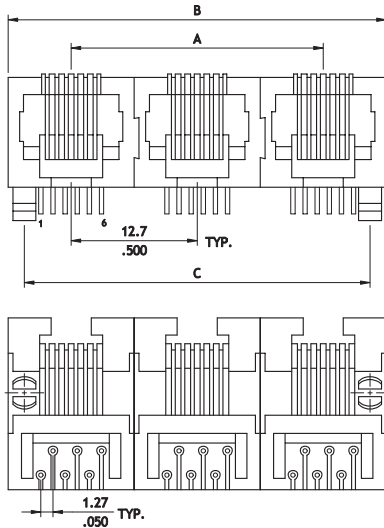

A = 12.7 \* (P-1)  
 B = 13.2 \* P - 0.5 \* (P-1)  
 C = B - 3.04  
 P = Number of Ports  
 (From 2 Prots Thru up)

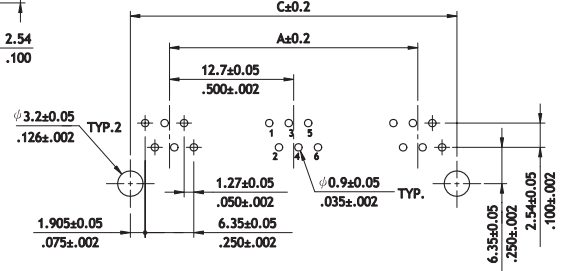

Recommended P.C. Board Layout

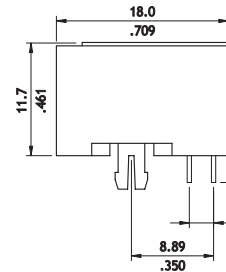
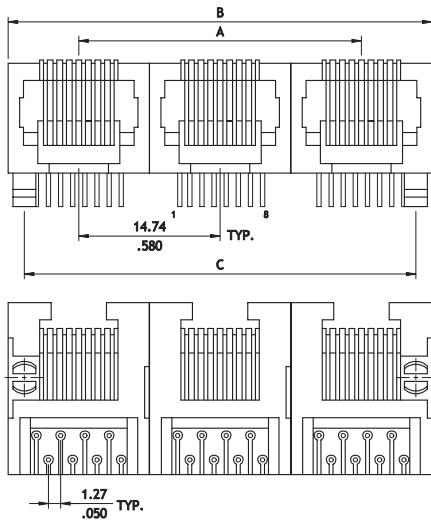

A = 14.74 \* (P-1)  
 B = 15.32 \* P - 0.5 \* (P-1)  
 C = B - 3.81  
 P = Number of Ports  
 (From 2 Prots Thru up)

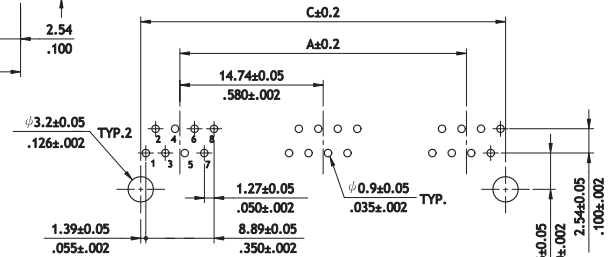

Recommended P.C. Board Layout

Ordering Code

①	②	③	④	⑤	⑥
CJ97	88	2	6	1	00

- ① Series No.
- ② No. of Circuits: 66 = 6P6C, 64 = 6P4C, 62 = 6P2C, 88 = 8P8C
- ③ Plating Code:  
 2 = Gold flash over Nickel  
 \*Optional plating available but MOQ requested
- ④ Ports: 2 to up ports
- ⑤ Insulator Color: 1 = Black
- ⑥ Panel Ground Code:  
 00 = Standard  
 \*Special options consult manufacturer

**CJP1 Series Telephone Modular Plugs**

- ⊙ Available in 4 and 6 ways
- ⊙ Plugs available for stranded or solid conductor from AWG #24~#26
- ⊙ With shielded and fits round or flat-oval cable
- ⊙ Insulator: Clear, polycarbonate

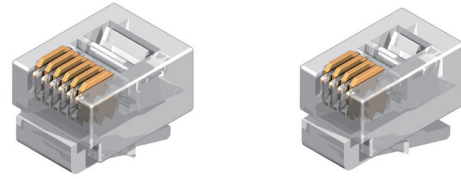

**RoHS** Compliant

**4 Positions**

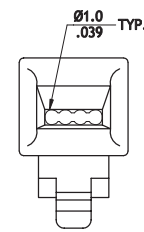
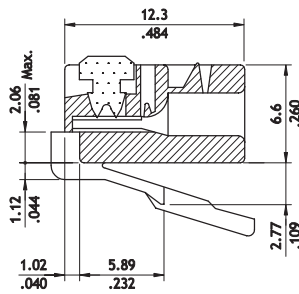
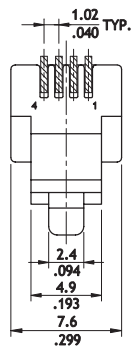

Flat-oval Cable

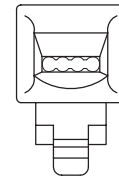

Round Cable

**6 Positions**

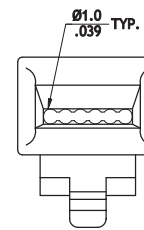
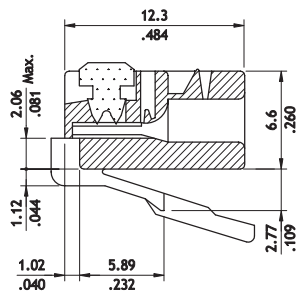
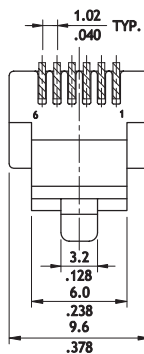

Flat-oval Cable

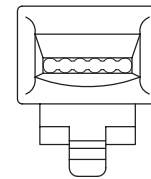

Round Cable

**Ordering Code**

① ② ③ ④ ⑤ ⑥  
**C J P 1 6 6 2 1 0 F 0**

- ① Series No.
- ② No. of Circuits: 44 = 4P4C, 42 = 4P4C  
66 = 6P6C, 64 = 6P4C  
62 = 6P2C
- ③ Plating Code:  
2 = Gold flash over Nickel  
\*Optional plating available but MOQ requested
- ④ Latch Style: 1 = Standard
- ⑤ Color Code: 0 = Nature
- ⑥ Cable Type:  
F0 = Flat-oval Cable  
R0 = Round Cable  
\*Special options consult manufacturer

### CJP2 Series Telephone Modular Plugs

- ⊙ Available in 8 and 10 ways
- ⊙ Plugs available for stranded or solid conductor from AWG #24 ~ #26
- ⊙ With shielded and fits round or flat-oval cable
- ⊙ Insulator: Clear, Polycarbonate

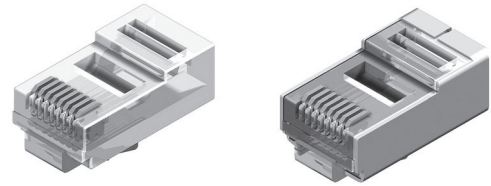

**RoHS** Compliant

#### 8 Positions

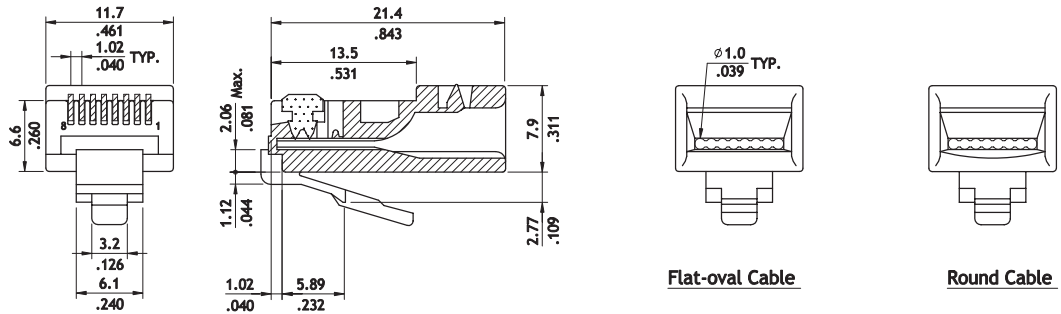

#### 8 Positions

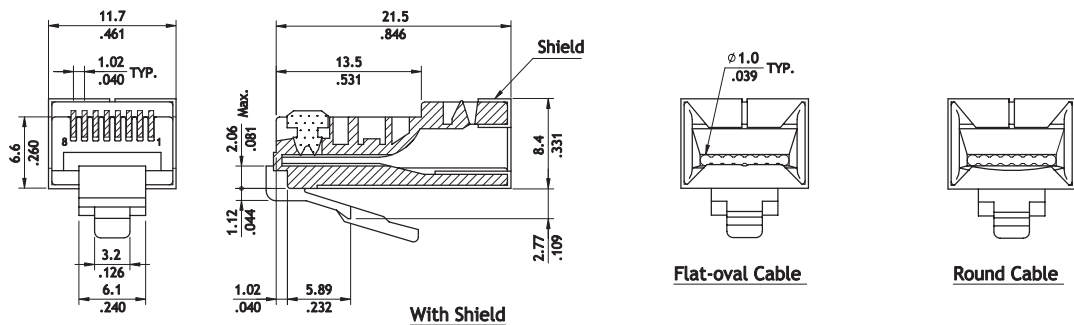

#### 10 Positions

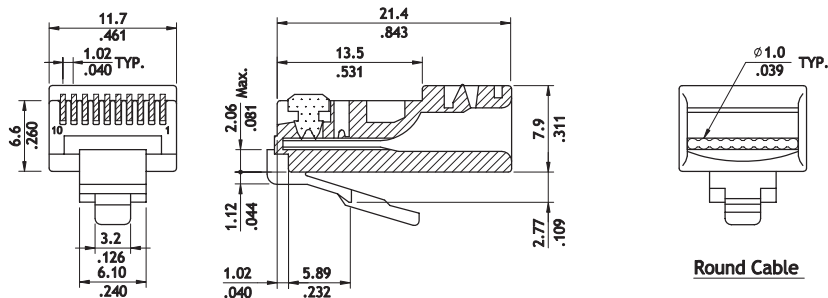

#### Ordering Code

① ② ③ ④ ⑤ ⑥ ⑦  
**C J P 2 8 8 2 1 0 R 0**

- ① Series No.
- ② No. of Circuits: 88 = 8P8C, AA = 8P10C
- ③ Plating Code:  
 2 = Gold flash over Nickel  
 \*Optional plating available but MOQ requested
- ④ Latch Style: 1 = Standard
- ⑤ Color Code: 0 = Nature
- ⑥ Cable Type:  
 F = Flat-oval cable  
 R = Round cable
- ⑦ Other Options:  
 0 = Without Shield  
 R = With Shield  
 \*Special options consult manufacturer

**CJB1 Series Telephone Modular Jack RJ45**

- ⊙ Insulator: Black, Glass Filled Polyester
- ⊙ Flammability Rating : UL 94V-0
- ⊙ Cavity Confirms to FFC rules and regulation PART 68, SUBPART F

**RoHS** Compliant

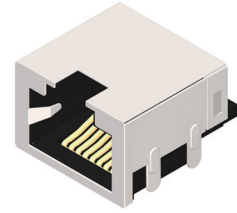

P/N	CJB188S110D
-----	-------------

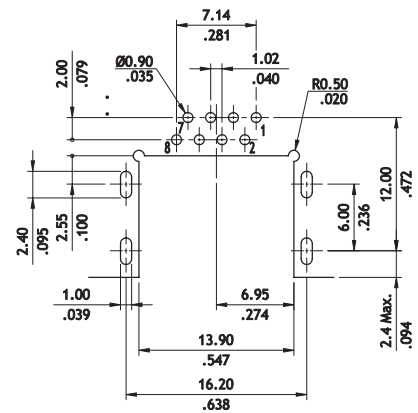
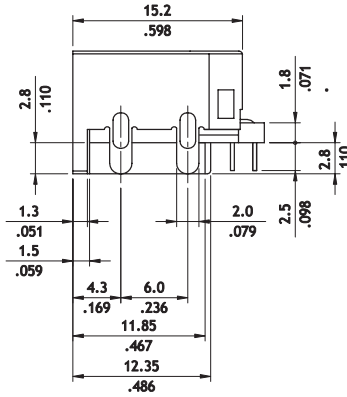
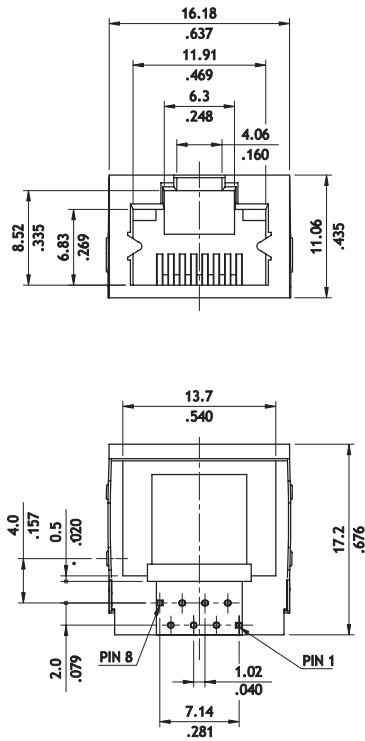

Recommended PC Board Layout  
For 1.20mm Thickness

**Ordering Code**

①	②	③	④	⑤	⑥	⑦
C	J	B	1	8	S	110D

- ① Series No.
- ② No. of Circuits: 8
- ③ Solder tails : 8 = 08
- ④ Plating Code:  
S=Contact: 50µ"Gold plated over Nicke  
Solder tails: Gold flash plated over Nickel
- ⑤ Port : 1= 1 port
- ⑥ Insulator Color : 1= Black
- ⑦ Other Options:  
0D= Without Panel Ground & LED

## CJCJ Series Telephone Modular Jack RJ45

- ⊙ Low profile and available in 8ways
- ⊙ For 10/100 Base-T application
- ⊙ Insulator : Black, Glass Filled polyester
- ⊙ Flammability Rating UL94V-0

**NEW**

**RoHS** Compliant

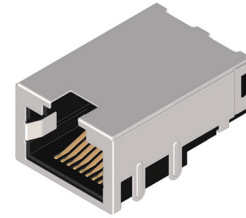

P/N **CJCJ88CA100**

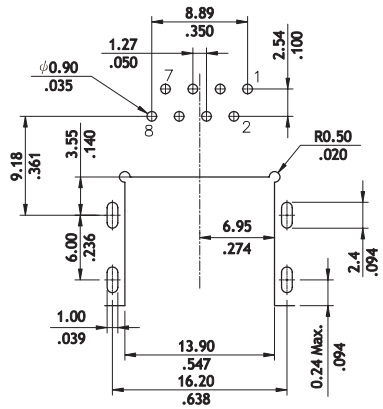
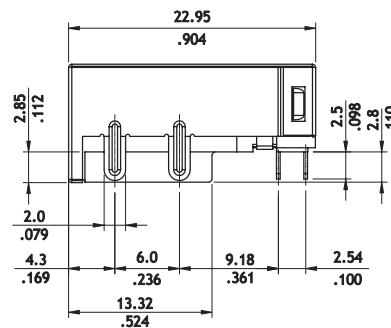
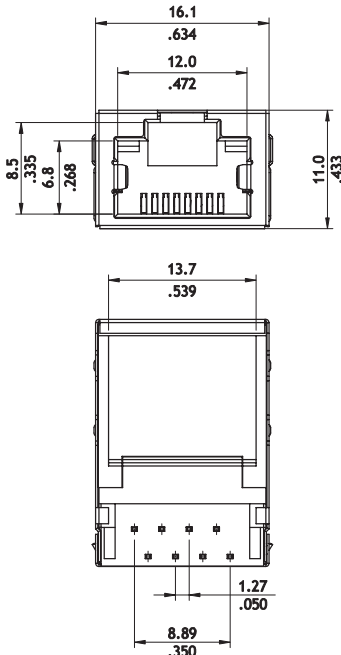

Recommended P.C. Board Layout

**Mechanical:**

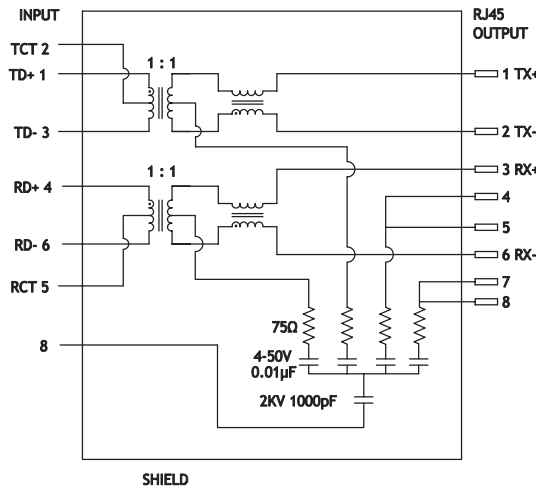

**Ordering Code**

① ② ③ ④ ⑤ ⑥ ⑦ ⑧  
**C J C J 8 8 C A 1 0 0**

- ① Series No.
- ② Contact :
- ③ Solder tails :
- ④ Plating Code: C = Selective 30μ" Gold flash over Nickel
- ⑤ Transformer Type : A=Type
- ⑥ Insulator Color : 1= Black
- ⑦ Panel Ground Options: 0= Without Panel Ground & LED
- ⑧ Other Option : 0 = Standard

**CU01 Series USB2.0 Type-A Board Mount Receptacle and SMT Plug Connectors**

- ⊙ High durability and long cycle life
- ⊙ Designed to meet the USB 2.0 specifications

RoHS Compliant  

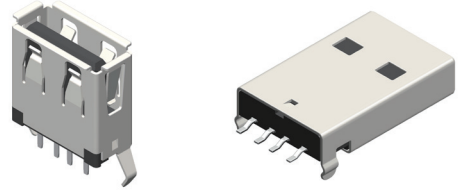

P/N CU01S\*V\*500

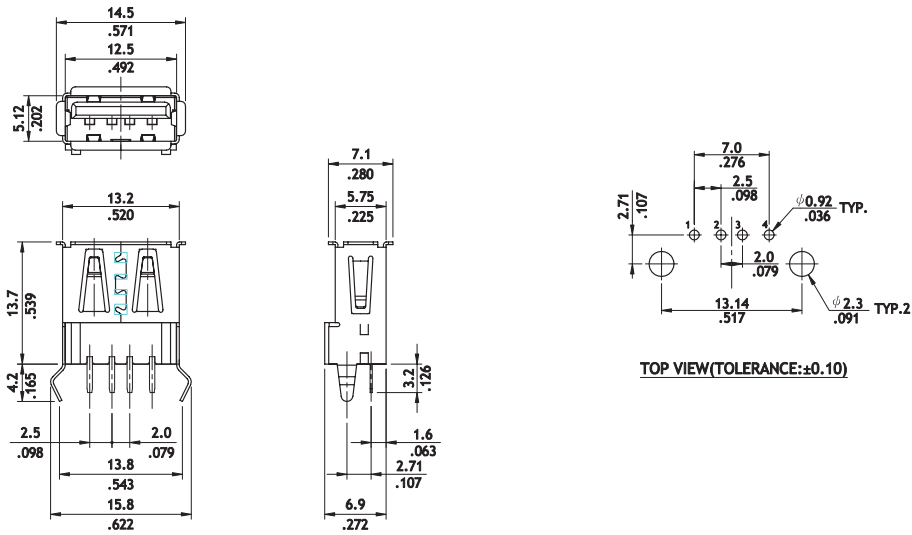

P/N CU01P\*H\*00A

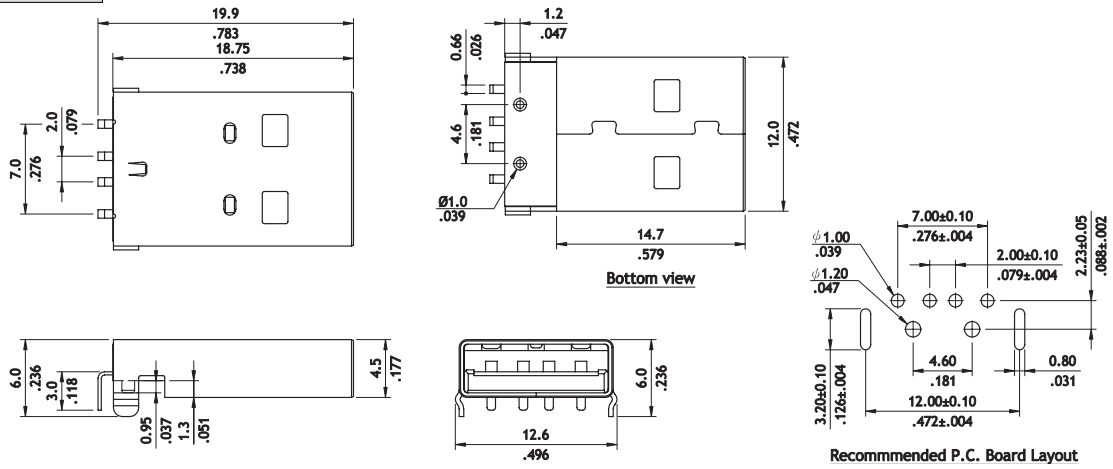

**Ordering Code**

① ② ③ ④ ⑤ ⑥ ⑦  
**CU01 S A V 0 S 00**

- ① Series No.
- ② S = Socket
- ③ Plating Code :  
 A = Selective Gold flash over Nickel  
 C = Selective 30µ" Gold flash over Nickel
- ④ V= Straight DIP
- ⑤ Insulator Color : 1= Black , 0 = White
- ⑥ S = Single port
- ⑦ Options: 00 = Standard

① ② ③ ④ ⑤ ⑥  
**CU01 P A H 1 00A**

- ① Series No.
- ② P= Plug
- ③ A = Selective Gold flash over Nickel  
 C = Selective 30µ" Gold flash over Nickel
- ④ H= Right Angle
- ⑤ Insulator Color : 1 = Black , 0 = White
- ⑥ Options: 00A = Standard

**CU01 Series USB2.0 Type-A Board Mount Receptacle Connectors**

- ⊙ High durability and long cycle life
- ⊙ Designed to meet the USB 2.0 specifications

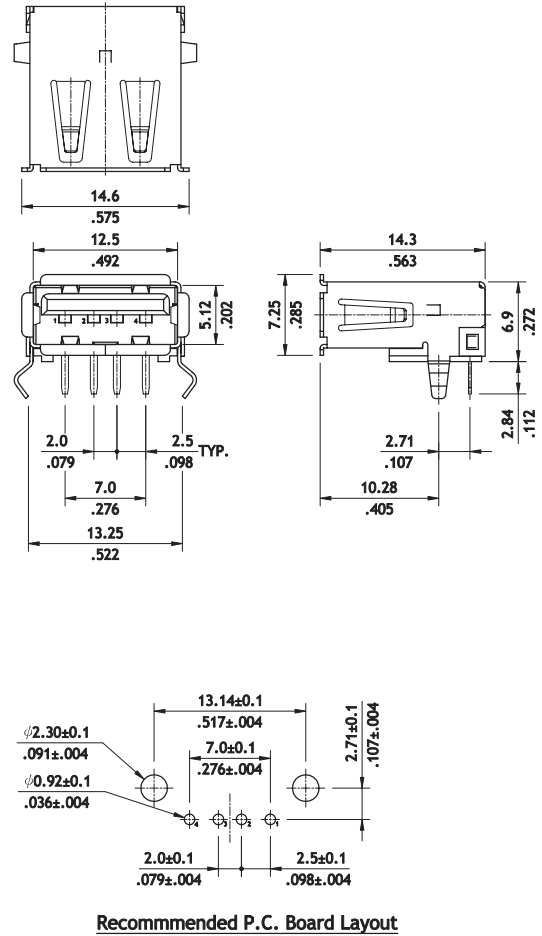
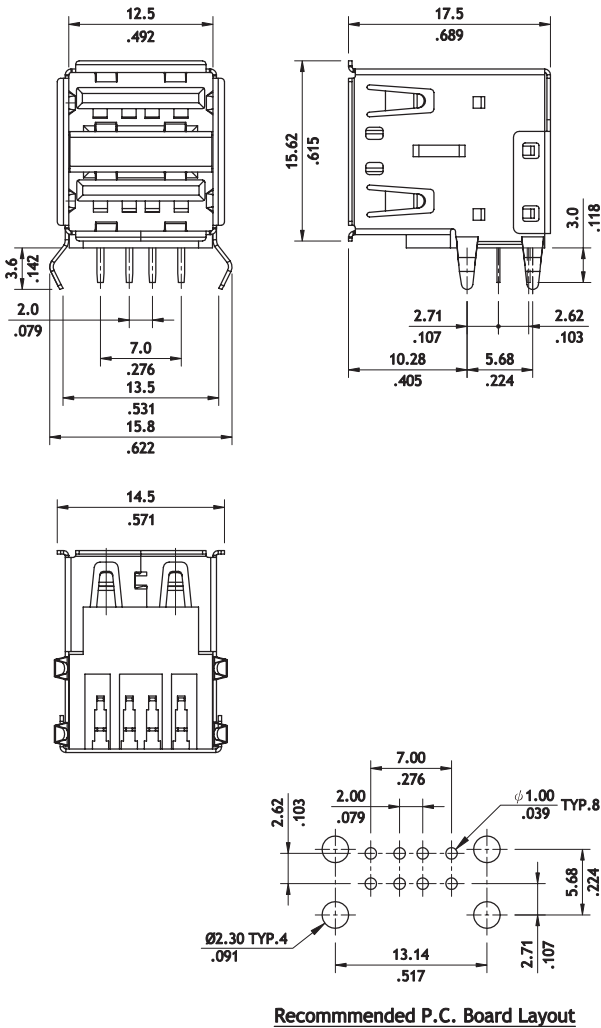
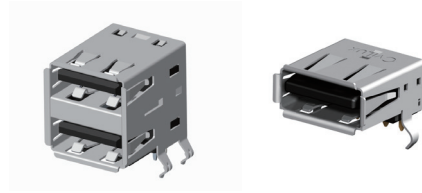

**Ordering Code**

①	②	③	④	⑤	⑥	⑦
<b>CU01</b>	<b>S</b>	<b>A</b>	<b>H</b>	<b>1</b>	<b>D</b>	<b>0C</b>

- ① Series No.
- ② S = Socket
- ③ Plating Code :  
A = Selective Gold flash over Nickel  
C = Selective 30µ" Gold flash over Nickel
- ④ H= Right Angle
- ⑤ Insulator Color : 1= Black
- ⑥ D = Dual port
- ⑦ Options: 0C = Without Spring Tab

①	②	③	④	⑤	⑥	⑦
<b>CU01</b>	<b>S</b>	<b>A</b>	<b>H</b>	<b>1</b>	<b>S</b>	<b>00</b>

- ① Series No.
- ② S = Socket
- ③ A = Selective Gold flash over Nickel  
C = Selective 30µ" Gold flash over Nickel
- ④ H= Right Angle
- ⑤ Insulator Color : 1 = Black , 0 = White
- ⑥ S = Single port
- ⑦ Options: 00 = Standard

**CU02 Series USB2.0 Type-B Board Mount Receptacle Connectors**

- ⊙ 4-position shielded receptacle connector
- ⊙ High durability and long cycle life
- ⊙ Designed to meet the USB 2.0 specifications
- ⊙ USB 2.0 Approved Test ID: 60000738

RoHS Compliant  



P/N CU02S\*V\*00\*

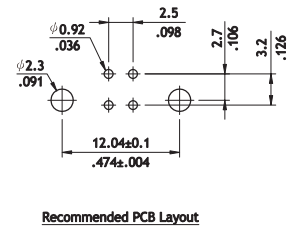
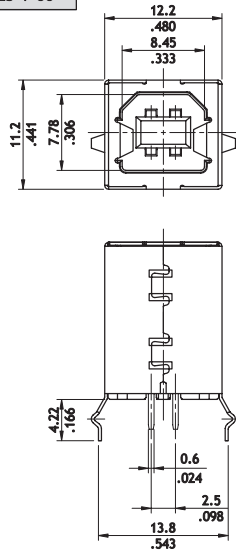

P/N CU02S\*H\*000

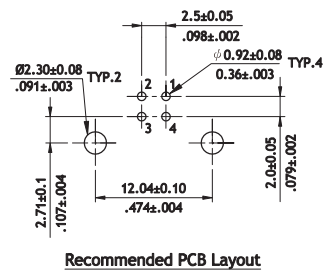
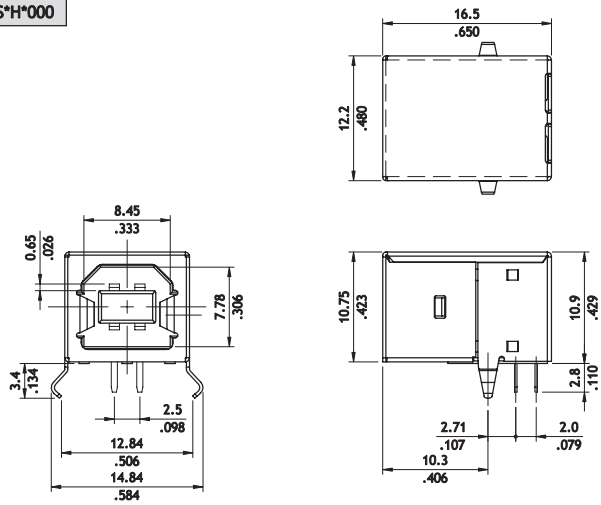

**Ordering Code**

① ② ③ ④ ⑤ ⑥  
**CU02 S A H 0 000**

- ① Series No.
- ② S = Socket
- ③ Plating Code :  
A = Selective Gold flash over Nickel
- ④ Tail Type: V = Straight DIP Type  
H = Right Angle DIP Type
- ⑤ Insulator Color: 1 = Black ; 0 = White
- ⑥ Other Option : 000=Standard

CU

I/O CONNECTOR

## CU04 Series Mini USB2.0 5 Circuits Receptacle SMT/DIP Connectors

- ⊙ High temperature plastic insulator
- ⊙ With fixed tabs and ground pegs
- ⊙ Grounding fingers provide locking feature and plug retention

RoHS Compliant

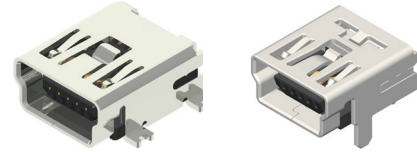

P/N CU04S\*M15B0\*0-NH

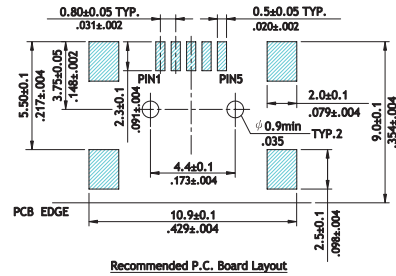
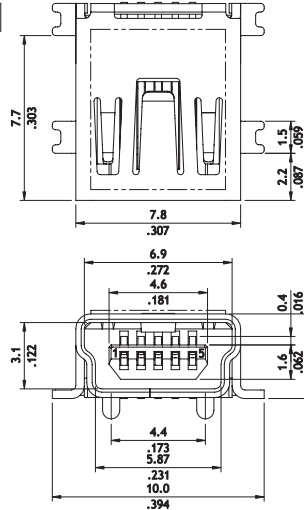

P/N CU04S\*H15BC-R0-NH

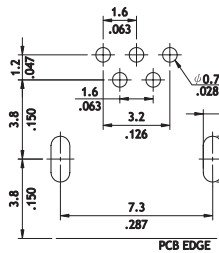
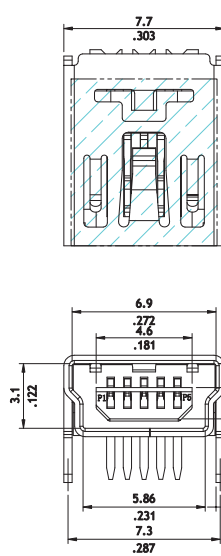

Recommended P.C. Board Layout  
TOLERANCE: ±0.05MM

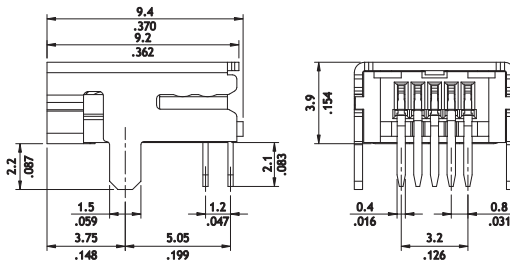

### Ordering Code

① ② ③ ④ ⑤ ⑥ ⑦ ⑧ ⑨ ⑩  
**CU04 S A M 1 5 B 0 - R0 - NH**

- ① Series No.
- ② S = Receptacle
- ③ Plating Code :  
 A = Selective Gold flash over Nickel  
 C = Selective 30µ" Gold flash over Nickel
- ④ Tail Type: M = SMT Type  
 H = Right Angle DIP Type
- ⑤ Insulator Color: 1 = Black
- ⑥ No. of Circuits: 5 Pin
- ⑦ Type: B = B Type
- ⑧ Other Option: 0 = Standard ; C = Pin Length 2.1mm
- ⑨ Packing Options:  
 R0 = Tape & Reel (with Pick & Place Pad)  
 T0 = Tube
- ⑩ NH = For Lead Free soldering process and Halogen-Free

**CU09 Series Micro USB2.0 Connectors**

- ⊙ High temperature plastic for insulator
- ⊙ High durability and long cycle life

RoHS Compliant

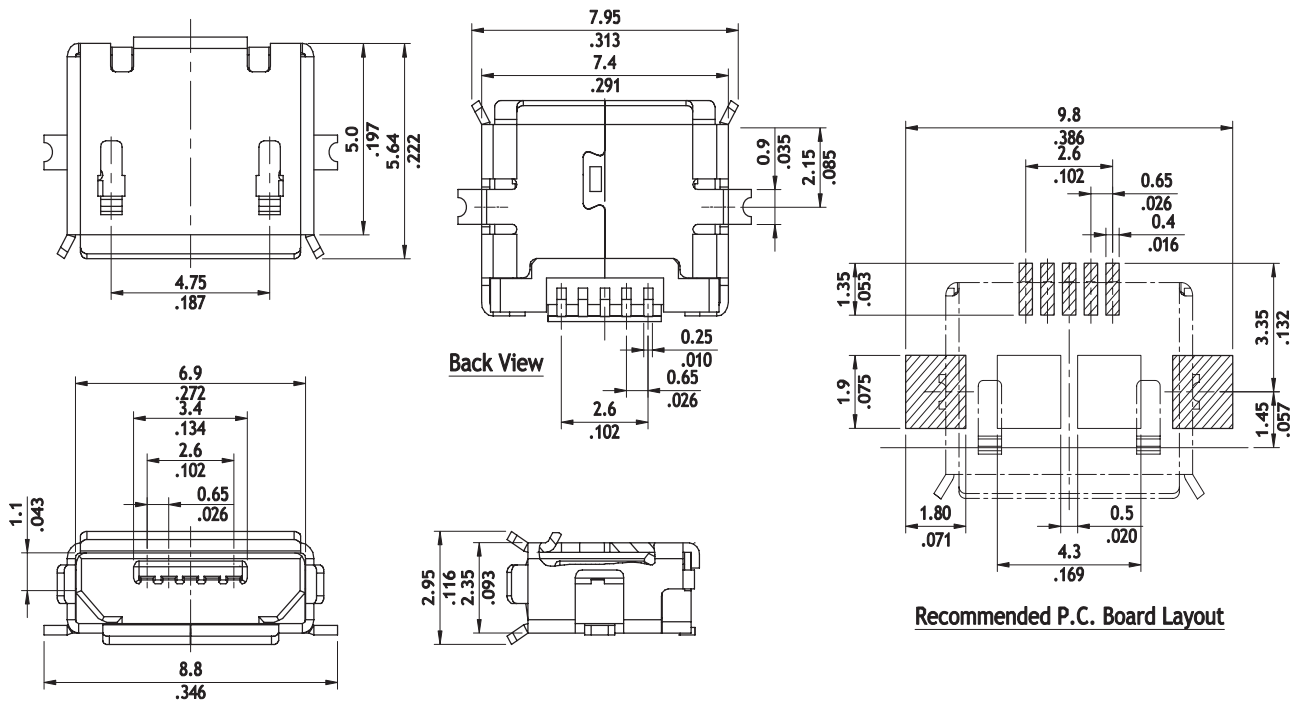
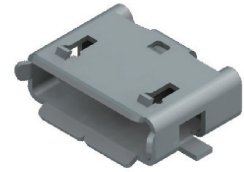

**Ordering Code**

①	②	③	④	⑤	⑥	⑦	⑧
C	U	0	9	S	2	M	1
5	C	0					

- ① Series No.
- ② S = Socket
- ③ Plating Code :  
2 = Gold flash over Nickel
- ④ Tail Type: M = SMT Type
- ⑤ Insulator Color: 1 = Black
- ⑥ No. of Circuits: 5 Pin
- ⑦ Type: C = Micro USB 5 Pin Type-AB
- ⑧ Other Options: 0 = Standard

## CU05 Series IEEE 1394 Shielded I/O Receptacle Connectors

- ⊙ Available up-right angle version
- ⊙ With ground pegs
- ⊙ Provide the interface for speeds up to 400Mbs
- ⊙ Full metal shielding for ESD protection
- ⊙ High temperature plastic housing for SMT processing
- ⊙ Gold plated leaf contact withstand up to 1500 cycles
- ⊙ Polarized box shell design and lock grounding finger sensure plug retention

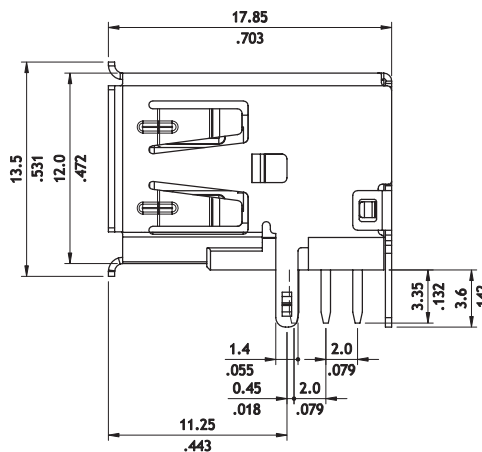
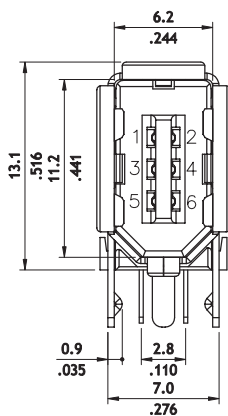
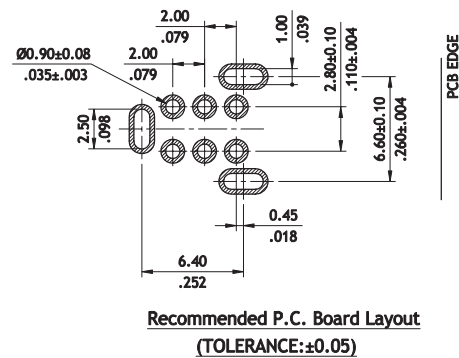
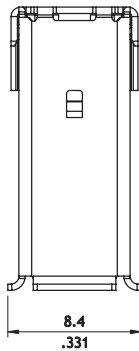
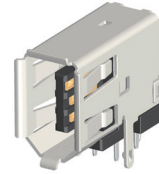

### Ordering Code

① ② ③ ④ ⑤ ⑥ ⑦ ⑧ ⑨  
**CU05 S C H 1 U D0 - R0 - NH**

- ① Series No.
- ② S = Socket
- ③ Plating Code :  
C = Selective 30µ" Gold flash over Nickel  
\*Optional plating available but MOQ requested
- ④ Tail Type: H = Side Entry

- ⑤ Insulator Color: 1 = Black
- ⑥ Type: U = Upright Type
- ⑦ Options: D0 = Standard
- ⑧ Packing Option : R0 =Reel Packing
- ⑨ NH = For Lead Free wave flow soldering process and Halogen-Free

**CU11 Series HDMI Receptacle Connectors**

- ⊙ High temperature plastic insulator
- ⊙ With ground pegs

RoHS Compliant 

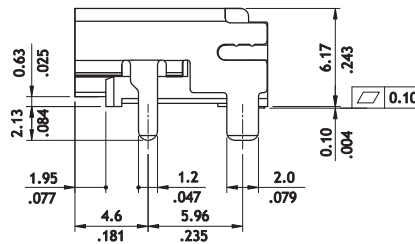
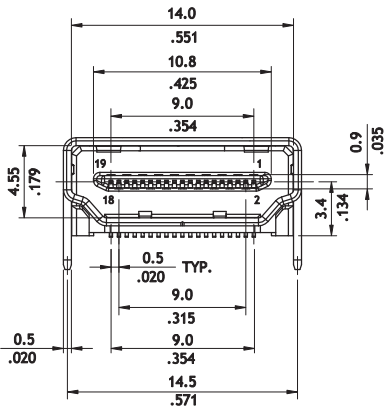
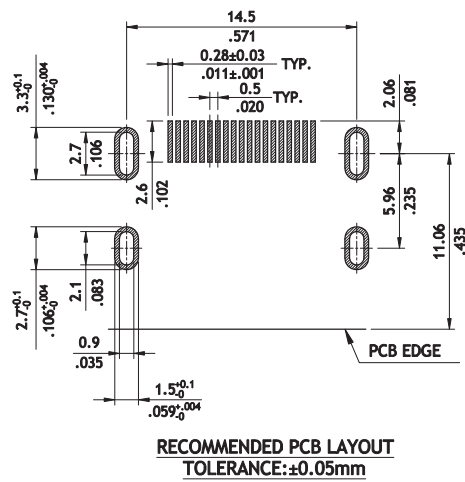
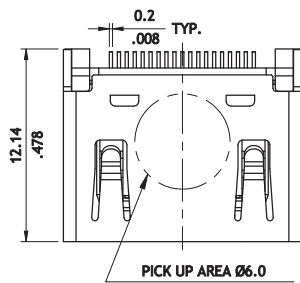

**Ordering Code**

① ② ③ ④ ⑤ ⑥ ⑦  
**CU11 S A M 1 0E0 - R0**

- ① Series No.
- ② S = Socket
- ③ Plating Code :  
A = Selective Gold flash over Nickel
- ④ Tail Type: M = SMT Type
- ⑤ Insulator Color: 1 = Black
- ⑥ 0E0 = Standard
- ⑦ R0 = Tape & Reel

CU

I/O CONNECTOR

**USB 3.1 Type C Technical Specifications**

**NEW**

**Electrical Data-**

- Current rating: 3/5 Amps max
- Dielectric Withstanding: 100 VAC for one minute
- Contact Resistance:<40mΩ
- Insulation Resistance:>100MΩ
- Operating Temperature:-40°C to +80°C

PLUG

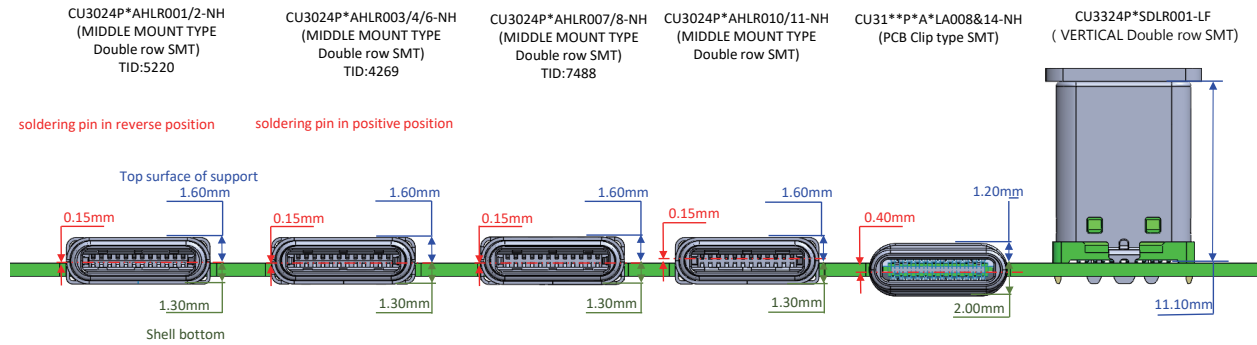

MIDDLE MOUNT TYPE

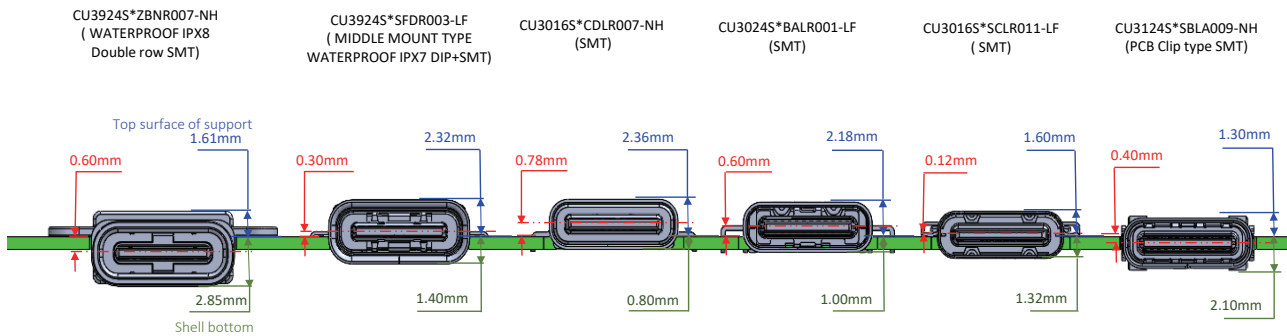

CU

I/O CONNECTOR

USB 3.1Type C Technical Specifications

**NEW**

**Electrical Data-**

- Current rating: 5 Amps max
- Dielectric Withstanding: 100 VAC for one minute
- Contact Resistance:<40mΩ
- Insulation Resistance:>100MΩ
- Operating Temperature:-40°C to +80°C

TOP MOUNT TYPE

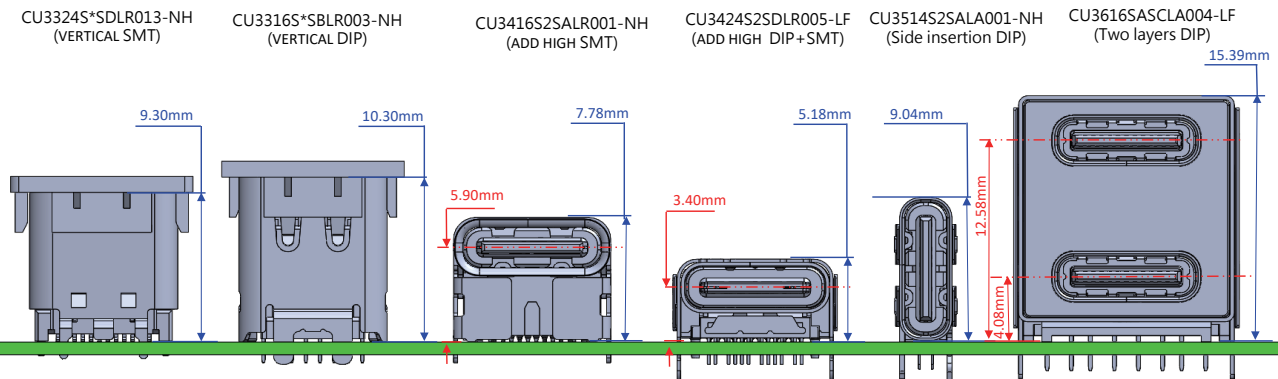
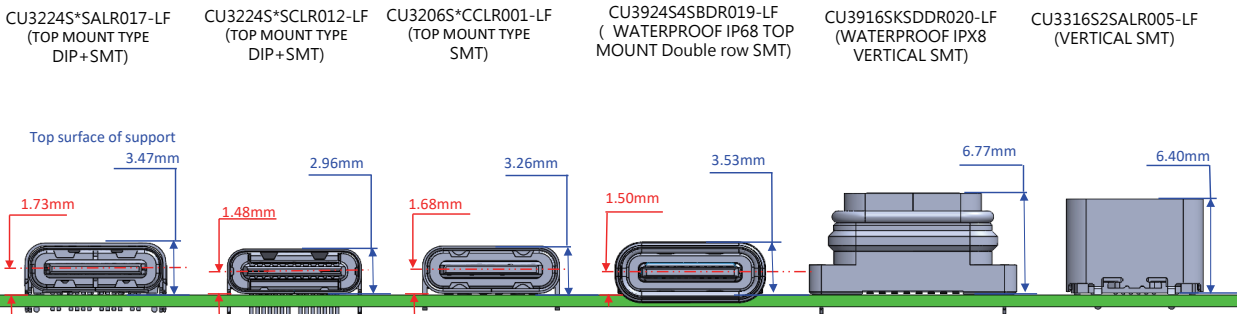
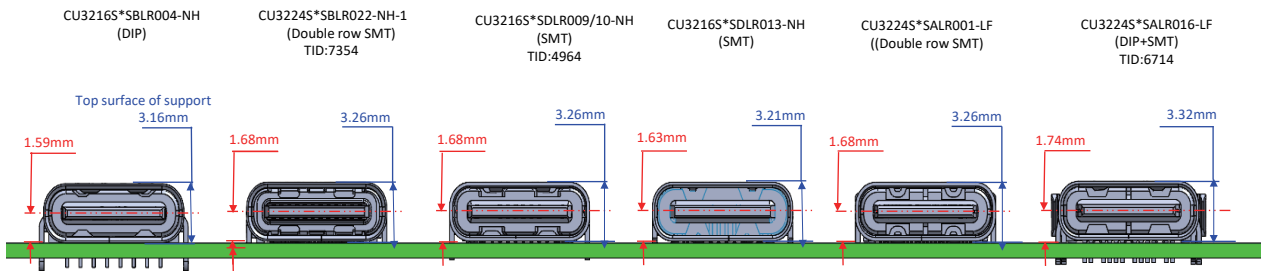

CU

I/O CONNECTOR

**CU30 Series USB 3.1 Type C Plug SMT Type Connectors (Parallel pin position)**

- ⊙ Middle Mount Type
- ⊙ High temperature plastic insulator
- ⊙ Contact current rating:3Amperes max
- ⊙ Dielectric strength:100V AC.
- ⊙ Durability cycles:10000 cycles.
- ⊙ Compatible with wire and PCB side

**NEW**



**RoHS** Compliant

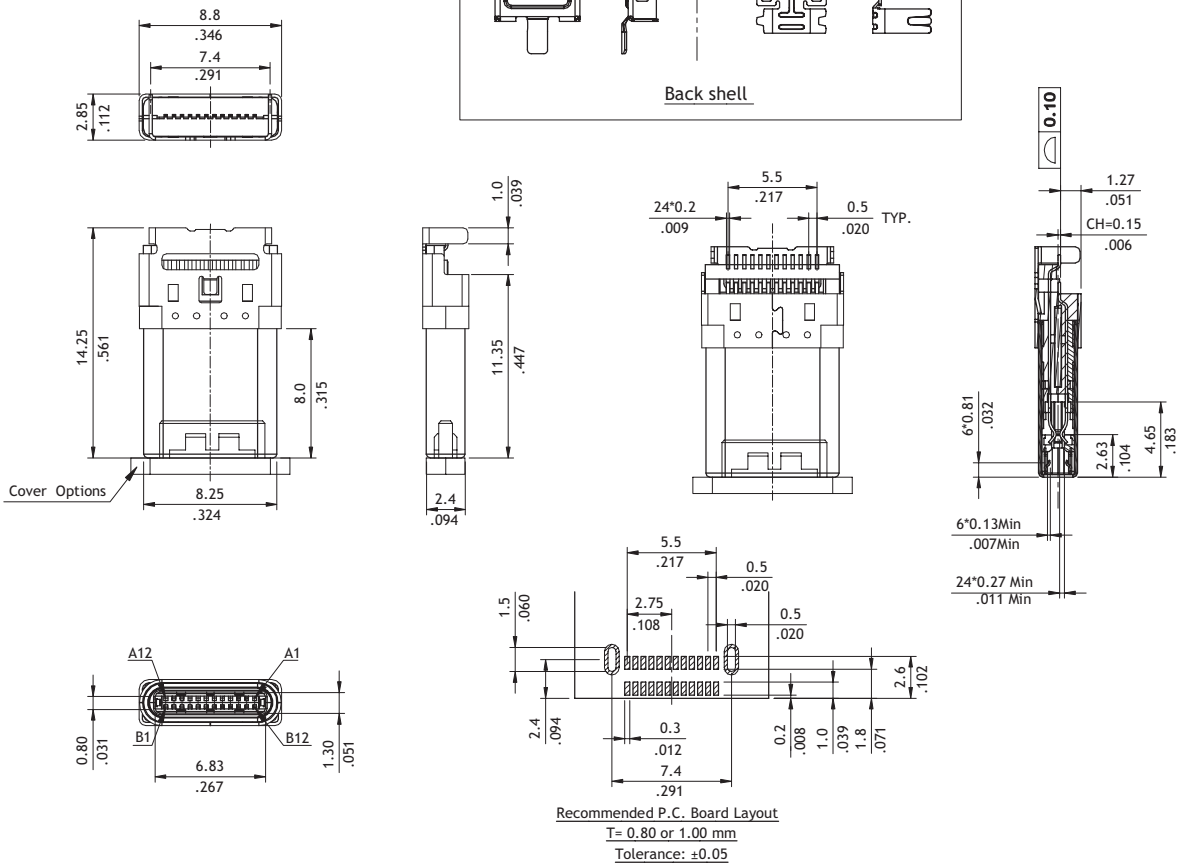
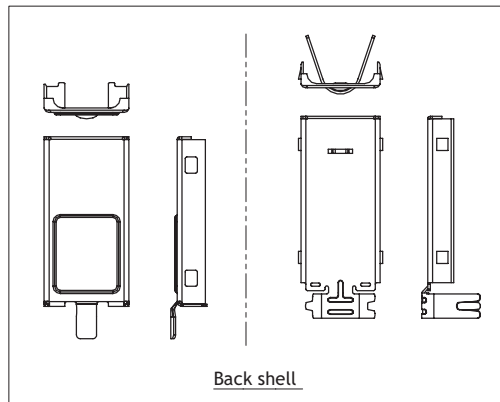

**Ordering Code**

① ② ③ ④ ⑤ ⑥ ⑦ ⑧ ⑨ ⑩  
**CU30 24 P A A H L R 003 - NH**

- ① Series No.
- ② No. of Circuits
- ③ P = Plug
- ④ Plating Code  
 A=Selective Gold Flash over Nickel  
 B=Selective 15µ" Gold flash over Nickel  
 C=Selective 30µ" Gold flash over Nickel
- ⑤ Shell Material & Plating  
 A= Stainless Steel Nickel Plating
- ⑥ Contact Material : H = Copper Alloy
- ⑦ Insulator Material & Color option  
 L= LCP , Black
- ⑧ Packing R =Tape & Reel
- ⑨ 003=Without Cover  
 004=With Cover  
 006=With cover attach Back shell
- ⑩ NH = For Lead Free soldering process and Halogen-Free  
 \*Special options consult manufacturer

CU

I/O CONNECTOR

**CU30 Series USB 3.1 Type C Plug SMT Type Connectors**

- ⊙ Middle Mount Type
- ⊙ High temperature plastic insulator
- ⊙ Contact current rating :3 Amperes max
- ⊙ Dielectric strength:100V AC.
- ⊙ Durability cycles:10000 cycles.
- ⊙ Compatible with wire and PCB side

**NEW**



RoHS Compliant (HF) (Pb) (TID)

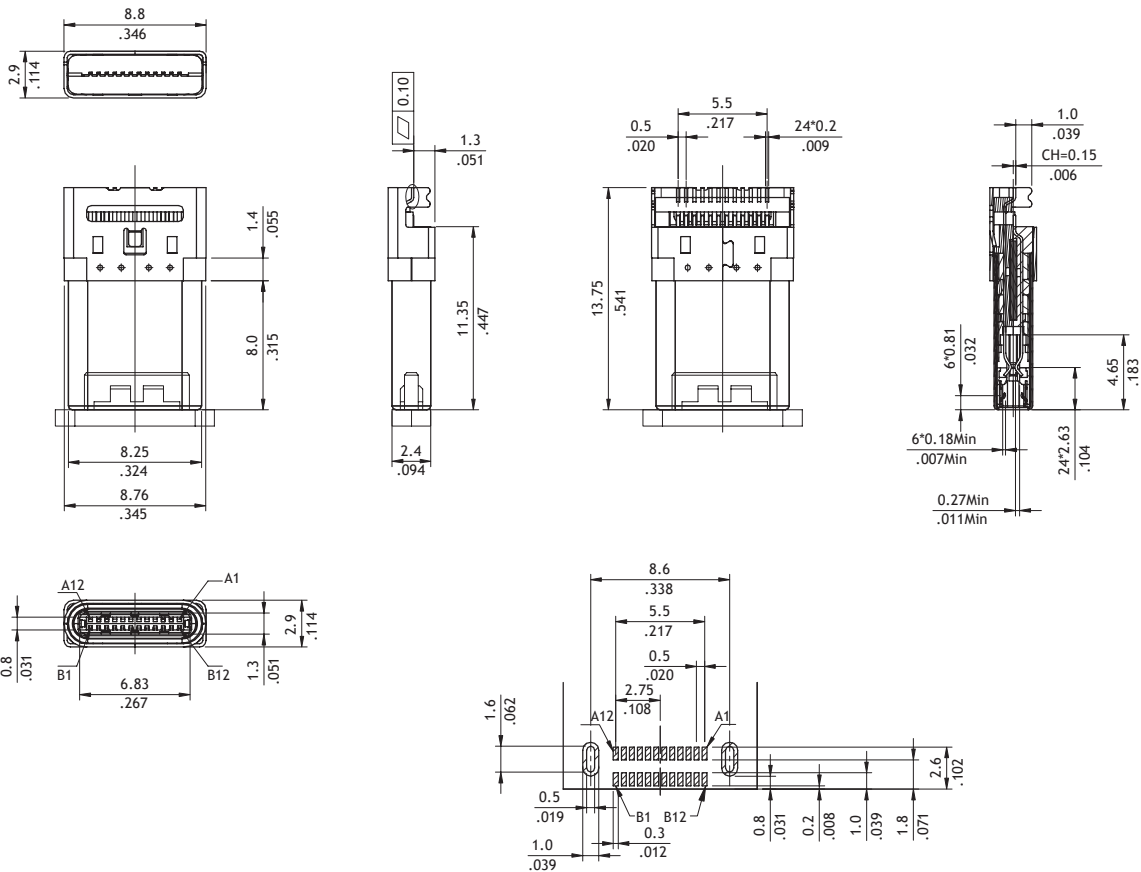

Recommended P.C.B board Layout  
 T= 0.80 or 1.00 mm  
 Tolerance: ±0.05

**Ordering Code**

① ② ③ ④ ⑤ ⑥ ⑦ ⑧ ⑨ ⑩  
**CU30 24 P A A H L R 007 - NH**

- ① Series No.
- ② No. of Circuits
- ③ P = Plug
- ④ Plating Code :  
 A=Selective Gold Flash over Nickel  
 B=Selective 15µ" Gold flash over Nickel  
 C=Selective 30µ" Gold flash over Nickel
- ⑤ Shell Material & Plating  
 A= Stainless Steel Nickel Plating
- ⑥ Contact Material : H = Copper Alloy
- ⑦ Insulator Material & Color option  
 L= LCP , Black
- ⑧ Packing : R =Tape & Reel
- ⑨ 007=With Cover  
 008=Without cover
- ⑩ NH = For Lead Free soldering process and Halogen-Free

CU

I/O CONNECTOR

## CU30 Series USB 3.1 Type C Plug SMT Type Connectors

**NEW**

- ⊙ Middle Mount Type
- ⊙ High temperature plastic insulator
- ⊙ Contact current rating:3 Amperes max
- ⊙ Dielectric strength:100V AC.
- ⊙ Durability cycles:10000 cycles.
- ⊙ Compatible with wire and PCB side

RoHS Compliant

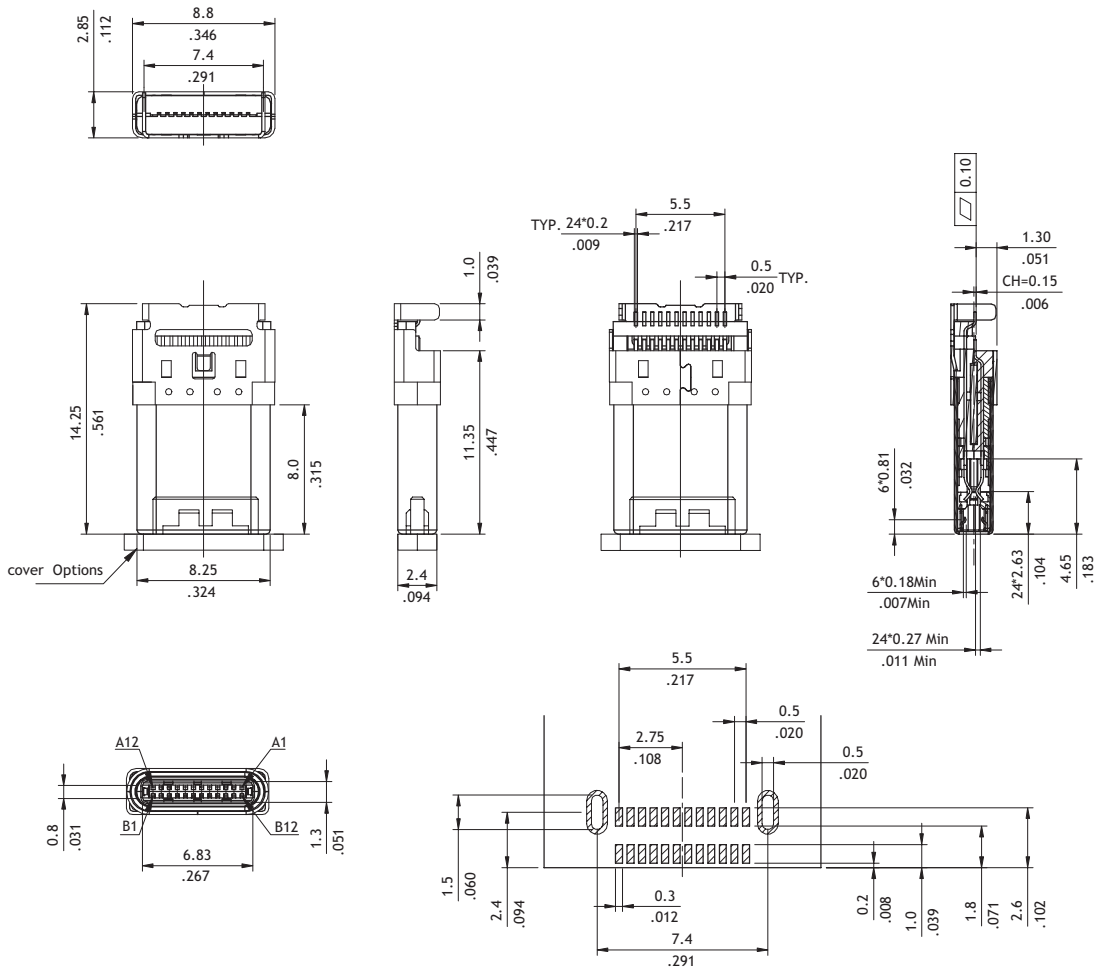
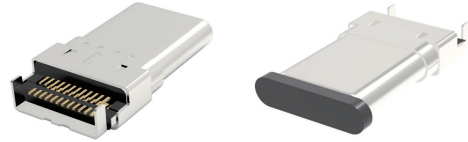

Recommended P.C. Board Layout  
 T= 0.80 or 1.00 mm  
 Tolerance: ±0.05

### Ordering Code

① ② ③ ④ ⑤ ⑥ ⑦ ⑧ ⑨ ⑩  
**CU30 24 P A A H L R 010 - NH**

- ① Series No.
- ② No. of Circuits
- ③ P = Plug
- ④ Plating Code :  
 A=Selective Gold Flash over Nickel  
 B=Selective 15μ" Gold flash over Nickel  
 C=Selective 30μ" Gold flash over Nickel
- ⑤ Shell Material & Plating  
 A= Stainless Steel Nickel Plating
- ⑥ Contact Material : H = Copper Alloy
- ⑦ Insulator Material &Color option  
 L= LCP , Black
- ⑧ Packing : R =Tape & Reel
- ⑨ Other Oprion :  
 010 = Without cover  
 011 = With cover
- ⑩ NH = For Lead Free soldering process and Halogen-Free

CU

I/O CONNECTOR

**CU30 Series USB 2.0 Type C Receptacle SMT Type Connectors**

- ⊙ Middle Mount Type
- ⊙ High temperature plastic insulator
- ⊙ Contact current rating : 5 Amperes max
- ⊙ Dielectric strength:100V AC.
- ⊙ Durability cycles:10000 cycles.



RoHS Compliant

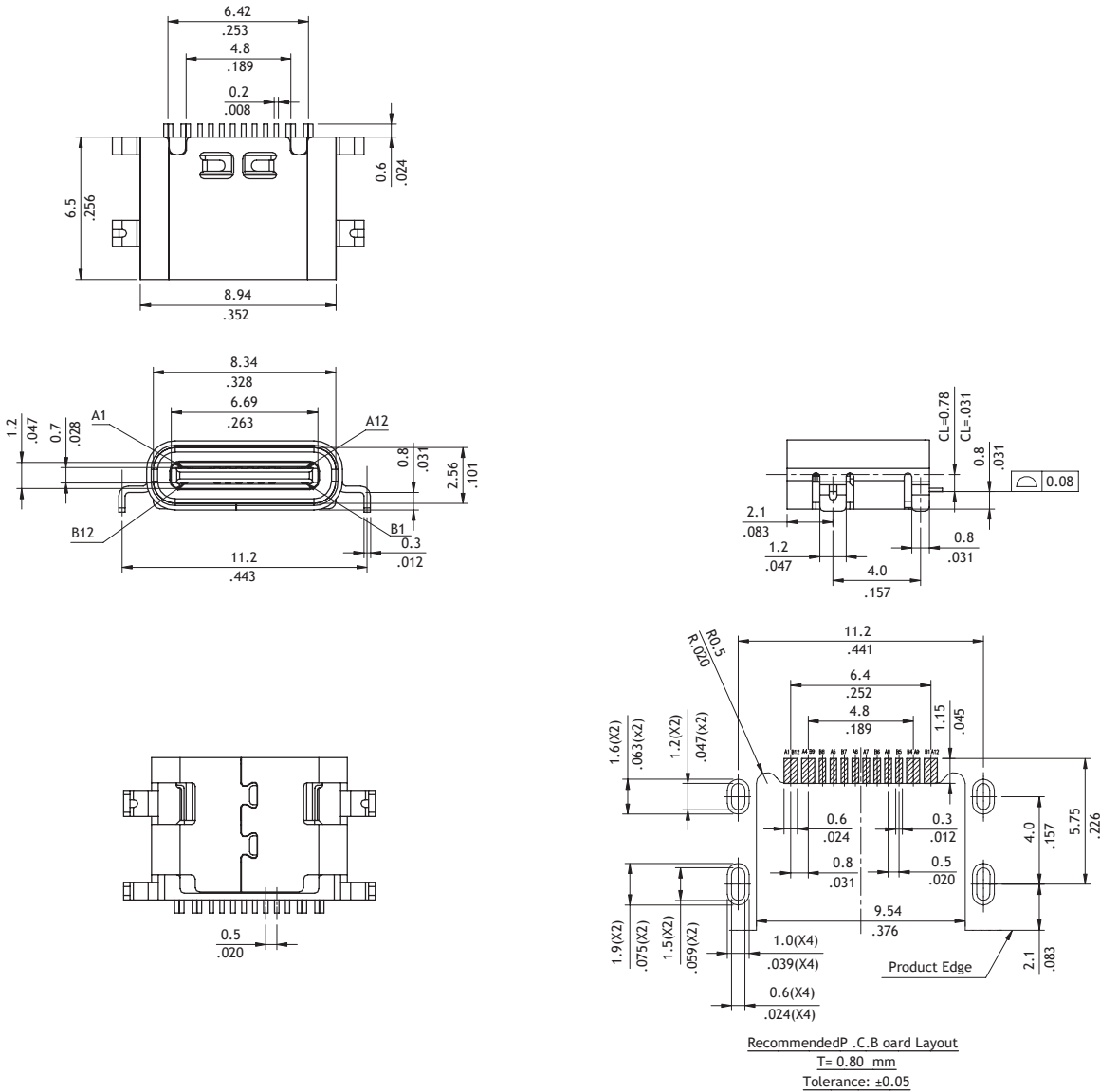

CU

**Ordering Code**

① ② ③ ④ ⑤ ⑥ ⑦ ⑧ ⑨ ⑩  
**CU30 16 S 2 C D L R 007 - NH**

- ① Series No.
- ② No. of Circuits
- ③ S = Socket
- ④ Plating Code :  
2 = Gold Flash over Nickel
- ⑤ Shell Material & Plating  
C= Stainless Steel
- ⑥ Contact Material : D = Copper Alloy
- ⑦ Insulator Material & Color option  
L= LCP , Black
- ⑧ Packing : R = Tape & Reel
- ⑨ Other Option : 007
- ⑩ NH = For Lead Free soldering process and Halogen-Free

I/O CONNECTOR

## CU30 Series USB 3.1 Type C Receptacle SMT Type Connectors

- ⊙ Middle Mount Type
- ⊙ High temperature plastic insulator
- ⊙ Contact current rating : 3 Amperes max
- ⊙ Dielectric strength:100V AC.
- ⊙ Durability cycles:10000 cycles.

**NEW**

RoHS Compliant

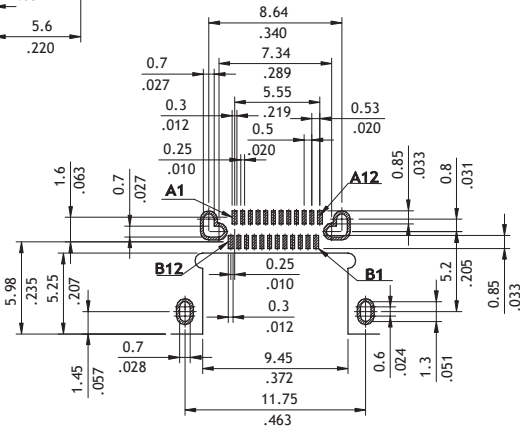
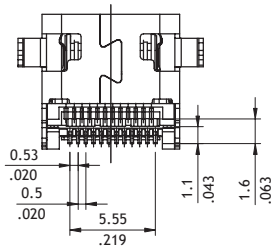
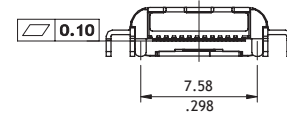
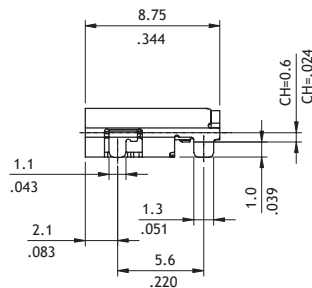
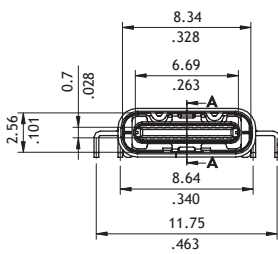
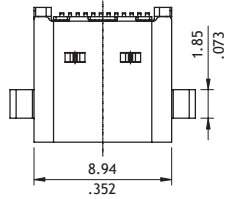
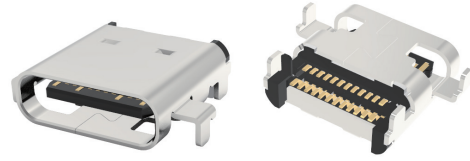

Recommended P.C.B board Layout  
T= 1.00mm  
Tolerance: ±0.05

### Ordering Code

① ② ③ ④ ⑤ ⑥ ⑦ ⑧ ⑨ ⑩  
**CU30 24 S A B A L R 001 - LF**

- ① Series No.
- ② No. of Circuits
- ③ S = Socket
- ④ Plating Code :  
 A=Selective Gold Flash over Nickel  
 B=Selective 15µ" Gold flash over Nickel  
 C=Selective 30µ" Gold flash over Nickel
- ⑤ Shell Material & Plating  
 B= Stainless Steel
- ⑥ Contact Material : A = Copper Alloy
- ⑦ Insulator Material & Color option  
 L= LCP , Black
- ⑧ Packing : R = Tape & Reel
- ⑨ Other Option : 001
- ⑩ LF = For Lead Free Soldering process

CU

I/O CONNECTOR

**CU31 Series USB 3.1 Type C Plug Clamp Type Connectors**

**NEW**

- ⊙ Clamp Plate Type
- ⊙ High temperature plastic insulator
- ⊙ Contact current rating : 5 Amperes max
- ⊙ Dielectric strength:100V AC.
- ⊙ Durability cycles:10000 cycles.



RoHS Compliant  

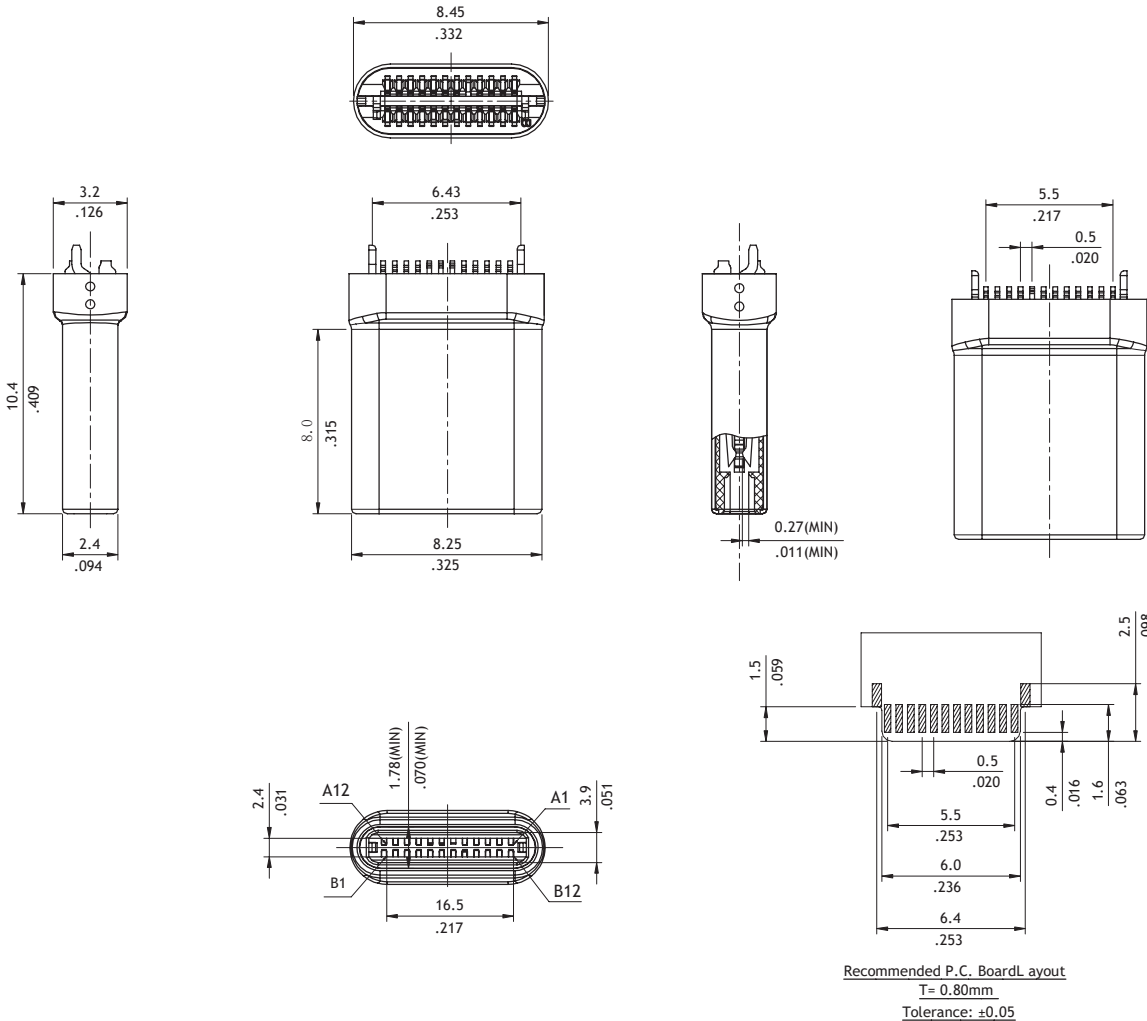

**Ordering Code**

① ② ③ ④ ⑤ ⑥ ⑦ ⑧ ⑨ ⑩  
**CU31 24 P A A C L A 008 - NH**

- ① Series No.
- ② No. of Circuits:12,16,24
- ③ P = Plug
- ④ Plating Code :  
 A=Selective Gold Flash over Nickel  
 B=Selective 15μ" Gold flash over Nickel  
 C=Selective 30μ" Gold flash over Nickel
- ⑤ Shell Material & Plating  
 A= Stainless Steel Nickel Plating  
 C = Selective 30μ" Gold flash over Nickel
- ⑦ Insulator Material &Color option  
 L= LCP , Black
- ⑧ Packing : A = Tray
- ⑨ Other Oprion : 008
- ⑩ NH = For Lead Free soldering process and Halogen-Free  
 \*Special options consult manufacturer

CU

I/O CONNECTOR

## CU31 Series USB 3.1 Type C Receptacle Type Connectors

- ⊙ Clamp Plate Type
- ⊙ High temperature plastic insulator
- ⊙ Contact current rating : 5 Amperes max
- ⊙ Dielectric strength:100V AC.
- ⊙ Durability cycles:10000 cycles.

**NEW**

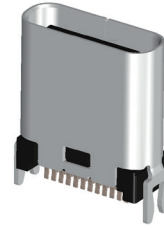

RoHS Compliant

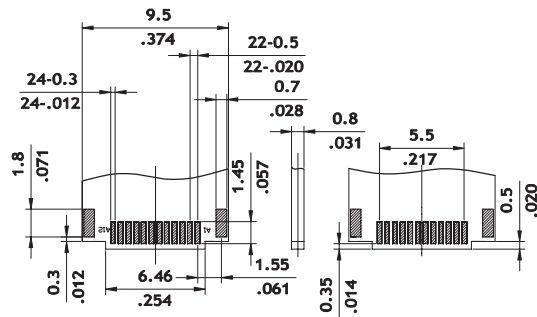
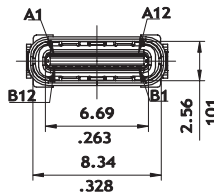
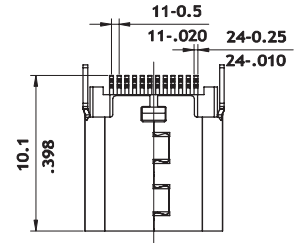
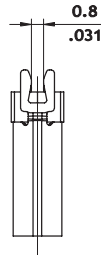
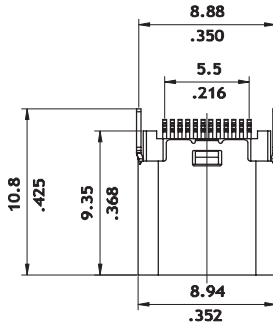
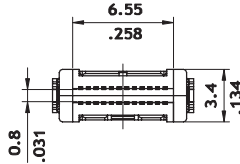

Recommended P.C.B board Layout

T= 0.80 mm

Tolerance: ±0.05

### Ordering Code

① CU ② 31 ③ 24 ④ S ⑤ A ⑥ S ⑦ B ⑧ L ⑨ A ⑩ 009 - NH

- |   |  |
|---|--|
| <ul style="list-style-type: none"> <li>① Series No.</li> <li>② No. of Circuits : 24</li> <li>③ S = Socket</li> <li>④ Plating Code :<br/>A=Selective Gold Flash over Nickel<br/>J=Selective 3μ" Gold flash over Nickel</li> <li>⑤ Shell Material &amp; Plating<br/>S=Stainless Steel Nickel Plating</li> </ul> | <ul style="list-style-type: none"> <li>⑥ Contact Material: B = Cooper Alloy</li> <li>⑦ Insulator Material &amp;Color option<br/>L= LCP , Black</li> <li>⑧ Packing : A = Tray</li> <li>⑨ Other Oprion : 008</li> <li>⑩ NH = For Lead Free soldering process and Halogen-Free<br/>*Special options consult manufacturer</li> </ul> |
|---|--|

**CU32 Series USB Type C Receptacle SMT Type Connectors**

- ⊙ Top Mount Type
- ⊙ High temperature plastic insulator
- ⊙ Contact current rating : 3 Amperes max
- ⊙ Dielectric strength:100V AC.
- ⊙ Durability cycles:10000 cycles.

**NEW**

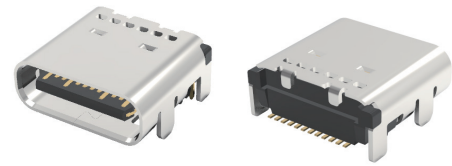

RoHS Compliant

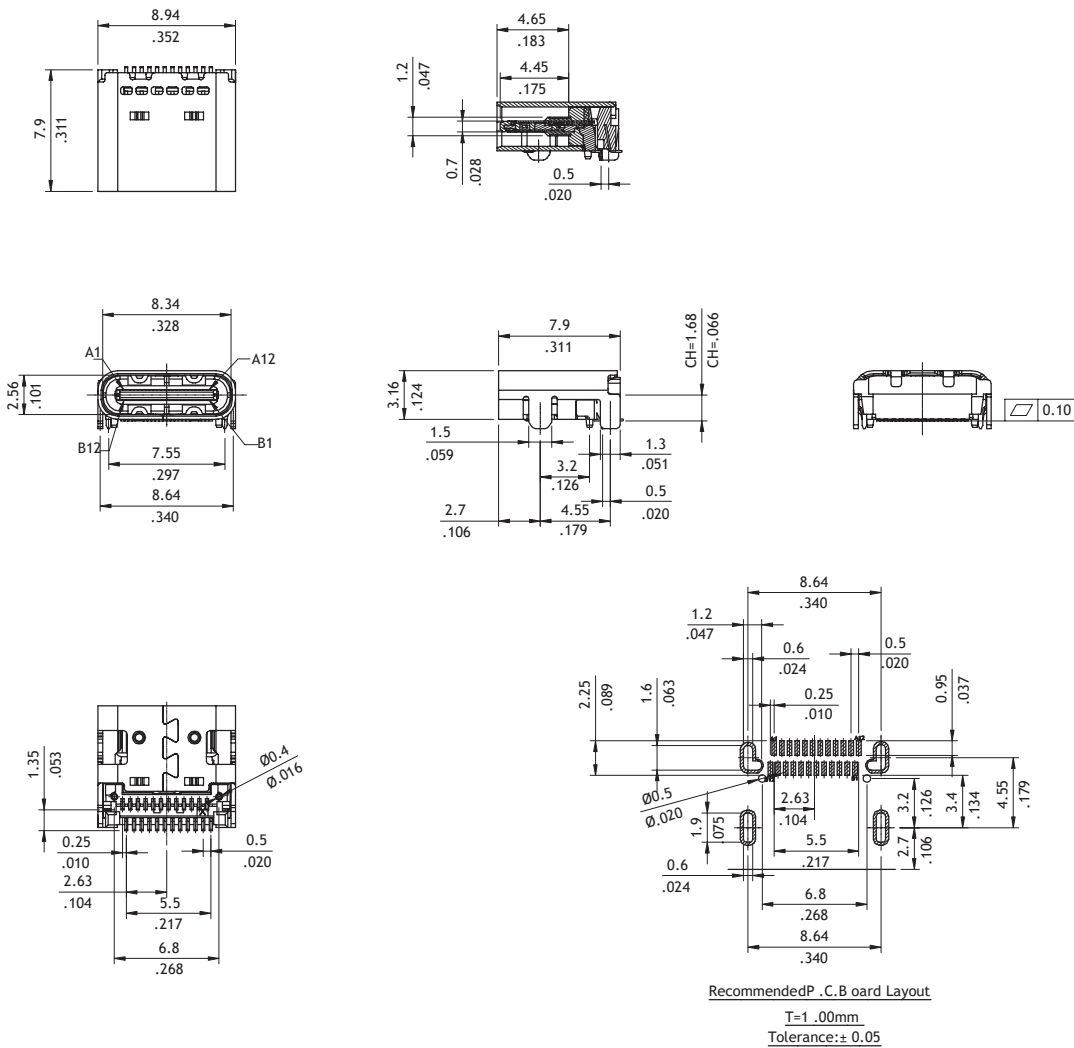

**Ordering Code**

① ② ③ ④ ⑤ ⑥ ⑦ ⑧ ⑨ ⑩  
**CU32 24 S A S A L R 001 - LF**

- ① Series No.
- ② No. of Circuits : 24
- ③ S = Socket
- ④ Plating Code :  
A=Selective Gold Flash over Nickel
- ⑤ Shell Material & Plating: S= Stainless Steel
- ⑥ Contact Material : A=Copper Alloy
- ⑦ Insulator Color : L = LCP , Black
- ⑧ Packing : R=Tape & Reel
- ⑨ Other Option : 001
- ⑩ LF = For Lead Free Soldering process

CU

I/O CONNECTOR



**CU32 Series USB Type C Receptacle SMT Type Connectors**

- ⊙ Top Mount Type + SMT Type
- ⊙ High temperature plastic insulator
- ⊙ Contact current rating : 5 Amperes max
- ⊙ Dielectric strength:100V AC.
- ⊙ Durability cycles:10000 cycles

**NEW**

RoHS Compliant 

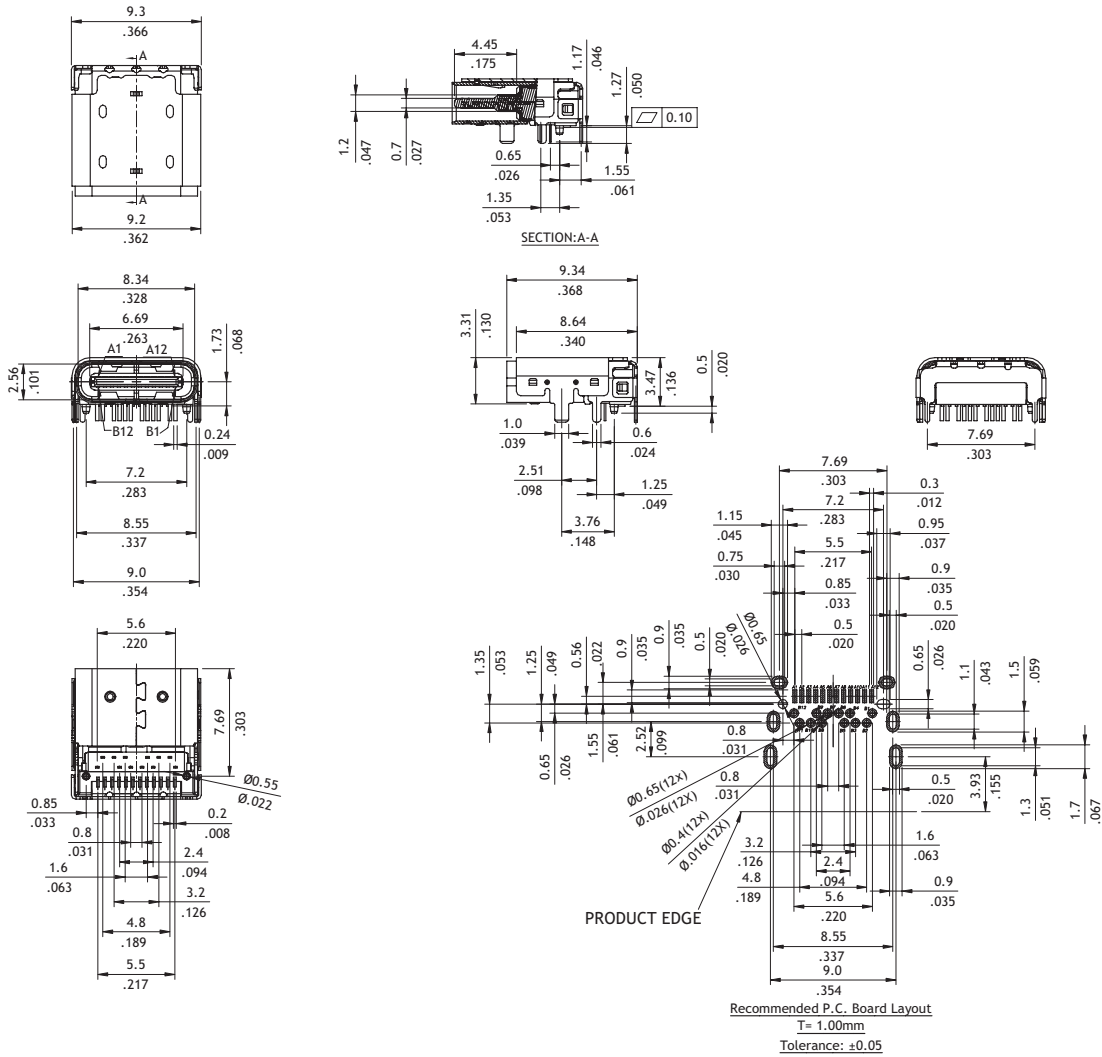

**Ordering Code**

① ② ③ ④ ⑤ ⑥ ⑦ ⑧ ⑨ ⑩  
**CU32 24 S 2 S A L R 017 - LF**

- ① Series No.
- ② No. of Circuits
- ③ S = Socket
- ④ Plating Code :  
2=Selective Gold Flash over Nickel
- ⑤ Shell Material & Plating: S= Stainless Steel
- ⑥ Contact Material : A=Copper Alloy
- ⑦ Insulator Color & Color Option: L= LCP , Black
- ⑧ Packing : R=Tape & Reel
- ⑨ Other Option : 017
- ⑩ LF = For Lead Free Soldering process

CU

I/O CONNECTOR

**CU32 Series USB 2.0 Type C Receptacle SMT Type Connectors**

- ⊙ Top Mount SMT +SMT Type
- ⊙ High temperature plastic insulator
- ⊙ Contact current rating : 5 Amperes max
- ⊙ Dielectric strength:100V AC.
- ⊙ Durability cycles:10000 cycles

**NEW**

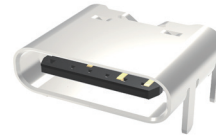

**RoHS** Compliant

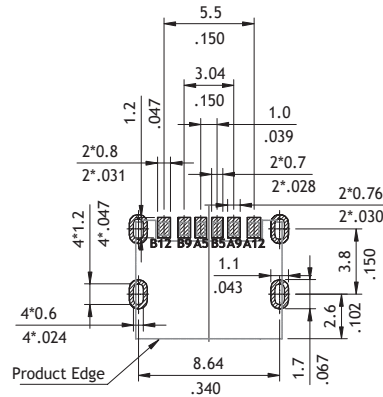
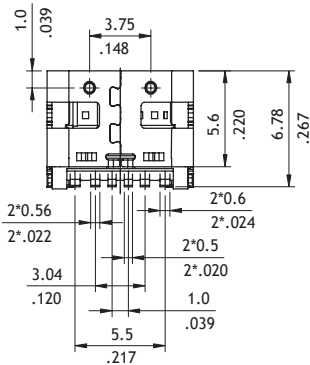
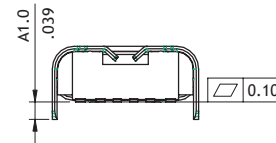
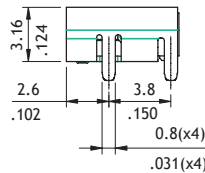
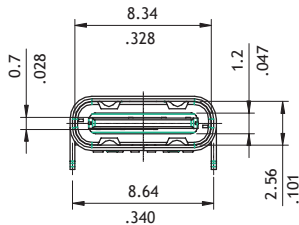
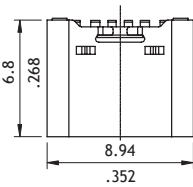

Recommended P.C.B oard Layout  
T= 1.00 mm  
Tolerance: ±0.05

**Ordering Code**

① ② ③ ④ ⑤ ⑥ ⑦ ⑧ ⑨ ⑩  
**CU32 06 S A C C L R 001 - LF**

- ① Series No.
- ② No. of Circuits
- ③ S = Socket
- ④ Plating Code :  
 A=Selective Gold Flash over Nickel  
 B=Selective 15µ" Gold flash over Nickel  
 C=Selective 30µ" Gold flash over Nickel
- ⑤ Shell Material & Plating  
 C = Stainless Steel
- ⑥ Contact Material: C=Copper Alloy
- ⑦ Insulator Material & Color Option  
 L=LCP Black
- ⑧ Packing : R= Tape & Reel
- ⑨ 001=H:1.0mm , 002=H:2.0mm
- ⑩ LF = For Lead Free Soldering process

CU

I/O CONNECTOR

**CU32 Series USB 3.1 Type C Receptacle SMT Type Connectors**

- ⊙ Top Mount Type + SMT Type
- ⊙ High temperature plastic insulator
- ⊙ Contact current rating : 5 Amperes max
- ⊙ Dielectric strength:100V AC.
- ⊙ Durability cycles:10000 cycles



RoHS Compliant

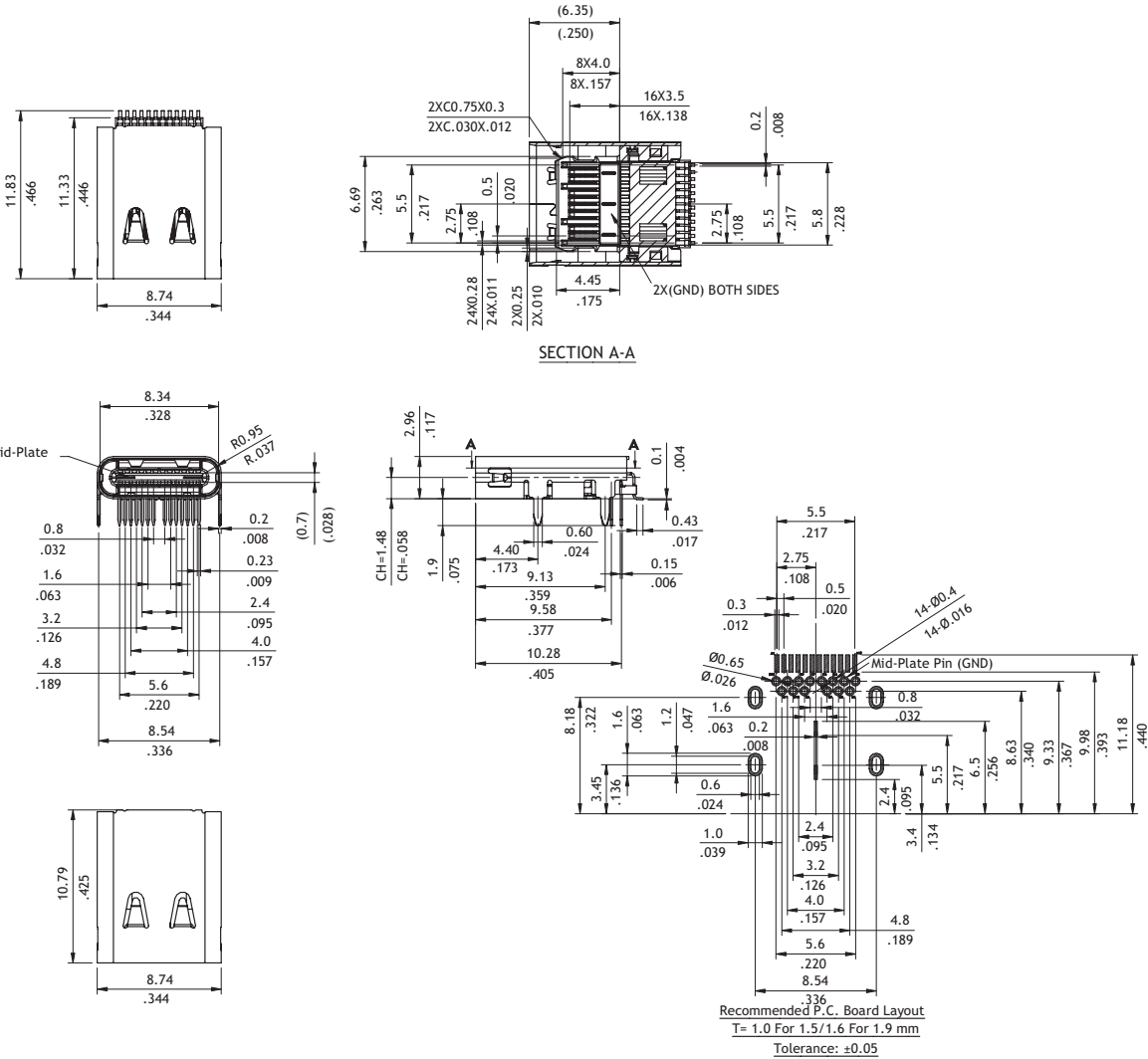
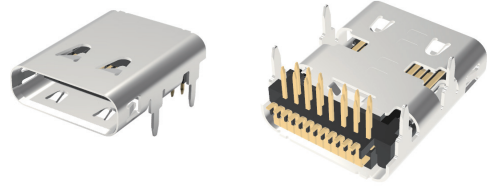

Ordering Code	①	②	③	④	⑤	⑥	⑦	⑧	⑨	⑩
	CU32	24	S	A	S	C	L	R	012	- LF

① Series No.  
 ② No. of Circuits  
 ③ S = Socket  
 ④ Plating Code :  
 A=Selective Gold Flash over Nickel  
 ⑤ Shell Material & Plating  
 S = Stainless Steel  
 ⑥ Contact Material : C= Copper Alloy  
 ⑦ Insulator Material & Color Option  
 L=LCP Black  
 ⑧ Packing : R =Tape & Reel  
 ⑨ Other Option : 012  
 ⑩ LF = For Lead Free Soldering process

CU

I/O CONNECTOR

## CU32 Series USB 2.0 Type C Receptacle SMT Type Connectors

- ⊙ Top Mount SMT Type
- ⊙ High temperature plastic insulator
- ⊙ Contact current rating : 5 Amperes max
- ⊙ Dielectric strength:100V AC.
- ⊙ Durability cycles:10000 cycles

**NEW**

RoHS Compliant

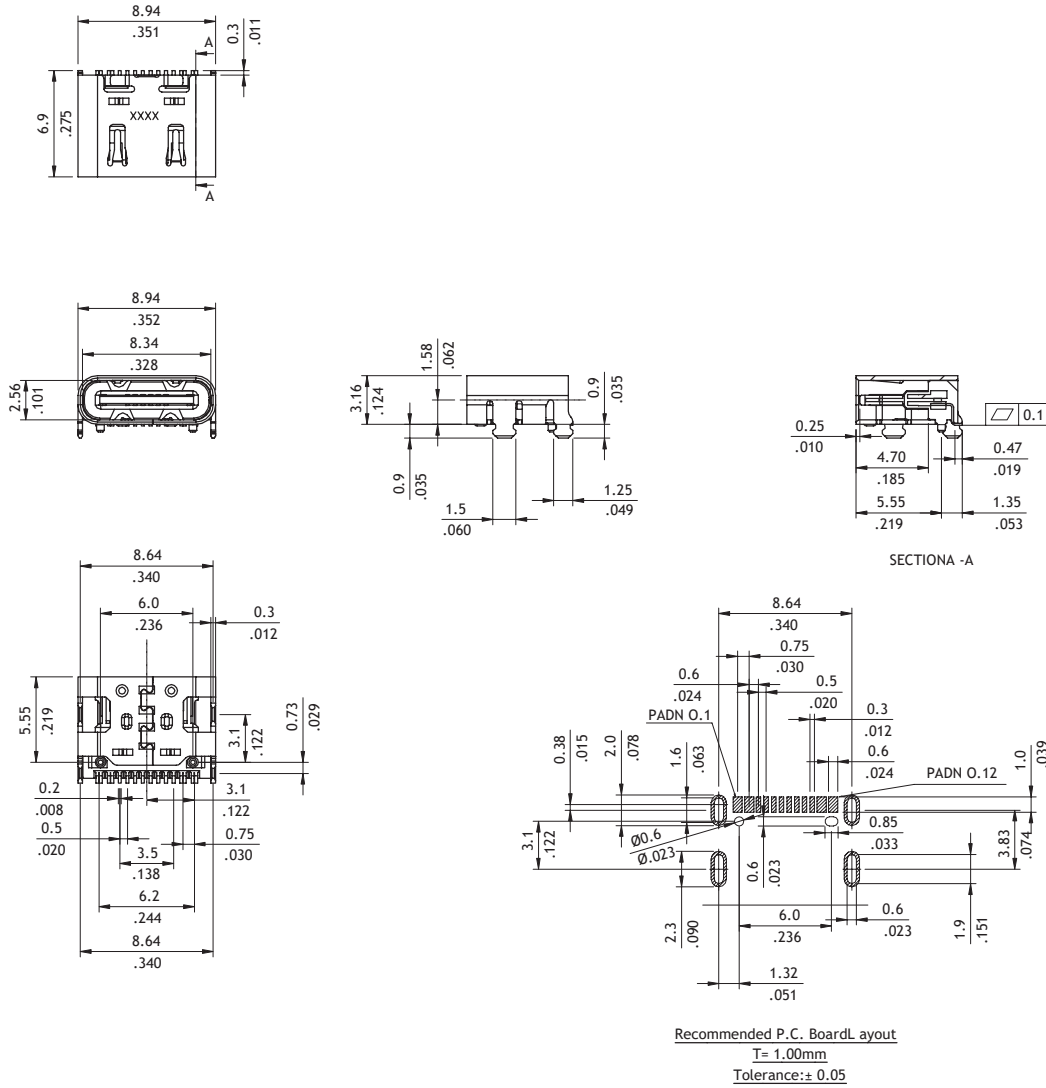

### Ordering Code

① ② ③ ④ ⑤ ⑥ ⑦ ⑧ ⑨ ⑩  
**CU32 16 S 2 S D L R 013 - NH**

- ① Series No.
- ② No. of Circuits
- ③ S = Socket
- ④ Plating Code :  
A=Selective Gold Flash over Nickel  
2=Gold Flash over Nickel
- ⑤ Shell Material & Plating  
S = Stainless steel
- ⑥ Contact Material: D=Copper Alloy
- ⑦ Insulator Material & Color Option  
L=LCP Black
- ⑧ Packing : R= Tape & Reel
- ⑨ Other Option : 013
- ⑩ NH = For Lead Free soldering process and Halogen-Free

CU

I/O CONNECTOR

**CU32 Series USB 2.0 Type C Receptacle DIP Type Connectors**

- ⊙ Top Mount DIP Type
- ⊙ High temperature plastic insulator
- ⊙ Contact current rating : 5 Amperes max
- ⊙ Dielectric strength:100V AC.
- ⊙ Durability cycles:10000 cycles

**NEW**

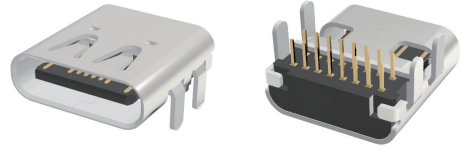

RoHS Compliant

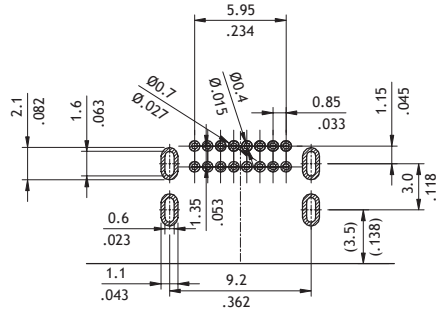
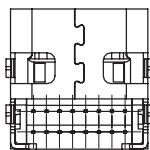
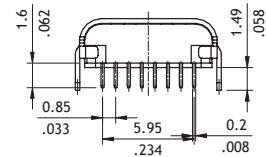
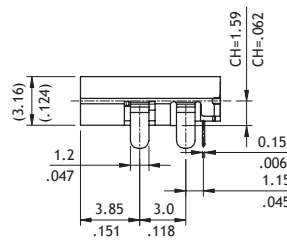
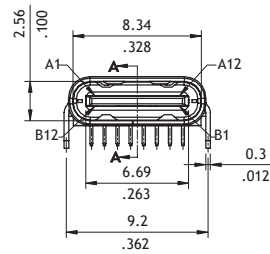
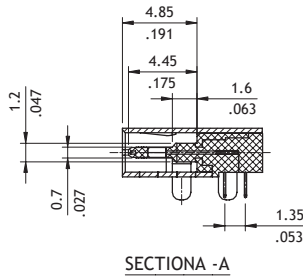
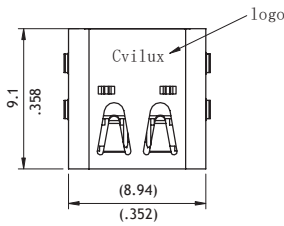

Recommended P.C.B board Layout  
T= 1.00 mm  
Tolerance: ± 0.05

**Ordering Code**

① ② ③ ④ ⑤ ⑥ ⑦ ⑧ ⑨ ⑩  
**CU32 16 S A S B L R 004 - NH**

- ① Series No.
- ② No. of Circuits
- ③ S = Socket
- ④ Plating Code :  
 A=Selective Gold Flash over Nickel  
 B=Selective 15µ" Gold flash over Nickel  
 C=Selective 30µ" Gold flash over Nickel  
 2=Gold Flash over Nickel
- ⑤ Shell Material & Plating : S = Stainless Steel
- ⑥ Contact Material : B= Copper Alloy
- ⑦ Insulator Material & Color Option  
 L=LCP Black
- ⑧ Packing : R =Tape & Reel
- ⑨ 004= With Logo 006= Without Logo
- ⑩ NH = For Lead Free soldering process and Halogen-Free

CU

I/O CONNECTOR

## CU32 Series USB 2.0 Type C Receptacle SMT Type Connectors

- ⊙ Top Mount SMT Type
- ⊙ High temperature plastic insulator
- ⊙ Contact current rating : 3 Amperes max
- ⊙ Dielectric strength:100V AC.
- ⊙ Durability cycles:10000 cycles

**NEW**

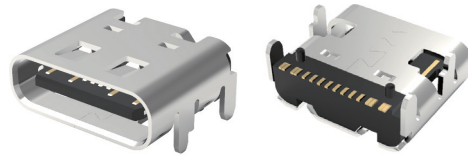

RoHS Compliant

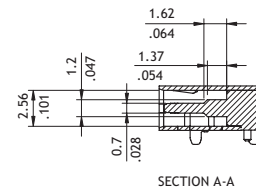
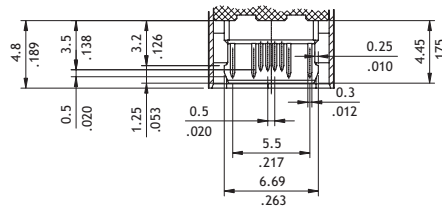
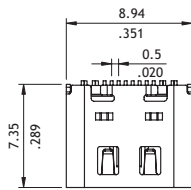

SECTION B-B

SECTION A-A

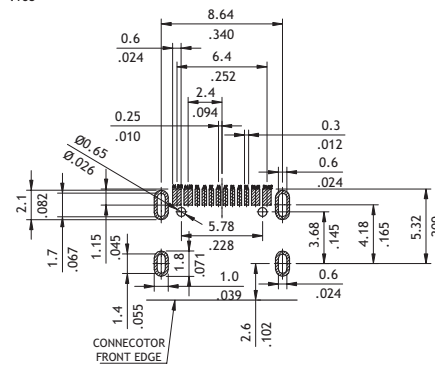
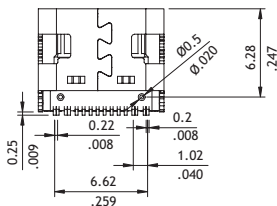
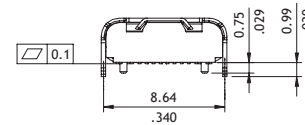
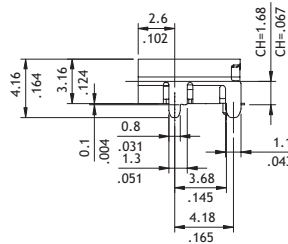
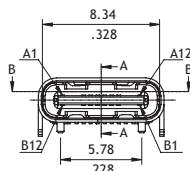

Recommended P.C. Board Layout  
T=1.00 mm  
Tolerance: ±0.05

### Ordering Code

① ② ③ ④ ⑤ ⑥ ⑦ ⑧ ⑨ ⑩  
**CU32 16 S A S D L R 009 - NH**

- ① Series No.
- ② No. of Circuits
- ③ S = Socket
- ④ Plating Code :  
A= Selective Gold Flash over Nickel  
2= Gold Flash over Nickel
- ⑤ Shell Material & Plating :  
S = Stainless steel
- ⑥ Contact Material : D= Copper Alloy
- ⑦ Insulator Material & Color Option : L=LCP Black
- ⑧ Packing : R =Tape & Reel
- ⑨ 009= With Spring 010= Without Spring
- ⑩ NH = For Lead Free soldering process and Halogen-Free

**CU32 Series USB 3.1 Type C Receptacle Type Connectors**

- ⊙ Clamp Plate Type
- ⊙ High temperature plastic insulator
- ⊙ Contact current rating : 5 Amperes max
- ⊙ Dielectric strength:100V AC.
- ⊙ Durability cycles:10000 cycles.

**NEW**



RoHS Compliant

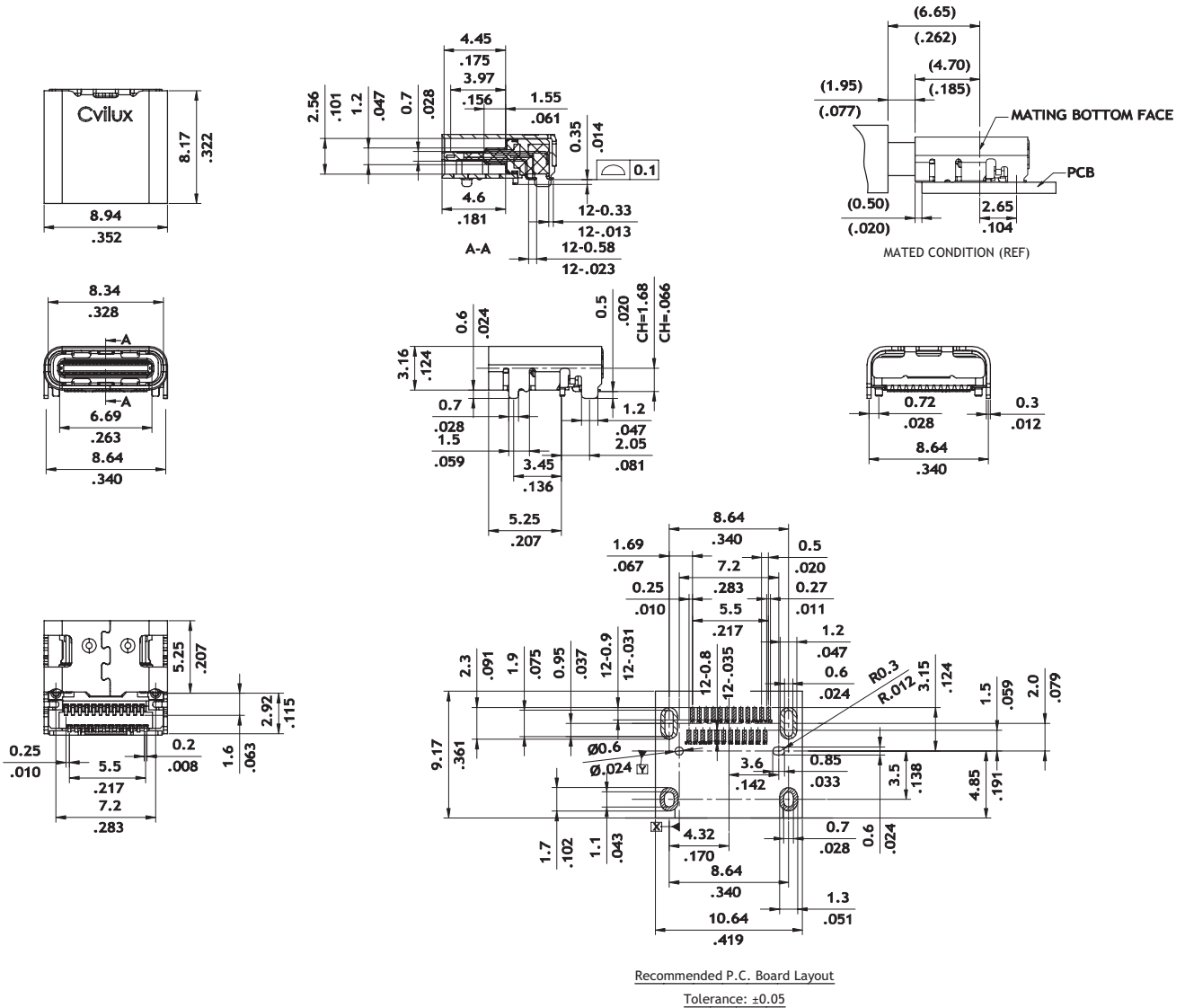

**Ordering Code**

① ② ③ ④ ⑤ ⑥ ⑦ ⑧ ⑨ ⑩  
**CU32 24 S A S B L R 022 - NH - 1**

- ① Series No.
- ② No. of Circuits:24
- ③ S = Socket
- ④ Plating Code :  
 A=Selective Gold Flash over Nickel  
 J= Selective 3μ" Gold flash over Nickel
- ⑤ Shell Material & Plating  
 S=Stainless Steel Nickel Plating
- ⑥ Contact Material: B = Cooper Alloy
- ⑦ Insulator Material &Color option  
 L= LCP , Black
- ⑧ Packing : A = Tape & Reel
- ⑨ Other Oprion : 022
- ⑩ NH = For Lead Free soldering process and Halogen-Free  
 \*Special options consult manufacturer

CU

I/O CONNECTOR

**CU33 Series USB 2.0 Type C Receptacle Vertical Type Connectors**

- ⊙ Vertical DIP Type
- ⊙ High temperature plastic insulator
- ⊙ Contact current rating : 5 Amperes max
- ⊙ Dielectric strength:100V AC.
- ⊙ Durability cycles:10000 cycles

**NEW**

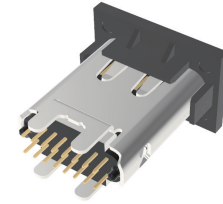

RoHS Compliant  

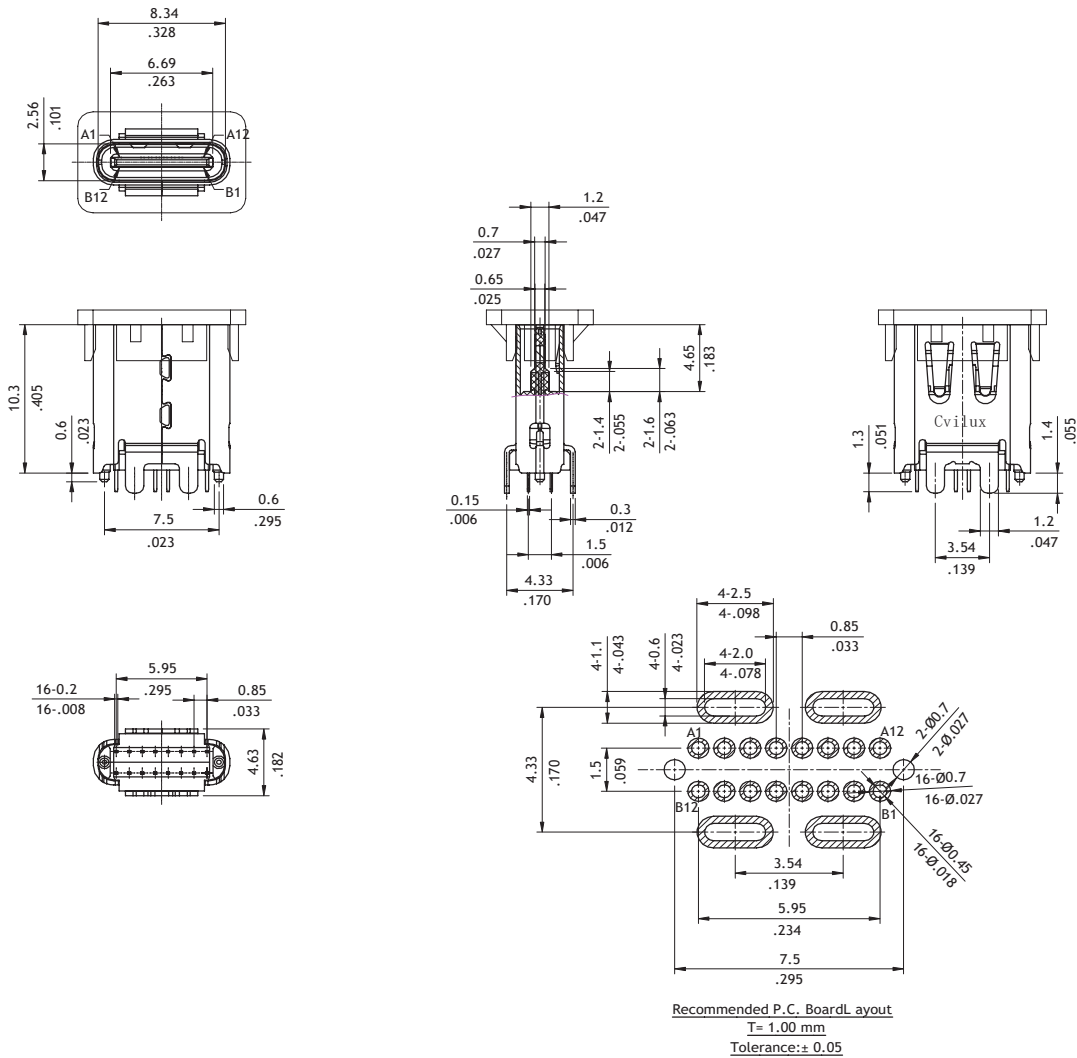

**Ordering Code**

① ② ③ ④ ⑤ ⑥ ⑦ ⑧ ⑨ ⑩  
**CU33 16 S 2 S B L R 003 - NH**

- ① Series No.
- ② No. of Circuits
- ③ S = Socket
- ④ Plating Code :  
 2= Gold Flash over Nickel  
 3=Selective 15µ" Gold flash over Nickel  
 4=Selective 30µ" Gold flash over Nickel
- ⑤ Shell Material & Plating :  
 S = Stainless Steel
- ⑥ Contact Material : B= Copper Alloy
- ⑦ Insulator Material & Color Option  
 L=LCP Black
- ⑧ Packing : R =Tape & Reel
- ⑨ Other Option : 003
- ⑩ NH = For Lead Free soldering process and Halogen-Free

CU

I/O CONNECTOR

**CU33 Series USB 3.1 Type C Plug SMT Type Connectors**

- ⊙ Vertical SMT Type
- ⊙ High temperature plastic insulator
- ⊙ Contact current rating : 3 Amperes max
- ⊙ Dielectric strength:100V AC.
- ⊙ Durability cycles:10000 cycles

**NEW**

RoHS Compliant 

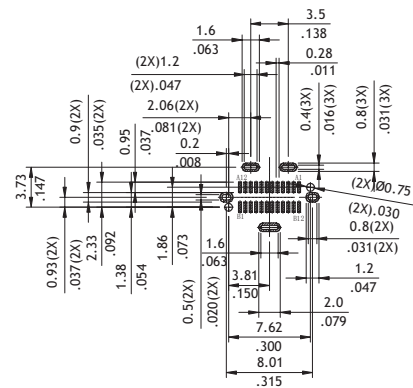
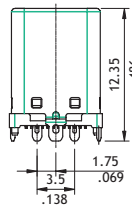
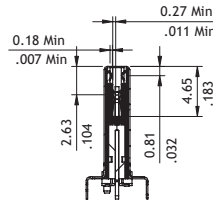
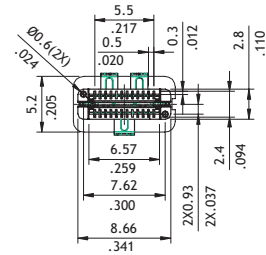
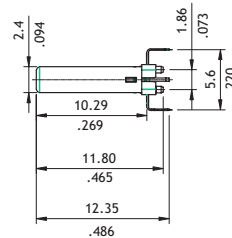
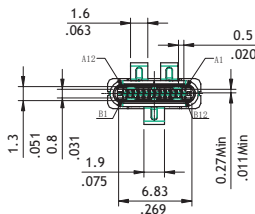
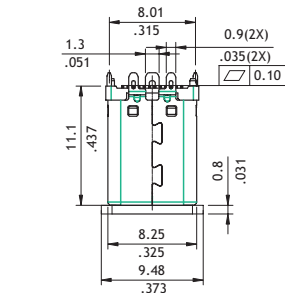
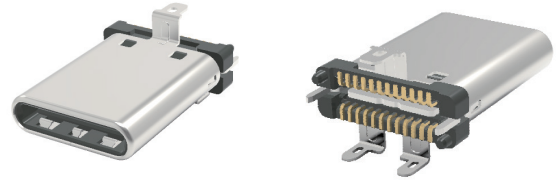

Recommended P.C. Board Layout  
T= 0.80mm  
Tolerance: ±0.05

**Ordering Code**

① ② ③ ④ ⑤ ⑥ ⑦ ⑧ ⑨ ⑩  
**CU33 24 P A S D L R 001 - LF**

- ① Series No.
- ② No. of Circuits
- ③ P = Plug
- ④ Plating Code :  
A=Selective Gold Flash over Nickel
- ⑤ Shell Material & Plating  
S = Stainless Steel
- ⑥ Contact Material : D =Copper Alloy
- ⑦ Insulator Mateial & Color : L= LCP , Black
- ⑧ Packing : R = Tape & Reel
- ⑨ 001= Straddle Forming type
- ⑩ LF = For Lead Free Soldering process

CU

I/O CONNECTOR



**CU35 Series USB 2.0 Type C Receptacle Connectors**

- ⊙ Side Plug DIP Type
- ⊙ High temperature plastic insulator
- ⊙ Contact current rating : 5 Amperes max
- ⊙ Dielectric strength:100V AC.
- ⊙ Durability cycles:10000 cycles

**NEW**



RoHS Compliant

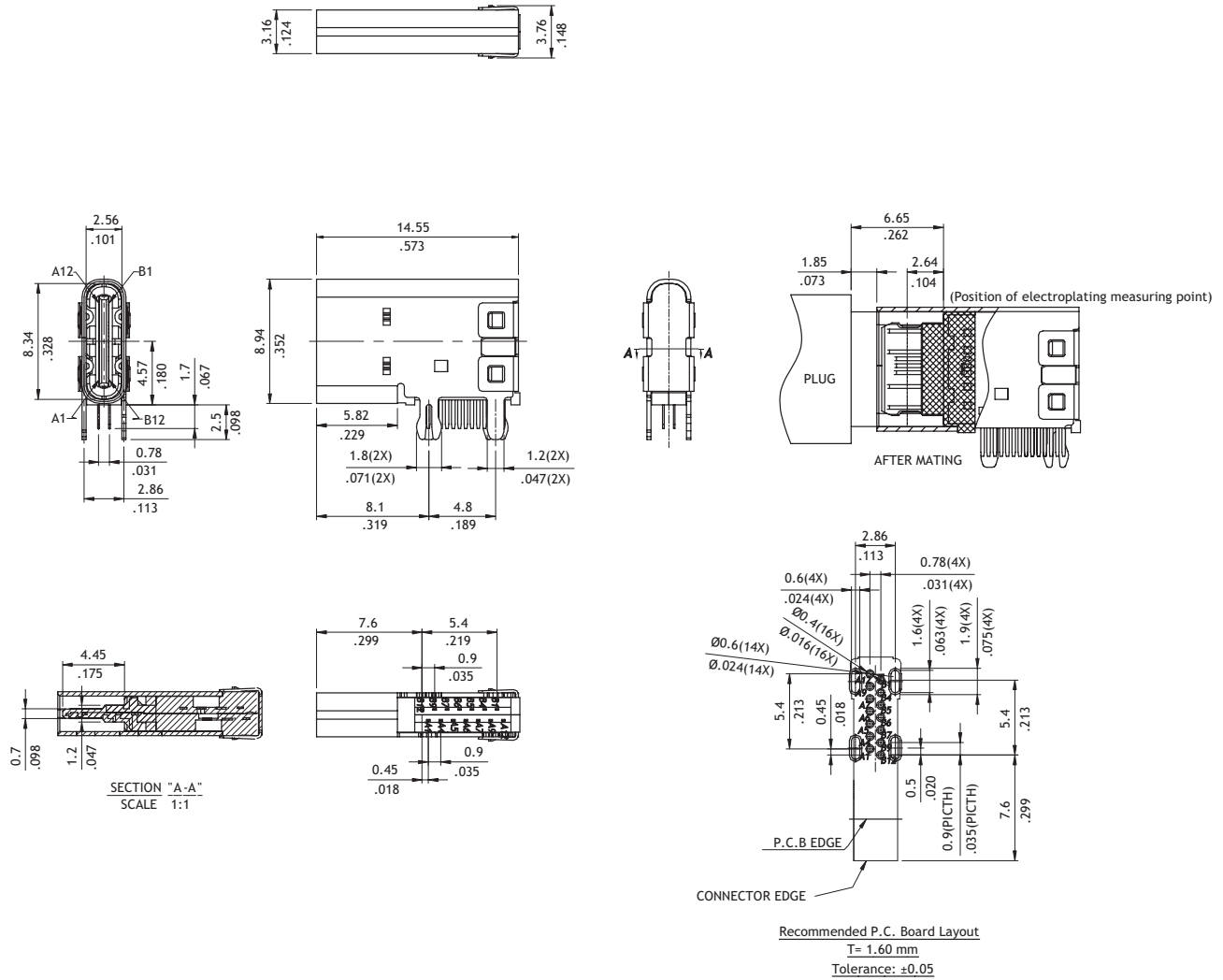

<b>Ordering Code</b>	①	②	③	④	⑤	⑥	⑦	⑧	⑨	⑩
	<b>CU35</b>	<b>14</b>	<b>S</b>	<b>2</b>	<b>S</b>	<b>A</b>	<b>L</b>	<b>A</b>	<b>001</b>	<b>-NH</b>

① Series No.	⑥ Contact Material : A= Copper Alloy
② No. of Circuits	⑦ Insulator Material & Color Option
③ S = Socket	L=LCP Black
④ Plating Code :	⑧ Packing : A = Tray
A= Selective Gold Flash over Nickel	⑨ Other Option : 001
2= Gold Flash over Nickel	⑩ NH = For Lead Free soldering process and Halogen-Free
⑤ Shell Material & Plating : S = Stainless Steel	

CU

I/O CONNECTOR

## CU39 Series USB 3.1 Type C Receptacle Connectors

- ⊙ Middle Mount DIP + SMT Type
- ⊙ IP 67 waterproof
- ⊙ High temperature plastic insulator
- ⊙ Contact current rating : 5 Amperes max
- ⊙ Dielectric strength:100V AC.
- ⊙ Durability cycles:10000 cycles

**NEW**

RoHS Compliant

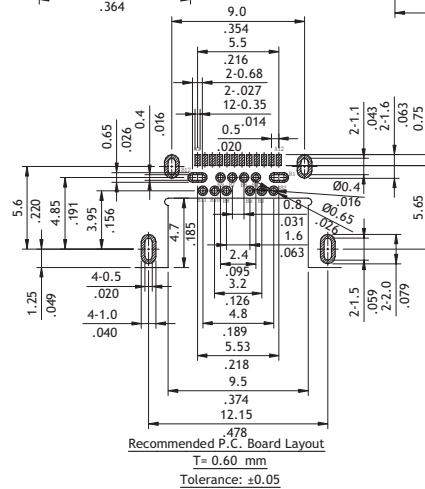
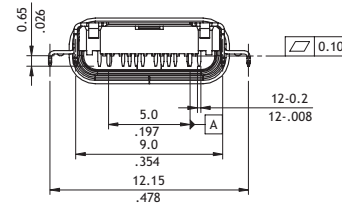
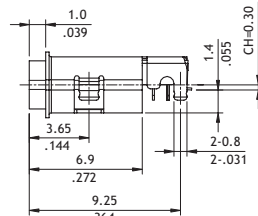
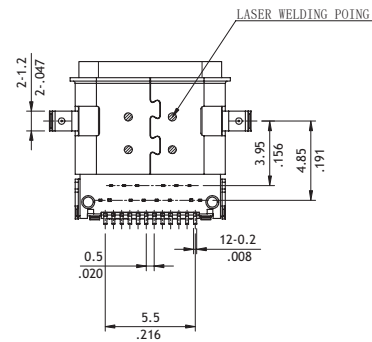
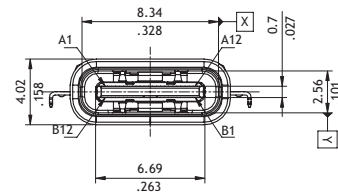
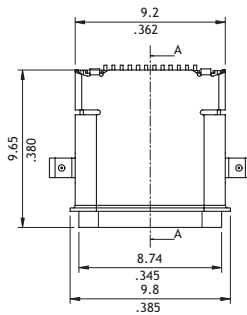
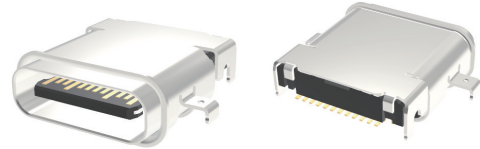

### Ordering Code

① ② ③ ④ ⑤ ⑥ ⑦ ⑧ ⑨ ⑩  
**CU39 24 S F S F D R 003 - LF**

- ① Series No.
- ② No. of Circuits
- ③ S = Socket
- ④ Plating Code :  
F = Selective Gold flash over Nickel
- ⑤ Shell Material & Plating :  
S = Stainless steel

- ⑥ Contact Material : F= Copper Alloy
- ⑦ Insulator Material & Color Option: D= High temperature Black
- ⑧ Packing : R =Tape & Reel
- ⑨ 003= Waterproof Type (IP67)
- ⑩ LF = For Lead Free Soldering process

CU

I/O CONNECTOR

CRA Series RF Micro Coaxial Connectors

RoHS Compliant

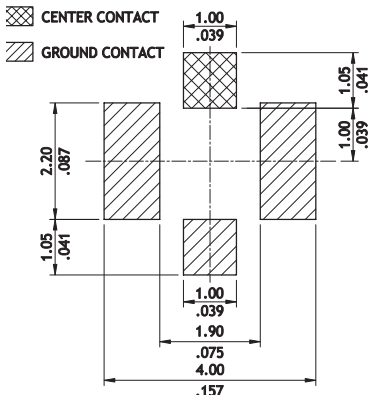
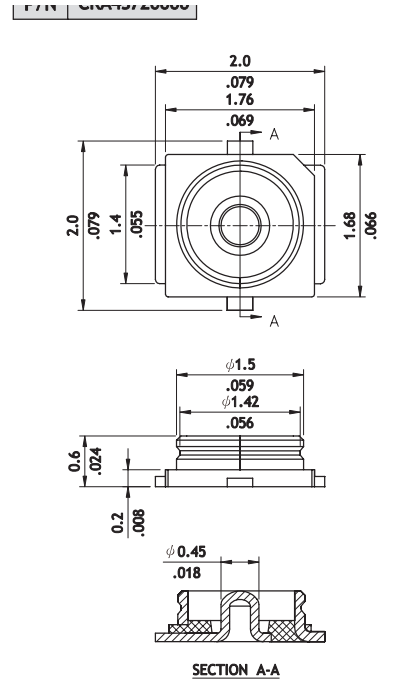
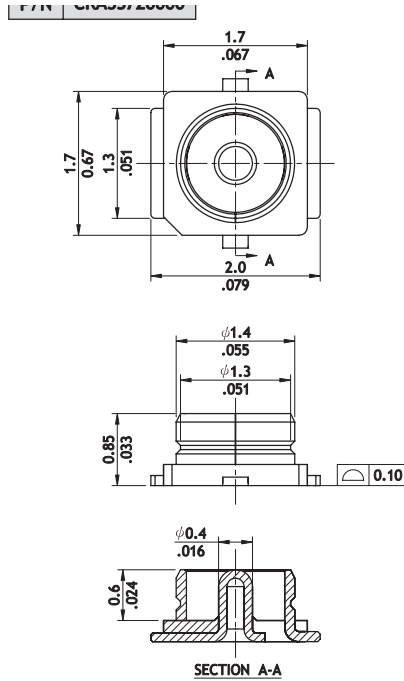
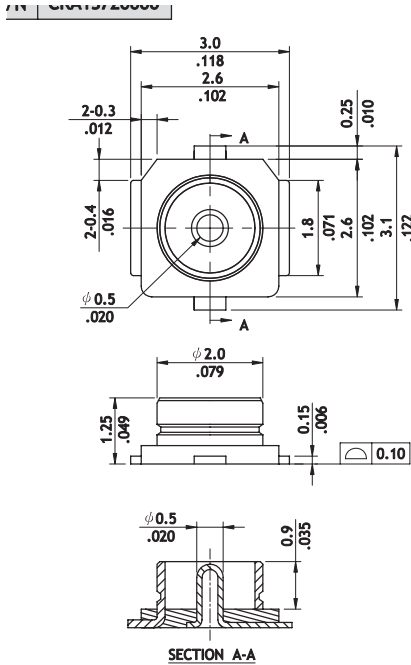

Recommended P.C. Board Layout (TOLERANCE: ±0.05)

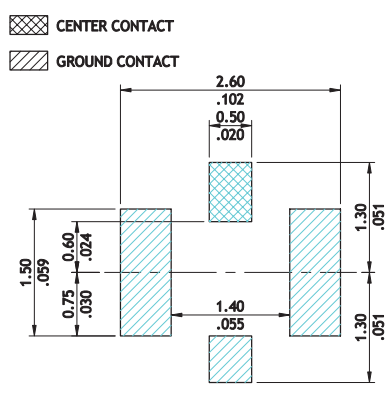

Recommended P.C. Board Layout

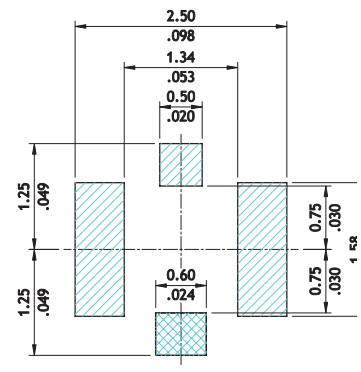

Recommended P.C. Board Layout

Ordering Code

① ② ③ ④ ⑤  
**CRA1 S 7 2 0000**

- ① Series No. CRA1, CRA3, CRA4
- ② S=Receptacle Connector
- ③ Center Contact Plating: 7 = 3μ"Gold flash over Nickel

- ④ Ground Contact Plating: 2=Gold flash over Nickel
- ⑤ Other Options: 0000=standard

# CRA Series RF Micro Coaxial Cable

P/N CRA1W\*A\*\*\*1

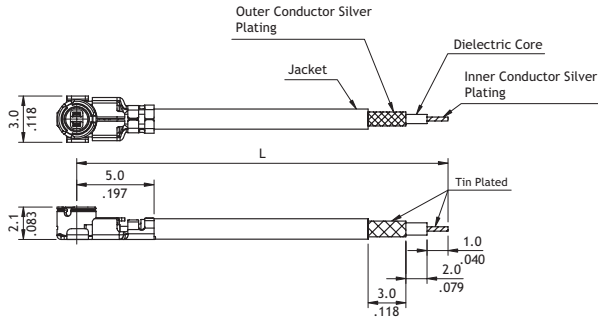

Series	PLUG	Cable Type	Receptacle	Mating Height
CRA1	CRA1W3A***1	1.13	CRA1S72000	2.5mm(Max.)
	CRA1W2A***1	1.32		
	CRA1W4A***1	1.37		
CRA2	CRA2W1A***1	0.81		2.0mm(Max.)
	CRA2W3A***1	1.13		
	CRA2W2A***1	1.32		
CRA2W4A***1	1.37			
CRA3	CRA3W1A***1	0.81	CRA3S72000	1.5mm(Max.)
CRA4	CRA4W1A***1	0.81	CRA4S72000	1.2mm(Max.)
	CRA4W3A***1	1.13		

\*Note : Single and dual ends can be offered

P/N CRA2W\*A\*\*\*1

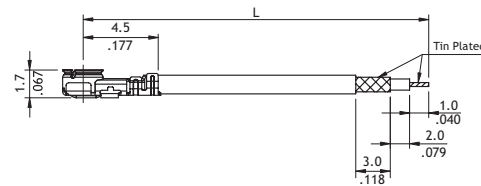
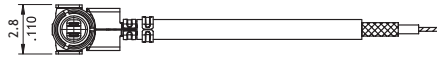

P/N CRA3W1A\*\*\*1

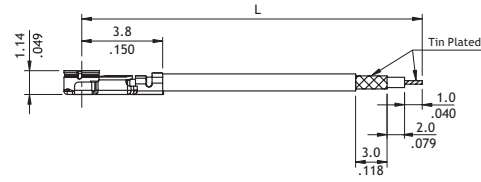
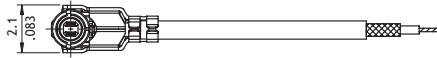

P/N CRA4W3A\*\*\*1

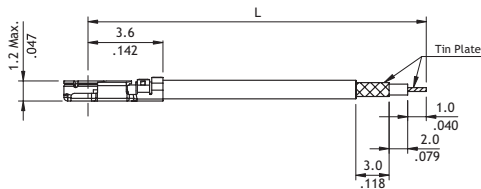
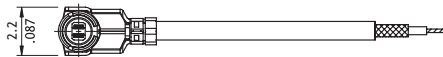

## Ordering Code

① CRA ② W ③ 1 ④ A ⑤ 100 ⑥ 1

- ① Series No.  
CRA1,CRA2,CRA3,CRA4
- ② W=Wire Assembly
- ③ Application Cable:  
1 =OD 0.81mm 2=OD 1.32mm  
3=OD 1.13mm 4=OD 1.37mm

- ④ A= Both ends crimped cable(Gold Plated)  
B=One end crimped cable,the other end stripped(Gold Plated)
- ⑤ Length:  
example:L= 100 = 100mm
- ⑥ Cable Color:1=Black(standard)



## Marketing Site

CviLux Corporation  
 CviLux USA Corporation  
 CviLux KOREA Corporation  
 CviLux Technology  
 (Shenzhen) Corporation  
 CviLux SDN BHD  
 CviLux JAPAN Office  
 CviLux XIAMEN Office  
 CviLux BRAZIL Office  
 CviLux GERMANY Office  
 CviLux VIETNAM Office  
 Allsor Electronics Co., Ltd.  
 Allsor Technology Corporation  
 CviCloud Corporation

## Factory Site

**Tamshui-Taiwan**  
 CviLux Corporation  
**Dongguan-China**  
 CviLux Electronics (Dongguan) Co., Ltd  
 Dongguan Qunhan Electronics Co., Ltd  
**Suzhou-China**  
 CviLux Technology (Suzhou) Co., Ltd  
**Chongqing-China**  
 CviLux Technology (Chongqing) Co., Ltd  
**Anhui -China**  
 Anhui CviLux Technology CO., Ltd.  
**Lao**  
 CviLux Lao Co., Ltd.  
**Vietnam**  
 CviLux Vietnam Corporation



Taiwan

South China  
(1)

South China  
(2)

East China

West China

Central China

Lao

Vietnam

