

A = 1.5 \* No.of Spaces  
 B = A + 4.5  
 C = A + 2.1  
 \* Available in 2 through 15 circuits

		TOLERANCE		
Dim	Circuits	2~6P	7~10P	11~15P
A		±0.10	±0.15	±0.20

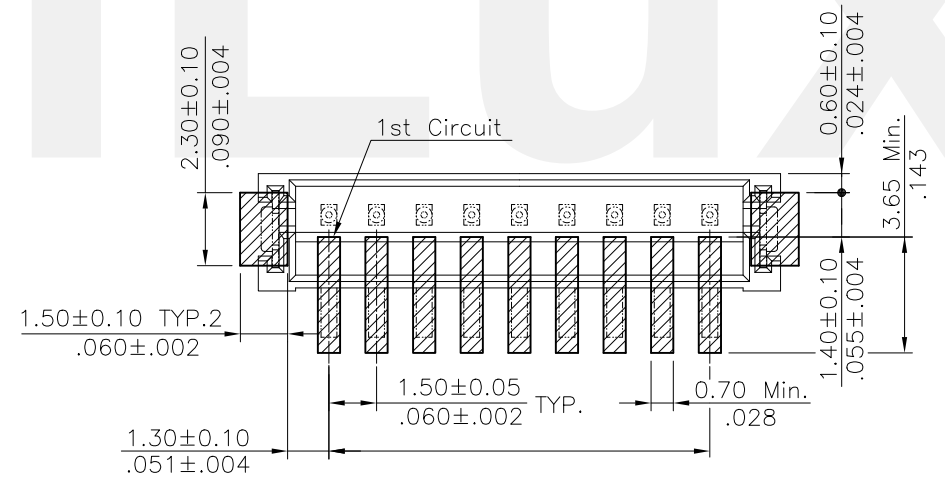

Sold Pad Pattern

Material:

- \* Insulation: Nylon 9T+33% G.F. UL 94V-0, Color Nature
- \* Contact: Brass with Matte Tin plated
- \* TAB: Brass with Matte Tin plated

Ordering Code:

CI15 \*\* M 1 V \* 0 - LF  
 ① ② ③ ④ ⑤ ⑥ ⑦ ⑧

- ① Series No.
- ② No. of Circuits:
- ③ Contacts Type: M=SMT
- ④ Plating: 1= 3.05µm(120µ") Min. Matte Tin over 1.27µm(50µ") Nickel
- ⑤ V = Straight Type
- ⑥ Packing option: R=Tape & Reel with pad  
T=Tube Packing without pad
- ⑦ Option: 0 = Standard
- ⑧ -LF= For Leadfree IR Processes

Lead Free Process

RoHS Compliant

④	Enya	9/11-13'	ECNT113054/ECRH113002		DATE	UNIT: mm / inch	TITLE: 1.50MM(.059") Sraight SMT Type Header	瀚荃股份有限公司 CviLux Corporation
③	Sun	9/22-11'	ECR11039-2/ECN11060	DRAWN BY: Enya	9/11-13'	TOLERANCE UNLESS OTHERWISE SPECIFIED	MATERIAL:	
②	Sandy	11/29-07'	ECN07498	ENGINEER: Easley	9/12-13'	.X ± 0.30/.012 X: ± 1'	FINISH:	DRAWING NO. CI1508SE
①	Sandy	04/29-07'	ECN07153	CHECKED BY: Easley	9/12-13'	.XX ± 0.20/.008 X: ±		PART NO. CI15**M1V*0-LF
SYM	NAME	DATE	REVISIONS	APPROVED BY: David	9/12-13'	.XXX ± 0.10/.004 XX: ±	SCALE 4 / 1	SHEET 1 OF 2

**CVILUX CORP**  
 2013.10.04  
 ISSUED

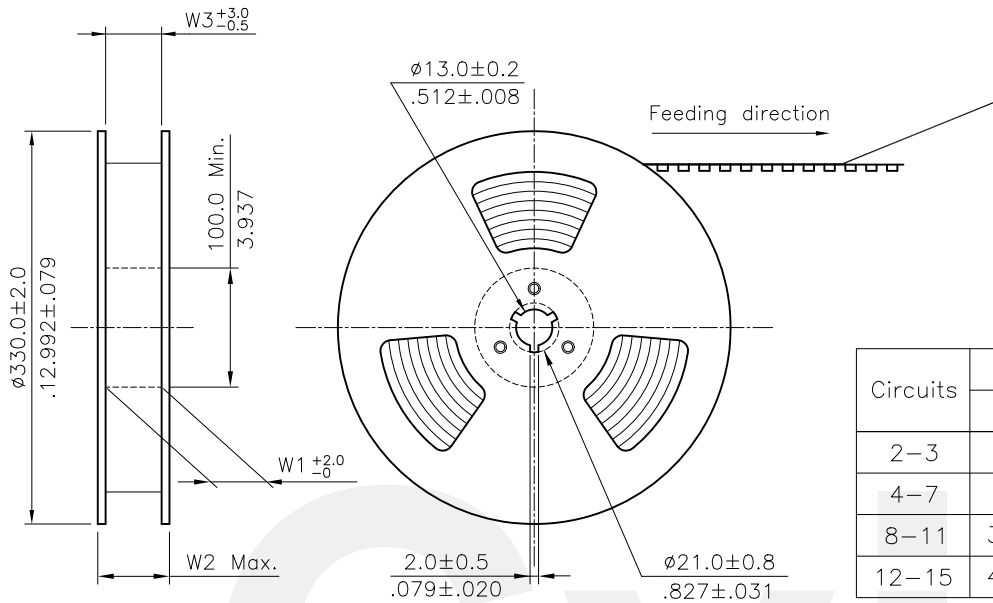

NOTE :

- ⚠ \* Reel Material : Corrugated Paper
- \* Carrier Material : Clear, Conductive Polystyrene Alloy
- \* Cover Tape Material : Polyester
- \* Cover Tape Peel Strength : 0.1N – 1.3N
- \* Carrier camber is within 1mm in 100mm
- \* All dimensions meet EIA-481-2 & EIA-481-3 requirements.
- ⚠ \* Quantity : 900 PCS/Reel

Circuits	Dimension					Packing (Reel/Carton)
	E	F	W1	W2	W3	
2-3	16.0(.630)	-----	16.5(.650)	22.5(.886)	16.5(.650)	11
4-7	24.0(.945)	-----	24.5(.965)	30.5(1.201)	24.5(.965)	9
8-11	32.0(1.260)	28.4(1.118)	32.5(1.280)	38.5(1.516)	32.5(1.280)	7
12-15	44.0(1.732)	40.4(1.596)	44.5(1.752)	50.5(1.988)	44.5(1.752)	5

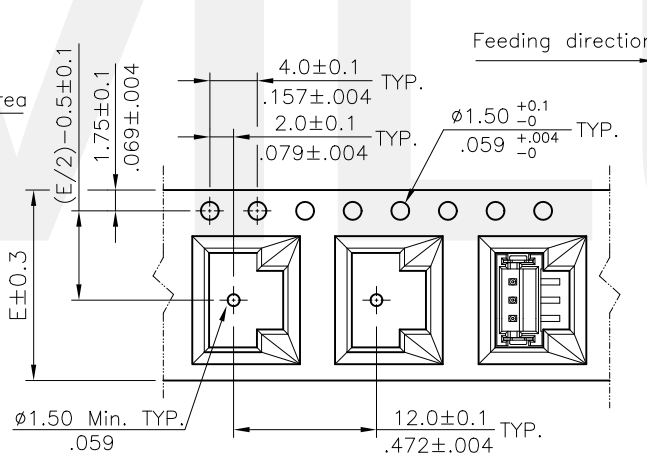
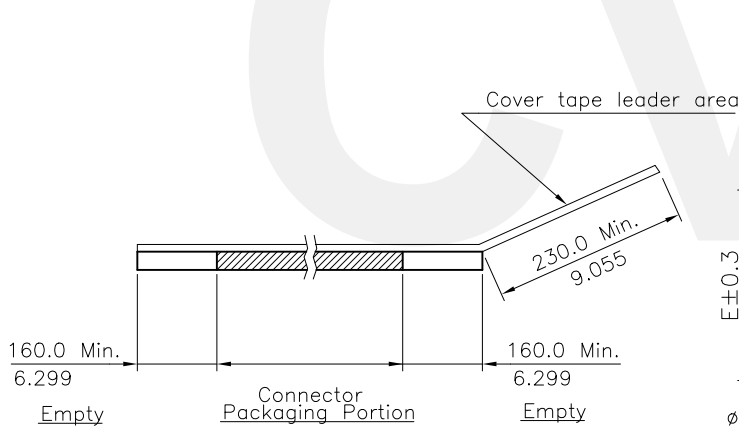

WIDTH : 16.24 mm Carrier

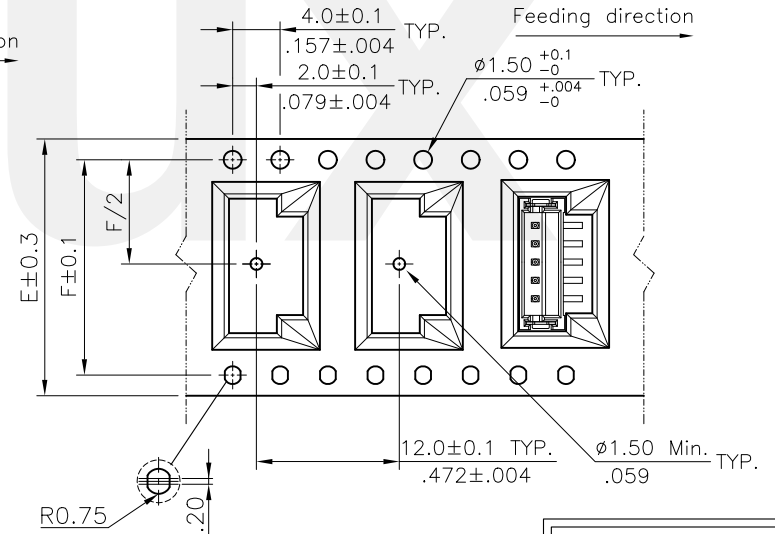

WIDTH : 32.44 mm Carrier

RoHS Compliant

SYM	NAME	DATE	REVISIONS	APPROVED BY:	DATE	UNIT: mm / inch	TITLE:	MATERIAL:	FINISH:	DRAWING NO.	PART NO.	SHEET	OF	SCALE		
4	Enya	9/11-13'	ECNT113054/ECRH113002				1.50MM(.059") Siraight SMT Type Header									
3	Sun	9/22-11'	ECR11039-2/ECN11060	DRAWN BY:	Enya	9/11-13'	TOLERANCE UNLESS OTHERWISE SPECIFIED									
2	Sandy	11/29-07'	ECN07498	ENGINEER:	Eisley	9/12-13'									.X ±	.X' ± 1'
1	Sandy	04/29-07'	ECN07153	CHECKED BY:	Eisley	9/12-13'									.XX ±	.X ±
				APPROVED BY:	David	9/12-13'									.XXX ±	.XX ±
												CI1508SE		CI15**M1V*0-LF		
														2 OF 2		