

NOTE:

- Material:  
Base: Nylon 6T + 30% G.F UL 94V-0  
Color Nature  
Contact: Phosphor Bronze  
Tab: Brass, with Matte Tin plated
- For Lead Free IR Reflow Process

ORDERING CODE

CI11 \*\* M \* H \*0 -NH  
① ② ③ ④ ⑤ ⑥ ⑦

- Series No.
- Contacts:
- M= SMT type header
- Plating:  
1= Matte Tin Plating over Nickel  
2= Gold Flash Plating over Nickel
- Type: H= Right angle
- Option: R0= Tape & reel packing (Without pick & place pad) (Standard)  
T0= Tube packing (Without pick & place pad)
- Other option:  
-NH= For Lead Free IR Processes and Halogen-Free

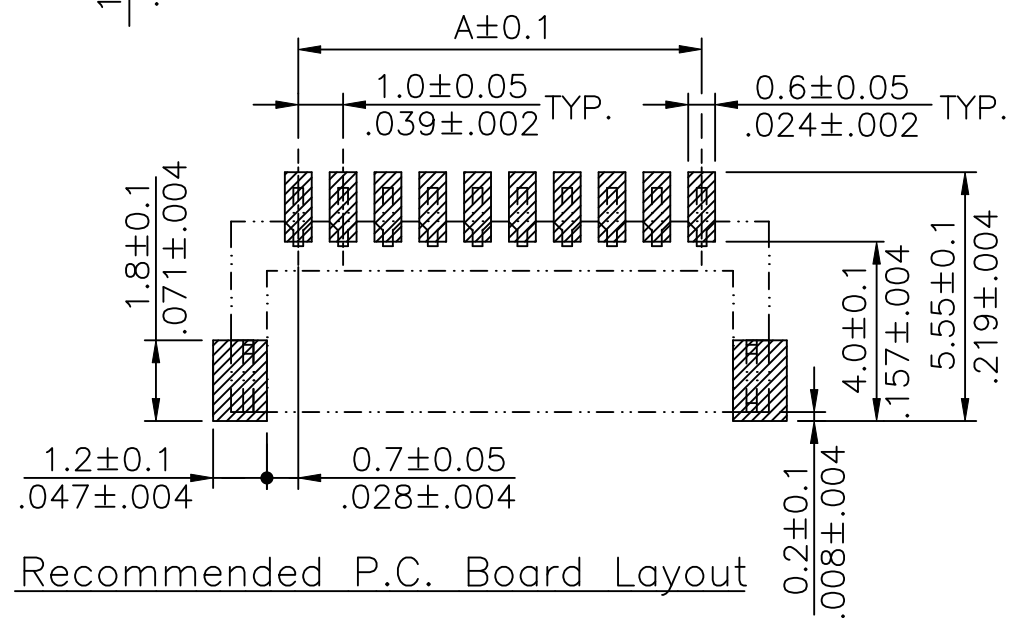
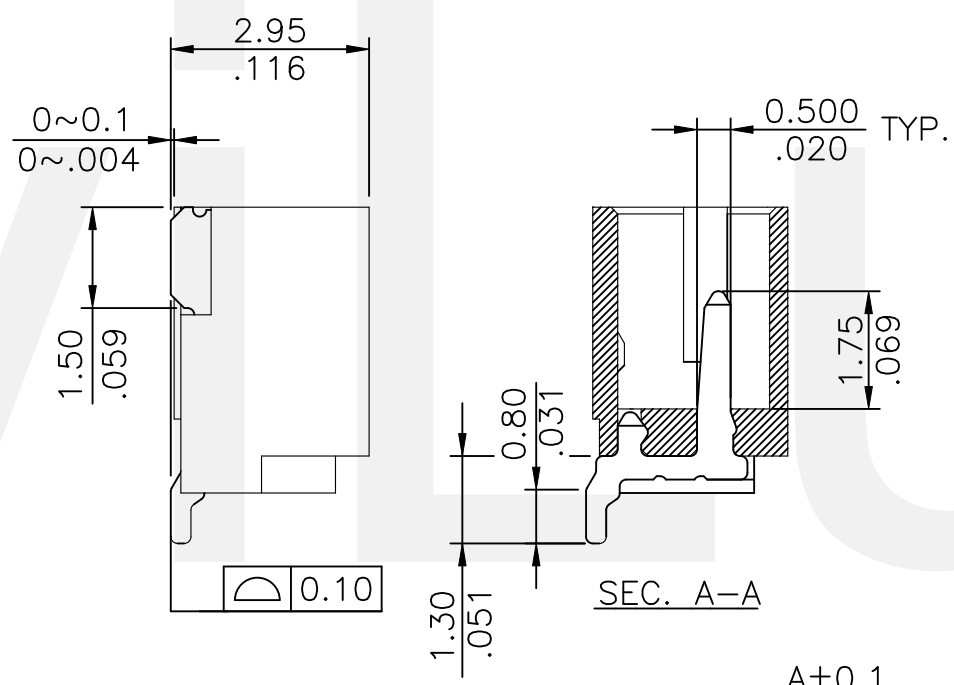

DIM. A = 1.00 x NO. OF SPACES  
DIM. B = DIM. A + 3.0

△ \* AVAILABLE IN 2 THROUGH 18,20,24 AND 26 CIRCUITS

Lead Free Process  
Halogen-Free  
RoHS Compliant

△7	Amy	11/22-23	ECNT123179/ECRB123029		DATE	UNIT: mm / inch	TITLE: 1.00MM(.079") WIRE TO BOARD CONNECTOR	 瀚荃股份有限公司 CviLux Corporation
△6	Sun	11/27-19	ECNT119339	DRAWN BY: Amy	11/22-23'	TOLERANCE UNLESS OTHERWISE SPECIFIED	MATERIAL:	
△6	Ellie	12/19-14	ECNT114252/ECRT114090	ENGINEER: Sun	11/22-23'	.X ± 0.30/.012 X' ± 1"	FINISH:	
△5	Sun	1/28-14'	ECNT114016	CHECKED BY: Eisley	11/22-23'	.XX ± 0.20/.008 .X' ±	DRAWING NO. CI1131SI PART NO. CI11**M*H*0-NH	
SYM	NAME	DATE	REVISIONS	APPROVED BY: Eisley	11/22-23'	.XXX ± 0.10/.004 .XX' ±	SCALE 6 / 1 SHEET 1 OF 2	

**CviLux Corp**  
2023/11/27  
ISSUED

NOTE :

- ⚠️⚠️ \* Reel Material : HIPS
- \* Carrier Material : Clear, Conductive Polystyrene Alloy
- \* Cover Tape Material : Polyester
- \* Cover Tape Peel Strength : 0.1N – 1.3N
- \* Carrier camber is within 1mm in 100mm
- ⚠️ \* All dimensions meet EIA-481 requirements.
- \* Quantity : 1500 PCS/Reel

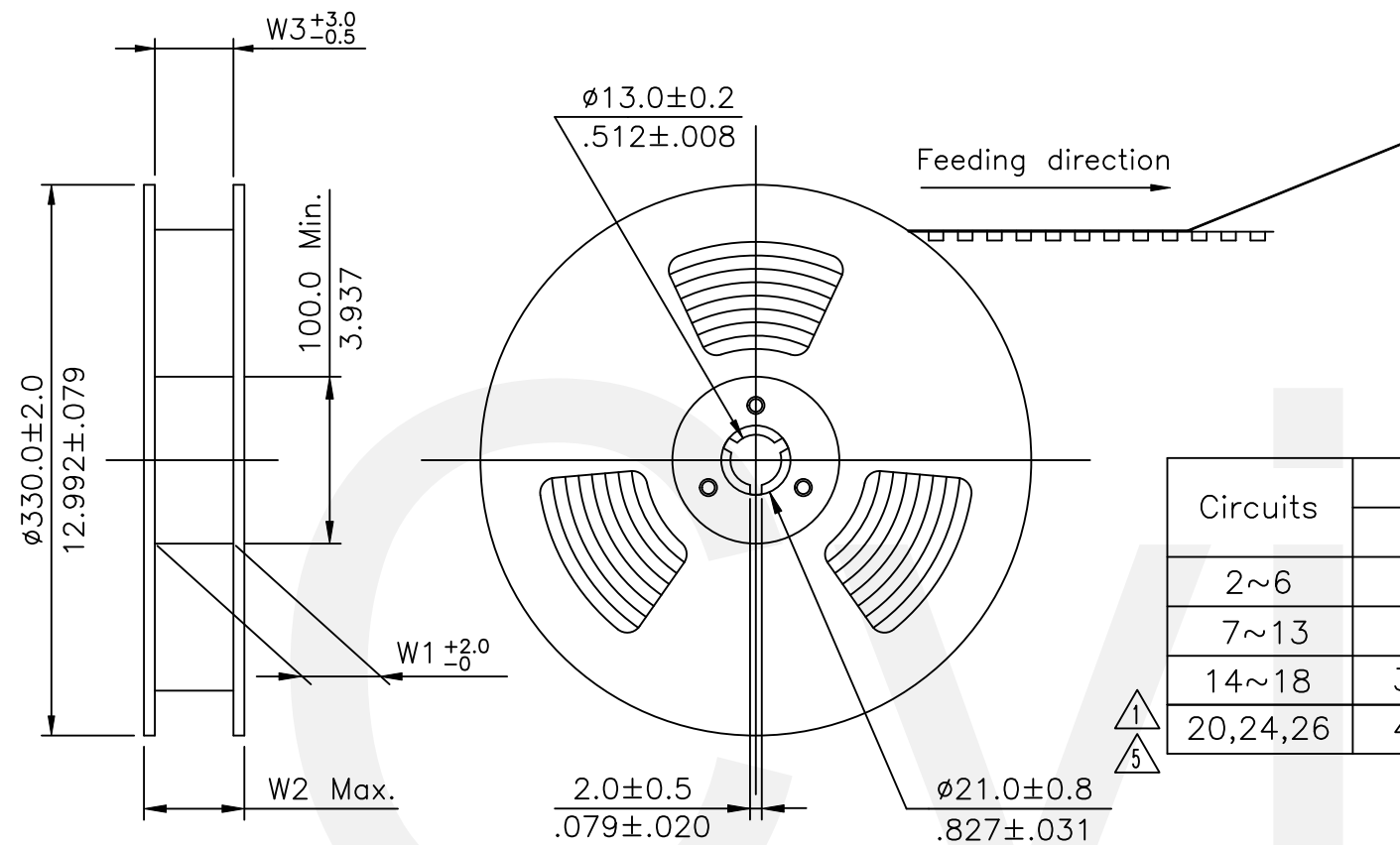

Circuits	Dimension					Packing (Reel/Carton)
	E	F	W1	W2	W3	
2~6	16.0(.630)	-	16.5(.650)	22.5(.886)	16.5(.650)	11
7~13	24.0(.945)	-	24.5(.965)	30.5(1.200)	24.5(.965)	9
14~18	32.0(1.260)	28.40(1.118)	32.5(1.280)	38.5(1.516)	32.5(1.280)	7
20,24,26	44.0(1.732)	40.40(1.596)	44.5(1.752)	50.5(1.988)	44.5(1.752)	5

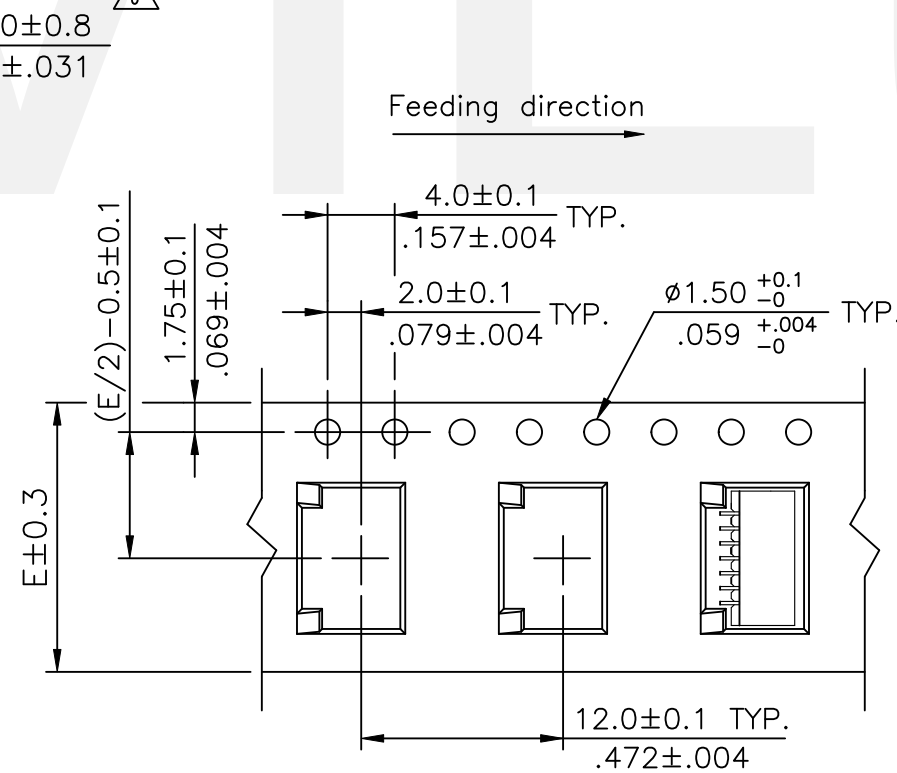
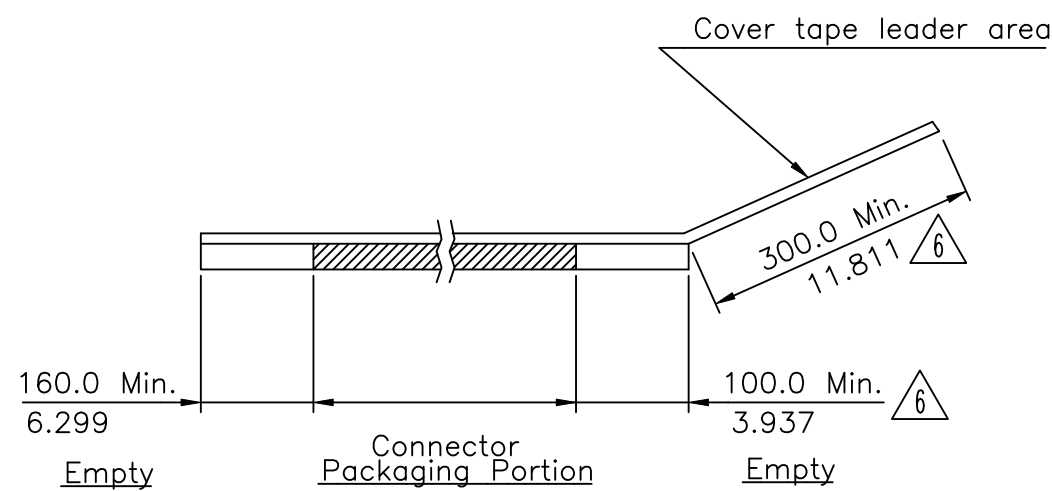

WIDTH : 16,24 mm Carrier

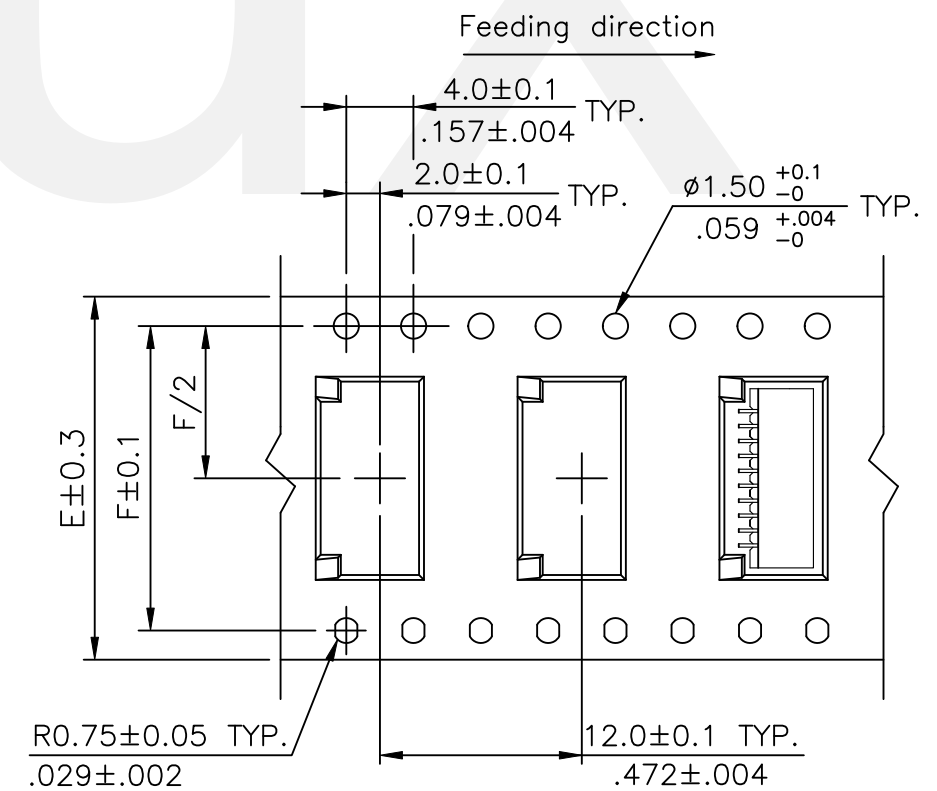

WIDTH : 32,44 mm Carrier

RoHS Compliant

SYM	NAME	DATE	REVISIONS	APPROVED BY:	Eisley	11/22-23'	UNIT: mm / inch	TITLE: 1.00MM(.079") WIRE TO BOARD CONNECTOR	MATERIAL:	FINISH:	DRAWING NO.	C11131SI	PART NO.	C11**M*H*0-NH	SHEET	2	OF	2
⚠️	Amy	11/22-23'	ECNT123179/ECRB123029	DRAWN BY:	Amy	11/22-23'	TOLERANCE UNLESS OTHERWISE SPECIFIED				DRAWING NO.	C11131SI	PART NO.	C11**M*H*0-NH	SHEET	2	OF	2
⚠️	Sun	11/27-19'	ECNT119339	ENGINEER:	Sun	11/22-23'												
⚠️	Ellie	12/19-14'	ECNT114252/ECRT114090	CHECKED BY:	Eisley	11/22-23'												
⚠️	Sun	1/28-14'	ECNT114016	APPROVED BY:	Eisley	11/22-23'												

