

Material:

- * Housing : NYLON 6T WITH 30% GF.
UL 94V-0 Color Black
- * Contact: Phosphor Bronze

Ordering Code

CHC3 ** * M 1 R 0
① ② ③ ④ ⑤ ⑥ ⑦

1. Series No.
2. Contacts : 06 to 36
3. Plating :
 - 1= 120μ" Min. Tin plated over 30μ" Nickel
 - 2= Gold flash plated over 1.27μm(50μ") Nickel
 - 4= 0.76μm(30μ")Gold plated over 1.27μm(50μ") Nickel
 - A= Selective Gold flash plated over Nickel
4. Tail Style : M= SMT Type
5. Color : 1= Black
6. Packing : R= Tape & Reel
T= Tube
7. Other Option : 0= Standard

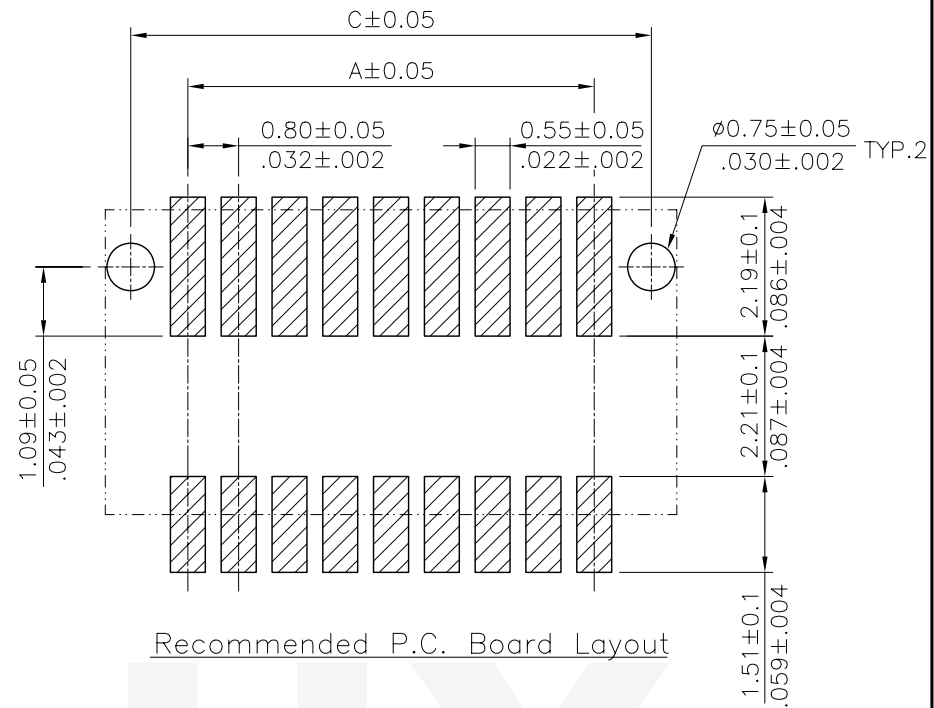
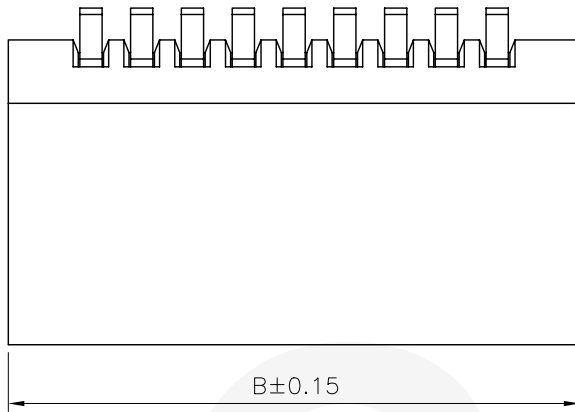

Recommended P.C. Board Layout

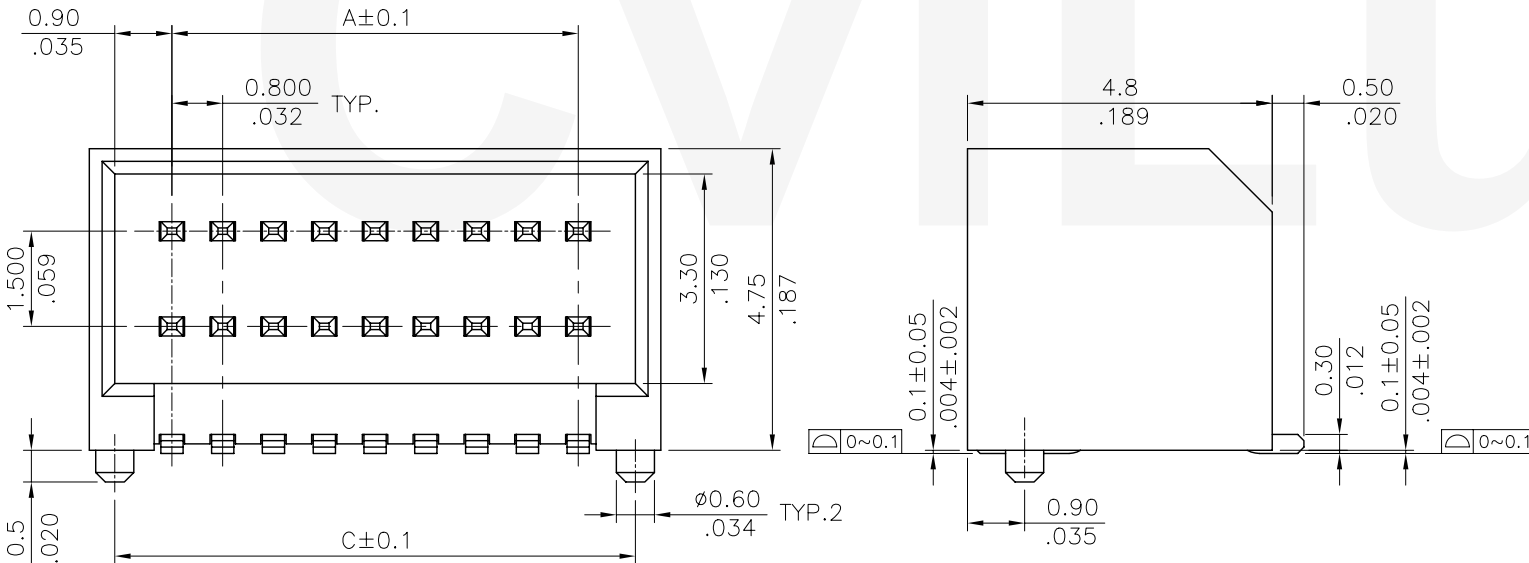

DIM A = 0.8 X No. of Spaces
 DIM B = DIM A + 2.6
 DIM C = DIM A + 1.8
 * AVAILABLE IN 6 THROUGH 36
 CIRCUITS

RoHS Compliant

7	Sun	9/30-08'	ECR08113-1/ECN08475		DATE	UNIT: mm / inch	TITLE: 0.80x1.50mm(.032"x.059")	瀚荃股份有限公司 CviLux Corporation	
6	Karen	8/11-08'	ECN08382		DRAWN BY: Sun	9/30-08'	TOLERANCE UNLESS OTHERWISE SPECIFIED		SMT TYPE BOX HEADER
5	Sandy	04/22-07'	ECN07153		ENGINEER: Eisley	10/1-08'	.X ± 0.25/.010 X: ± 1'		MATERIAL:
4	Jim	3/29/06'	ECN06109		CHECKED BY: David	10/1-08'	.XX ± 0.15/.006 .X' ±		FINISH:
SYM	NAME	DATE	REVISIONS		APPROVED BY: Alex	10/1-08'	.XXX ± 0.08/.003 .XX' ±		
				DRAWING NO.	CHC301SH	PART NO.	CHC3***M1*0		
				SCALE	8 / 1	SHEET	1 OF 2		

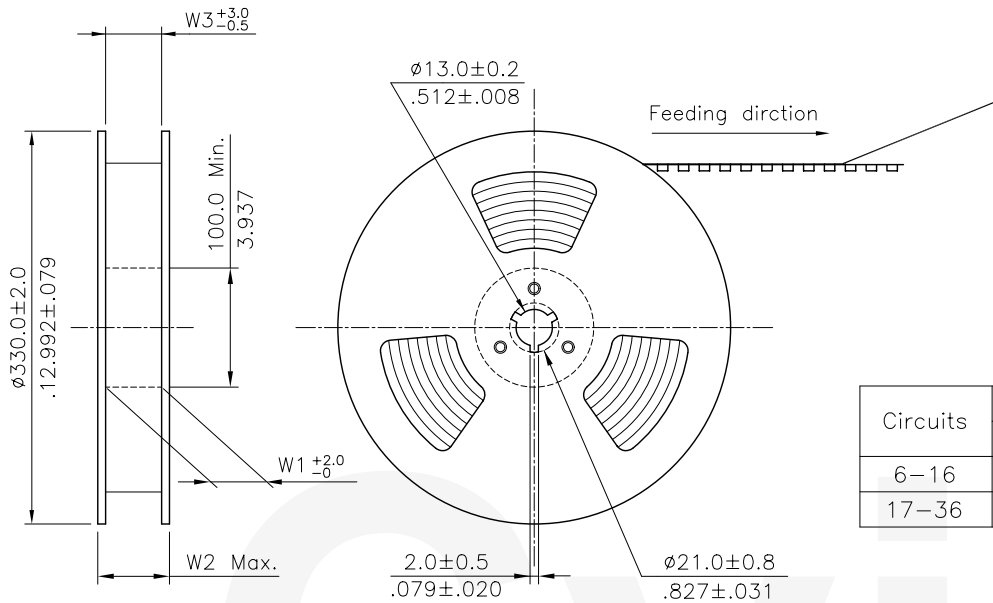

NOTE :

- * Reel Material : HIPS
- △ * Carrier Material : Transparent, Conductive Polystyrene Alloy
- * Cover Tape Material : Polyester
- * Cover Tape Peel Strength : 0.1N – 1.3N
- * Carrier camber is within 1mm in 100mm
- * All dimensions meet EIA-481-B requirements.
- * Quantity : 800 PCS/Reel

Circuits	Dimension					Packing (Reel/Caton)
	E	F	W1	W2	W3	
6-16	16.0(.630)	-	16.5(.650)	22.5(.886)	16.5(.650)	11
17-36	24.0(.945)	-	24.5(.965)	30.5(1.200)	24.5(.965)	9

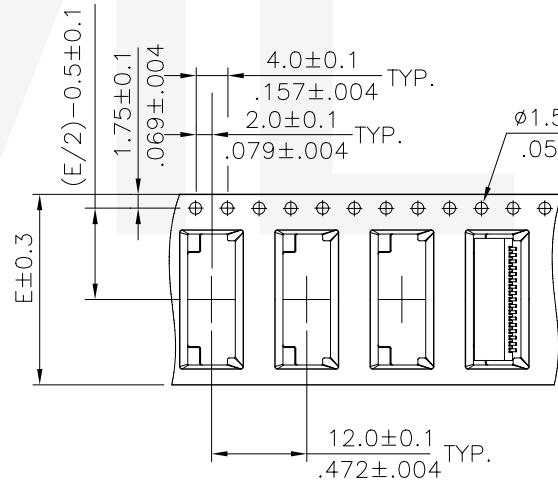
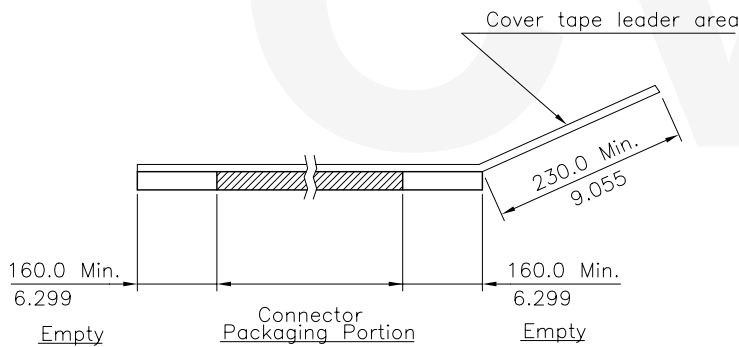

WIDTH : 24 mm Carrier

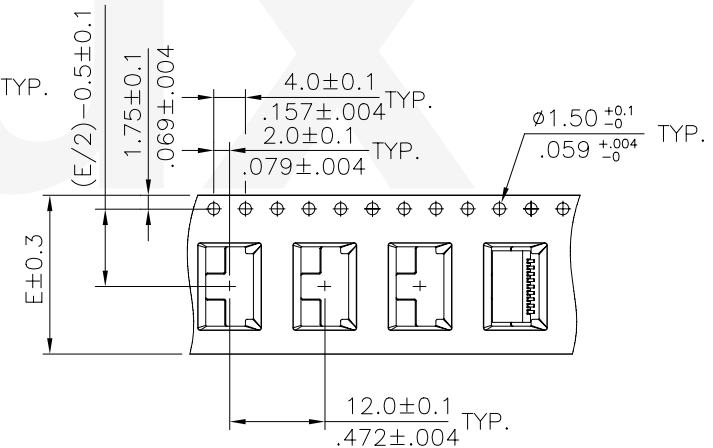

WIDTH : 16 mm Carrier

RoHS Compliant

SYM	NAME	DATE	REVISIONS	APPROVED BY:	DATE	UNIT: mm / inch	TITLE: 0.80x1.50mm(.032"x.059") SMT TYPE BOX HEADER	 瀚荃股份有限公司 CviLux Corporation
7	Sun	9/30-08'	ECR08113-1/ECN08475					
6	Karen	8/11-08'	ECN08382	DRAWN BY: Sun	9/30-08'	TOLERANCE UNLESS OTHERWISE SPECIFIED	MATERIAL:	
5	Sandy	04/22-07'	ECN07153	ENGINEER: Eisley	10/1-08'	.X ± X' ± 1'	FINISH:	
4	Jim	3/29/06'	ECN06109	CHECKED BY: David	10/1-08'	.XX ± .X' ±		
				APPROVED BY: Alex	10/1-08'	.XXX ± .XX' ±		

CIVILUX.XORP
 2008.10.07
 ISSUED