

Ordering Code

CB50 ** 2 0 0 T 0
 ① ② ③ ④ ⑤ ⑥ ⑦

1. Series No.
2. Contacts: 50~60
3. Plating option :
 1= 3.05μm(120μ") Min. Tin plated over 1.27μm(50μ") Nickel
 2= 0.05μm(2μ") Min. Gold flash over 1.27μm(50μ") Nickel
 3= 0.38μm(15μ") Min. Gold plated over 1.27μm(50μ") Nickel
 4= 0.76μm(30μ") Min. Gold plated over 1.27μm(50μ") Nickel
4. 0= Without Peg , P= With Peg
5. 0= Without Pick & Place Pad,P= With Pick & Place Pad
6. Packing: R=Tape & Reel ,T= Tube Packaged
7. Other Option: 0= LCP(Standard), M= Nylon 9T

△ * The one with both Peg and Pad is with Tape & Reel packing only.

For Bottom entry mounting style

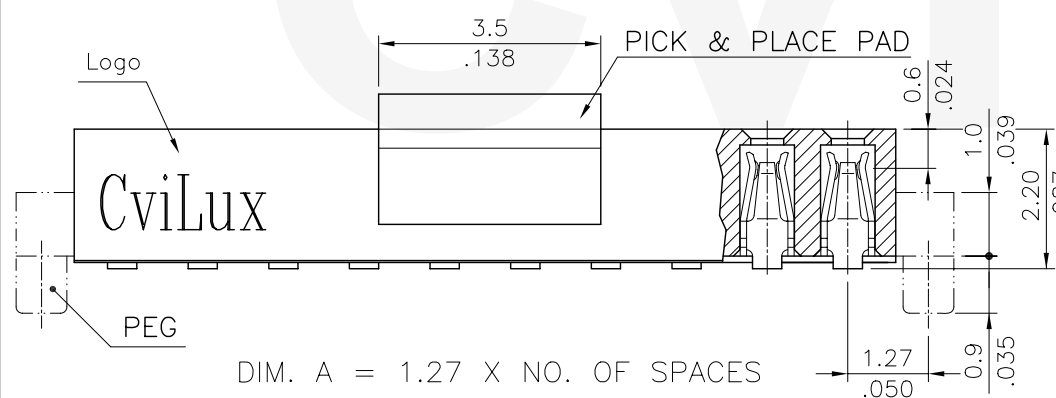
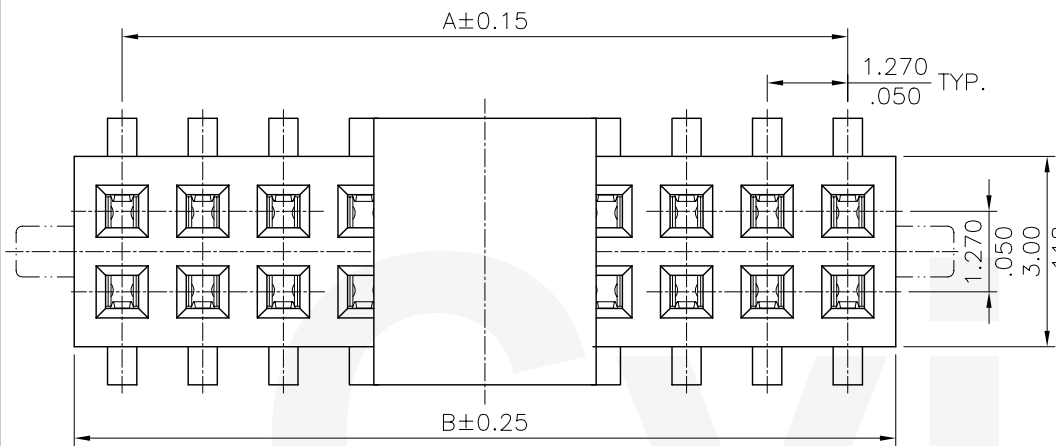

DIM. A = 1.27 X NO. OF SPACES
 DIM. B = DIM. A + 1.67

△ * AVAILABLE IN 50 THROUGH 60 CIRCUITS

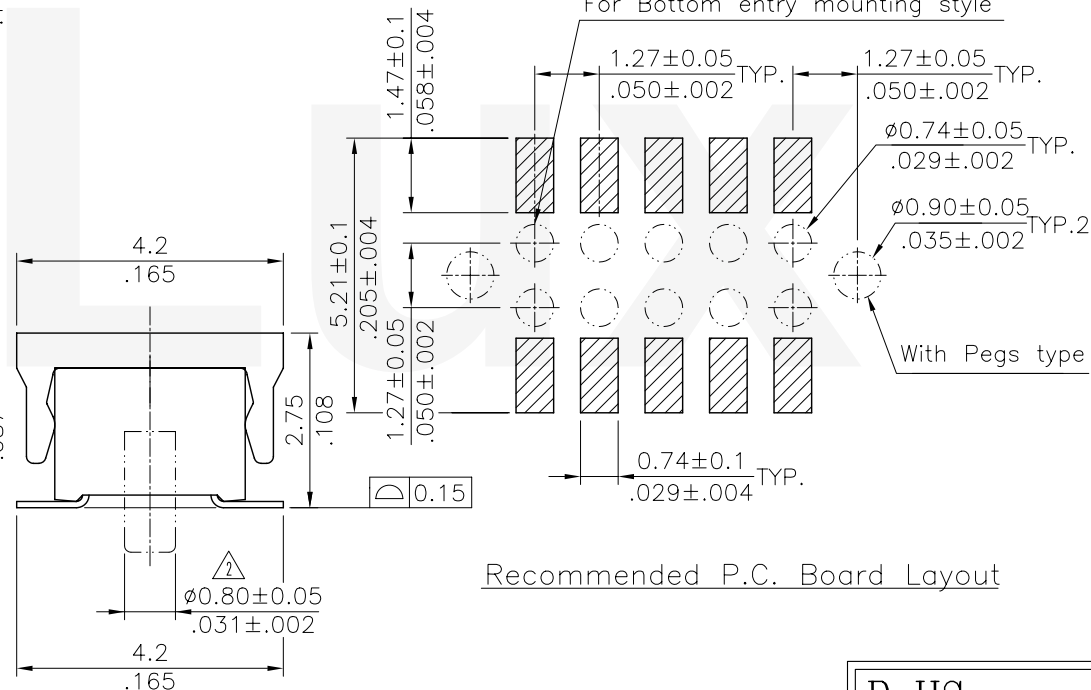

Recommended P.C. Board Layout

RoHS Compliant

④	Sun	11/9-09'	ECR06081-0/ECN06356		DATE	UNIT: mm / inch	TITLE: LOW PROFILE 1.27*1.27MM SMT TYPE SOCKET	 瀚荃股份有限公司 CviLux Corporation
③	Sandy	5/28-07'	ECR07023-1/ECN07188	DRAWN BY: Sun	11/13-09'	TOLERANCE UNLESS OTHERWISE SPECIFIED	MATERIAL:	
②	Sandy	1/10-07'	ECN07019	ENGINEER: Easley	11/16-09'	.X ± 0.25/.010 X: ± 1'	FINISH:	
①	Sun	9/25-06'	ECR06081-0/ECN06356	CHECKED BY: Easley	11/16-09'	.XX ± 0.15/.006 .X' ±	DRAWING NO. CB5010SE PART NO. CB50*****	
SYM	NAME	DATE	REVISIONS	APPROVED BY: Alex	11/16-09'	.XXX ± 0.08/.003 .XX' ±	SCALE 8 / 1 SHEET 1 OF 1	

CVILUX CORP
 2009.12.01
 ISSUED