

Material :

- * Body : High Temperature plastic UL 94V-0
Color Nature
- * Slider : Glass filled Polyamide UL 94V-0
Color Black
- * Contact : Copper alloy
- * Fixed tab : Copper alloy

Ordering Code

CF30 ** 2 D 0 R A
① ② ③ ④ ⑤ ⑥ ⑦

- ① Series No.
- ② No. of Circuits
- ③ Plating code:
2= Gold flash over 0.76μm(30μ") Nickel
- ④ Contact style: D= Downside contact
- ⑤ Color: 0= Nature
- ⑥ Packing option: R= Tape & Reel
- ⑦ Other option: A= Lead-Less Type

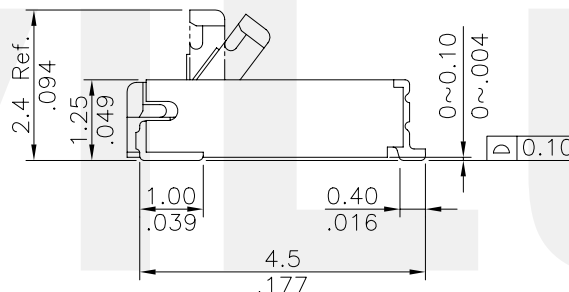
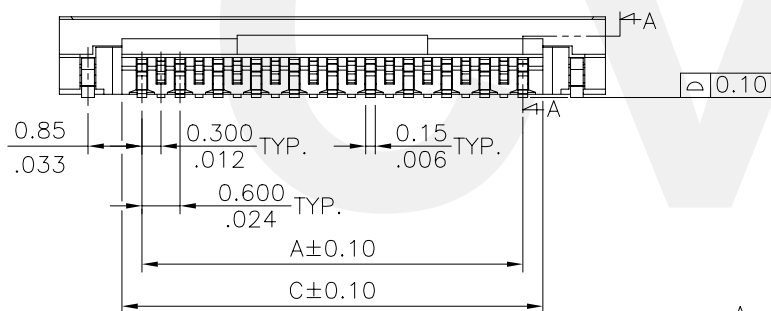

A = 0.30 * (No. of Contacts - 1)
 A1 = A - 0.6
 B = A + 2.6
 C = A + 0.63

* AVAILABLE IN 11 THROUGH 61 CIRCUITS

Lead Free Process

RoHS Compliant

⑤	Karen	1/05-08'	ECN09003/ECR08099-0		DATE	UNIT: mm / inch	TITLE: 0.30mm(.012") ZIF FPC ONE-TOUCH CONNECTOR (H= 1.25mm)	 瀚荃股份有限公司 CviLux Corporation	
④	Bill	6/13-08'	ECN08216		DRAWN BY: Karen	1/8-09'	TOLERANCE UNLESS OTHERWISE SPECIFIED		MATERIAL:
③	Sun	5/09-08'	ECN08210		ENGINEER: Eisley	1/9-09'	.X ± 0.15/.006 .X' ± 1'		FINISH:
②	Bill	1/23-08	ECN08038		CHECKED BY: David	1/7-09'	.XX ± 0.10/.004 .X' ±	DRAWING NO. CF3001SF	PART NO. CF30**2DORA
SYM	NAME	DATE	REVISIONS		APPROVED BY: Alex	1/7-09'	.XXX ± 0.05/.002 .XX' ±	SCALE 8 / 1	SHEET 1 OF 3

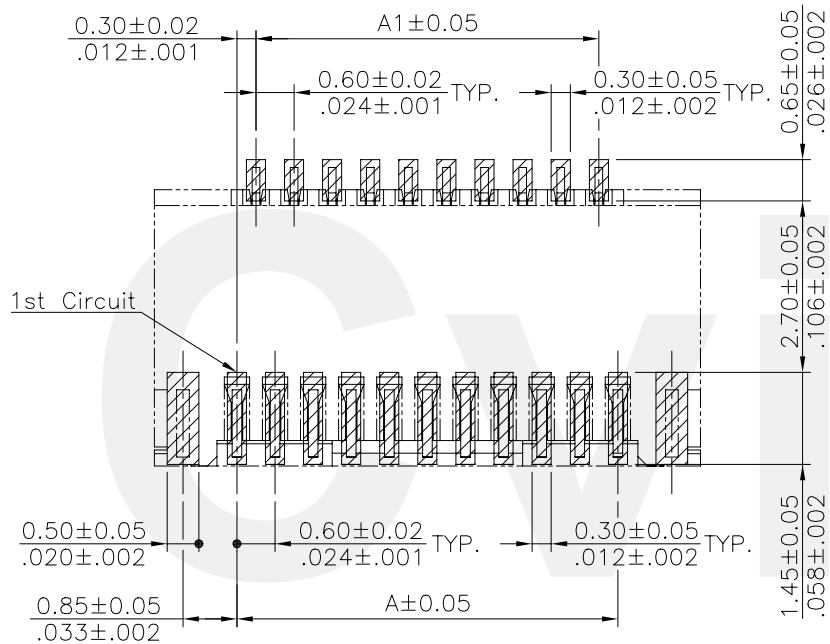

Recommended P.C. Board Layout

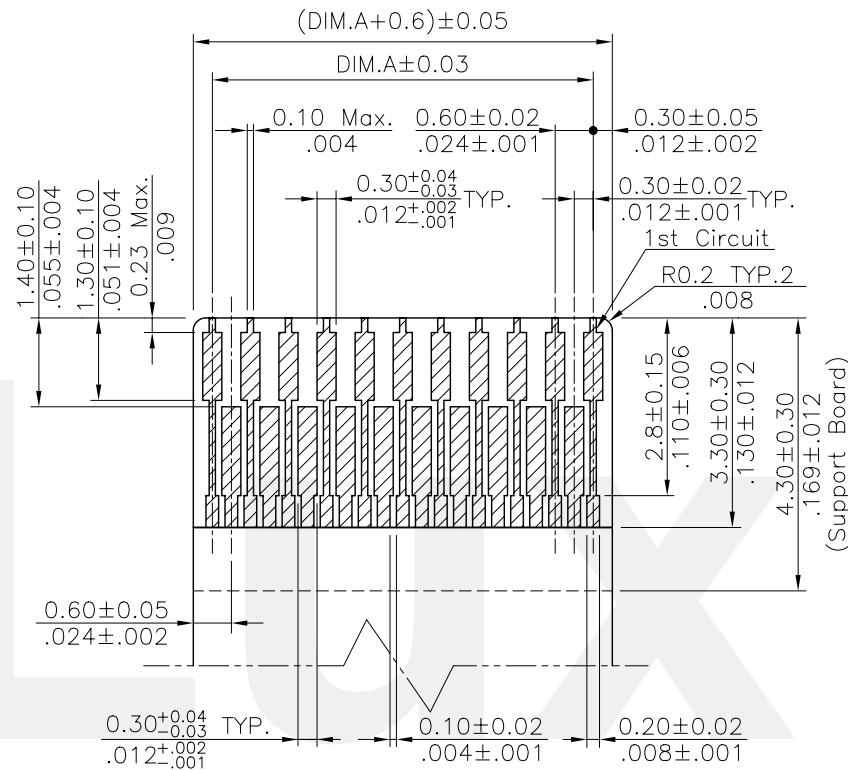

Recommended FPC Dimension

Thickness: 0.2±0.03mm

Lead Free Process

RoHS Compliant

5	Karen	1/05-08'	ECN09003/ECR08099-0			DATE	UNIT: mm / inch	TITLE: 0.30mm(.012") ZIF FPC ONE-TOUCH CONNECTOR (H= 1.25mm)	 瀚荃股份有限公司 CviLux Corporation		
4	Bill	6/13-08'	ECN08216		DRAWN BY: Karen	1/8-09'	TOLERANCE UNLESS OTHERWISE SPECIFIED			MATERIAL:	
3	Sun	5/09-08'	ECN08210		ENGINEER: Eisley	1/9-09'	.X ± 0.15/.006	.X' ± 1'			
2	Bill	1/23-08	ECN08038		CHECKED BY: David	1/7-09'	.XX ± 0.10/.004	.X' ±	FINISH:	DRAWING NO. CF3001SF	PART NO. CF30**2DORA
SYM	NAME	DATE	REVISIONS		APPROVED BY: Alex	1/7-09'	.XXX ± 0.05/.002	.XX' ±		SCALE 8 / 1	SHEET 2 OF 3

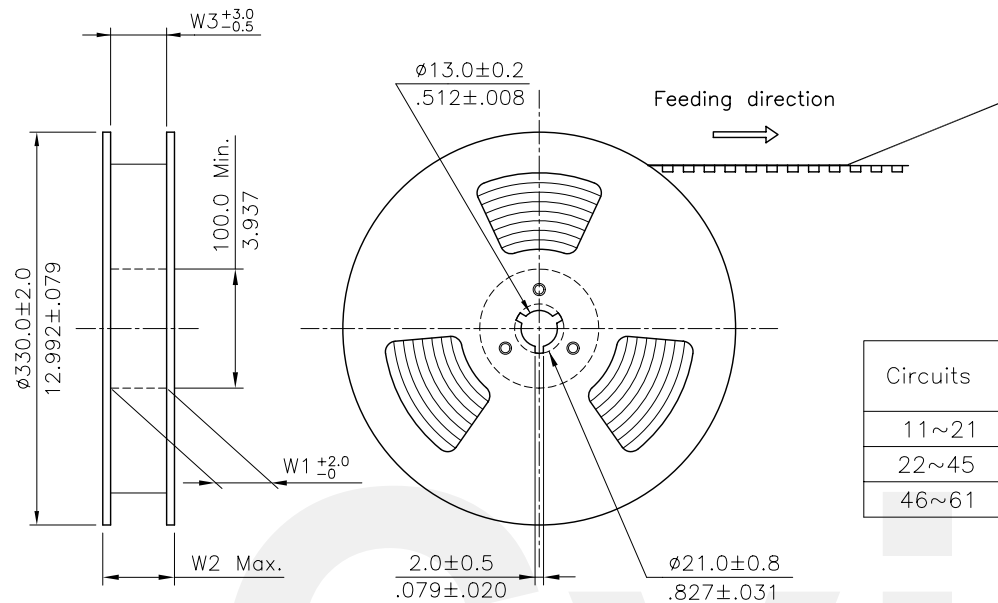

NOTE :

1. 10 sprocket hole pitch cumulative tolerance ± 0.20 .
2. Carrier camber is within 1 mm in 250mm.
3. Material : Clear,Transparent Polystyrene Alloy (UP-5200).
4. All dimensions meet EIA-481-C requirements.
5. Thickness : 0.40 ± 0.05 mm.
6. Packing length per 22" reel : 92.5 Meters.
7. Component load per 13" reel : 2400 pcs.

Circuits	Dimension					Packing (Reel/Caton)
	E	F	W1	W2	W3	
11~21	16.0(.630)	—	16.5(.650)	22.5(.886)	16.5(.650)	11
22~45	24.0(.945)	—	24.5(.965)	30.5(1.201)	24.5(.965)	9
46~61	32.0(1.260)	28.40(1.118)	32.5(1.280)	38.5(1.516)	32.5(1.280)	7

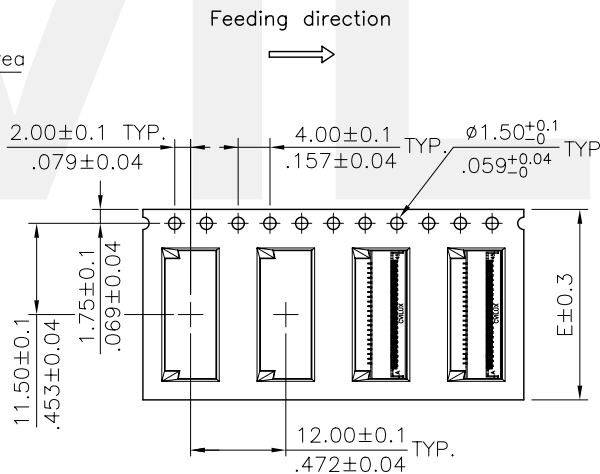
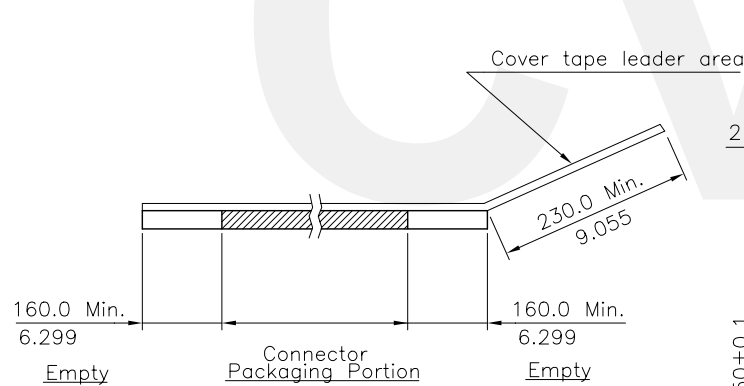

WIDTH : 16,24 mm Carrier

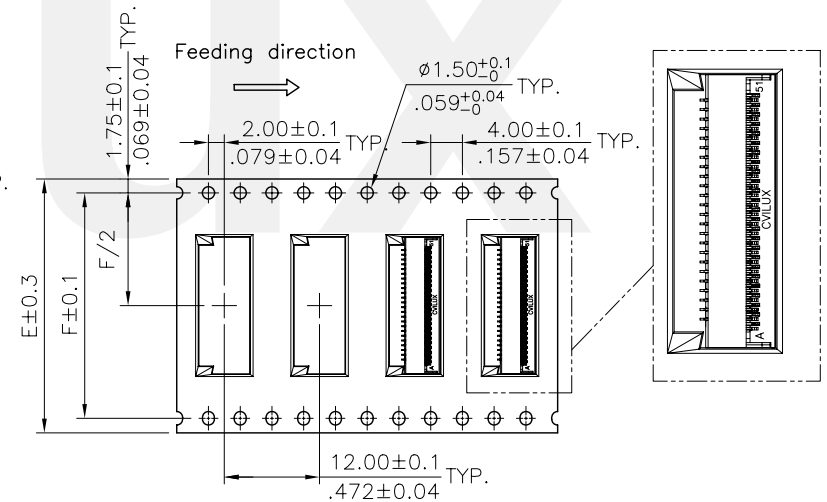

WIDTH : 32 mm Carrier

RoHS Compliant

SYM	NAME	DATE	REVISIONS	APPROVED BY:	DATE	UNIT: mm / inch	TITLE: TAPE & REEL PACKAGING FOR CF30 SERIES	瀚荃股份有限公司 CviLux Corporation			
5	Karen	1/05-08'	ECN09003/ECR08099-0		DATE	UNIT: mm / inch	TITLE: TAPE & REEL PACKAGING FOR CF30 SERIES	DRAWING NO.	CF3001SF	PART NO.	CF30**2DORA
4	Bill	6/13-08'	ECN08216		DRAWN BY: Karen	1/8-09'	TOLERANCE UNLESS OTHERWISE SPECIFIED				
3	Sun	5/09-08'	ECN08210		ENGINEER: Eisley	1/9-09'	.X ± X' ± 1'	FINISH:			
2	Bill	1/23-08	ECN08038		CHECKED BY: David	1/7-09'	.XX ± .X ±				
					APPROVED BY: Alex	1/7-09'	.XXX ± .XX ±				