

### ORDERING CODE

CI08 \*\* P \* H R \* -NH  
 ① ② ③ ④ ⑤ ⑥ ⑦ ⑧

- ① Series No.
- ② Contact: 03 to 10
- ③ P= DIP Type
- ④ Plating :  
 1= 2.54μm(100u") Min. Matte Tin Plating on Contact area and Solderails, 1.27um(50u") Nickel Underplating over all  
 2= 0.03um(1.2u") Min. Gold Flash Plating on Contact area and Solderails, 1.27um(50u") Nickel Underplating over all
- ⑤ Contact type: H= Side entry
- ⑥ Packing option:  
 R= Tape & Reel Packing
- ⑦ Other option:  
 0= DIM.E=0.9 DIM.F=1.0, 1= DIM.E=0.9 DIM.F=1.2  
 2= DIM.E=1.3 DIM.F=1.0, 4= DIM.E=1.3 DIM.F=1.2
- ⑧ -NH= For Lead Free IR Processes and Halogen-Free

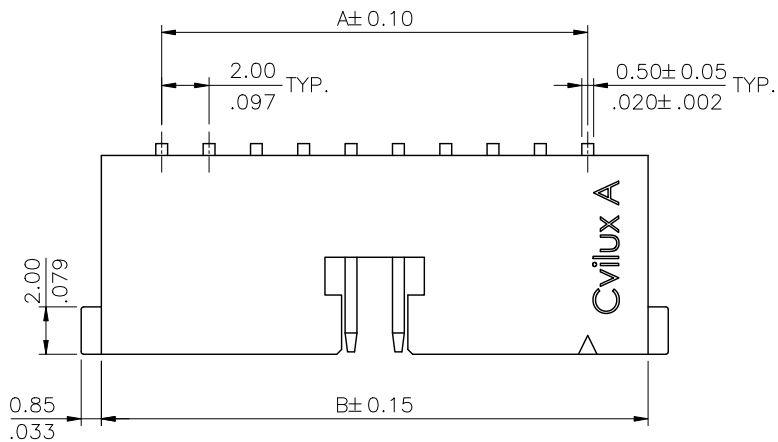

Note:

- \* Insulator: Halogen Free Plastic  
UL 94V-0 Color Black
- \* Contact: Brass
- \* For Lead Free IR Reflow process

DIM. A = 2.00 × NO. OF SPACES  
 DIM. B = DIM. A + 5.1  
 DIM. C = DIM. A + 2.6  
 DIM. D = DIM. A + 0.4

\* AVAILABLE IN 3 THROUGH 10

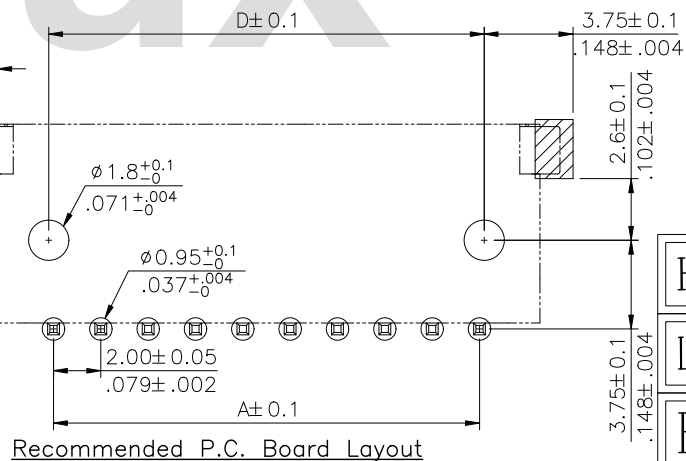
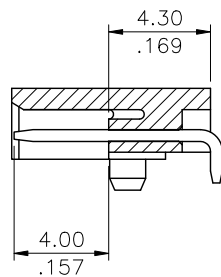
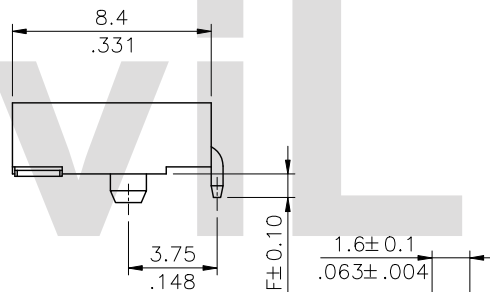
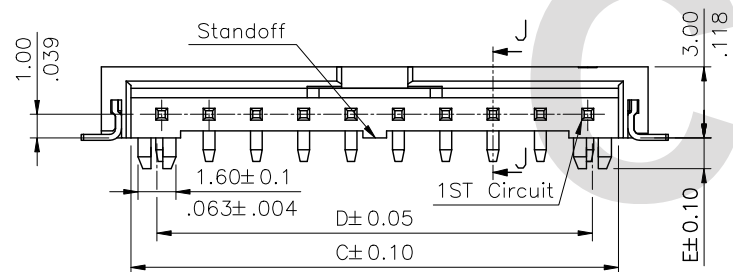

Halogen-Free  
 Lead Free Process  
 RoHS Compliant

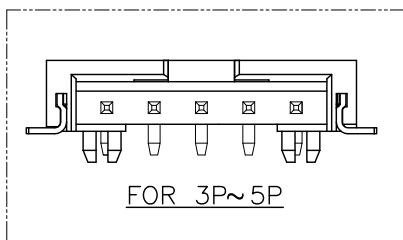

4					DATE	UNIT: mm / inch	TITLE: 2.0mm Pitch WTB DIP R/A TYPE
3				DRAWN BY: Hank	3/3-14'	TOLERANCE UNLESS OTHERWISE SPECIFIED	MATERIAL:
2				ENGINEER: Eisley	3/3-14'	.X ± 0.30/.012 X' ± 1'	FINISH:
1				CHECKED BY: David	3/3-14'	.XX ± 0.20/.008 X' ±	
				APPROVED BY: David	3/3-14'	.XXX ± 0.10/.004 .XX' ±	
SYM	NAME	DATE	REVISIONS				

CVILUX CORP.  
 2014.03.12  
 ISSUED

瀚荃股份有限公司  
 Cvilux Corporation

DRAWING NO.	CI080BSA	PART NO.	CI08**P*HR*-NH
SCALE	3 / 1	SHEET	1 OF 2

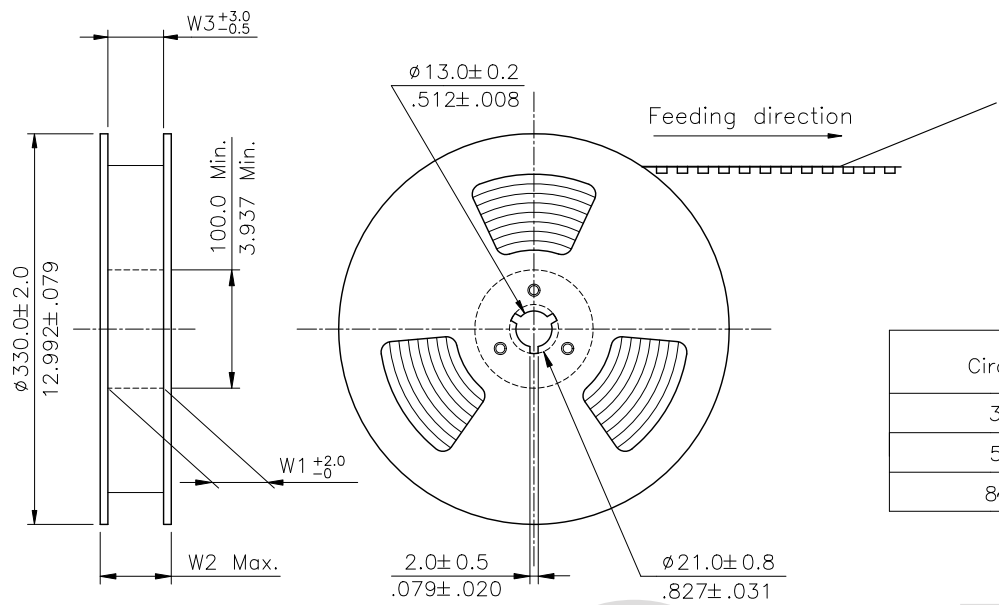

NOTE :

- \* Reel Material : Corrugated Paper
- \* Carrier Material : Black, Polystyrene alloy
- \* Cover Tape Material : Polyester
- \* Cover Tape Peel Strength : 0.1N - 1.3N
- \* Carrier camber is within 1mm in 100mm
- \* All dimensions meet EIA-481-2 & EIA-481-3 requirements.
- \* Quantity : 800 PCS/Reel

Circuits	Dimension					Packing (Reel/Caton)
	E	F	W1	W2	W3	
3~4	24.0(.945)	—	24.5(.965)	30.5(1.200)	24.5(.965)	9
5~7	32.0(1.260)	28.4(1.118)	32.5(1.280)	38.5(1.516)	32.5(1.280)	7
8~10	44.0(1.732)	40.4(1.596)	44.5(1.752)	50.5(1.988)	44.5(1.752)	5

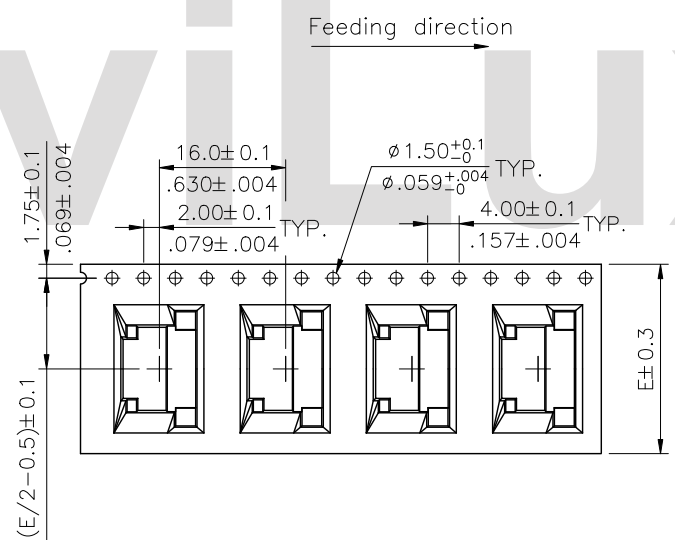
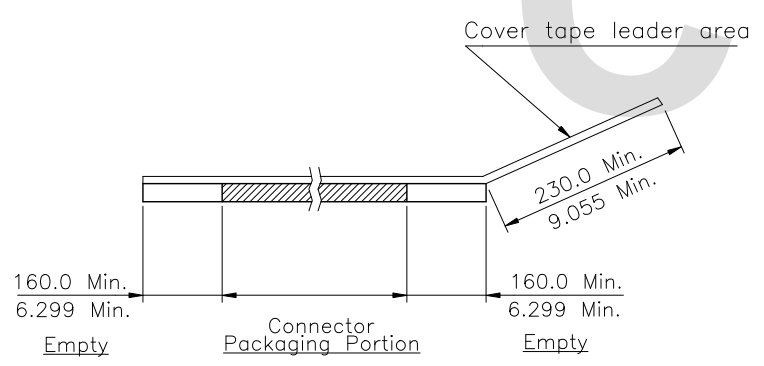

WIDTH : 24 mm Carrier

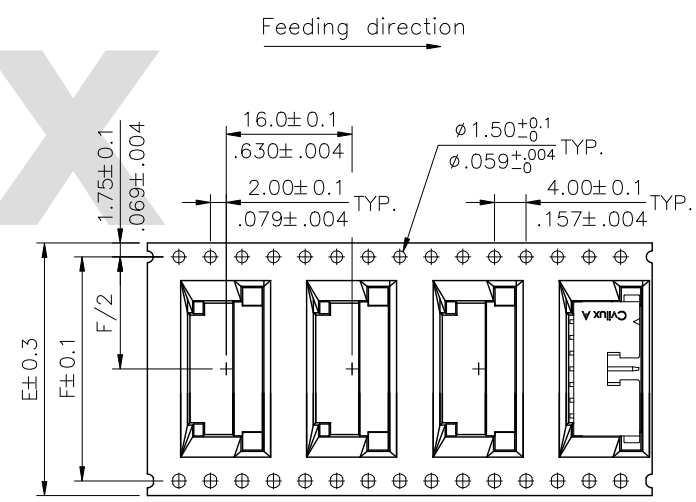

WIDTH : 32.44 mm Carrier

RoHS Compliant

4					DATE	UNIT: mm / inch	TITLE: 2.0mm Pitch WTB DIP R/A TYPE	 瀚荃股份有限公司 CviLux Corporation
3				DRAWN BY: Hank	3/3-14'	TOLERANCE UNLESS OTHERWISE SPECIFIED	MATERIAL:	
2				ENGINEER: Eisley	3/3-14'	.X ±      X' ± 1'		
1				CHECKED BY: David	3/3-14'	.XX ±     X'' ±	FINISH:	
				APPROVED BY: David	3/3-14'	.XXX ±    .XX ±		
SYM	NAME	DATE	REVISIONS					DRAWING NO. CI0808SA
								PART NO. CI08**P*HR*-NH
								SHEET 2 OF 2

CVILUX CORP.  
 2014.03.12  
 ISSUED