

Note:

Material :

- \* Base : High Temperature plastic UL 94V-0  
Black Color
- \* Contact : Copper alloy
- \* Fixed tab : Matte Tin plated over Nickel  
For Lead Free IR Reflow Process

Ordering Code:

CI46 \*\* M 1 H R B -NH  
① ② ③ ④ ⑤ ⑥ ⑦ ⑧

- ① Series No.
- ② No. of Circuits: 08~15 Pin
- ③ M= SMT Type
- ④ Plating: 1=  $3.05 \mu\text{m}(120 \mu\text{'}) \sim 4.88 \mu\text{m}(192 \mu\text{'})$   
Matte Tin over  $1.27 \mu\text{m}(50 \mu\text{'})$  Nickel
- ⑤ Type: H= Side Entry
- ⑥ Packing Options: R= Tape & Reel packing
- ⑦ Option: B= TYPE B (Black color)
- ⑧ Other option:  
-NH= For Lead Free IR Processes  
and Halogen-Free

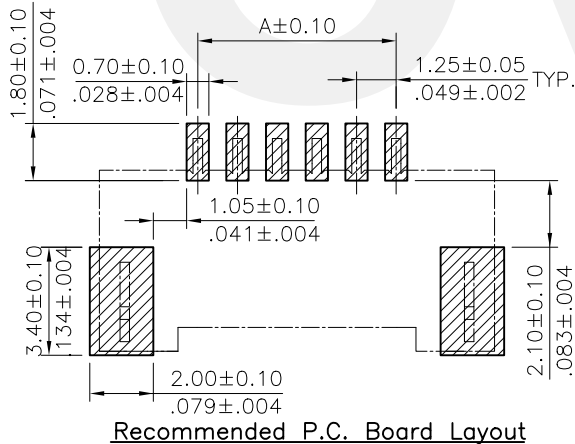
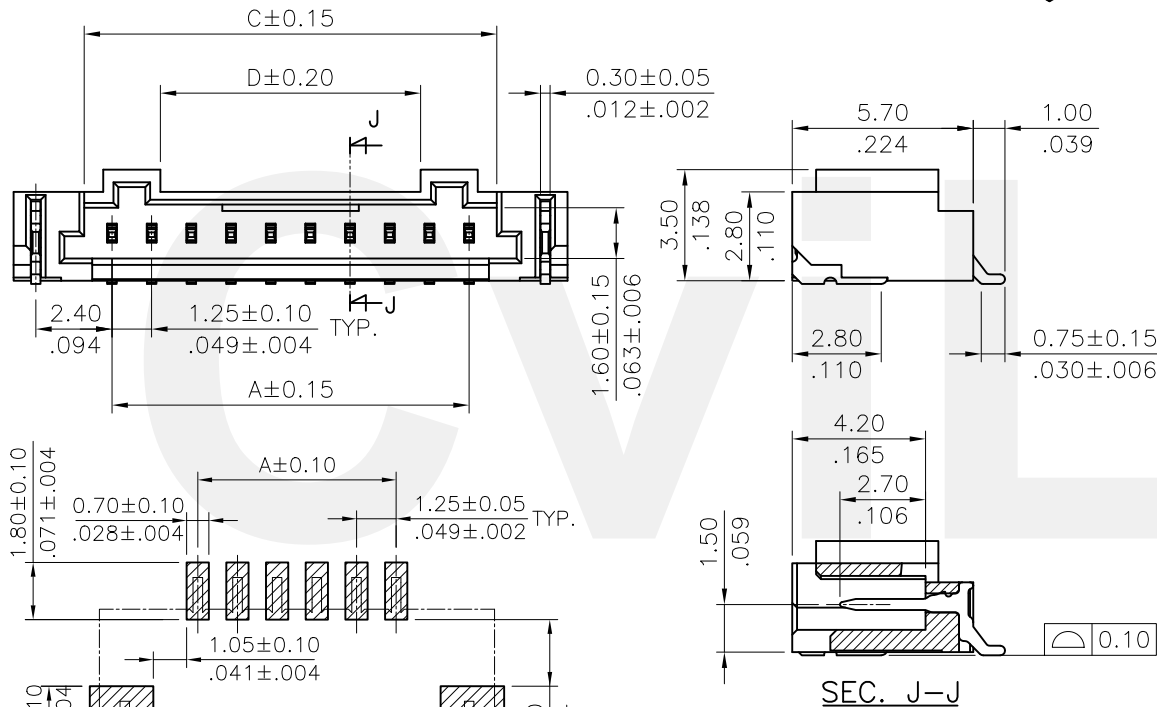

Dim.A = 1.25 x No. of Spaces

Dim.B = Dim.A + 6.20

Dim.C = Dim.A + 1.75

Dim.D = Dim.A - 3.05

\* Available in 8 through 15 circuits

Halogen-Free

Lead Free Process

RoHS compliant

Circuits	Dimension
	E
08~12	4.30(.169)
13~15	7.20(.283)

④					DATE	UNIT: mm / inch	TITLE: 1.25mm Pitch WTB SMT R/A TYPE
③				DRAWN BY: Clark	7/4-16'	TOLERANCE UNLESS OTHERWISE SPECIFIED	MATERIAL: CUSTOMER:
②				ENGINEER: Clark	7/4-16'	.X ± 0.30/012 X' ± 1'	
①	Clark	06/22-16	ECNT116134	CHECKED BY: Eisley	7/6-16'	.XX ± 0.20/008 X' ±	
SYM	NAME	DATE	REVISIONS	APPROVED BY: Eisley	7/6-16'	.XXX ± 0.10/004 XX' ±	



瀚荃股份有限公司  
CviLux Corporation

DRAWING NO.	CI4615SA	PART NO.	CI46**M1HRB-NH
SCALE	4 / 1	SHEET	1 OF 2

NOTE :

- \* Reel Material : Corrugated Paper
- \* Carrier Material : Black, Polystyrene alloy
- \* Cover Tape Material : Polyester
- \* Cover Tape Peel Strength : 0.1N – 1.3N
- \* Carrier camber is within 1mm in 100mm
- \* All dimensions meet EIA-481-2 & EIA-481-3 requirements.
- \* Quantity : 1400 PCS/Reel

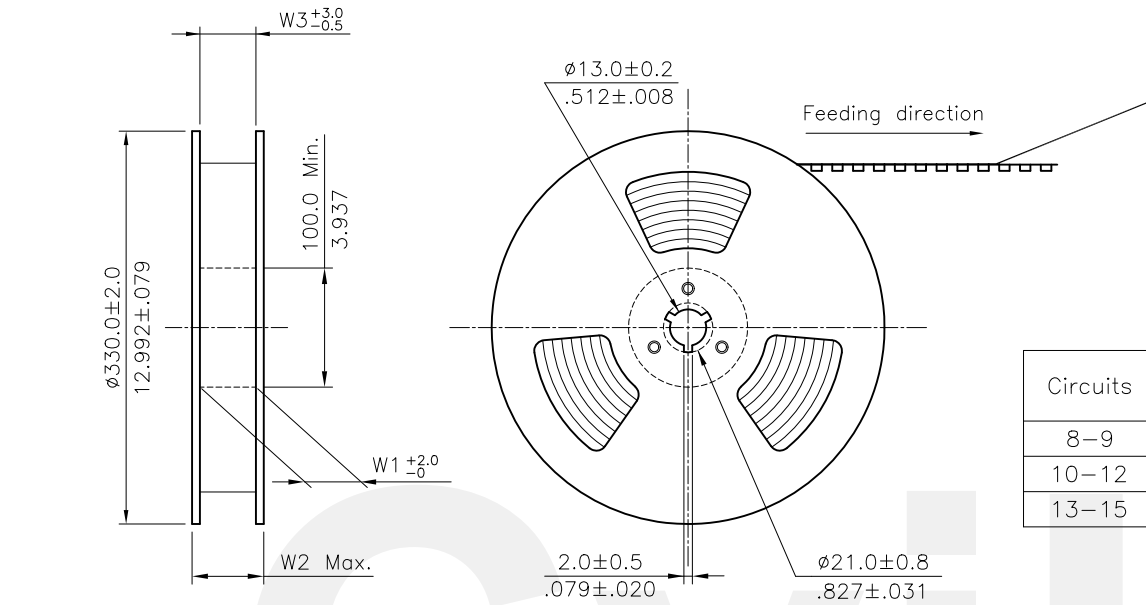

Circuits	Dimension					Packing (Reel/Carton)
	E	F	W1	W2	W3	
8-9	24.0(.945)	-	24.5(.965)	30.5(1.201)	24.5(.965)	9
10-12	32.0(1.260)	28.40(1.118)	32.5(1.280)	38.5(1.516)	32.5(1.280)	7
13-15	44.0(1.732)	40.40(1.591)	44.5(1.752)	50.5(1.988)	44.5(1.752)	5

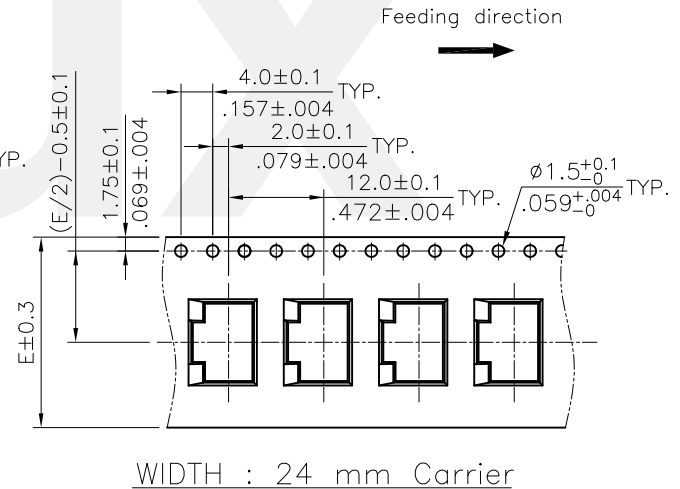
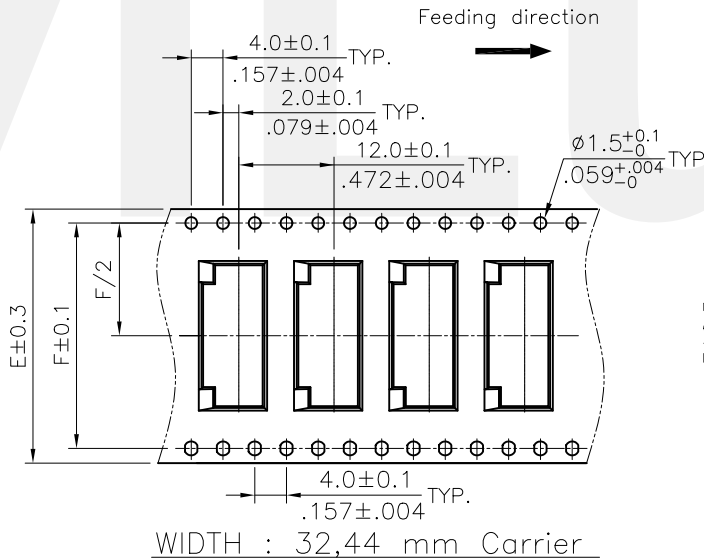
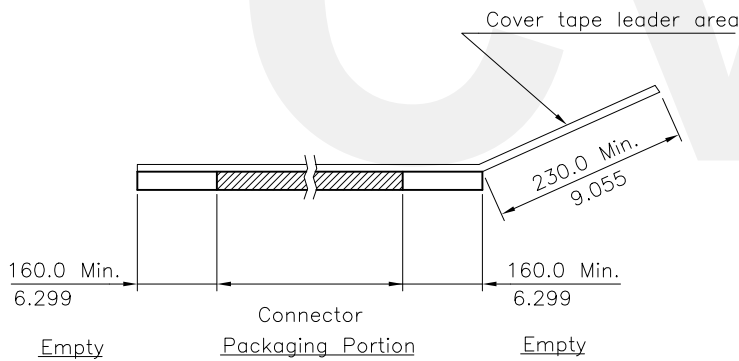

RoHS Compliant

4					DATE	UNIT: mm / inch	TITLE: 1.25mm Pitch WTB SMT R/A TYPE	 瀚荃股份有限公司 CviLux Corporation
3					DRAWN BY: Clark	TOLERANCE UNLESS OTHERWISE SPECIFIED	MATERIAL:	
2					ENGINEER: Clark	.X ±      .X' ± 1'	CUSTOMER:	DRAWING NO. CI4615SA
1	Clark	06/22-16	ECNT116134		CHECKED BY: Eisley	.XX ±      .X ±		PART NO. CI46**M1HRB-NH
SYM	NAME	DATE	REVISIONS		APPROVED BY: Eisley	.XXX ±      .XX ±		SCALE
								SHEET 2 OF 2

CIVILUX CORP  
2016.07.07  
ISSUED