

Material :

- * Base: High temperature plastic UL94 V-0, Color Nature
- * Cover: High temperature plastic UL94 V-0, Color Black
- * Contact: Phosphor Bronze
- * Fixed tab: Brass with 100u" Min. Matte Tin plated over 50u" Min. Nickel.

Ordering Code

CF69 40 * D 0 * 0 -05 -NH
 ① ② ③ ④ ⑤ ⑥ ⑦ ⑧ ⑨

- ① Series No.
- ② No. of Circuits: 40= 40 Pin
- ③ Plating code:
 - 1= 2.00um(80u") Min. Matte Tin Plating on Contact area and Solderails, 1.27um(50u") Nickel Underplating over all
 - 2= Gold Flash Plating on Contact area and Solderails, 1.27um(50u") Nickel Underplating over all
- ④ Contact style: D= Downside contact
- ⑤ 0= Color Nature
- ⑥ Packing: R= Tape & Reel packing
T= Tube Packing
- ⑦ Option: 0= Standard
- ⑧ -05= 0.5 Pitch
- ⑨ -NH= For Lead Free IR Processed and Halogen Free

Halogen-Free Lead Free Process RoHS compliant

④					DATE	UNIT: mm / inch	TITLE: 0.50mm(.020") ZIF FFC/FPC ONE-TOUCH CONNECTOR	瀚荃股份有限公司 CviLux Corporation	
③					DRAWN BY: Clark	1/4-17'	MATERIAL:		
②					ENGINEER: Clark	1/4-17'		FINISH:	
①	Clark	01/03-17	ECNT117002		CHECKED BY: Eisley	1/6-17'	DRAWING NO. CF6901SA		PART NO. CF6940*D0*0-05-NH
SYM	NAME	DATE	REVISIONS		APPROVED BY: Eisley	1/6-17'	SCALE	5 / 1	SHEET 1 OF 3

CIVILUX CORP
 2017.02.03
 ISSUED

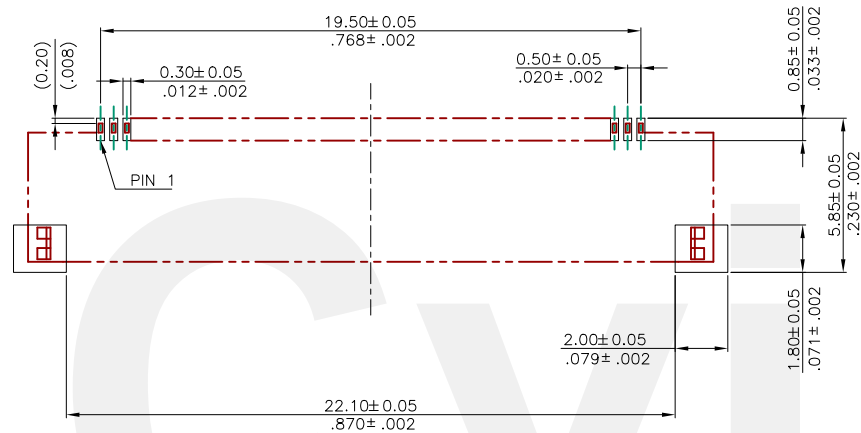

RECOMMENDED PCB LAYOUT

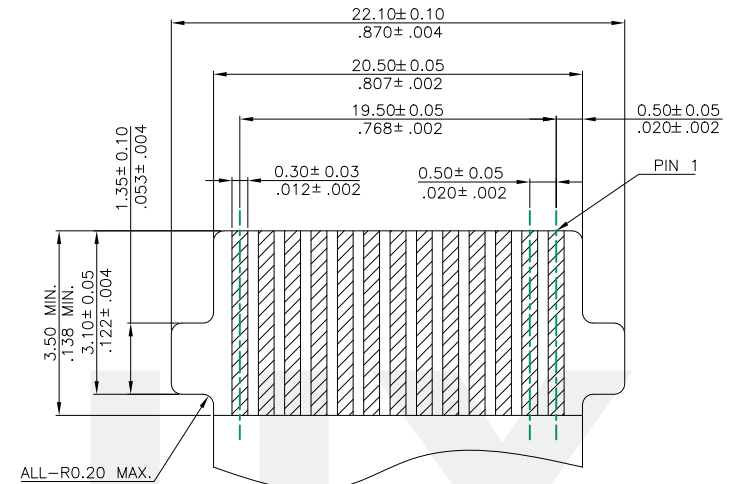

THICKNESS:0.3±0.03
APPLICABLE FFC/FPC DIM.(REF)

Halogen-Free Lead Free Process RoHS compliant

4					DATE	UNIT: mm / inch	TITLE: 0.50mm(.020") ZIF FFC/FPC ONE-TOUCH CONNECTOR	 瀚荃股份有限公司 CviLux Corporation
3				DRAWN BY: Clark	1/4-17'	TOLERANCE UNLESS OTHERWISE SPECIFIED	MATERIAL:	
2				ENGINEER: Clark	1/4-17'	.X ± 0.25/.010 .X' ±	FINISH:	DRAWING NO. CF6901SA PART NO. CF6940*DO*0-05-NH
1	Clark	01/03-17	ECNT117002	CHECKED BY: Eisley	1/6-17'	.XX ± 0.15/.006 .X' ± 2'		SCALE 5 / 1
SYM	NAME	DATE	REVISIONS	APPROVED BY: Eisley	1/6-17'	.XXX ± .XX ±		



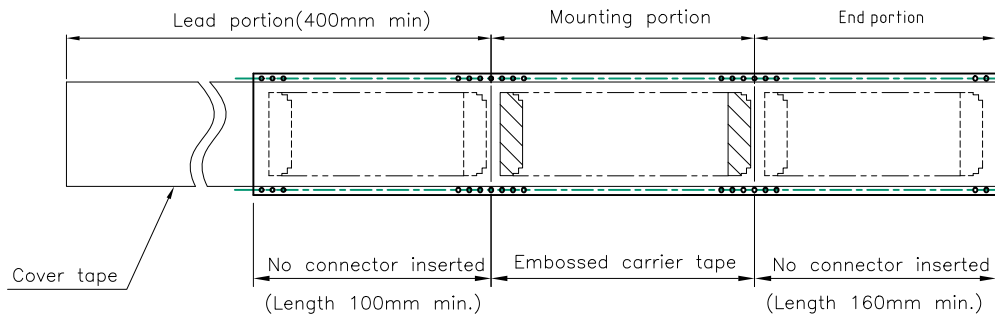

Notes:

1. 10 sprocket hole pitch cumulative tolerance ± 0.2
2. Material: Polystyrene.
3. Quantity: 2000 Pcs/Reel
4. All dimensions meet EIA-481-B requirements.

Circuits	Dimension		Packing (Reel/Caton)
	W	F	
40	44.0(1.732)	20.20(.795)	5

TAPE RUNNING DIRECTION

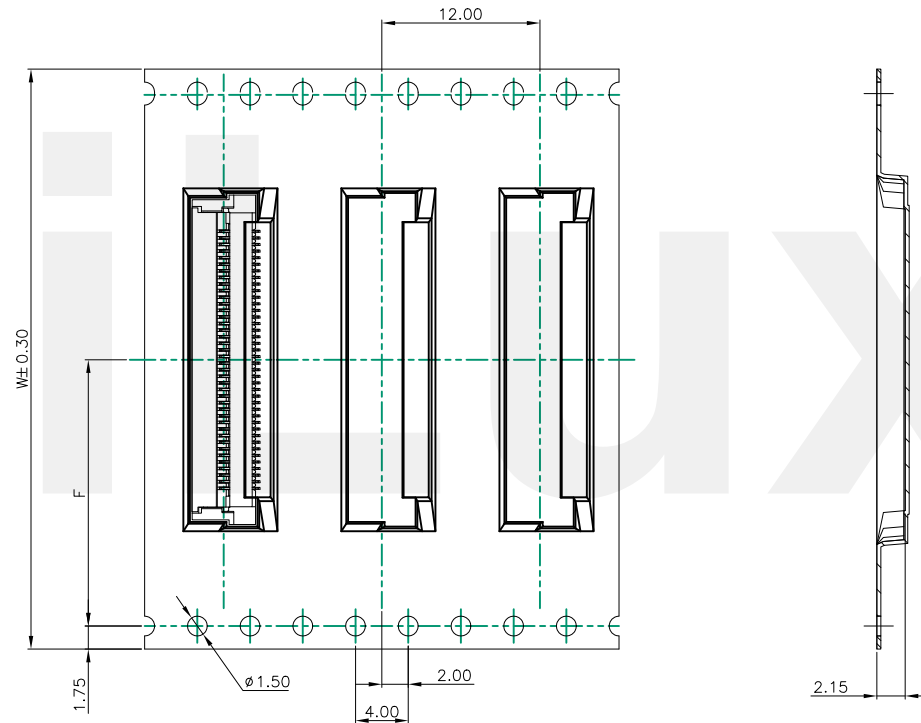
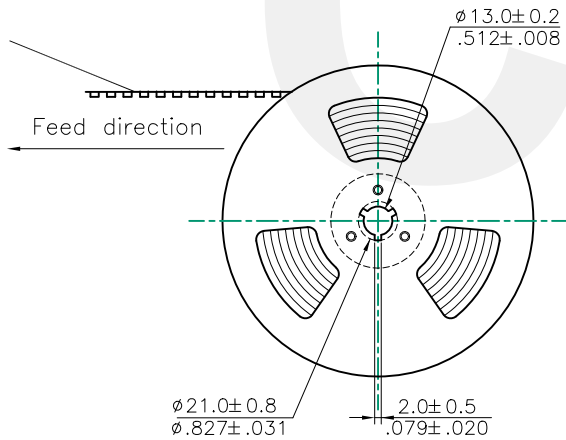
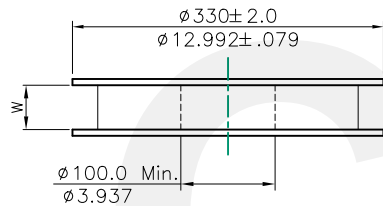

WIDTH : 44 mm Carrier

RoHS Compliant

SYM	NAME	DATE	REVISIONS	APPROVED BY:	DATE	UNIT: mm / inch	TITLE: 0.50mm(.020") ZIF FFC/FPC ONE-TOUCH CONNECTOR	瀚荃股份有限公司 CviLux Corporation		
4					DATE	UNIT: mm / inch	MATERIAL:	DRAWING NO. CF6901SA	PART NO. CF6940*D0*0-05-NH	SHEET 3 OF 3
3					DATE	TOLERANCE UNLESS OTHERWISE SPECIFIED				
2					DATE	.X \pm 0.25/.010	.X' \pm	SHEET 3 OF 3		
1	Clark	01/03-17	ECNT117002		DATE	.XX \pm 0.15/.006			.X' \pm 2'	SHEET 3 OF 3
					DATE	.XXX \pm	.X' \pm	SHEET 3 OF 3		

2017.02.03
ISSUED