

Halogen-Free Lead Free Process RoHS Compliant

4					DATE	UNIT: mm / inch	TITLE:	 瀚荃股份有限公司 CviLux Corporation
3					2/17-21'	TOLERANCE UNLESS OTHERWISE SPECIFIED	M.2 CONNECTOR KEY ID "B"	
2					2/18-21'	± 0.2 / .008 X: ± 3'	MATERIAL:	DRAWING NO. CS7601SB
1	Karen	2/17-21'	ECNT121038/ECRT120100	CHECKED BY:	2/19-21'		FINISH:	PART NO. CS76672AB0-R0
SYM	NAME	DATE	REVISIONS	APPROVED BY:	2/19-21'		SCALE	SHEET 1 OF 4

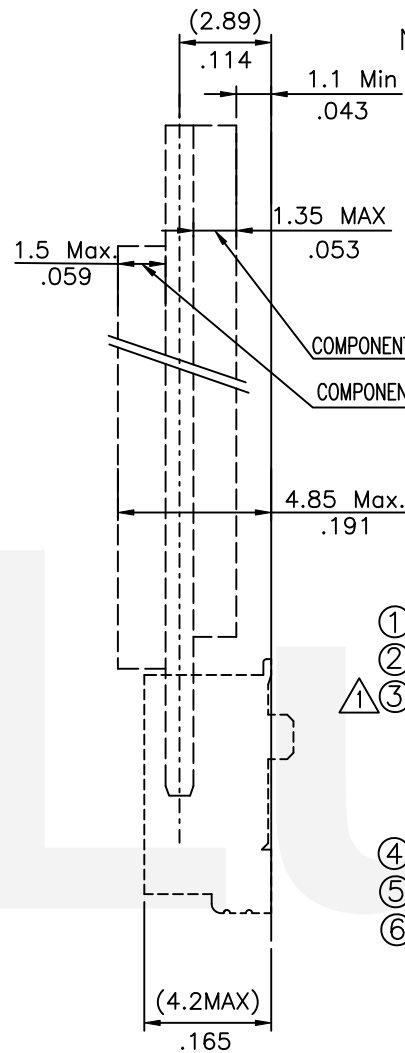

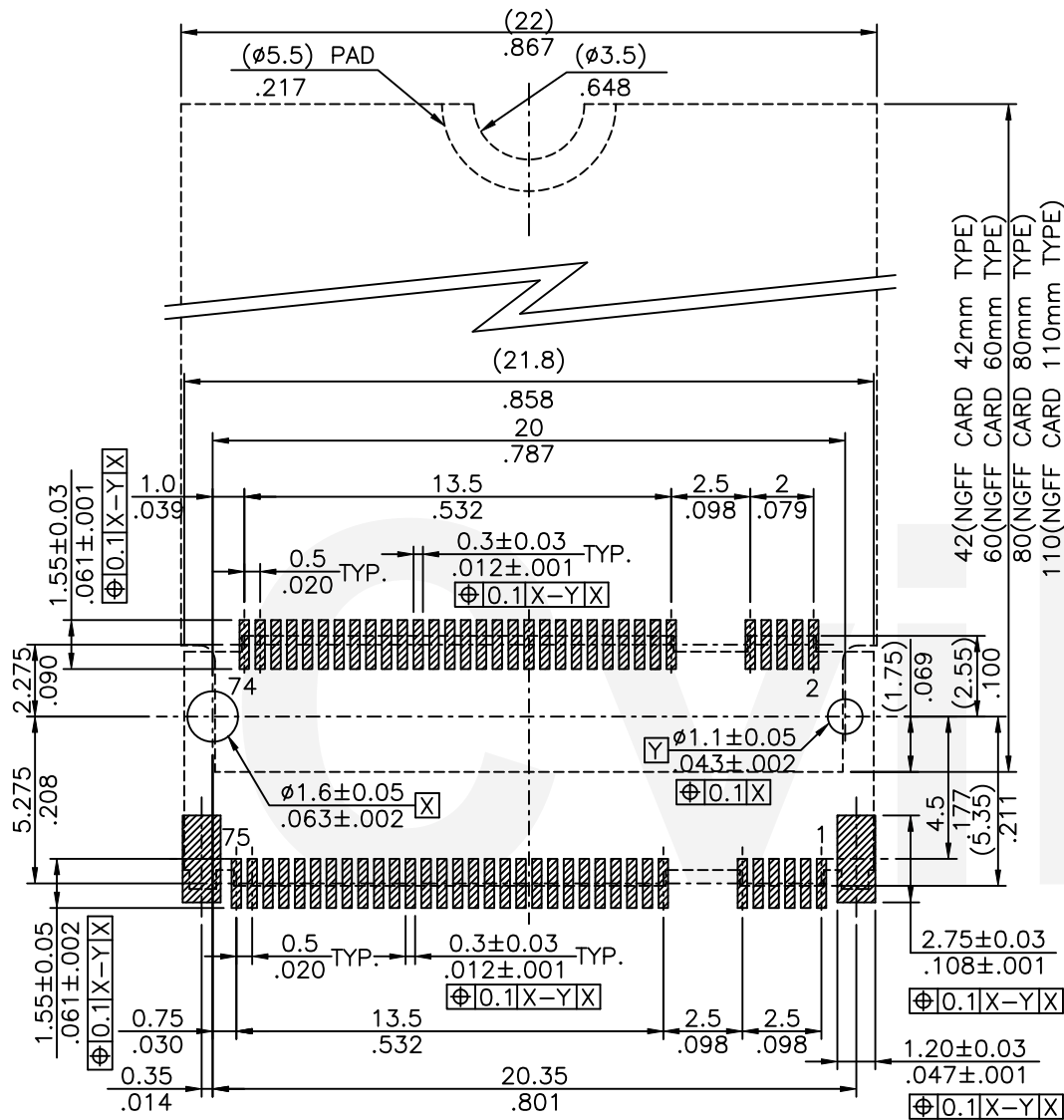

Note:
 Material:
 * Insulation: High Temperature Thermo Plastic UL 94V-0
 * Terminal: Copper alloy
 * Solder Peg : Copper alloy
 * For Lead-Free IR Reflow process

COMPONENT HEIGHT(BACK SIDE)
 COMPONENT HEIGHT(FRONT SIDE)

Ordering Code:

CS76 67 2 A B0 - R0
 ① ② ③ ④ ⑤ ⑥

- ① Series No.
- ② No. of Circuits:
- ③ Plating :

Plating Code	Plating			
	Contact area	Soldertail	The Other area	Under plating
2	0.008μm(0.3μ") Gold flash	0.008μm(0.3μ") Gold flash	1.52μm(60μ") Nickel	1.52μm(60μ") Nickel

- ④ Height : A=4.00mm
- ⑤ Key ID: B = Key B
- ⑥ Option: R0=Reel Packing

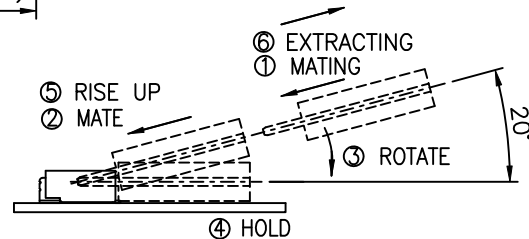

KEY ID "B"
 RECOMMENDED P.C.BOARD LAYOUT

Halogen-Free
 Lead Free Process
 RoHS Compliant

④				DATE	UNIT: mm / inch	TITLE:	瀚荃股份有限公司 CviLux Corporation
③					TOLERANCE UNLESS OTHERWISE SPECIFIED	M.2 CONNECTOR KEY ID "B"	
②				DRAWN BY: Karen 2/17-21'	± 0.2 / .008 X: ± 3'	MATERIAL:	
①	Karen	2/17-21'	ECNT121038/ECRT120100	ENGINEER: Sun 2/18-21'		FINISH:	
SYM	NAME	DATE	REVISIONS	CHECKED BY: Eisley 2/19-21'	APPROVED BY: Eisley 2/19-21'	DRAWING NO. CS7601SB	PART NO. CS76672AB0-R0
						SCALE 1 / 1	SHEET 2 OF 4



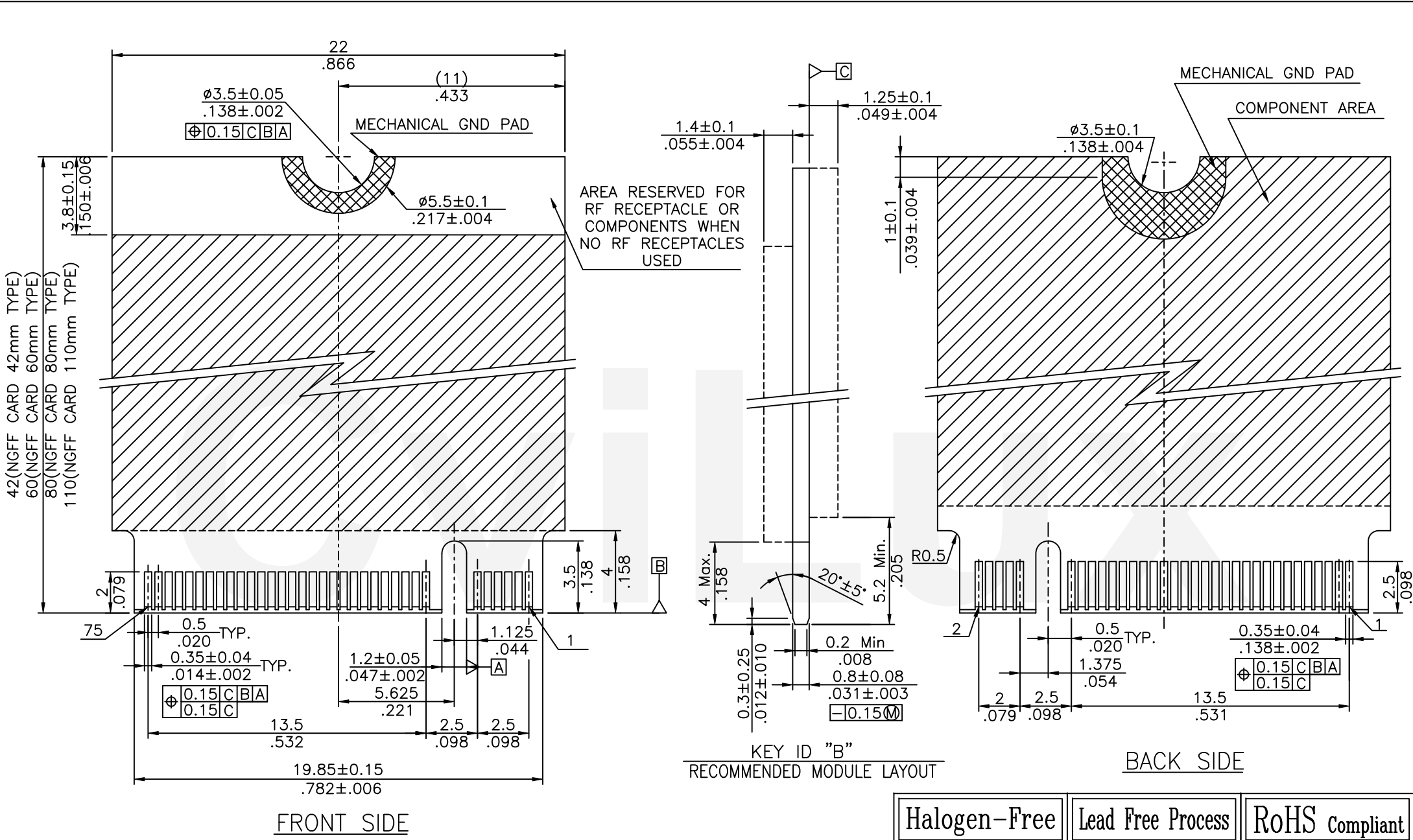

Halogen-Free Lead Free Process RoHS compliant

4					DATE	UNIT: mm / inch	TITLE:	瀚荃股份有限公司 CviLux Corporation
3				DRAWN BY: Karen	2/17-21'	TOLERANCE UNLESS OTHERWISE SPECIFIED	M.2 CONNECTOR KEY ID "B"	
2				ENGINEER: Sun	2/18-21'	± 0.2 / .008 X: ± 3'	MATERIAL:	
1	Karen	2/17-21'	ECNT121038/ECRT120100	CHECKED BY: Eisley	2/19-21'		FINISH:	
SYM	NAME	DATE	REVISIONS	APPROVED BY: Eisley	2/19-21'			DRAWING NO. CS7601SB
								PART NO. CS76672AB0-RO
								SCALE 1 / 1
								SHEET 3 OF 4

CVI LUX CORP
2021.02.25
ISSUED

NOTES:

- * Reel Material : Hips
- * Carrier Material : Black, Conductive Polystyrene Alloy
- * Cover Tape Material : Polyester
- * Cover Tape Peeling Angle : 165° to 180°
- * General Tolerance : ±0.5 , ±3°
- * Cover Tape Peel Strength : 10.0~130.0gf
- * Quantity : 1000 PCS/Reel

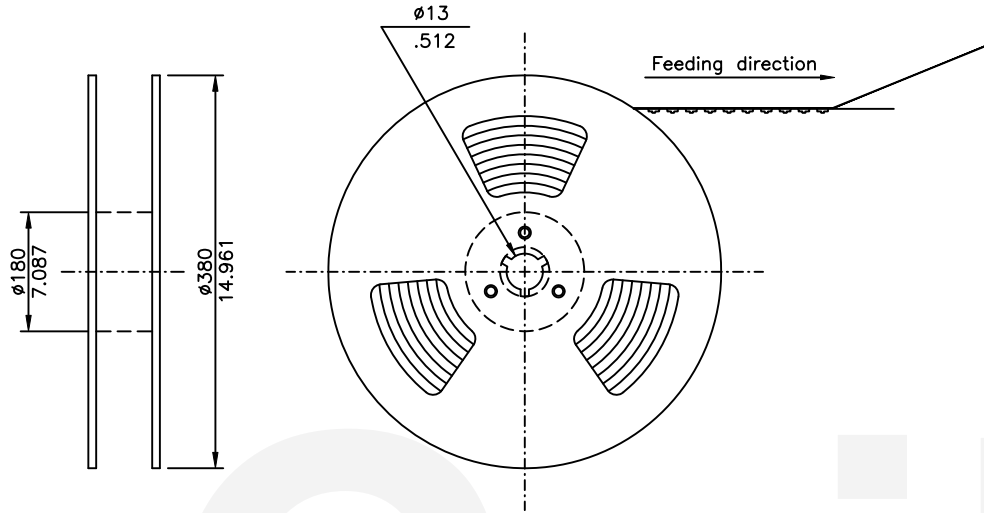

WINDING THE COVER TAPE
AROUND THE OUTER
PERIPHERY IN A TURN.

Peeling Angle
165° to 180°



Empty Packaging Portion Empty

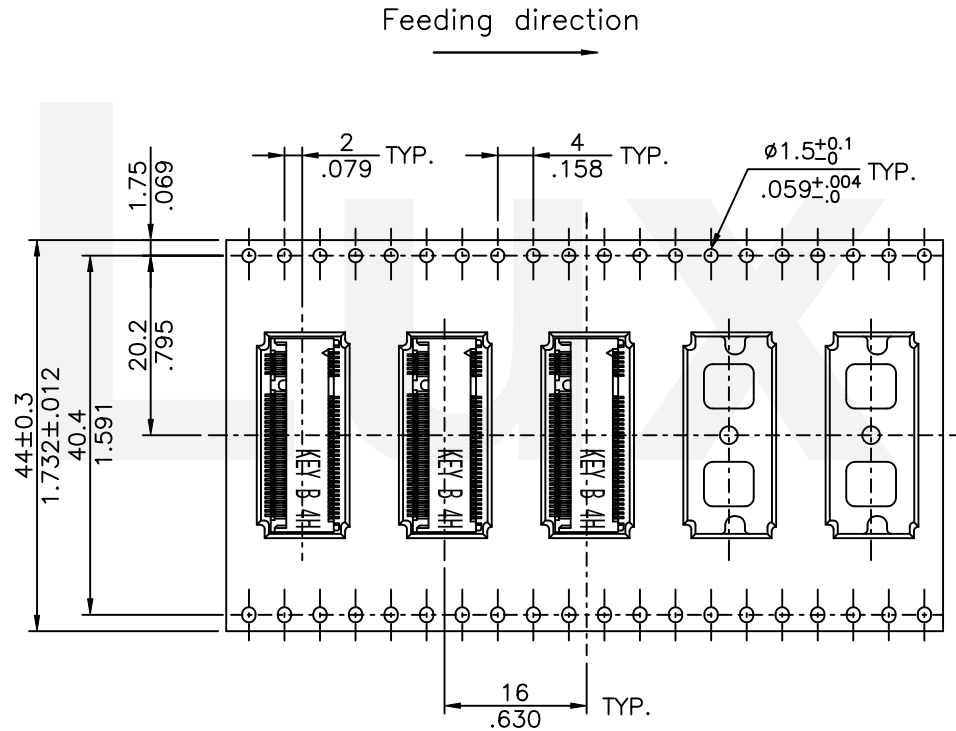

RoHS Compliant

4					DATE	UNIT: mm / inch	TITLE:	 瀚荃股份有限公司 CviLux Corporation
3					DRAWN BY: Karen	TOLERANCE UNLESS OTHERWISE SPECIFIED	M.2 CONNECTOR KEY ID "B"	
2					ENGINEER: Sun		MATERIAL:	DRAWING NO. CS7601SB
1	Karen	2/17-21'	ECNT121038/ECRT120100		CHECKED BY: Eisley		FINISH:	PART NO. CS76672AB0-RO
SYM	NAME	DATE	REVISIONS		APPROVED BY: Eisley			SCALE 1 / 1
								SHEET 4 OF 4

CIVILUX CORP
 2021.02.25
 ISSUED